



INTRODUCTION



EN(1-8) CONTENTS

01 Brand Introduction	(01)
02 Warm Note	(02)
03 Q & A	(02)
04 Product Introductions	(03)
05 Detailed Instruction of Functions	(03)
06 Product Installation	(05)
07 Wiring Methods	(06)
Installation method of round/ oval mirror	(07)
Installation method of rectangular mirror	(08)

DE(9-16) Katalog

01 Über	der Marke	(09)
02 Hinweis		(10)
03 Kundenfragen und -antworten		(10)
04 Produktbeschreibung		(11)
05 Einführung in die Spiegelfunktion		(11)
06 Installation		(13)
07 Verdrahtungsmethode		(14)
Installationsmethode für runde und ovale Badezimmerspiegel		(15)
Installationsmethode für quadratische Badezimmerspiegel		(16)

JP(17-24) 目次

01 ブランド紹介	(17)
02 注意事項	(18)
03 Q & A	(18)
04 製品紹介	(19)
05 鏡の使用法	(19)
06 取付工事手順	(21)
07 電流の接続方法	(22)
円形/楕円形の鏡の取付工事手順	(23)
スクエア形の鏡の取付工事手順	(24)

FR(25-32) TABLE

01 Instruction de la marque	(25)
02 Avis importants	(26)
03 Q & A	(26)
04 Instruction du produit	(27)
05 Les fonctions du miroir	(27)
06 Installation manuel	(29)
07 Méthode de câblage	(30)
Méthode d'installation de miroir de salle de bain rond et ovale	(31)
Méthode d'installation du miroir de salle de bain carré	(32)

ES(33-40) CONTENIDOS

01 Introducción de la marca	(33)
02 Consejos	(34)
03 Q & A	(34)
04 Descripción del Producto	(35)
05 Introducción a la función de espejo	(35)
06 Instalación del producto	(37)
07 Método de cableado	(38)
Guía para la instalación del espejo redondo y ovalado	(39)
Guía para la instalación del espejo cuadrado o rectangular	(40)

KR(41-48) 내용물

01 브랜드 소개	(41)
02 주의 사항	(42)
03 Q & A	(42)
04 제품 소개	(43)
05 기능 설명	(43)
06 제품 설치	(45)
07 배선 방법	(46)
원형/타원형 미러 설치 방법	(47)
사각거울 설치방법	(48)

ITA(49-56) CONTENUTI

01 Introduzione del marchio	(49)
02 Promemoria importante	(50)
03 Q & A	(50)
04 Introduzione del prodotto	(51)
05 Introduzione alle funzioni dello specchio	(51)
06 Installazione del prodotto	(53)
07 Metodo di cablaggio	(54)
Installazione di specchio da bagno rotondo/ovale	(55)
Metodo di installazione dello specchio da bagno rettangolare	(56)

Brand Introduction

LED Bathroom Mirrors, Make Life Polychrome

We strive to deliver real value for our customers through distinctive design, superb quality and excellent customer service at prices that reflect the real worth of our products.

*Anti-fogging/Dimmable Light/Memory Function/3 Year Warranty
Perfect choice for your bathroom, bedroom and makeup room.*



- ▶ We strictly implement quality control to ensure that the products are 100% safe and qualified. If there is any problem when you receive the mirror, please feel free to contact us by email.
- ▶ If you are satisfied with the mirror, welcome to share it on social media.
We look forward to your comments and video feedback as well as your suggestions for us.

Warm Note

- 1.If you have any confused questions about the mirror,you can e-mail us and we are willing to help you solve problem.
- 2.If you find the electronic component damaged,please contact us and we'll resend to you.



Wiring must be installed by qualified electricians

- ▶ If you have any suggestions or advice, please feel free to send e-mail to our customer services.

Q & A

After receiving the mirror, if you have any problem, please contact customer service at the first time. We will solve the problem for you within 48 hours and you have the chance to win a small prize

Q1: What if the mirror broken after you receive the package?

A: Please don't worry about it. Take a photo and contact our customer service, we will handle it within 48 hours for you.

Q4: If the inner light strap of the bathroom mirror comes off?

A: Please don't worry about it, please contact our customer service, we will quickly help you to solve such problems.

Q2: The defog function does not work, how to do?

- A: 1. Check whether the switch is turn on (white means turn on)
 2.The defog function need to be turned on after 5 minutes to work, please be patient.
 3. If it still can't work, please contact our customer service.

Q5: The bathroom mirror doesn't work after wiring, how to do?

A: Please make sure the null line of wire connection is correct.

Q6: Bathroom cracks on the back of the mirror, what can you do?

A: Please contact our customer service, we will send a waterproof repair subsidy to you.

Q3: The bathroom mirror button does not work?



- A: 1. Open the bathroom mirror back cover, check whether the switch is shifted, if switch shift, just restore the position.
 2. If it's a bad connection, please rewiring.

Q7: How to daily maintenance of the bathroom mirror?

A: You can use the dust cloth and wipe it with warm water.

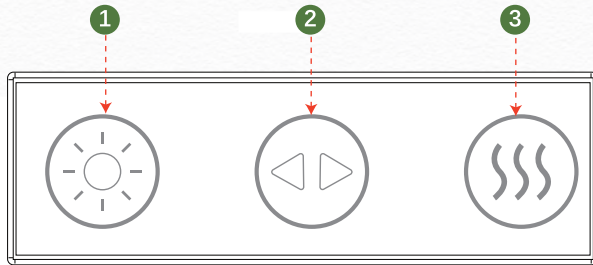
Product Introduction



- 1  On/Off Switch - Short press the button for On/Off / long press to adjust brightness
- 2  Light Switch Button: Press the middle button to adjust to different lighting, white light/ neutral light/ warm light.
- 3  Anti-fog Button - Press the button for anti-fog function

Detailed Instruction of Functions

Description of Heated Auto-defog Functions



Short press the button for On/Off the light
Long press to adjust light brightness

* For the on-off key, white for on state,
yellow for off state

Light Change Button -adjust different lights



Short press the button to adjust from white/ warm white/ warm lighting color

* You need to turn the on-off key on to switch the color temperature

Description of Heated Auto-defog Functions



Touch to open mirror defogging function

Mirror defogging constant temperature: 38 °C-45 °C

*The defogging function can also be used without turning on the light

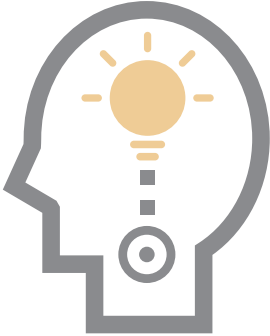
Memory Function

* The mirror features memory function, the next time you turn the light on, the lighting color will be the same as the last one.

Product Installation

06

Recommend Height

1. When installing the bathroom mirror, please first pick up the bathroom mirror and confirm the best installation height for marking, then punch for installation
2. Make sure your face is in the middle of the mirror for a better image.

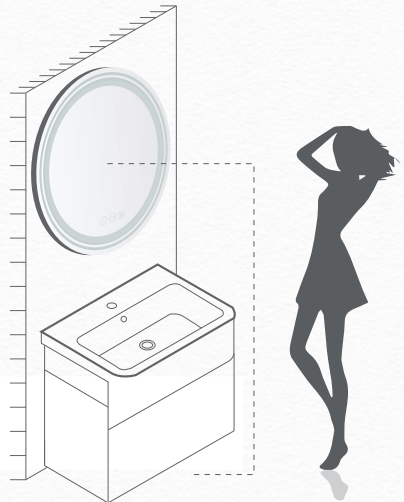

Wiring Method

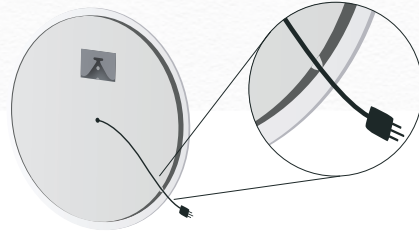
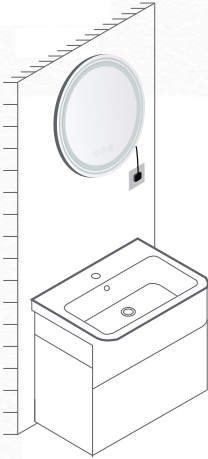

Method 1

Extend the line of the bathroom mirror from the grooves on the side and plug it in to use.

To reduce the risk of strangulation, the flexible cable connected to this luminaire must be fixed on the wall when the cable is in the hand region

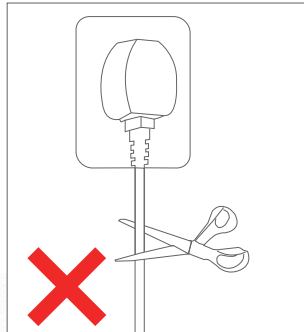
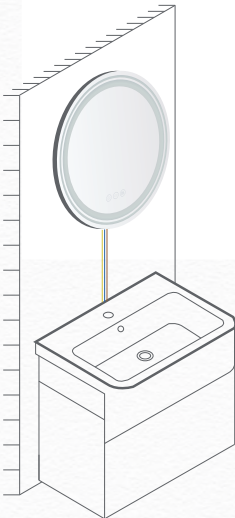

Method 2

1. Wiring must be installed by qualified electricians
2. Please use insulating tape to protect the wires

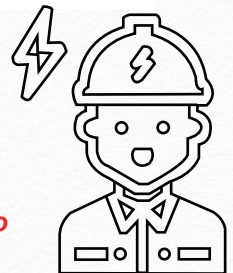

	AU	US	EU	UK	TP	JP
L					Don't need to distinguish the wiring colors	
N						
E						

Round /Oval Bathroom Mirror Installation



Tape Measure



Pencil



Drill



Hammer



Screwdriver



Screw Kit (Set)

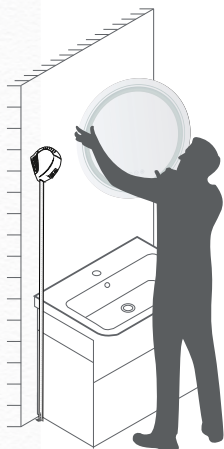

1. Measure the best installation height with a tape measure

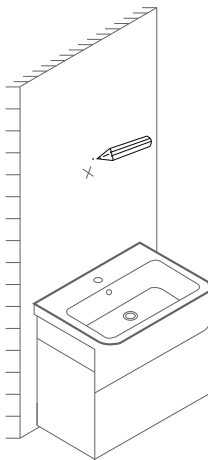

2. Mark the wall with a pencil

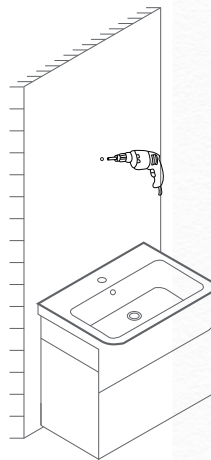

3. Drill the marks with an electric drill.

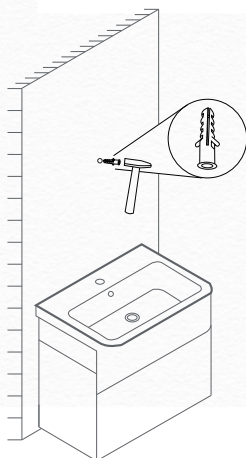

4. Drive the expansion rubber plug into the hole.

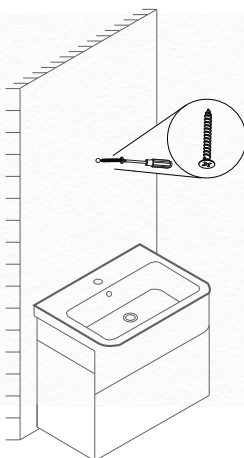

5. Drive a screw into the hole.

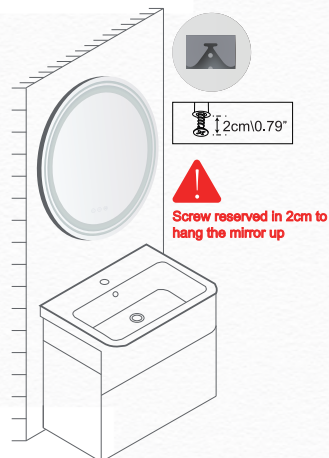

6. Hang up the bathroom mirror.

Square Bathroom Mirror(Vertically/Horizontally)



Tape Measure



Pencil



Drill



Hammer



Screwdriver



Screw Kit (Set)

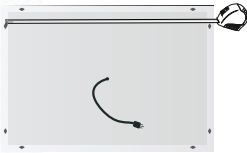

1. Measure the distance of the bathroom mirror hook.

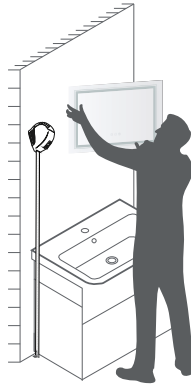

2. Lift the bathroom mirror up to confirm the best mounting height

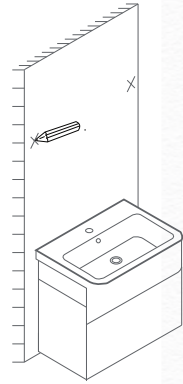

3. Mark the wall with a pencil

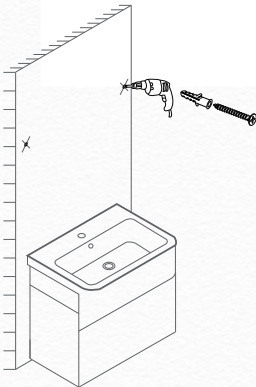

4. Drill the marks with an electric drill. Drive a screw and an expansion plug into the hole.

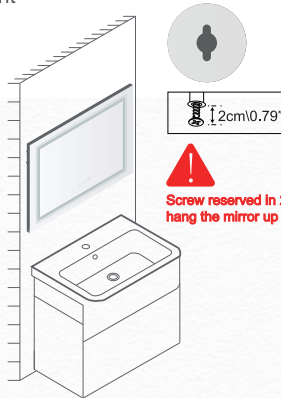

Screw reserved in 2cm to hang the mirror up

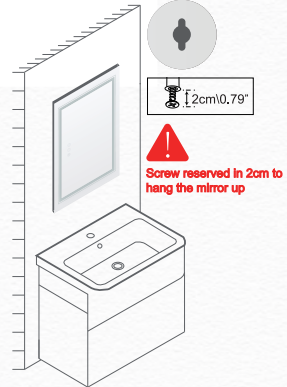

Screw reserved in 2cm to hang the mirror up

5. Hang up the bathroom mirror.

You can hang it vertically in the same way

Über der Marke

LED Badezimmerspiegel, macht das Leben bunt und schön!
Wir streben danach, unseren Kunden durch unverwechselbares Design einen echten Mehrwert zu bieten.
Hochwertige Qualität und exzellenter Kundenservice zu Preisen, die die Realität widerspiegeln Wert unserer Produkte.
Antibeslag/Dimmbar/Speicherfunktion/3 Jahre Garantie
Perfekte Wahl für Ihr Badezimmer, Schlafzimmer und Schminkzimmer.



- ▶ Wir führen strenge Qualitätskontrollen durch, um sicherzustellen, dass die Produkte 100% sicher und qualifiziert sind.
 Wenn Sie den Spiegel erhalten haben, gibt es etwas Problem, Sie können bitte uns gerne per E-Mail kontaktieren.
- ▶ Wenn Sie mit dem Spiegel zufrieden sind, können Sie bitte ihn gerne in den sozialen Medien teilen.
 Wir freuen uns auf Ihre Kommentare, Video-Feedback oder guten Vorschlag für uns.

Warmer Hinweis

1. Nachdem Sie die Antibeschlag-funktion verwendet haben, schalten Sie die Antibeschlag-funktion rechtzeitig aus, um eine Beschädigung des Antibeschlagsfolies zu vermeiden;
2. Beschädigte LED-leiste und Antibeschlagfolie können ersetzt werden



Die Verkabelung muss von einem professionellen und qualifizierten Elektriker durchgeführt werden.

- Wenn Sie bessere Vorschläge für das Produkt haben, können Sie den Kundendienst per E-Mail kontaktieren

Q & A

Wenn das Produkt irgenwelche Problemen haben, bitte kontaktieren Sie unseres Kundenserviceteam, wir werden Ihnen eine perfekte Lösung in 48 Stunden geben.

Q1:kam der Spiegel beschädigt?

A:Keine Sorge mehr, bitte senden Sie uns ein defekte Bild, wir werden das Problem in 48 Stunden lösen.

Q2:Funktioniert das Antibeschlaggerät nicht?

- A: 1.Checken Sie mal, ob der Antibeschlagschalter öffnen ist.(Weiß = ON)
 2.Nach Sie die Antibeschlageschalter öffnen, bitte erwarten Sie etwa 5 Minuten für die gute Wirkung.
 3.Wenn das funktioniert noch nicht, bitte kontaktieren Sie unseres Kundenserviceteam.

Q3:Funktioniert die Schalter nicht?

- A: 1.Bitte öffnen Sie das Rückbrett, checken Sie mal, ob das Schaltergeräte verlagert ist, wenn ja, bitte legen Sie das zurück.
 2.Die Kabel des Schalters funktioniert nicht, bitte verbinden Sie die wieder mal.

Q4:Fallen LED-Streifen ab?

A:Bitte machen Sie keine Sorge und kontaktieren Sie unseres Kundenserviceteam, wir werden das Problem lösen.

Q5:Funktioniert der Badezimmerspiegel nach Installation der Verkabelung nicht mehr?

A:Bitte überprüfen Sie, ob der Neutralleiter und der stromführende Draht richtig angeschlossen sind.

Q6:Hat die Rückplatte Risse?

A:Bitte kontaktieren Sie das Serviceteam, wir werden Ihnen ein Wasserdicht Kleber nachsenden.

Q7:Wie man einen Badezimmerspiegel täglich pflegt?



A:Verwenden Sie zum Abwischen ein sauberes, in Wasser getauchtes Tuch.

Die Installation, Wartung und Reparatur von Badezimmerspiegeln ist sehr einfach und alle sind mit Anleitungsvideos ausgestattet.

Wenden Sie sich bei Bedarf bitte an den Kundenservice.

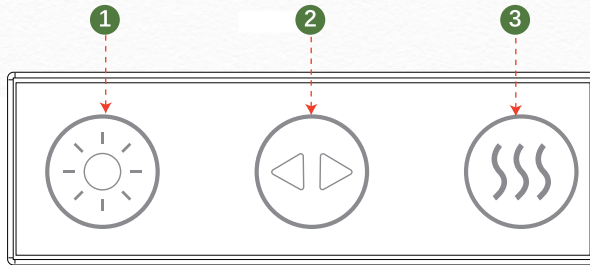
Produktbeschreibung



- 1  An/Ausschalter - kurz Drucken, um das Licht an/auszumachen / lang Drucken, um die Helligkeit des Lichtes zu dimmen
- 2  Lichtschaltertaste: Drücken Sie die mittlere Taste, um verschiedene Lichter auszuwählen: weißes Licht, neutrales Licht, warmes Licht.
- 3  Anti-Beschlag-Schalter

Über Multifunktionen

An/Ausschalter- an/aus und dimmbar



kurz Drucken, um das Licht an/auszumachen
Lang Drucken, um die Helligkeit des
Lichtes zu dimmen

* Der Schalter ist weiß für den eingeschalteten
Zustand und gelb für den ausgeschalteten
Zustand

Farbwechsel-Schalter



Kurz Drucken, um die Lichtfarbe zu wechseln
Kaltweiß/Neutral/Warmweiß

* Der Schalter muss eingeschaltet werden,
um das Spiegellicht einzustellen

Anti Beschlage



Leicht Toch zur Anti-Beschlag-Funktion

Konstante Temperatur der Spiegelehtnebelung: 38°C -45°C

*Die Antibeschlagfunktion kann allein verwendet werden,
die Funktion kann bei Nichtgebrauch ausgeschaltet werden

Memory Funktion



* Nachdem Sie auf die entsprechende Helligkeit eingestellt haben, sie ausschalten und dann wieder einschalten, ist die Helligkeit immer noch gleich

Produckinstallation

06

Die beste Höhe

1. Wenn Sie diesem Badspiegel installieren, bitte bestätigen Sie die beste Installationshöhe und markieren Sie es, dann bohren Sie bitte ein Loch.
2. Wir schlagen den beste Blickwinkel vor, dass das Gesicht in der Mitte des Spiegels sein lass. (Sehen Sie bitte das rechts Bild)

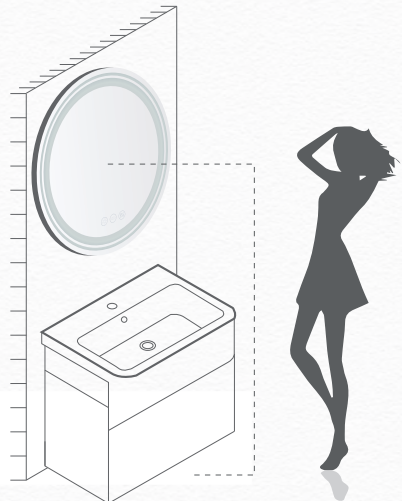

Verdrahtungsmethode

07

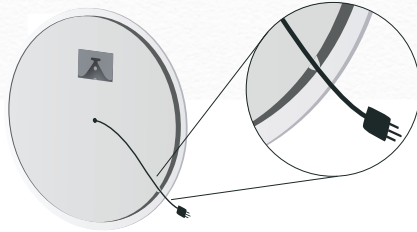
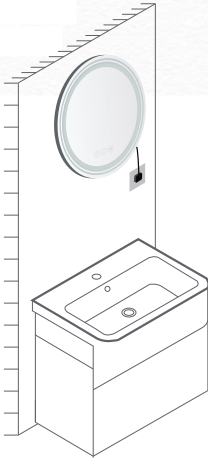

Methode 1

Ziehen Sie das Kabel aus dem seitlichen heraus und stecken Sie den Stecker ein.

Zur Reduzierung des Strangulationsrisikos muss das flexible Kabel der Leuchte im Handbereich fest an der Wand fixiert werden.

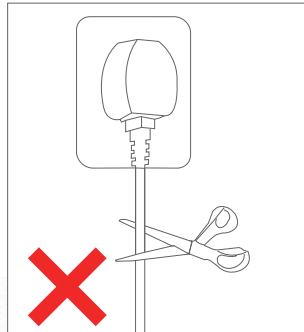
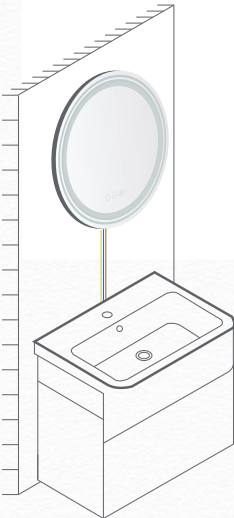

Methode 2

**1. Die Verkabelung muss von einem professionellen und qualifizierten Elektriker durchgeführt werden.
2. Verwenden Sie Isolierband, um die Leitungen zu schützen.**

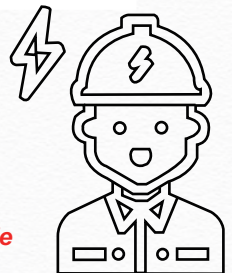

	AU	US	EU	UK	TP	JP
L					Don't need to distinguish the wiring colors	
N						
E						

Die Installationsmethode des runden und oval Badspiegel



Maßband



Bleistift

Elektrische
Bohrmaschine

Hammer



Schraubendreher



Schrauben-Set

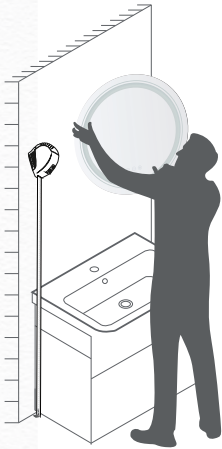

1. Verwenden Sie ein Maßband, um die beste Installationshöhe zu messen.

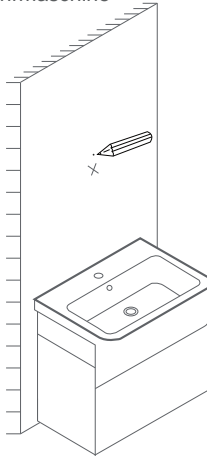

2. Markieren Sie die Wand mit einem Bleistift.

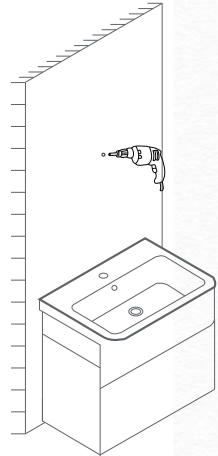

3. Verwenden Sie eine elektrische Bohrmaschine, um Löcher an den markierten Stellen zu machen.

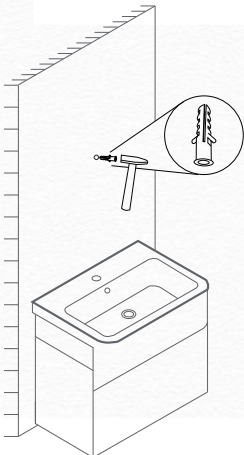

4. Installieren Sie bitte den Dübel

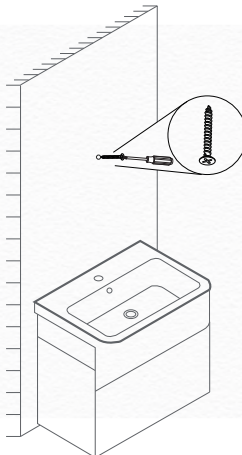

5. Bohren Sie bitte die Schraube

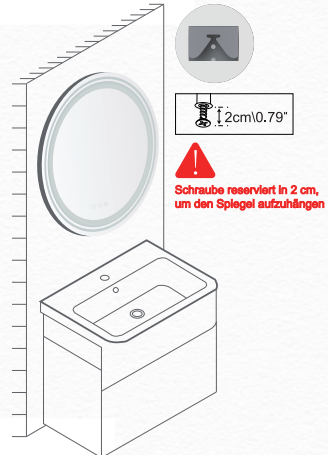

6. Hängen Sie bitte mit dem Haken auf

 Schraube reserviert in 2 cm, um den Spiegel aufzuhängen

Die Installationsmethode des rechteckigen Badspiegels (Kann vertikal installiert werden)



Maßband



Bleistift

Elektrische
Bohrmaschine

Hammer



Schraubendreher



Schrauben-Set

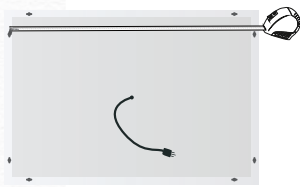

1. Verwenden Sie ein Maßband, um die Breite des Badspiegels zu messen.

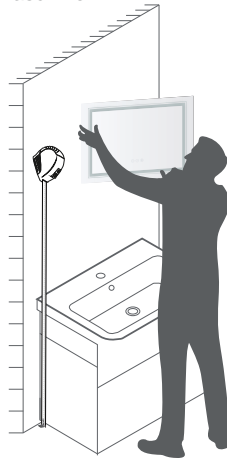

2. Messen Sie bitte die beste Installationshöhe.

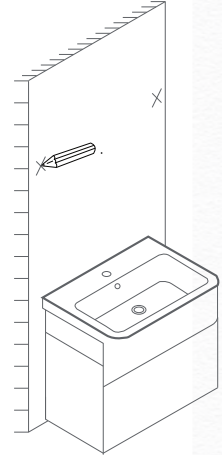

3. Markieren Sie die Wand mit einem Bleistift.

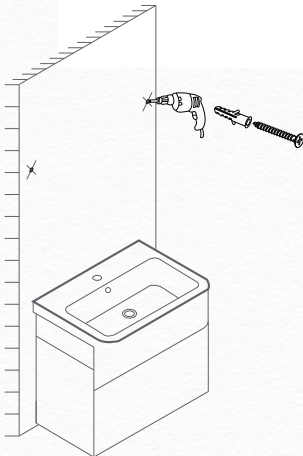

4. Lochen Sie bitte den Dübel und Schraube

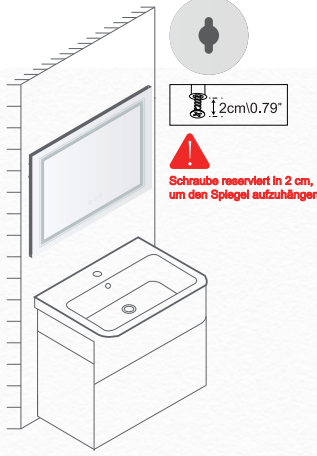

5. Hängen Sie bitte den Badspiegel auf

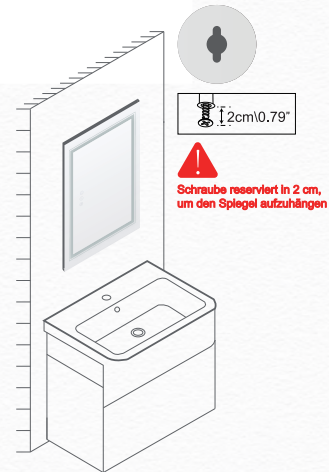

Installieren Sie bitte auf die gleiche Methode, dann kann vertikal installiert werden.

ブランド紹介

のモットーは、安くても高品質な商品を提供することです。

が提供している高品質のバスルームミラーは、顧客の理想のライフスタイルを応援します。

顧客満足度を上げるために、曇り止め/調光/調色/メモリー機能を全部備えたバスルームミラーを設計しました。お客様に安心してご購入頂けるよう、本製品をご購入後、一年間の品質保証があります。



- ▶ 当社は、お客様に安心、安全な製品を提供するよう、製品安全の確保に努めてまいります。商品の品質や包装には細心の注意を払っておりますが、万が一不備がございましたら、大変お手数ではございますが、当店までご連絡をお願いいたします。
- ▶ 自社の製品やサービスの向上や発展のため、お客様の貴重な意見やフィードバックを歓迎いたします。

02

| 注意事項

- 1、本製品の使用上に何かご質問がありましたら、お気軽に出品者にご連絡ください。
- 2、本製品の全ての部品（モジュール、LEDテープライトなど）も簡単に交換できますので、万が一壊れた部品がありましたら、代わりに部品を発送することが可能なので、当店までご連絡をお願いいたします。



配線は資格のある専門の電気工事士によって取り付けられる必要があります。

- ▶ 自社の製品やサービスの向上や発展のため、お客様の貴重な意見やフィードバックを歓迎いたします。

| Q & A

03

保証: 万が一、不具合な商品を届けた場合なら、返品が要らずに無償で再送することが対応しておりますので、お気軽に直接に弊社にご連絡ください。

Q1: 届いた鏡が破損してしまった場合なら、どうすればいいですか

A: 万が一、不具合な商品を届けた場合なら、返品が要らずに無償で再送することが対応しておりますので、お気軽に直接に弊社にご連絡ください。

Q2: 結露取り機能が効かない場合なら、どうすればいいですか

- A: 1、まず、結露取り機能がついているかと確認してください。（タッチボタンが白く光っている: ONです）
2、結露取り機能をつけた後、5分間ぐらいお待ちください。
3、5分間を経た後も鏡面が温かくなならない場合には、弊社にご連絡ください。

Q3: タッチボタンが効かない場合なら、どうすればいいですか

- A: 1、まず、鏡の背板を開けて、モジュールがズレているかとチェックしてください。
2、次、コードの接続具合をチェックしてください。

Q4: 鏡のLEDテープライトは剥がれてしまった場合なら、どうすればいいですか

A: お気軽に直接に弊社にご連絡ください。

Q5: 鏡は別途のスイッチに接続した後、点灯などが出来ない場合なら、どうすればいいですか

A: N電線とL電線は逆に接続しているかとチェックしてください。

Q6: 鏡の背板は裂けてしまった場合なら、どうすればいいですか

A: お気軽に直接に弊社にご連絡ください。無償で修理用のテープをご発送いたします

Q7: 鏡のメンテナンスについて、



A: 濡れたタオルなどほこりや汚れなど拭い去ってください。

鏡の取付、メンテナンス、修理などもしやすく、説明ビデオもありますので、説明ビデオが必要な場合には、出品者にご連絡ください。

製品紹介

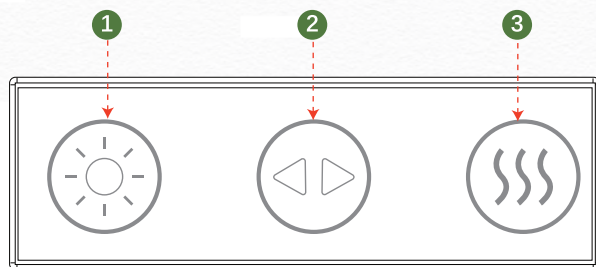
04



- 1  点灯スイッチ：タッチして点灯/長押しで明るさ調整
- 2  色温度ボタン：ワンタッチで昼光色・昼白色・電球色が切り替えられます。
- 3  曇り止めスイッチ：タッチして曇り止め機能を開始する

鏡の使用方法

05

点灯/明るさ調整スイッチ



点灯スイッチをワンタッチして点灯します
長押しして光の明るさを調節します

*左のボタンは白く光ったら、「ON」という意味で、黄色く光ったら、「OFF」という意味です

調光スイッチ



タッチして白色/昼光色/電球色の3つの照明色が選べます

*左のボタンを押すことで鏡のライトをつけた後、真ん中のボタンで色温度を切り替えることができます

結露取りボタンの説明



結露取りボタンをタッチしたら、鏡面が温かくなり、結露を取ることができます

恒温:38°C-45°C

*結露取り機能は単独につけたり消したりできます

メモリー(記憶)機能の説明



* お好みにより、LEDライトをある色や明るさに調整した後、次回にもその色や明るさに光ります。改めて設定する手間が省けますので、おしゃれて使い勝手のいい洗面台鏡です

06

取付工事手順

最適な高さ

1. 鏡が破損しないよう、鏡の取り付け作業は2人で行ってください。
2. 設置完了後は、ミラーのガタつきやゆるみがないことを必ず確認してください。



電流の接続方法

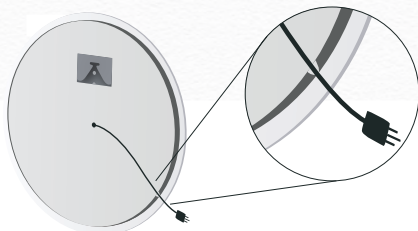
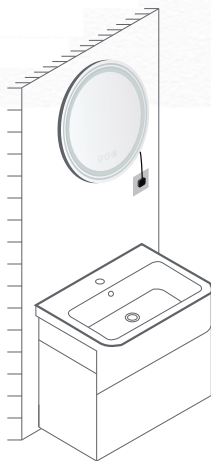

接続方法-1

電源コードの先端に付いているプラグを壁に取り付けられて
いるコンセントに挿し込みます。
(鏡の背面の縁には「欠け」があり、配線にご利用ください)

絞扼のリスクがあるため、この器具に接続されたフレキシブルケ
ーブルは、手の届く範囲にあるときに壁にしっかりと固定される必
要があります。

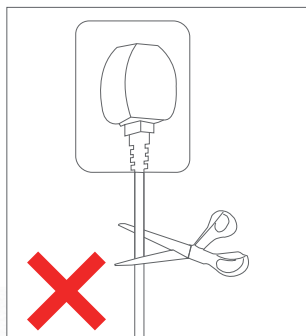
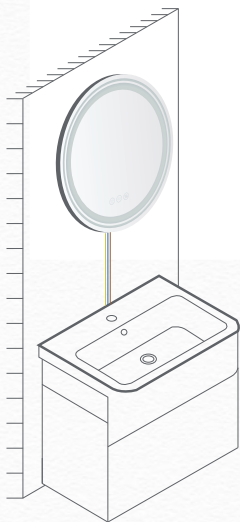

接続方法-2

1. 配線は資格のある専門の電気工事士によっ
て取り付けられる必要があります。

2. ワイヤーを保護するために絶縁テープを使
用してください。



	AU	US	EU	UK	TP	JP
L					Don't need to distinguish the wiring colors	
N						
E						×

円形／楕円形の鏡の取り付け工事手順



巻尺



鉛筆



電動ドリル



ハンマー



ドライバー



ネジセット



1.壁面の希望の高さに、取付位置を決めます

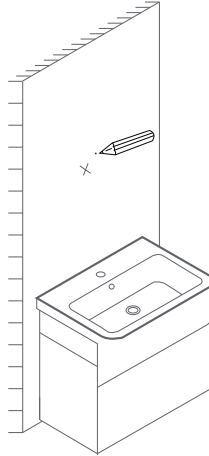

2.鉛筆でネジ穴の位置をマーキングします

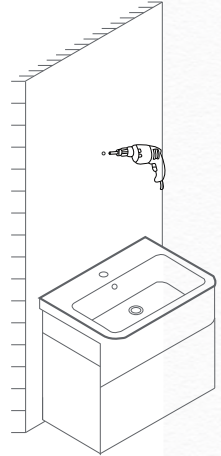

3.電動ドリルを使って、下穴を開けます

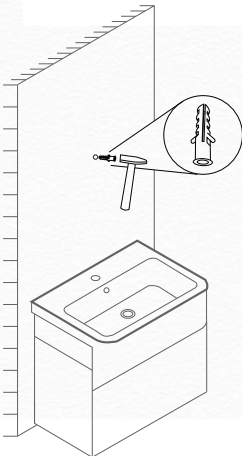

4.ハンマーでアンカーを壁面に打ち込みます

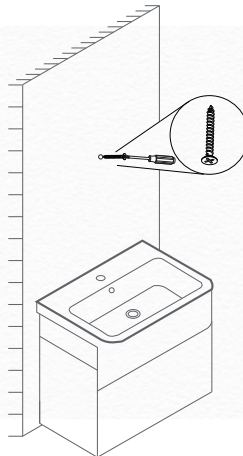

5.ネジをアンカーにねじ込みます



6.鏡を引っ掛けて設置完了です

長方形の鏡の取り付け工事手順 (縦・横どちらの向きでもOK)



巻尺



鉛筆



電動ドリル



ハンマー



ドライバー



ネジセット

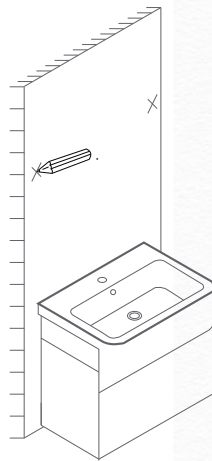
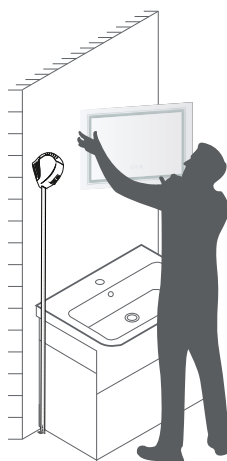
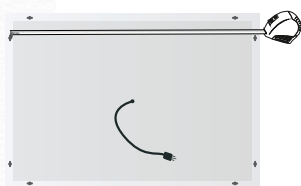

1. メジャーで鏡の背面の取付用フックの間隔を測定します

2. 壁面の希望の高さに、取付位置を決めます

3. 鉛筆でネジ穴の位置をマーキングします

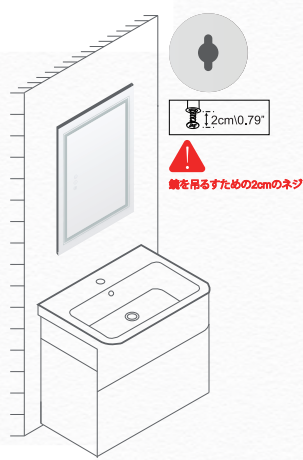
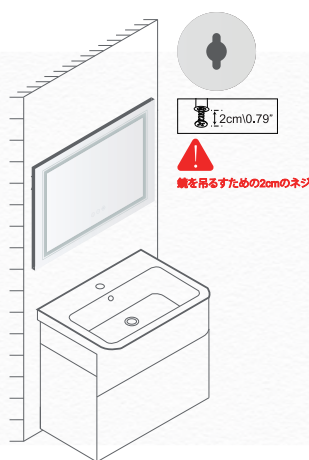
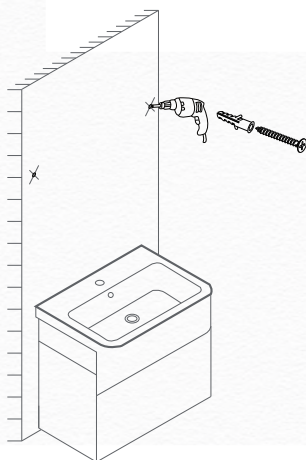

4. 電動ドリルで下穴を開けます。穴を開けた箇所にアンカーを挿してネジを締めます

5. 鏡を引っ掛けて設置完了です

6. 同じ手順で縦向きでも設置できます

À propos de notre marque

Nous nous efforçons d'offrir une valeur réelle à nos clients à un design distinctif, une superbe qualité et un excellent service client à des prix qui reflètent la valeur réelle de nos produits

Afin d'augmenter la satisfaction de nos clients, nous avons conçu les miroirs de salle de bain avec des fonctions anti-buée / gradation / mémoire. Il existe une garantie de qualité d'un an après l'achat afin que les clients puissent acheter en toute confiance



- ▶ Nous nous efforcerons d'assurer la qualité afin de fournir à nos clients des produits sûrs et sécurisés. Si vous trouvez des défauts, n'hésitez pas à nous contacter. Nous nous excusons pour la gêne occasionnée.
- ▶ Nous apprécions vos précieux conseils pour améliorer et développer nos produits et services.

Avis importants

1. Veuillez contacter notre service client pour toute question ou préoccupation et nous serons heureux de vous aider
2. Si une pièce semble manquante ou endommagée, ne vous inquiétez pas, veuillez contacter notre service client, le remplacement est très simple.



Le câblage doit être installé par un électricien professionnel et qualifié.

- Si vous avez des conseils du produit, veuillez nous les envoyer par email.

Q & A

En cas de problème avec le miroir, veuillez ne pas le retourner directement. Veuillez contacter notre service client dès que possible, nous résoudrons le problème pour vous dans 24 heures.

Q1: Que dois-je faire si le miroir que j'ai reçu est endommagé?

R: Prenez une photo et contactez notre service client, nous le résoudrons dans 24 heures.

Q2: Que dois-je faire si la fonction de désembuage ne fonctionne pas?

1. Assurez-vous que l'interrupteur de désembuage est activé (le bouton tactile s'allume en blanc).
2. Veuillez attendre environ 5 minutes après avoir activé la fonction de désembuage.
3. La fonction de désembuage ne fonctionne toujours pas, veuillez contacter notre

Q3: Que dois-je faire si le bouton tactile ne fonctionne pas?

1. Ouvrez le panneau arrière du miroir et vérifiez si l'interrupteur est déplacé.
2. Il y a des faux contacts à l'interrupteur, veuillez le recâbler.

Q4: Que dois-je faire si la bande lumineuse intérieure tombe ?

R: Veuillez contacter notre service client

Q5: Le miroir installé par câblage ne fonctionne pas, que dois-je faire?

R: Vérifiez si les fils neutre et sous tension sont connectés à l'envers.

Q6: Que dois-je faire s'il y a des fissures sur le panneau arrière?

R: Veuillez contacter notre service client, nous vous enverrons le ruban de réparation.



Q7: Comment entretenir le miroir au quotidien?

R: Vous pouvez le nettoyer avec un chiffon doux humide.

L'installation, l'entretien, la réparation sont faciles, nous avons des vidéos d'instructions. Si nécessaire, veuillez nous contacter.

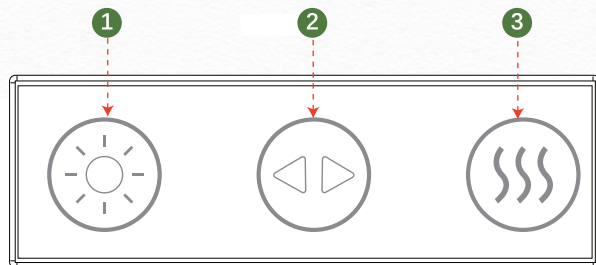
Instruction du produit



- 1  Interrupteur - Appuyez légèrement sur l'interrupteur du miroir / Appuyez et maintenez l'interrupteur pour régler la luminosité de la lumière
- 2  Interrupteur de lumière : appuyez sur le bouton du milieu pour sélectionner différentes lumières : lumière blanche, lumière blanche chaude, lumière chaude.
- 3  Touche de fonction de désembuage pour activer la fonction de désembuage du rétroviseur

Introduction des interrupteurs sur le miroir

Bouton d'alimentation - Fonction d'allumage et de réglage de la luminosité



Appuyez pour allumer la lumière du miroir de la salle de bain
Appuyez et maintenez le bouton de l'interrupteur pour régler la luminosité de la bande lumineuse

* la touche tactiles s'affichent en blanc,
la lumière est allumée
En jaune, la lumière est éteint

Interrupteur d'éclairage - Fonction de réglage du couleur de la lumière du miroir



Appuyez brièvement sur le bouton d'éclairage pour allumer la lumière du miroir
Lumière blanche/lumière blanche chaude/lumière chaude

* Vous devez allumer l'interrupteur, et puis régler la lumière du miroir

La fonction de désembuage



Température constante de désembuage du miroir: 38 °C -45 °C

* La fonction de désembuage peut être activée ou désactivée indépendamment

La fonction de mémoire



* Si vous le souhaitez, vous pouvez régler la lumière LED sur une certaine couleur et luminosité, la fonction de mémoire peut enregistrer la luminosité d'éclairage réglée la prochaine fois.

Installation du produit

06

Hauteur optimale

1. Lors de l'installation du miroir, veuillez d'abord le soulever (Le produit est lourd, plus de personnes sont nécessaires pour le soulever), confirmez la meilleure hauteur d'installation à marquer et perforez les trous
2. Essayez de garder le visage au milieu du miroir, afin que l'effet d'imagerie soit meilleur (voir l'image à droite)



Méthode de connexion d'alimentation électrique

07

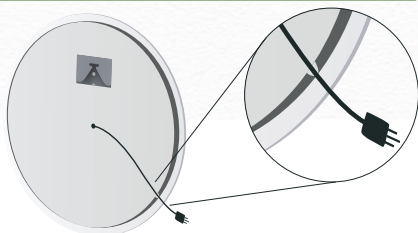
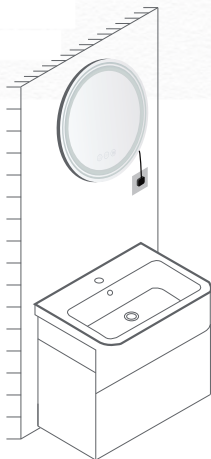

Méthode 1

Sortir le câble à travers du goulet derrière le miroir et connecter la prise

Pour réduire le risque d'étranglement, lorsque le câble est situé dans la zone des mains, le câble flexible connecté à ce luminaire doit être solidement fixé au mur.

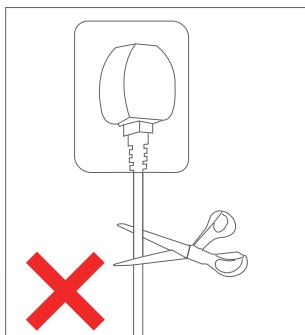
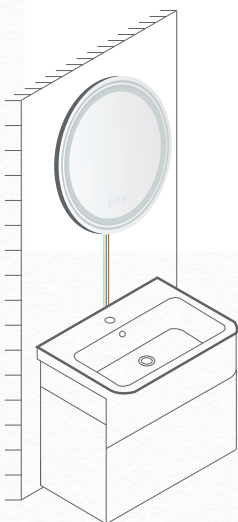

Méthode 2

1. Le câblage doit être installé par un électricien professionnel et qualifié.
2. Veuillez utiliser du ruban isolant pour protéger les fils.

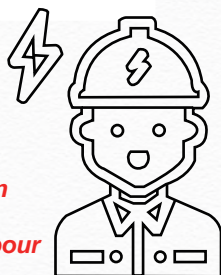

	AU	US	EU	UK	TP	JP
L					Don't need to distinguish the wiring colors	
N						
E						
					✗	

Méthode d'installation du miroir de salle de bain rond (la même méthode pour modèle ovale)



Bande d'Acier



Crayon



Perceuse électrique



Manteau



Tournevis



Sacnet de Vis

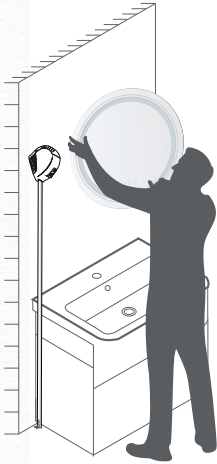

1. Soulever le miroir et mesurer la hauteur préférée

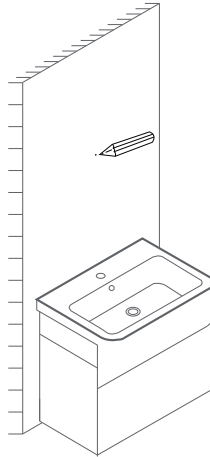

2. Marquer sur le mur avec le crayon

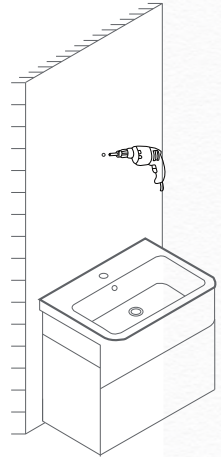

3. Percer le trou à la marque sur le mur

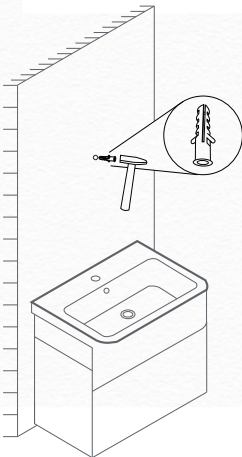

4. Clouer la cheville d'expansion dans le trou

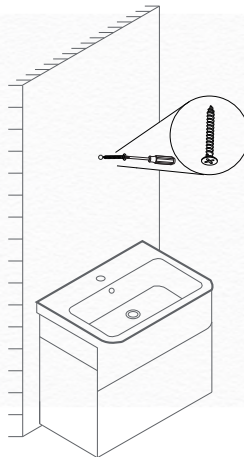

5. Serrer la vis dans la cheville



6. Accrocher le miroir

Méthode d'installation du miroir de salle de bain carré (vertical ou horizontal)



Bande d'Acier



Crayon



Perceuse électrique



Marteau



Tournevis



Sachet de Vis

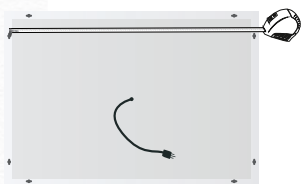

1. Mesurer la distance entre les deux trous à accrocher

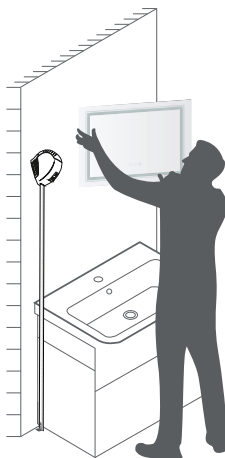

2. Soulever le miroir et mesurer la hauteur préférée

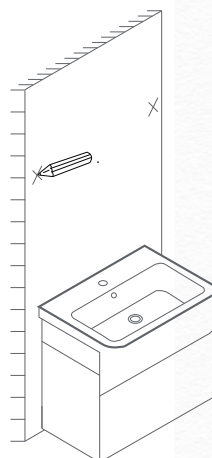

3. Marquer sur le mur avec le crayon

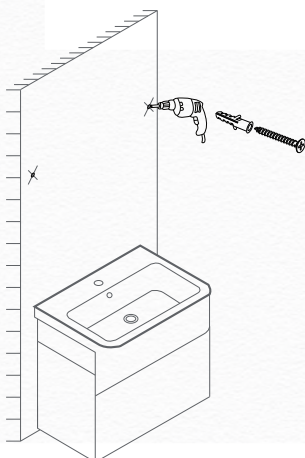

4. Percer le trou à la marque sur le mur, et clouer la vis à expansion dans le trou

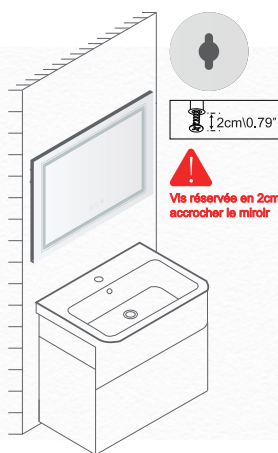

5. Accrocher le miroir



Le miroir peut même être accroché verticalement en fonction de cette méthode sudite

Espejo Baño LED, Hace la vida policromada.

Nos esforzamos por ofrecer un valor real a nuestros clientes a través de un diseño distintivo, de calidad premium y servicio de cliente excelente.

Antivaho /Luz regulable/ Función de memoria/Garantía de 3 años

Nuestro espejo es la mejor opción para su cuarto de baño, habitación, Tocado, Vestitario, etc.



- ▶ Implementamos estrictamente el control de calidad para garantizar que los productos sean 100% seguros y calificados.
Cuando recibe el espejo y encuentra cualquier duda o problema, no se olvide de poner en contacto con nosotros por email.
- ▶ Si está satisfecho con el espejo, bienvenido a compartirlo en las redes sociales. Esperamos sus comentarios y opiniones, así como sus sugerencias para nosotros.

CONSEJOS

1. Si tiene cualquier duda o problema, podría poner en contacto a nuestro servicio al cliente, estamos dispuesto para resolver su problema.
2. Después de que llegue el espejo, si encuentra alguno componente electrónico dañado, no se preocupe, porque es muy fácil de reemplazar, pone en contacto con nosotros, por favor. estaremos encantados de resolverlo.



El cableado debe ser instalado por electricistas profesionales y calificados.

- Si tengáis más consejos sobre este espejo, podríamos daros el consejo por email a nuestro compañero de atención del cliente

Q & A

Si encuentra cualquier problema a nuestro espejo, antes de devolverlo, pongase en contacto con nosotros primero, por favor.

Q1: ¿Qué debo hacer si el espejo hubiere dañado después de recibirlo?

A: Cuando recibirá el espejo dañado, haga foto y pongase en contacto con nuestro servicio del cliente, le resolveríamos dentro de 48 horas.

Q2: ¿Qué debo hacer si la función de antivaho no funciona?

- A: 1. Confirma el interruptor de antivaho si está encendido (si está encendido, el interruptor tiene color blanco).
2. La función de antivaho debe encenderse antes de 5 minutos para que funcione. Tenga paciencia, ¡ por favor!
3. Si todavía no funciona el antivaho, pongase en contacto con nuestro servicio al cliente.

Q3: ¿Qué debo hacer si falla el botón del espejo del baño?

- A: 1. Abre el panel detrás del espejo, Compruebase si el interruptor está desplazado. Si está desplazado, restaura el interruptor en su propio sitio.
2. Si el interruptor está mal cableado, vuelve a cablearlo.

Q4: ¿Qué debo hacer si la tira de luz interior en el espejo del baño se cae?

A: No dude de ponerse en contacto con nuestro servicio de cliente, le resolveríamos su problema rápidamente.

Q5: ¿Qué debo hacer si el espejo del baño instalado por cableado no funciona?

A: Confirme si el cableado del cable neutro y el cable vivo es correcto.

Q6: ¿Qué debo hacer si el panel posterior del espejo del baño está agrietado?



A: Pongase en contacto con nuestro servicio al cliente, le enviaremos cinta impermeable especial para repararlo.

Q7: ¿Cómo hacer el mantenimiento diario al espejo?

A: Limpialo con un paño limpio humedecido en agua.

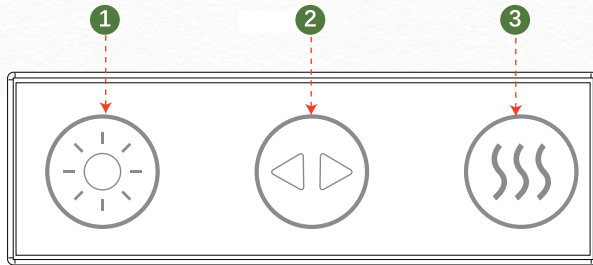
Instruction du produit



- 1  Botón de encendido - Toque para encender y apagar/ mantenga pulsado para ajustar el brillo
- 2  Botón de interruptor de luz: pulsa el botón central para seleccionar diferentes luces, luz blanca, luz neutra, luz cálida.
- 3  Botón de antivaho - Toque para encender la función de antivaho

Introducción del interruptor principal

05

Botón de encendido - para encender ajustar la luz



Toque para encender y apagar
Mantenga pulsado para ajustar el brillo

*Cuando la luz está activa, el interruptor tiene color blanco.

*Cuando la luz está apagado, el interruptor tiene color amarillo.

Botón de cambiar de luz – para regular el color de luz



Toque para cambiar la luz entre luz frío/ luz blanca/ luz cálida

*Antes de ajustar la luz tiene que encender el interruptor .

Introducción de la función antivaho

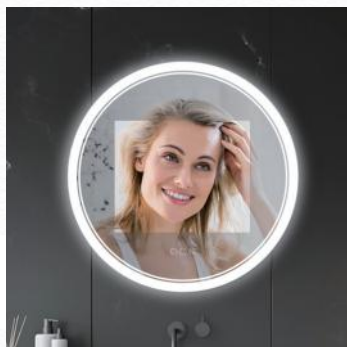

Presione para activar la función de antivaho.

Temperatura constante de la función antivaho: 38°C-45°C

*Con este botón podría activar o apagar la función de antivaho separadamente.

Función de memoria



* La luz tiene función memoria, agaga la luz cuando ya tiene el la luz preferida ajustado, si enciendela la próxima vez, la luz predeterminada es la luz ajustada.

06

Instalación del espejo

Altura ooptima

1. Antes de instalar el espejo, cogelo primero (si el producto pesa mucho pide ayuda con otras personas), ajústelo bien con la altura preferida y marcarlo con su lápiz, así facilita su instalación.
2. Superación para buscar la mejor ubicación de la instalación: mantenga su cara en el medio del espejo (refiere a la imagen derecha)



Método de conectar el cable

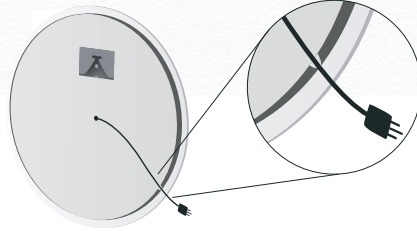
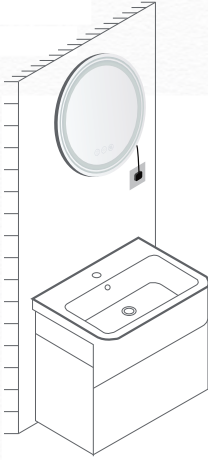

MODO 1

Extienda el cable del espejo desde su parte lateral, enchufalo

Para reducir el riesgo de estrangulamiento, los cables flexibles conectados a este dispositivo deben asegurarse de manera efectiva a

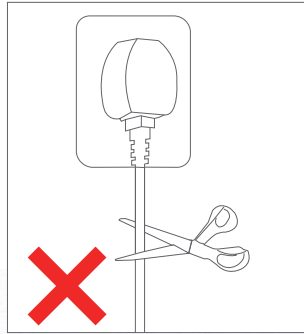
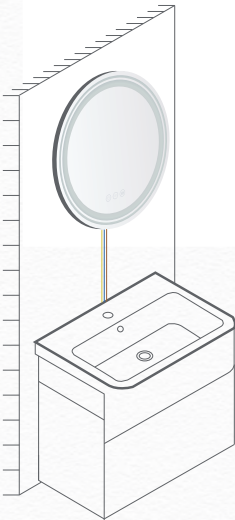

MODO 2

1. El cableado debe ser instalado por electricistas profesionales y calificados.
2. Utilice cinta aislante para proteger los cables.

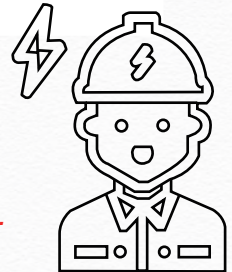

	AU	US	EU	UK	TP	JP
L					Don't need to distinguish the wiring colors	
N						
E						

El método de instalación para el espejo de baño redondo (se aplica al espejo oval también)



Cinta métrica



lápiz



taladro eléctrico



martillo



destornillador



paquete de tornillos (suplementario)



1. Coge el espejo de baño, mide su altura de instalación con la cinta métrica

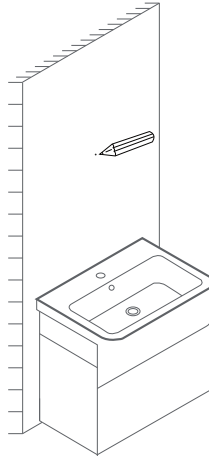

2. Marca lo con su lápiz.

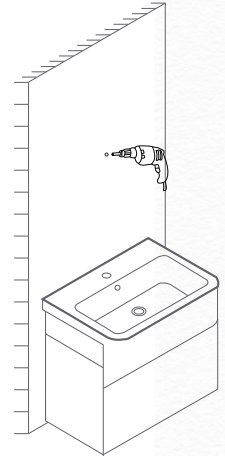

3. Taladre agujeros en los puntos marcados con un taladro eléctrico.

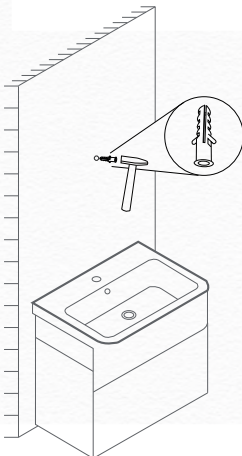

4. Inserte el clavo de expansión en el orificio

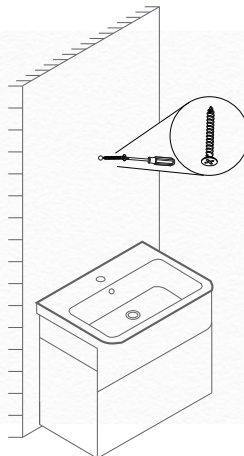

5. Inserte el tornillo en el orificio



6. Coloca el espejo

Método de instalación para el espejo rectangular (podría colgarlo en posición vertical)



Cinta métrica



lápiz



taladro eléctrico



martillo



destornillador



paquete de tornillos (suplementario)

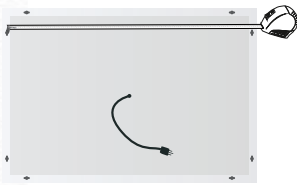

1. Mide la distancia del gancho para el espejo de baño

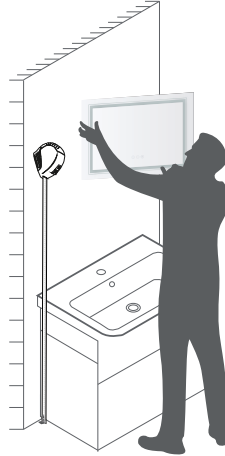

2. Levanta al espejo del baño, confirma la altura lo que quiere.

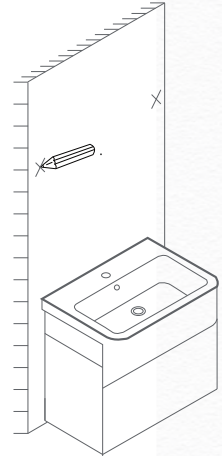

3. Marcar la altura con un lápiz.

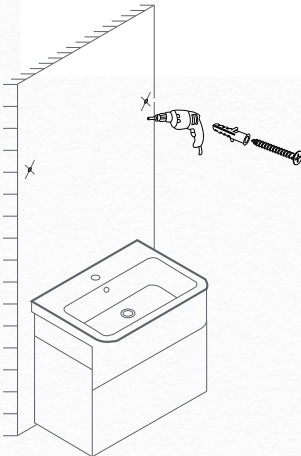

4. Utilice un taladro eléctrico para hacer agujeros en los puntos marcados e introduzca tornillos en los agujeros.



5. Coloca el espejo

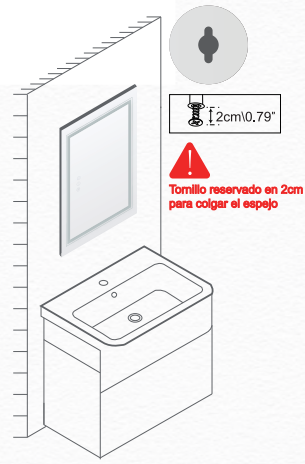

Con el mismo modo podría colocarlo en forma vertical

브랜드 소개

욕실 거울, 인생 폴리크롬 만들기
우리는 독특한 디자인을 통해 고객에게 진정한 가치를 제공하기 위해 노력하고 있습니다,
실물을 반영한 가격으로 최고의 품질과 우수한 고객 서비스
우리 제품의 가치.

김서림 방지/조광 조명/메모리 기능/3년 보증
욕실, 침실, 화장실에 완벽한 선택



- ▶ 제품이 **100%** 안전하고 품질이 우수하도록 품질관리를 철저히 하고 있습니다.
거울을 받으셨을 때 문제가 있으시면 언제든지 이메일로 연락 주시기 바랍니다.
- ▶ 거울이 마음에 드신다면 **SNS**에 공유해주시면 감사하겠습니다.
귀하의 의견과 비디오 피드백, 제안을 기다리겠습니다.

02

주의 사항

1. 거울에 대해 궁금한 점이 있으시면 이메일을 보내주시면 문제 해결을 도와드리겠습니다.
2. 전자 부품이 손상된 경우 우리에게 연락하여 다시 보내드리겠습니다.



**배선은 반드시 전문가를
청하여 설치하기 권장합니다.**

- ▶ 제안이나 조언이 있으시면 언제든지 고객 서비스로 이메일을 보내주시기 바랍니다.

03

Q & A

거울을 받은 후 문제가 있으면 고객 서비스에 먼저 문의하십시오. 우리는 48시간 이내에 문제를 해결해드리겠습니다.

Q1: 소포를 받은 후에 거울이 깨졌다면 어떻게 합니까?

A: 사진을 찍고 저희 고객 서비스에 연락하시면 48시간 이내에 처리해드리겠습니다.

Q2: 디포그 기능이 작동하지 않는다면 어떻게 해야 합니까?

- A: 1. 스위치가 켜져 있는지 확인합니다(흰색은 커튼을 의미함)
2. 작업 시작까지 5분이 지나면 디포그 기능을 켜야 합니다. 잠시만 기다려 주십시오.
3. 그래도 작동이 안 되면 고객 서비스에 문의하십시오.

Q3: 욕실 거울 버튼이 작동하지 않습니까?

- A: 1. 욕실 미러 뒤쪽 커버를 열고 스위치가 떨어졌는지 확인하고 스위치가 이동하면 위치를 복원합니다.
2. 연결 상태가 좋지 않으면 다시 배선하십시오.

Q4: 욕실 거울의 내부 조명 스트랩이 벗겨지는 경우?

A: 저희 고객 서비스에 연락해 주십시오. 빠른 시일 내에 해결해 드리겠습니다.

Q5: 배선 후 욕실 거울이 작동하지 않으면 어떻게 해야 하나요?

A: : 고객 서비스에 문의해 주십시오. 방수 수리 보조금을 보내드리겠습니다.

Q6: 거울 뒷면의 욕실 균열하면 어떻게 할 수 있습니까?



A: 고객 서비스에 문의해 주십시오. 방수 수리 보조금을 보내드리겠습니다.

Q7: 욕실 거울의 일상적인 유지관리 방법은 무엇입니까?

A: 더스트 천을 사용하고 따뜻한 물로 닦으면 됩니다.

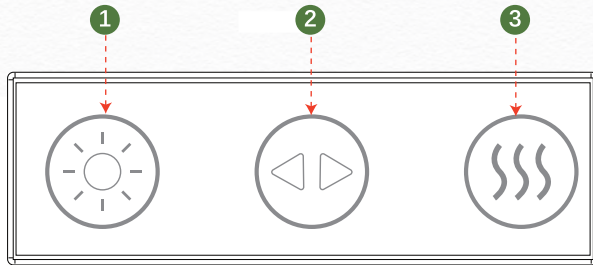
제품 소개



- 1  On/Off 스위치 - ON/OFF 버튼을 짧게 누르면 밝기가 조정됩니다
- 2  색온도 전환 버튼: 중간에 있는 색온도 전환 버튼을 누르시면 주광색-주백색-전구색 3색을 조정하실 수 있습니다.
- 3  김서림 방지 버튼 - 이 버튼을 누르면 가열되기 시작하고 김서림을 제거할 수 있습니다.

기능 설명

05

기능에 대한 자세한 설명-열선내장 자동 디포 기능 설명



켜짐/꺼짐 버튼을 짧게 누릅니다. 길게 누르면 밝기가 조정됩니다.

*On-Off 키의 경우 흰색(on-state), 노란색(off-state)은 노란색(off-state)입니다

조명 변경 버튼 - 다양한 조명 조정



버튼을 짧게 누르면 전구색-주백색-주광색
조명 색상이 조정됩니다

* 색온도를 전환하려면 전원 키를 켜야 합니다

열선내장 자동 디포 기능 설명

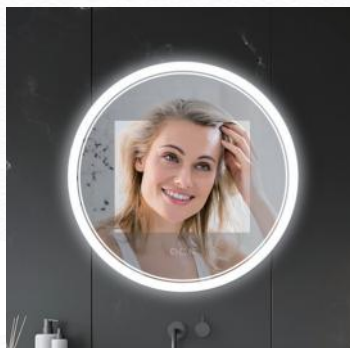

누르면 김서림 기능이 열립니다

미러 온도 유지 : 38 C-45 C

*불을 켜지 않아도 김서림 제거 기능을 사용할 수 있습니다

메모리 기능



*미러는 메모리 기능이 있으며 다음 번에 불을 켜면 지난번과 같은 색상의 조명이 됩니다.

제품 설치

06

권장 높이

1. 화장실에서 거울 설치 시 먼저 거울을 들고 설치 높이를 확인해서 표시되고 나서 펀치를 하면 됩니다.
2. 거울은 얼굴 바로 앞에 있는 위치에서 설치하기 권장합니다.

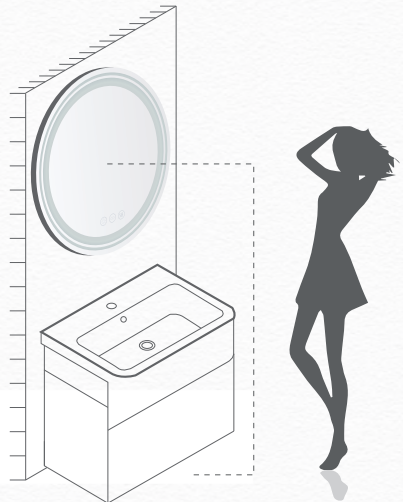

배선 방법

07

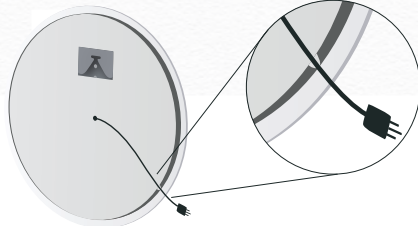
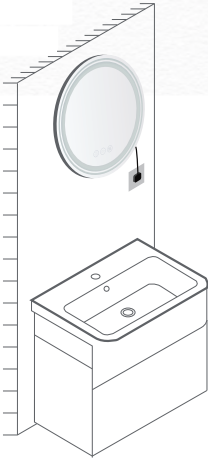

방법 1

거울의 라인을 측면의 홈에서 연장하여 사용할 수 있도록 플러그를 끼웁니다

감김에 의한 질식의 위험을 방지하기 위하여 케이블이 손이 닿을 수 있는 곳에 위치하였을 때 이 램프와 연결된 유연성 케이블을 벽에 효과적으로 고정하여야 하십시오.

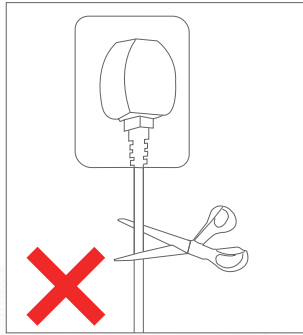
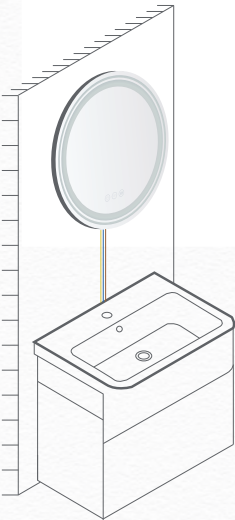

방법 2

1. 배선은 반드시 전문가를 청하여 설치하기 권장합니다.
2. 절연체 테이프로 선을 보호해 주십시오.

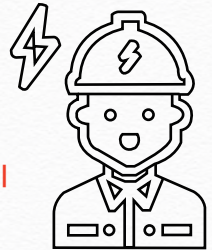

	AU	US	EU	UK	TP	JP
L					배선 색상을 구분할 필요가 없습니다	
N						
E						✗

원형/타원형 욕실 거울 설치



줄자



연필



드릴



망치



스크루드라이버



나사 키트(세트)

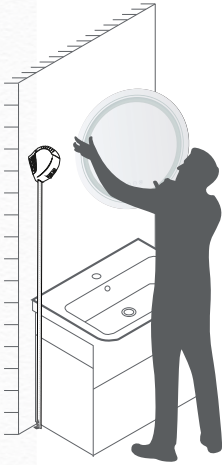

1. 줄자로 최적의 설치 높이 측정

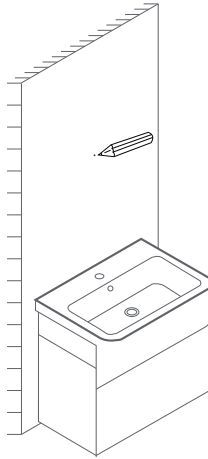

2. 연필로 벽에 표시하기

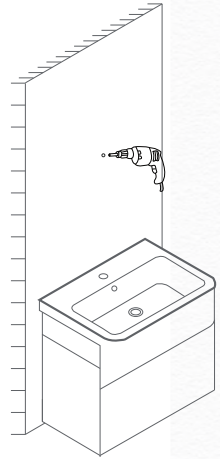

3. 전기 드릴로 마크를 천공합니다

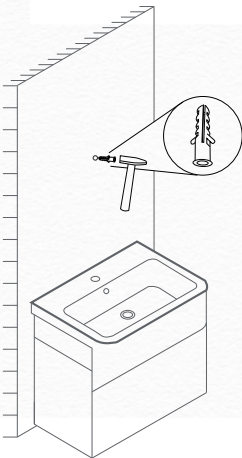

4. 팽창 고무 플러그를 구멍에 넣습니다

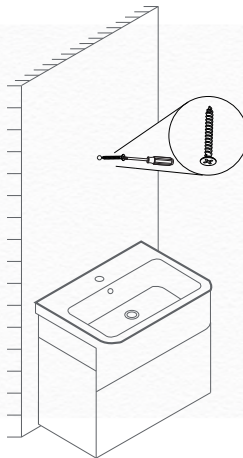

5. 나사를 구멍에 박습니다



6. 거울을 걸습니다

사각 욕실 거울(수직/수평)



줄자



연필



드릴



망치



스크루드라이버



나사 키트(세트)

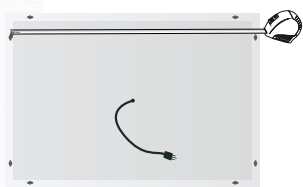

1. 욕실 미러 후크의 거리를 측정합니다.

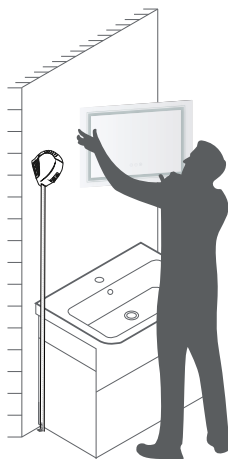

2. 욕실 미러를 위로 들어 올려 최적의 장착 높이를 확인합니다.

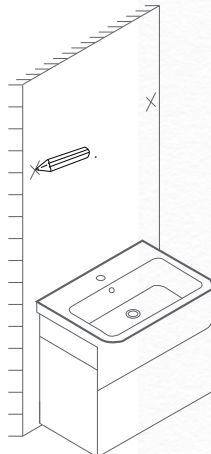

3. 연필로 벽에 표시하기

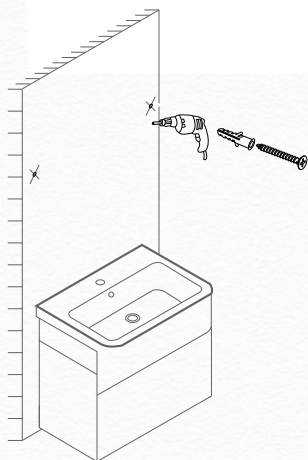

4. 전기 드릴로 마크를 드릴로 친공합니다. 나사와 팽창 플러그를 구멍에 박습니다.

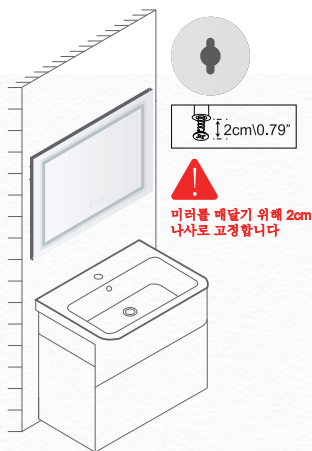

5. 화장실 거울을 걸어 놓으세요.

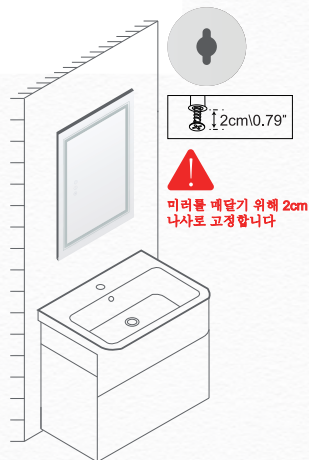

같은 방법으로 세로로 매달 수 있습니다

미러를 매달기 위해 2cm
나사로 고정합니다

Introduzione Del Marchio

specchio da bagno led rende la vita colorata

Ci impegniamo a fornire ai nostri clienti un vero valore attraverso un design unico, una qualità superiore e un servizio clienti eccezionale a prezzi che riflettono il vero valore dei nostri prodotti.

Antiappannamento/dimmerabile/funzione memoria/3 anni di garanzia, scelta perfetta per bagno e camera da letto.



► Implementiamo rigorosamente il controllo di qualità per garantire che i nostri prodotti siano sicuri e qualificati al 100%.

In caso di problemi quando ricevi lo specchio, non esitare a contattarci.

► Se sei soddisfatto del specchio, sentiti libero di condividerlo sui social media.

Grazie per il tuo feedback e i tuoi suggerimenti per noi.

Promemoria Importante

1. Se hai domande sullo specchio del bagno, puoi contattare il servizio clienti. Saremo felici di risolvere il tuo problema.
2. Se noti che qualche componente elettronico è danneggiato dopo l'arrivo dello specchio del bagno, non preoccuparti, la sostituzione è molto semplice, saremo felici di risolverlo per te.

► Se hai opinioni migliori sul prodotto, puoi contattare il servizio clienti.



Il cablaggio deve essere installato da elettricisti professionisti e qualificati.

Q & A

In caso di problemi con lo specchio del bagno, non restituirlo direttamente. Contatta il servizio clienti il prima possibile e risolveremo il problema entro 48 ore.

Q1: Cosa devo fare se vedo che lo specchio del bagno è danneggiato dopo averlo ricevuto?

A: Se dopo aver aperto la confezione vedi che lo specchio del tuo bagno è danneggiato, non preoccuparti. Contatta il servizio clienti e allega immagini, risolveremo il problema entro 48 ore.

Q2: La funzione di disappannamento non funziona, cosa devo fare?

1. Controllare se il pulsante di disappannamento è attivo (il display bianco è acceso).
2. La funzione di disappannamento deve essere attivata per 5 minuti prima che possa avere effetto, attendere pazientemente.
3. Se la funzione di disappannamento continua a non funzionare, contattare il servizio clienti.

Q3: Cosa devo fare se il pulsante dello specchio del bagno non funziona?

1. Apri il pannello posteriore dello specchio del bagno e controlla se l'interruttore è spostato. Se l'interruttore è spostato, basta ripristinarlo.
2. Il cablaggio dell'interruttore è difettoso, basta ricablarlo.

Q4: Cosa devo fare se la striscia luminosa interna dello specchio del bagno cade?

A: Non preoccuparti, contatta il servizio clienti e risolveremo rapidamente tali problemi.

Q5: Lo specchio del bagno installato utilizzando il metodo di cablaggio non funziona, cosa devo fare?

A: Verificare se il cablaggio del filo neutro e del filo sotto tensione è corretto.

Q6: Sono presenti delle crepe sul pannello posteriore dello specchio del bagno, cosa devo fare?



A: Contatta il nostro servizio clienti, ti invieremo uno speciale nastro impermeabile per ripararlo.

Q7: Come mantenere quotidianamente gli specchi del bagno?

A: Puoi pulirlo con un panno privo di lanugine imbevuto di acqua tiepida.

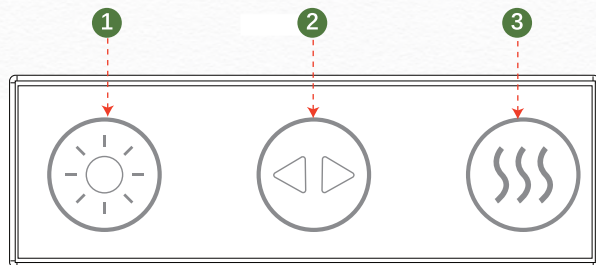
Introduzione del prodotto



- 1  Interruttore on/off - Premere brevemente il pulsante on/off. Premere a lungo per regolare la luminosità.
- 2  Pulsante interruttore luce: premere il pulsante centrale per selezionare luci diverse, luce bianca/luce naturale/luce calda
- 3  Pulsante antiappannamento - Premere il pulsante della funzione antiappannamento

Introduzione dettagliata della funzione specchio

Pulsante interruttore - controllo e regolazione della luminosità



Toccare per accendere e spegnere. Premere a lungo per regolare la luminosità

* Pulsante interruttore, bianco significa stato acceso, giallo significa stato spento

Pulsante cambio luce - regola luci diverse

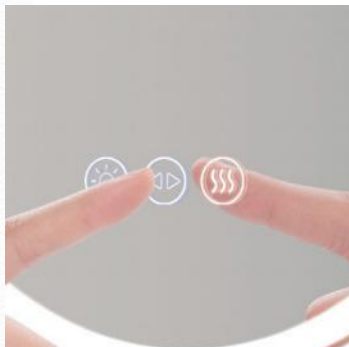

Premere brevemente il pulsante per regolare il colore da bianco/bianco caldo/luce calda

* È necessario attivare il pulsante interruttore per cambiare la temperatura del colore

Introduzione della funzione di disappannamento

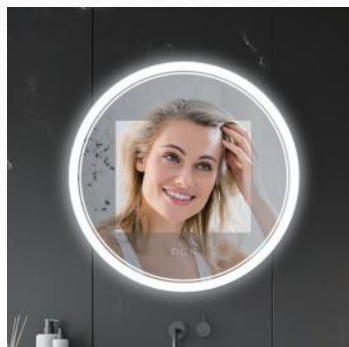

Toccare per aprire la funzione di antiappannamento dello specchio

Temperatura costante di antiappannamento dello specchio: 38 °C - 45 °C

* La funzione antiappannamento può essere utilizzata separatamente e può essere disattivata separatamente quando non in uso

Funzione di memoria



Lo specchio è dotato di funzione di memoria, la prossima volta che accendi la luce, il colore dell'illuminazione sarà lo stesso dell'ultima.

06

Installazione del prodotto

Consiglia altezza

1. Quando si installa lo specchio del bagno, prendere prima lo specchio del bagno e confermare la migliore altezza di installazione per contrassegnare, quindi perforare per l'installazione
2. Assicurati che il tuo viso sia al centro dello specchio per un'immagine migliore.



Metodo di cablaggio

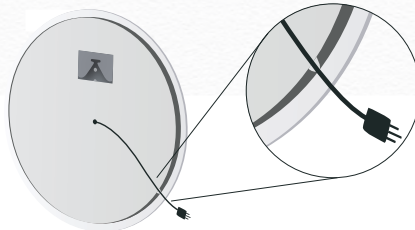
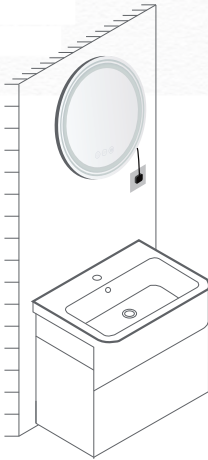

Metodo 1

Estendi la linea dello specchio da bagno dalle scanalature laterali e collegalo per l'uso.

Per ridurre il rischio di strangolamento, i cavi flessibili collegati a questo apparecchio devono essere fissati efficacemente alla parete quando il cavo si trova nella zona delle mani

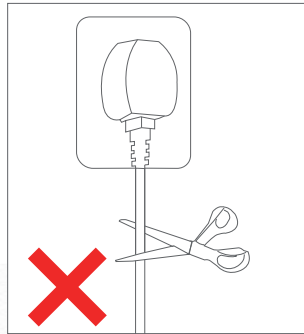
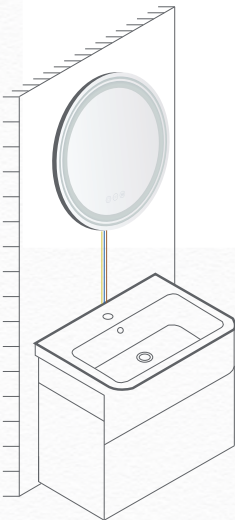

Metodo 1

1. Il cablaggio deve essere installato da elettricisti professionisti e qualificati.
2. Utilizzare nastro isolante per proteggere i cavi

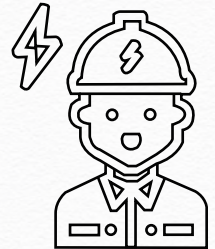

	AU	US	EU	UK	TP	JP
L					Don't need to distinguish the wiring colors	
N						
E						

Installazione di specchio da bagno rotondo/ovale



Metro a nastro



Matita



Trapano elettrico



Martello



Cacciavite



Kit viti (set)

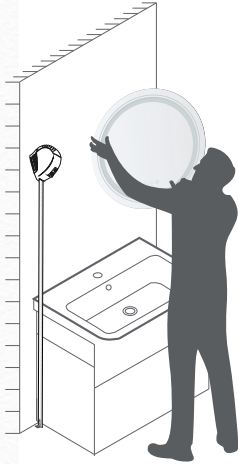

1. Misurare l'altezza di installazione migliore con un metro a nastro

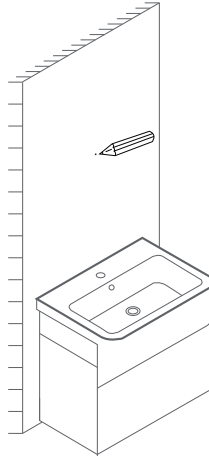

2. Segna il muro con una matita

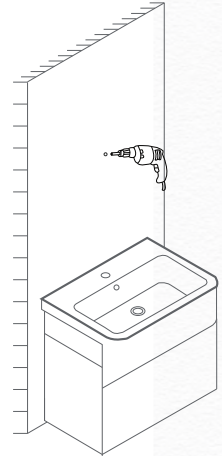

3. Utilizzare un trapano elettrico per praticare i fori nei punti contrassegnati

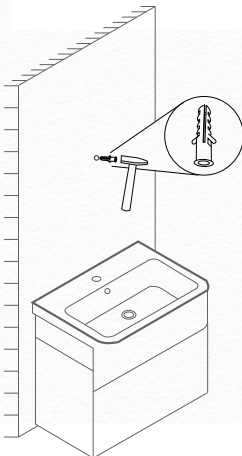

4. Inserire le viti di espansione nel foro.

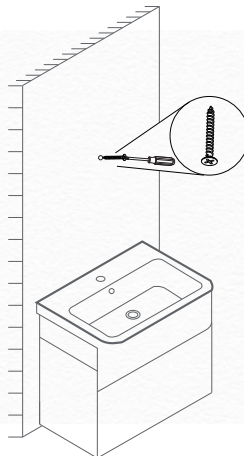

5. Inserire una vite nel foro.

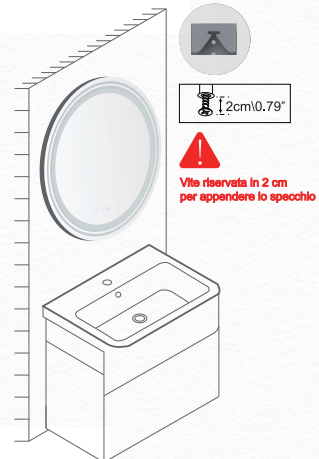

6. Appendere lo specchio del bagno.

Specchio da bagno rettangolare (verticale/orizzontale)



Metro a nastro



Matita



Trapano elettrico



Martello



Cacciavite



Kit viti (set)

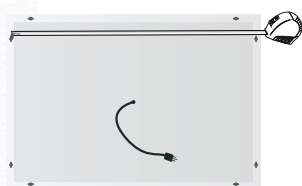

1. Misurare la distanza del gancio dello specchio del bagno.

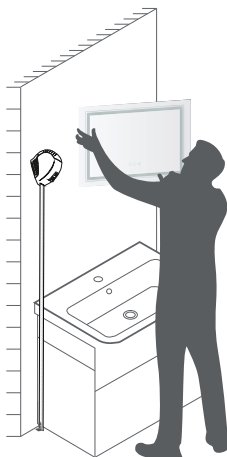

2. Sollevare lo specchio del bagno per confermare la migliore altezza di montaggio.

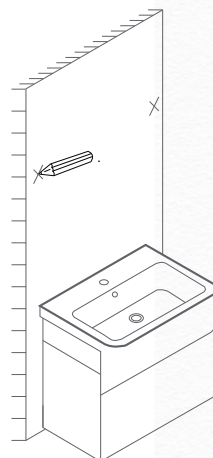

3. Segna il muro con una matita.

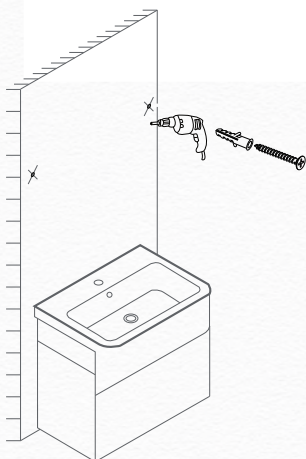

4. Utilizzare un trapano elettrico per praticare i fori nei punti contrassegnati, e inserire le viti di espansione e vite nel foro

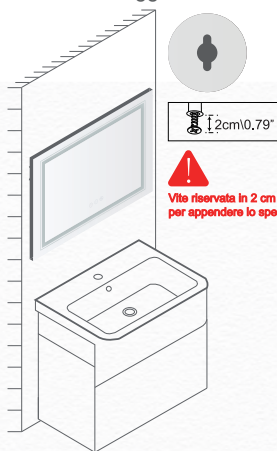

5. Appendere lo specchio del bagno.

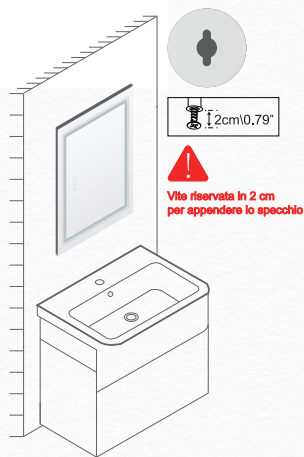

Puoi appenderlo verticalmente
allo stesso modo

After-sale Service Card



Notice:

Do not directly place the sharp glass corner of the mirror to the floor, recommend to put some cardboard or cushions on the floor to avoid damage and scratches.

Hinweise zur Aufstellung:

Vermeiden Sie den direkten Kontakt von scharfen Glasrändern mit dem Boden indem Sie Verpackungsmaterial oder weiche Unterlagen verwenden, um Schäden oder Kratzer zu verhindern.

取扱上の注意事項:

鏡の損壊や床傷を防止するため、鏡の角部分を地面に当てないでください。段ボールや絨毯の上に置いて開封した方がおすすめです。

Notice :

Évitez le contact direct des bords tranchants du verre avec le sol en utilisant des matériaux d'emballage ou des tampons souples pour éviter tout dommage ou rayure.

Nota:

No coloque el vidrio de borde afilado directamente sobre el suelo. Se recomienda colocar algo de cartón duro o un cojín en el suelo para evitar daños y arañazos.

취급시 주의사항 :

날카로운 유리 모서리를 바닥에 직접 놓지 말고 바닥에 포장재나 쿠션으로 바닥에 직접 닿아 손상이나 긁힘을 방지해야 합니다.

Nota:

Non posizionare il vetro con angoli appuntiti direttamente sul pavimento. Si consiglia di mettere del cartone rigido o un cuscino sul pavimento per evitare danni e graffi.



Cleaning Tips:

1. If there are stains on the mirror surface, you can use toothpaste or window cleaner first, then wipe it clean with a microfiber cloth.
 2. Wipe off with 30% cleaning diluent.
 3. If there are adhesive residue on the surface, carefully remove it using a knife.
- Dear customers, please refer to these cleaning tips mentioned if you received the products in the above situation. If you have any further questions, welcome to contact our customer service for help. We wish you a happy life.

Tipps zur Reinigung:

1. Zur Reinigung von Flecken auf dem Spiegel können Sie Zahnpasta oder Glasreiniger verwenden und diese mit einem sauberen Tuch abwischen. Alternativ kann eine 30%ige Reinigungslösung verwendet werden.
 2. Klebstoffreste auf der Glasoberfläche können vorsichtig mit einem schrägen Schnittmesser entfernt werden.
- Sehr geehrter Kunde, bei Problemen mit Ihrem Produkt, wie oben beschrieben nutzen Sie die genannten Pflege- und Reinigungstipps. Bei weiteren Fragen steht Ihnen unser Kundendienst gerne zur Verfügung. Wir wünschen Ihnen eine angenehme Zeit.

お手入れとメンテナンスについて:

1. 万が一、鏡面には汚れが付きましたら、歯磨き粉やガラス用洗剤を塗りつけてから、雑巾などで拭き取ってください。
2. ガラス用洗剤など3倍ぐらい希釈してからご使用ください。
3. 万が一、鏡面にはガラス用接着剤などの跡が付きましたら、へら状の小物で除いてください。もし、商品について、まだ何かご質問がありましたら、お気軽にご連絡ください。

Conseils de nettoyage :

1. Pour nettoyer les taches sur le miroir, vous pouvez utiliser du dentifrice ou un nettoyant pour vitres et l'essuyer avec un chiffon propre. Alternativement, une solution de nettoyage à 30 % peut être utilisée.

2. Les résidus d'adhésif sur la surface du verre peuvent être soigneusement éliminés à l'aide d'un couteau coudé.

Cher client, si vous rencontrez des problèmes comme décrit ci-dessus, utilisez les conseils d'entretien et de nettoyage mentionnés. Si vous avez d'autres questions, notre service client se fera un plaisir de vous aider. Nous vous souhaitons une bonne vie.

Avisos para la limpieza :

1. Si la superficie del espejo tiene manchas, puede usar pasta de dientes o limpiacristales, y luego limpiar con un paño de microfibra.

2. Limpiar con una solución de limpieza diluida al 30%.

3. Si hay residuos de adhesivo en la superficie, elimínelos con cuidado con un cuchillo.

Estimado cliente, si recibe el producto en estas condiciones, siga los consejos de limpieza anteriores. Si tiene alguna pregunta, no dude en ponerse en contacto con nuestro servicio de atención al cliente. Le deseamos una vida feliz.

관리 및 유지 보수에 대해서 :

1 : 만일 거울 표면에는 오염이 묻으면 치약이나 유리세제를 바른 후 걸레 등으로 닦아내 주십시오.

2 : 유리세제 등 30% 정도 희석하신 후 사용하시기 바랍니다.

3 : 만일 거울면에는 유리용 접착제 등의 자국이 나면 주걱 모양의 소품으로 제외해 주십시오.

상품에 대해 더 궁금하신 점 있으시면 편하게 연락주세요.

Avvertenze per la pulizia :

1. Se la superficie dello specchio è macchiata, è possibile utilizzare prima del dentifricio o un detergente per vetri, quindi pulire con un panno in microfibra.

2. Pulire con diluente detergente al 30%.

3. Se ci sono residui di adesivo sulla superficie, rimuoverli attentamente con un coltello.

Gentile cliente, se ricevi un prodotto nella situazione sopra descritta, fai riferimento ai suggerimenti per la pulizia sopra indicati. In caso di domande, non esitate a contattare il nostro servizio clienti. Ti auguriamo una vita felice.

Information on electrical and electronic equipment

The following information is intended for users of electrical and/or electronic equipment in private households.

1. Separate collection of waste equipment

Electrical and electronic equipment that has become waste is referred to as old equipment. Owners of WEEE must dispose of it separately from unsorted municipal waste. Old appliances do not belong in the household waste, but in special collection and return systems.

2. Batteries and rechargeable batteries as well as lamps

As a rule, owners of old appliances must separate old batteries and accumulators that are not enclosed in the old appliance, as well as lamps that can be removed from the old appliance without destroying it, from the old appliance before handing it in at a collection point. This does not apply if the WEEE is handed over to public waste management authorities and separated from other WEEE there for the purpose of preparation for reuse.

3. Possibilities for the return of old devices

If you have old appliances, you can hand them in at the facilities set up and available by public waste disposal authorities for the return or collection of old appliances for the purpose of proper disposal of the old appliances. If necessary, it is also possible to hand in electrical and electronic equipment there for the purpose of reusing the equipment. For more information, please contact the respective collection or take-back point.

4. Data protection notice

Old devices often contain sensitive personal data. This applies to information and telecommunications technology devices such as computers and smartphones. In your own interest, please note that each end user is responsible for deleting the data on the old devices to be disposed of.

5. Meaning of the symbol "crossed-out dustbin"

The symbol of a crossed-out wheeled garbage can regularly on electrical and electronic equipment indicates that the respective device must be collected separately from unsorted municipal waste at the end of its service life.



Informationen zu Elektro- und Elektronikgeräten

Der nachstehende Hinweis richtet sich an private Endnutzer, die Elektro- und/ oder Elektronikgeräte nutzen.

1. Getrennte Erfassung von Altgeräten

Elektro- und Elektronikgeräte, die zu Abfall geworden sind, werden als Altgeräte bezeichnet. Besitzer von Altgeräten haben diese einer vom unsortierten Siedlungsabfall getrennten Erfassung zuzuführen. Altgeräte gehören insbesondere nicht in den Hausmüll, sondern in spezielle Sammel- und Rückgabesysteme.

2. Batterien und Akkus sowie Lampen

Besitzer von Altgeräten haben Altbatterien und Altakkumulatoren, die nicht vom Altgerät umschlossen sind, sowie Lampen, die zerstörungsfrei aus dem Altgerät entnommen werden können, im Regelfall vor der Abgabe an einer Erfassungsstelle von diesem zu trennen. Dies gilt nicht, soweit die Altgeräte bei öffentlich-rechtlichen Entsorgungsträgern abgegeben und dort zum Zwecke der Vorbereitung zur Wiederverwendung von anderen Altgeräten repariert werden.

3. Möglichkeiten der Rückgabe von Altgeräten

Wenn Sie Altgeräten besitzen, können Sie an den durch öffentlich-rechtliche Entsorgungsträger eingerichteten und zur Verfügung stehenden Möglichkeiten der Rückgabe oder Sammlung von Altgeräten zum Zwecke der ordnungsgemäßen Entsorgung der Altgeräte abgeben. Gegebenenfalls ist dort auch eine Abgabe von Elektro- und Elektronikgeräten zum Zwecke der Wiederverwendung der Geräte möglich. Nähere Informationen hierzu erhalten Sie von der jeweiligen Sammel- bzw. Rücknahmestelle.

4. Datenschutz-Hinweis

Altgeräte enthalten häufig sensible personenbezogene Daten. Dies gilt insbesondere für Geräte der Informations- und Telekommunikationstechnik wie Computer und Smartphones. Bitte beachten Sie in Ihrem eigenen Interesse, dass für die Löschung der Daten auf den zu entsorgenden Altgeräten jeder Endnutzer selbst verantwortlich ist.

5. Bedeutung des Symbols „durchgestrichene Mülltonne“

Das auf den Elektro- und Elektronikgeräten regelmäßig abgebildeten Symbol einer durchgestrichenen Mülltonne weist darauf hin, dass das jeweilige Gerät am Ende seiner Lebensdauer getrennt vom unsortierten Siedlungsabfall zu erfassen ist.



Informations sur les équipements électriques et électroniques

Les informations suivantes s'adressent aux utilisateurs d'équipements électriques et/ou électroniques dans les ménages.

1. Collecte séparée des déchets d'équipements électriques et électroniques (DEEE)

Les équipements électriques et électroniques qui sont devenus des déchets sont appelés "vieux équipements". Les propriétaires de DEEE doivent les faire collecter séparément des déchets municipaux non triés. Les vieux appareils ne doivent pas être jetés avec les ordures ménagères, mais dans des systèmes de collecte et de retour spéciaux.

2. Piles, accumulateurs et lampes

En règle générale, les propriétaires de vieux appareils doivent séparer les piles et accumulateurs usagés qui ne sont pas enfermés dans le vieux appareil, ainsi que les lampes qui peuvent être retirées du vieux appareil sans le détruire, avant de le déposer dans un point de collecte. Cette disposition ne s'applique pas si les DEEE sont remis aux autorités publiques chargées de la gestion des déchets et s'ils y sont séparés des autres DEEE en vue de leur réutilisation.

3. Possibilités de reprise des vieux appareils

Si vous possédez de vieux appareils, vous pouvez les déposer dans les installations mises en place et disponibles par les

autorités publiques chargées de l'élimination des déchets pour la restitution ou la collecte des vieux appareils en vue de leur élimination correcte. Le cas échéant, il est également possible d'y déposer des équipements électriques et électroniques en vue de leur réutilisation. Pour plus d'informations, veuillez contacter le point de collecte ou de reprise concerné.

4. Avis sur la protection des données

Les vieux appareils contiennent souvent des données personnelles sensibles. C'est le cas des appareils de technologie de l'information et de la télécommunication tels que les ordinateurs et les smartphones. Dans votre propre intérêt, veuillez noter que chaque utilisateur final est responsable de l'effacement des données sur les anciens appareils à éliminer.

5. Signification du symbole "poubelle barrée"

Le symbole de la poubelle barrée, qui figure régulièrement sur les équipements électriques et électroniques, indique que l'équipement concerné doit être collecté séparément des déchets municipaux non triés à la fin de sa durée de vie.



Informazioni sulle apparecchiature elettriche ed elettroniche

Le seguenti informazioni sono destinate agli utenti di apparecchiature elettriche e/o elettroniche in ambito domestico.

1. Raccolta differenziata dei rifiuti di apparecchiature

Le apparecchiature elettriche ed elettroniche diventate rifiuti sono definite vecchie apparecchiature. I proprietari di RAEE devono smaltirli separatamente dai rifiuti urbani indifferenziati. Le vecchie apparecchiature non vanno inserite nei rifiuti domestici, ma in speciali sistemi di raccolta e restituzione.

2. Batterie, accumulatori e lampade

Di norma, i proprietari di vecchi apparecchi devono separare le vecchie pile e gli accumulatori che non sono incorporati nel vecchio apparecchio, nonché le lampade che possono essere rimosse dal vecchio apparecchio senza distruggerlo, dal vecchio apparecchio prima di consegnarlo a un punto di raccolta. Questa disposizione non si applica se i RAEE sono consegnati alle autorità pubbliche di gestione dei rifiuti e li separati da altri RAEE ai fini della preparazione per il riutilizzo.

3. Possibilità di restituzione dei vecchi apparecchi

Se si dispone di vecchi apparecchi, è possibile consegnarli presso le strutture predisposte e disponibili dalle autorità pubbliche di smaltimento dei rifiuti per la restituzione o la raccolta di vecchi apparecchi ai fini del loro corretto smaltimento. Se necessario, è anche possibile consegnare apparecchiature elettriche ed elettroniche per il loro riutilizzo. Per ulteriori informazioni, contattare il rispettivo punto di raccolta o ritiro.

4. Avviso di protezione dei dati

I vecchi dispositivi contengono spesso dati personali sensibili. Questo vale per i dispositivi informatici e di telecomunicazione come computer e smartphone. Nel vostro interesse, vi ricordiamo che ogni utente finale è responsabile della cancellazione dei dati contenuti nei vecchi dispositivi da smaltire.

5. Significato del simbolo "pattumiera barrata"

Il simbolo di una pattumiera barrata, regolarmente esposto sulle apparecchiature elettriche ed elettroniche, indica che il rispettivo dispositivo deve essere raccolto separatamente dai rifiuti urbani indifferenziati al termine della sua vita utile.



Información sobre residuos de aparatos eléctricos y electrónicos (RAEE)

La siguiente información está destinada a los usuarios finales privados de equipos eléctricos y/o electrónicos.

1. Recogida selectiva de residuos de aparatos

Los aparatos eléctricos y electrónicos que se han convertido en residuos se denominan RAEE. Los propietarios de RAEE deben eliminarlos de forma separada de los residuos urbanos no seleccionados. En, los RAEE no deben depositarse en la basura doméstica, sino en sistemas especiales de recogida y devolución.

2. Pilas, acumuladores y lámparas

Por regla general, los propietarios de RAEE deben separar de las pilas y acumuladores usados que no estén encerrados en los RAEE, así como las lámparas que puedan extraerse de los RAEE sin destruirlos, antes de entregarlos en un punto de recogida. Esto no se aplica si los RAEE se entregan a las autoridades públicas de gestión de residuos y se separan de otros RAEE con el fin de prepararlos para su reutilización.

3. Posibilidades de devolución de RAEE

Si tiene los RAEE, puede entregarlos en las instalaciones establecidas y disponibles por las autoridades públicas de gestión de residuos para la devolución o recogida de aparatos viejos con el fin de eliminarlos adecuadamente. En caso necesario, también es posible entregar allí aparatos eléctricos y electrónicos con el fin de reutilizarlos. Para más información, póngase en contacto con el punto de recogida o devolución correspondiente.

4. Aviso sobre protección de datos

Los RAEE suelen contener datos personales sensibles. Esto se aplica en particular a los dispositivos de tecnología de la información y las telecomunicaciones, como ordenadores y teléfonos inteligentes. En su propio interés, tenga en cuenta que cada usuario final es responsable de borrar los datos de los RAEE que vaya a desechar.

5. Significado del símbolo "contenedor de basura tachado"

El símbolo de un contenedor de basura con ruedas tachado que aparece regularmente en los aparatos eléctricos y electrónicos indica que el aparato correspondiente debe recogerse por separado de los residuos urbanos sin clasificar al final de su vida útil.



