

ASSEMBLY INSTRUCTION

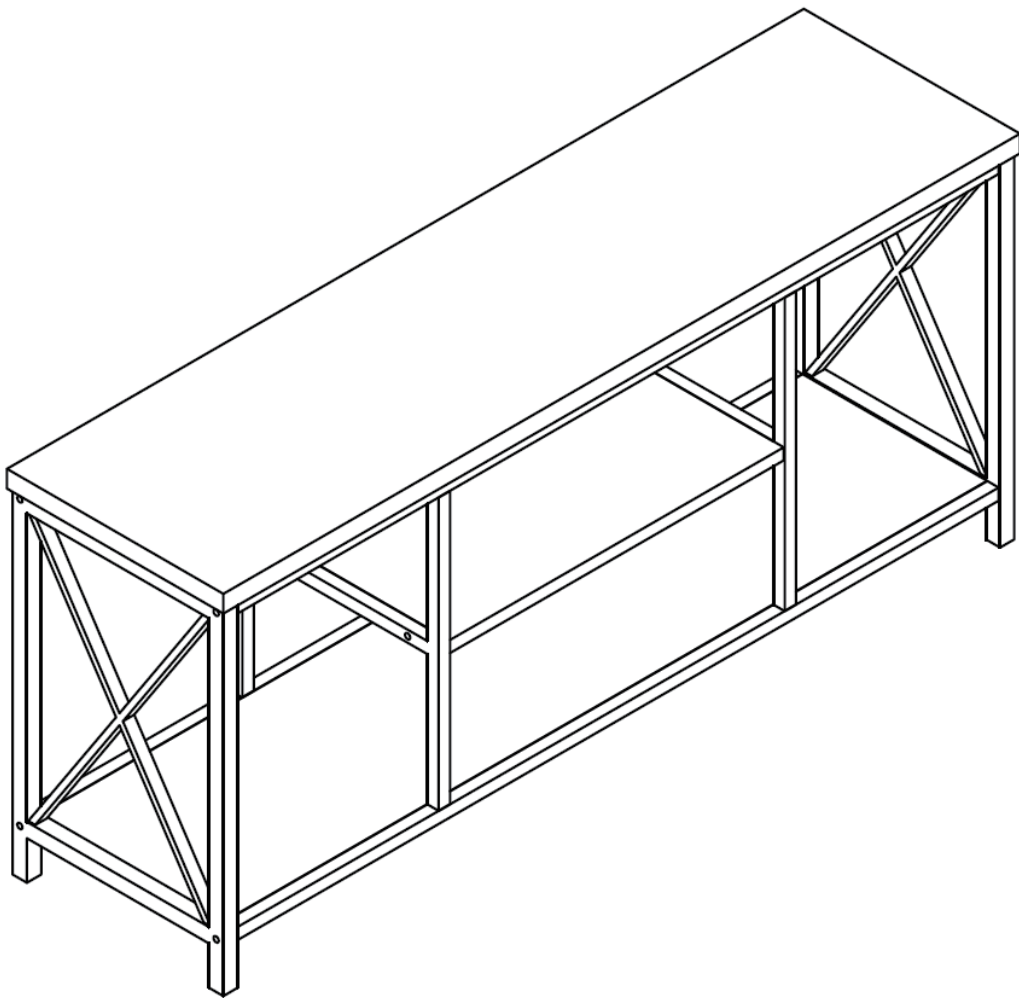







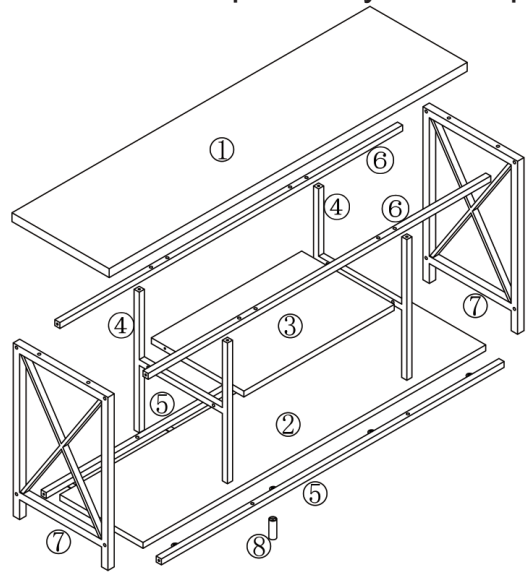
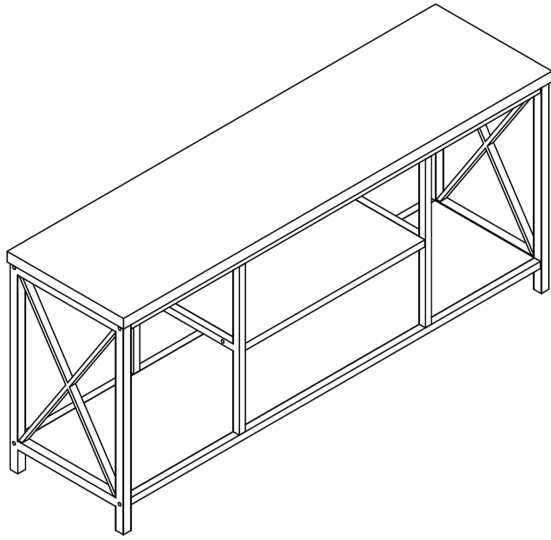

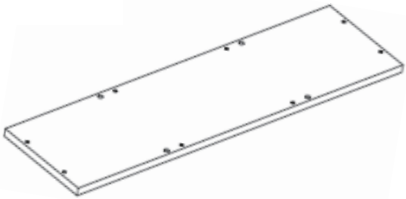
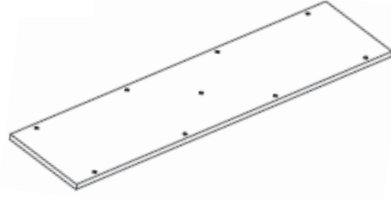
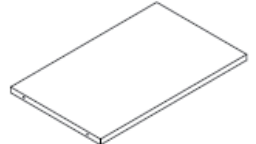
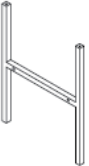
TV Stand

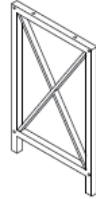

Part Identification

While not all parts are labeled, some of the parts will have a label to help distinguish similar parts from each other. Use this part identification to help identify similar parts.



 <p>① Top Panel 1 pc</p>		 <p>② Bottom Panel 1 pc</p>		 <p>③ Mid Panel 1 pc</p>	
 <p>④ Metal Leg 2 pcs</p>	 <p>⑤ Metal Tube 2 pcs</p>	 <p>⑥ Metal Rod 2 pcs</p>	 <p>⑦ Metal Frame 2 pcs</p>	 <p>⑧ Adjusting Rod 1 pc</p>	
 <p>A Allen Key M4 1 pc</p>	 <p>B Medium Bolt M6*40mm 16 pcs</p>	 <p>C Short Bolt M6*12mm 8 pcs</p>	 <p>D Screw Ø7*50mm 4 pcs</p>		
 <p>E Double End Stud M6*35mm 1 pc</p>	 <p>F Leveler M6*20mm 1 pc</p>	 <p>G Long Bolt M6*50mm 8 pcs</p>			

Step 01

NOTE: If holes don't align, loosen all bolts and adjust the holes slightly. After all holes are aligned, fully tighten all bolts.

- ✚ Lay Bottom Panel(②) on a clean smooth surface such as carpet or cardboard. Connect and fasten 2 Metal Tubes(⑤) to Bottom Panel(②) with Short Bolts(C) by Allen key(A). Fully tighten all bolts after all holes are aligned.

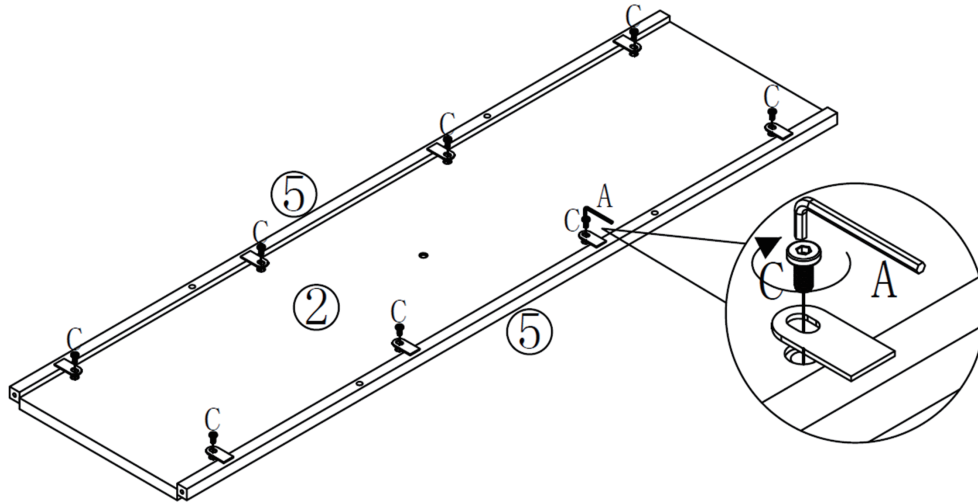

Step 02

- ✚ Screw and fasten Double End Stud(E) to Bottom Panel(②). Make sure short end of Double End Studs(E) are screwed into Bottom Panel(②). Fully tighten the Double End Stud(E).

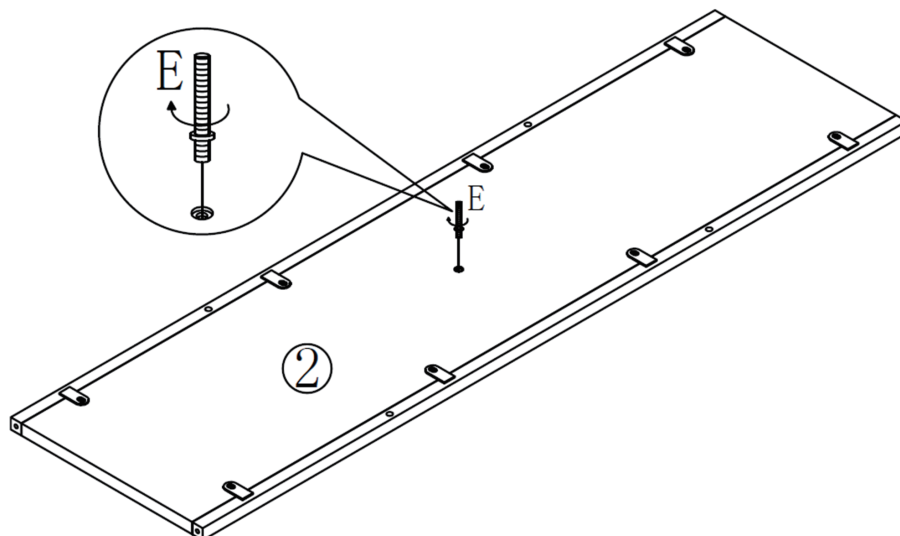

Step 03

- ✚ Screw and fasten Adjusting Rod(⑧) to Double End Stud(E). Then screw and fasten Leveler(F) to Adjusting Rod(⑧).

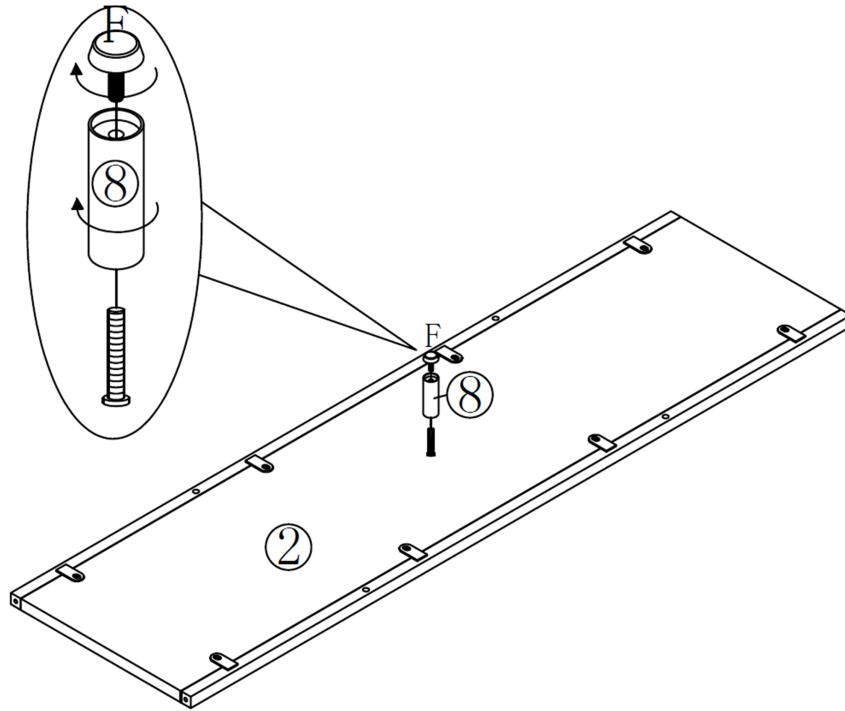

Step 04

NOTE: If holes don't align, loosen all bolts and adjust the holes slightly. After all holes are aligned, tighten all bolts.

- ✚ Connect and fasten 2 Metal Frames(⑦) to Metal Tubes(⑤) with Long Bolts(G) by Allen key(A). Tighten all bolts while all holes are aligned.

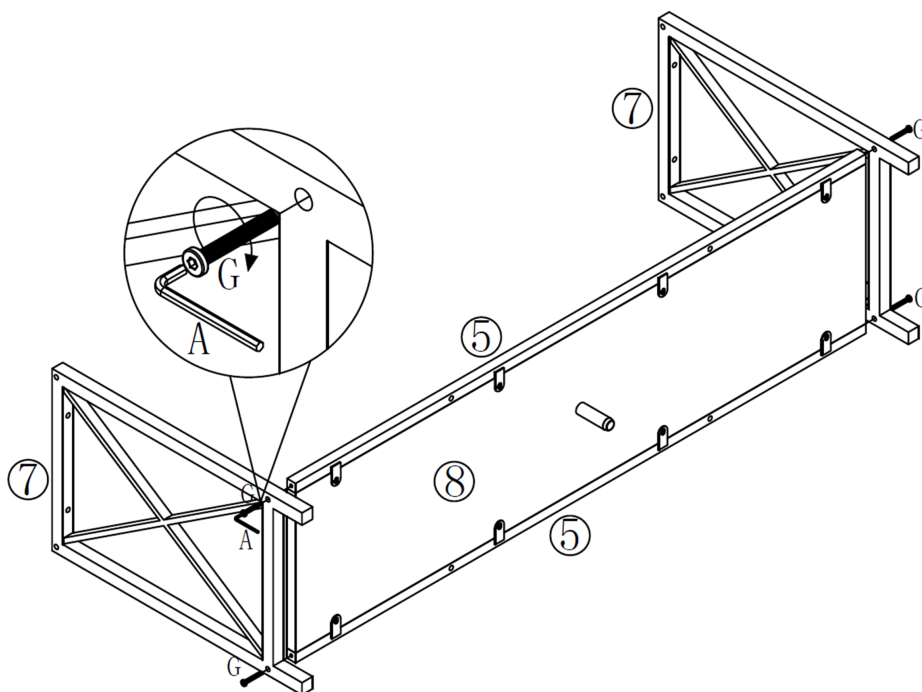

Step 05

- ✚ Connect and fasten 2 Metal Legs(④) to Mid Panel(③) with Screws(D) by Allen Key(A). Tighten all screws after all holes are aligned.

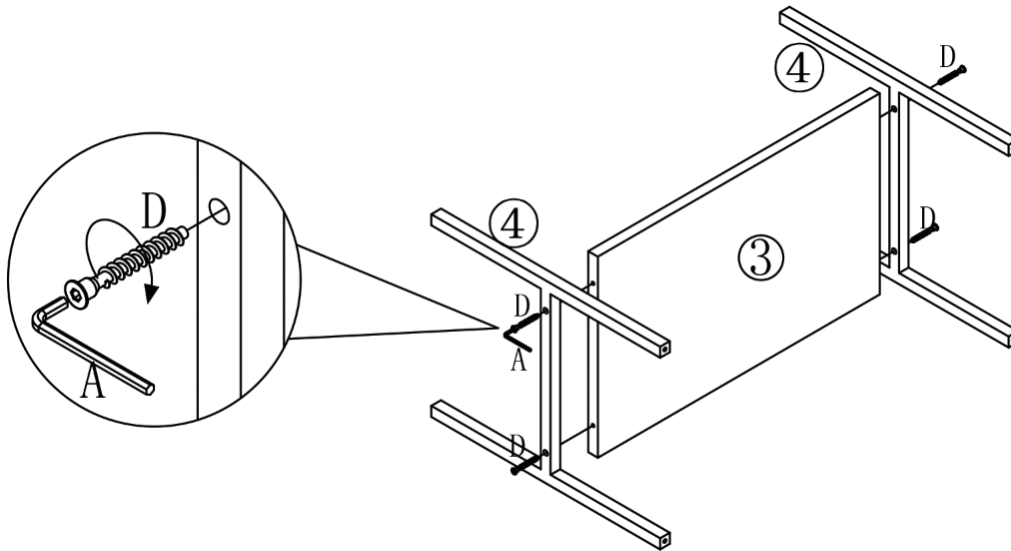

Step 06

NOTE: If holes don't align, loosen all bolts and adjust the holes slightly. After all holes are aligned, tighten all bolts.

- ✚ Attach and align Metal Legs(④) to Metal Tubes(⑤) as shown with Medium Bolts(B) by Allen Key(A). Tighten all screws after all holes are aligned.

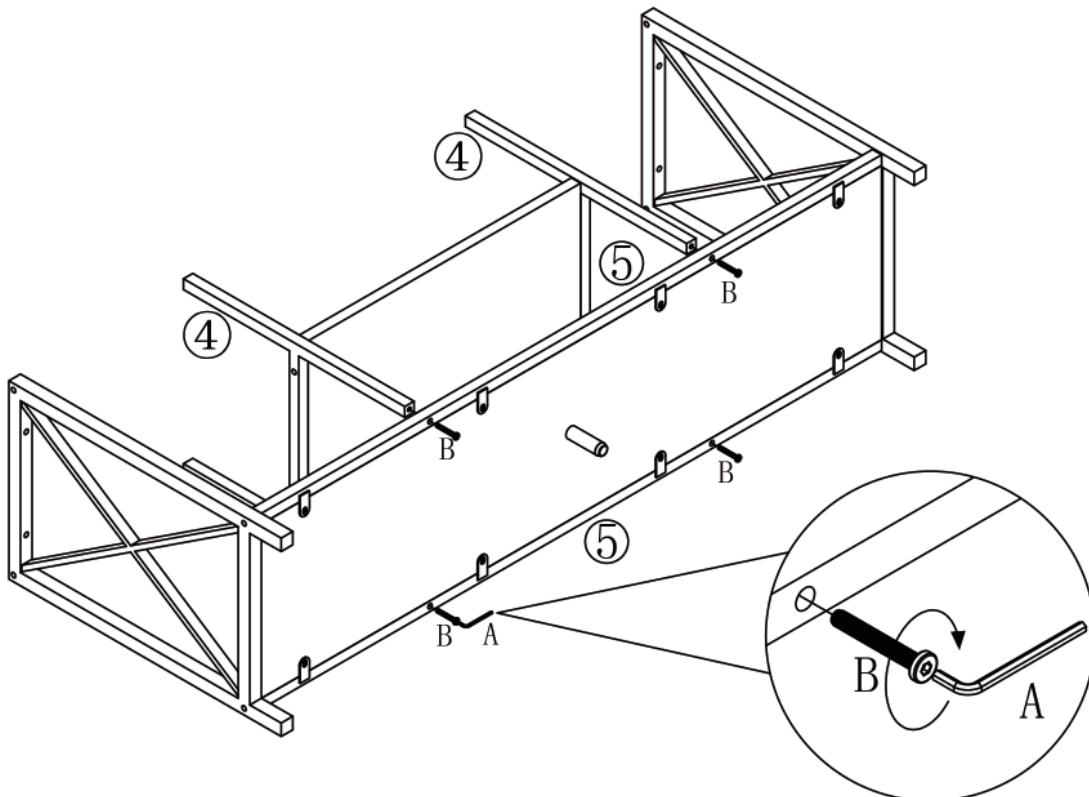

Step 07

NOTE: DO NOT fully tighten all bolts at this step

- Put TV Stand right way up on a clean smooth surface such as carpet or cardboard. Connect and fasten 2 Metal Rods(⑥) to 2 Metal Frames(⑦) with Long Bolts(G) by Allen Key(A). Don't fully tighten all bolts at this step.

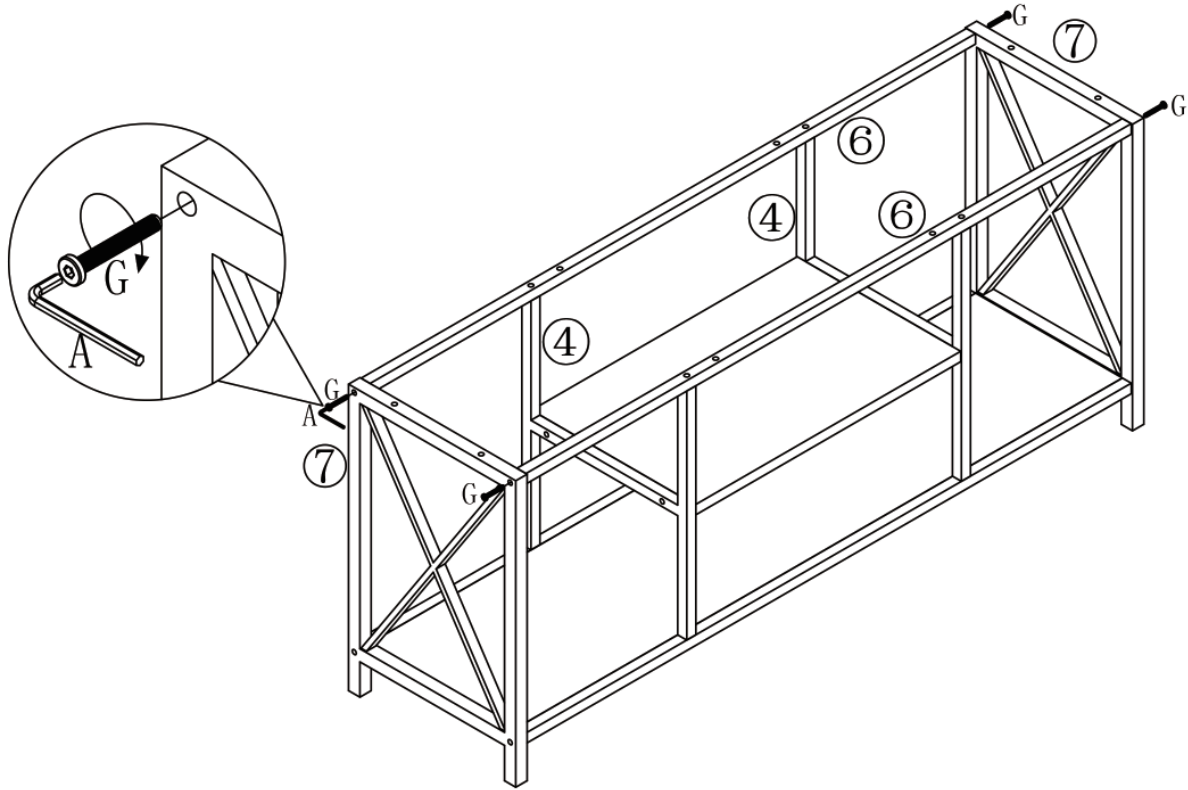

Step 08

NOTE: If holes don't align, loosen all bolts and adjust the holes slightly. After all holes are aligned, tighten all bolts.

- Screw 4 Medium Bolts(B) to 2 Metal Rods(⑥) by Allen Key(A). Tighten all bolts after all holes are aligned.

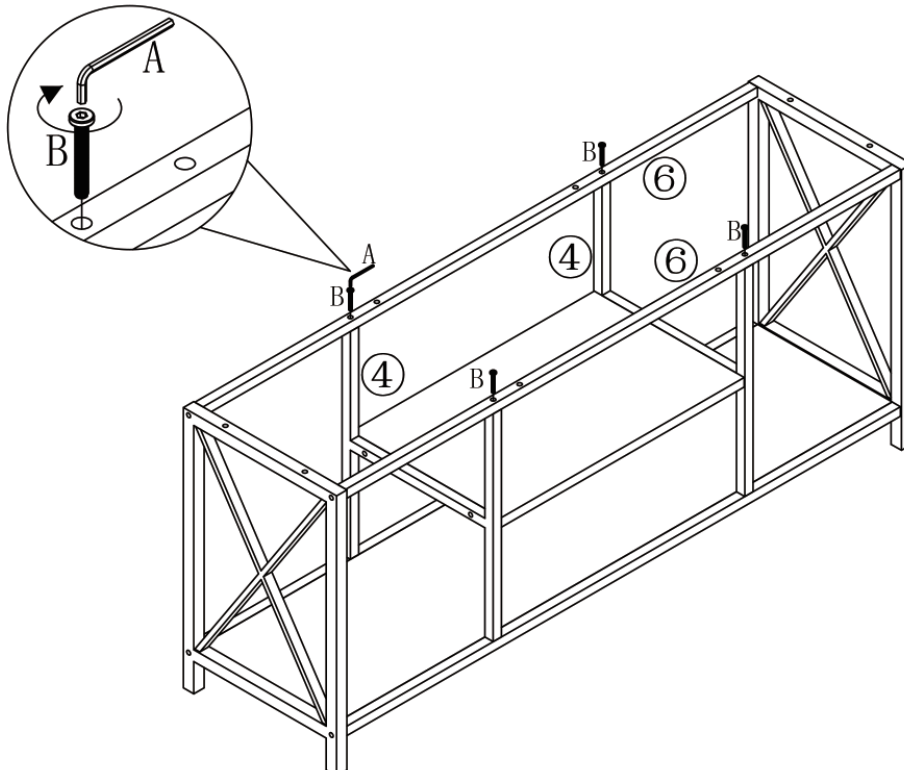

Step 09

NOTE: If holes don't align, loosen all bolts and adjust the holes slightly. After all holes are aligned, tighten all bolts.

🔧 Attach and align Top Panel(①) to the assembled frame with Medium Bolts(B) by Allen Key(A).

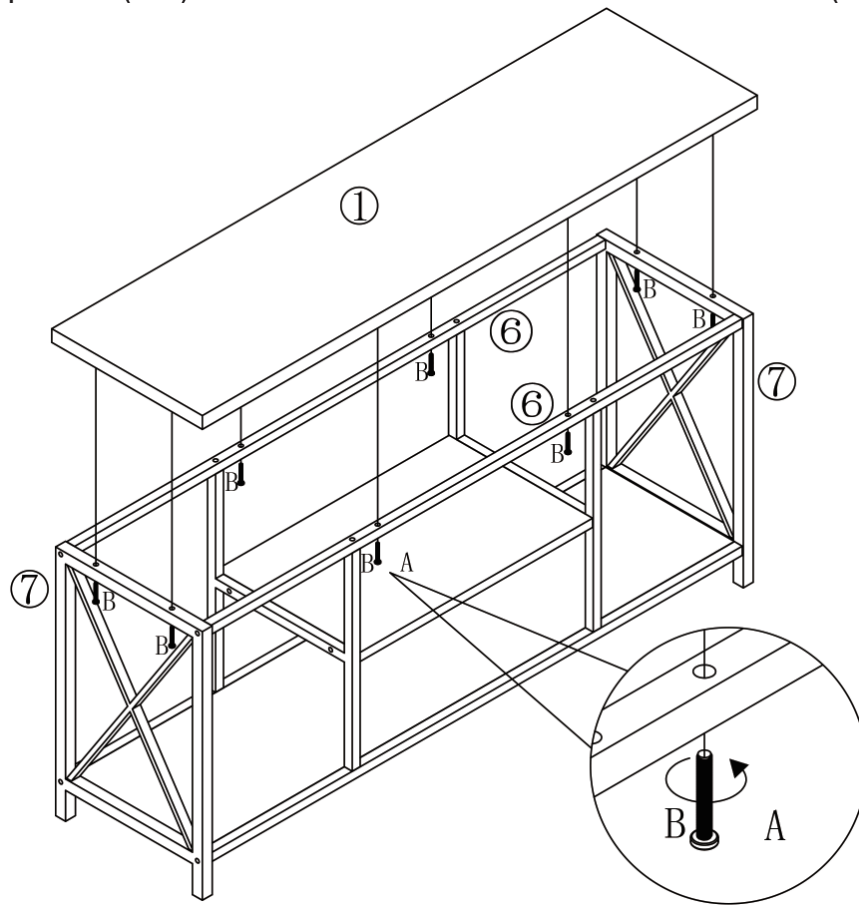

Step 10

🔧 Fully tighten all bolts. And this completes assembly.

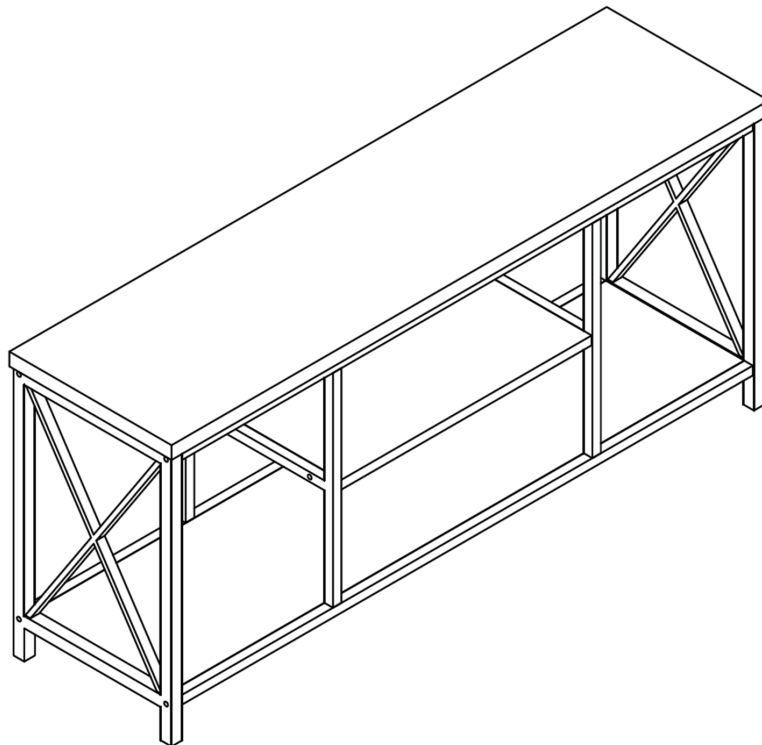

ASSEMBLY TIPS

1. Please read the assembly instructions first and become familiar with the parts.
2. Proper assembly of this item requires 2 people.

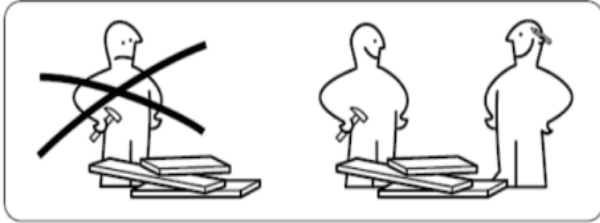

3. Unpack and assemble this unit in an spacious area, assemble the unit on top of the empty carton or carpet to prevent scratches.

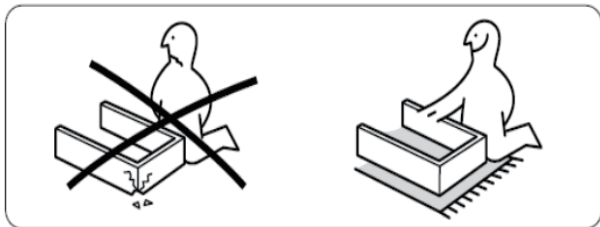

4. To avoid accidentally discarding small parts or hardware, DO NOT dispose of any contents until assembly is completed.
5. **Do not fully tighten all bolts until all parts are in place.** Failure to follow these instructions may cause the bolts to misalign during assembly.

CARE INSTRUCTIONS

- (1) Hardware may loosen overtime. Periodically check that all connections are tight.
- (2) Wipe with a soft, dry cloth. To protect finish, avoid the use of chemicals and household cleaners.
- (3) All hot serving dishes should be placed on a pad.
- (4) Any liquid spilled onto the furniture should be cleaned up immediately with a dry cloth.