

Assembly Instructions

Caution: Please read this carefully before you proceed

Please look in the velcro pouch for hardware packs and legs.

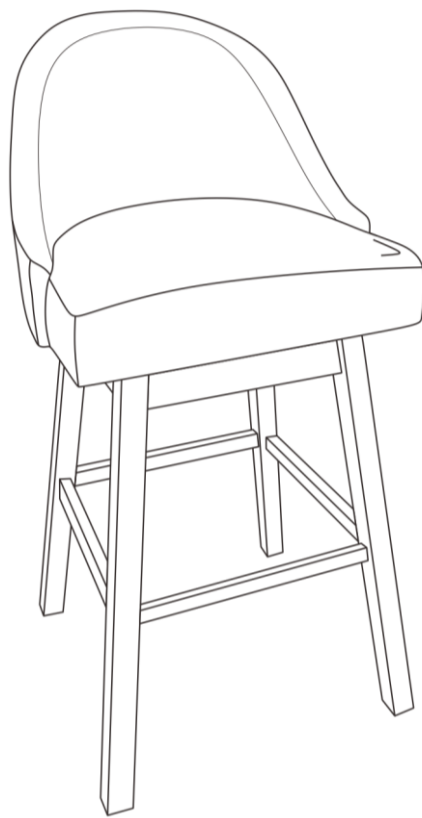





Bar Chair



Part List

Label	Picture	Description	QTY
A	A line drawing of the chair seat, showing its rectangular shape and curved backrest.	Chair Seat	1
B	A line drawing of a single chair leg, showing its rectangular cross-section and a small hole near the top.	Chair Leg	4
C	A line drawing of a side rail, showing its rectangular cross-section and a small hole near the top.	Side Rail	4





Hardware

Label	Picture	Description	QTY
①		Bolt (M6x50mm)	9
②		Screw (M4x38mm)	9
③		Spring Washer	9
④		Washer	9
⑤		Allen Key	1
⑥		Screwdriver (Not provided)	1

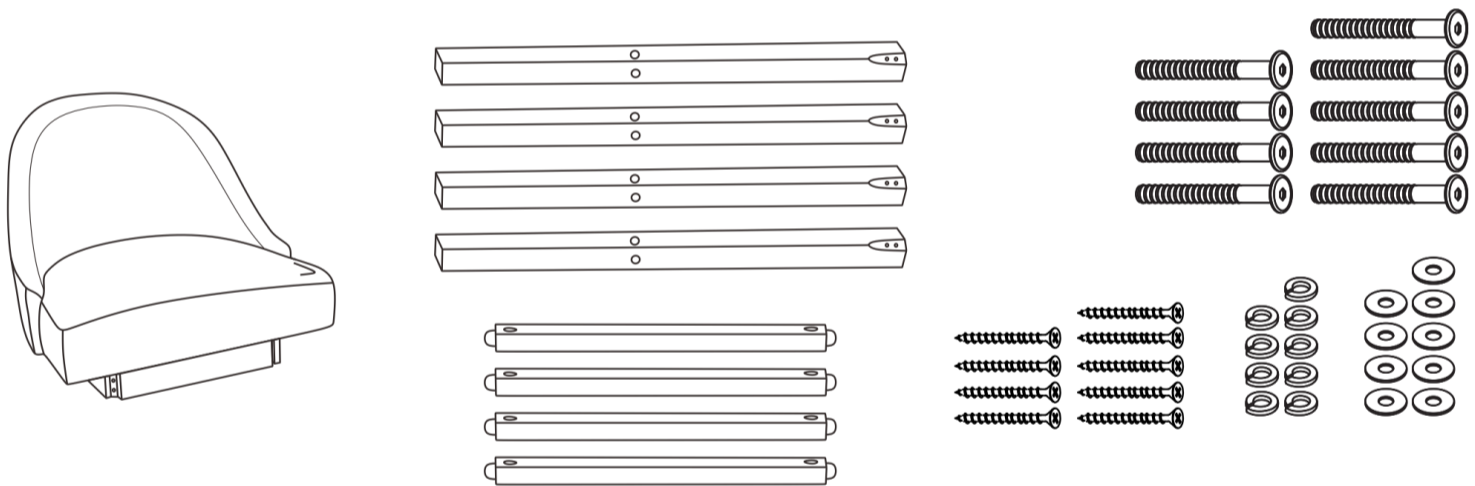
Assembly Preparation

Before Beginning Assembly:



-  • Read instructions, cover to cover-
-  • Have 2 adults on hand for assembly-
-  • Do not assemble on flooring or carpet-
-  • Assemble on a clean non-marring surface (packing foam)-
-  • Save all packaging until finished-

Assembly Steps

Overview

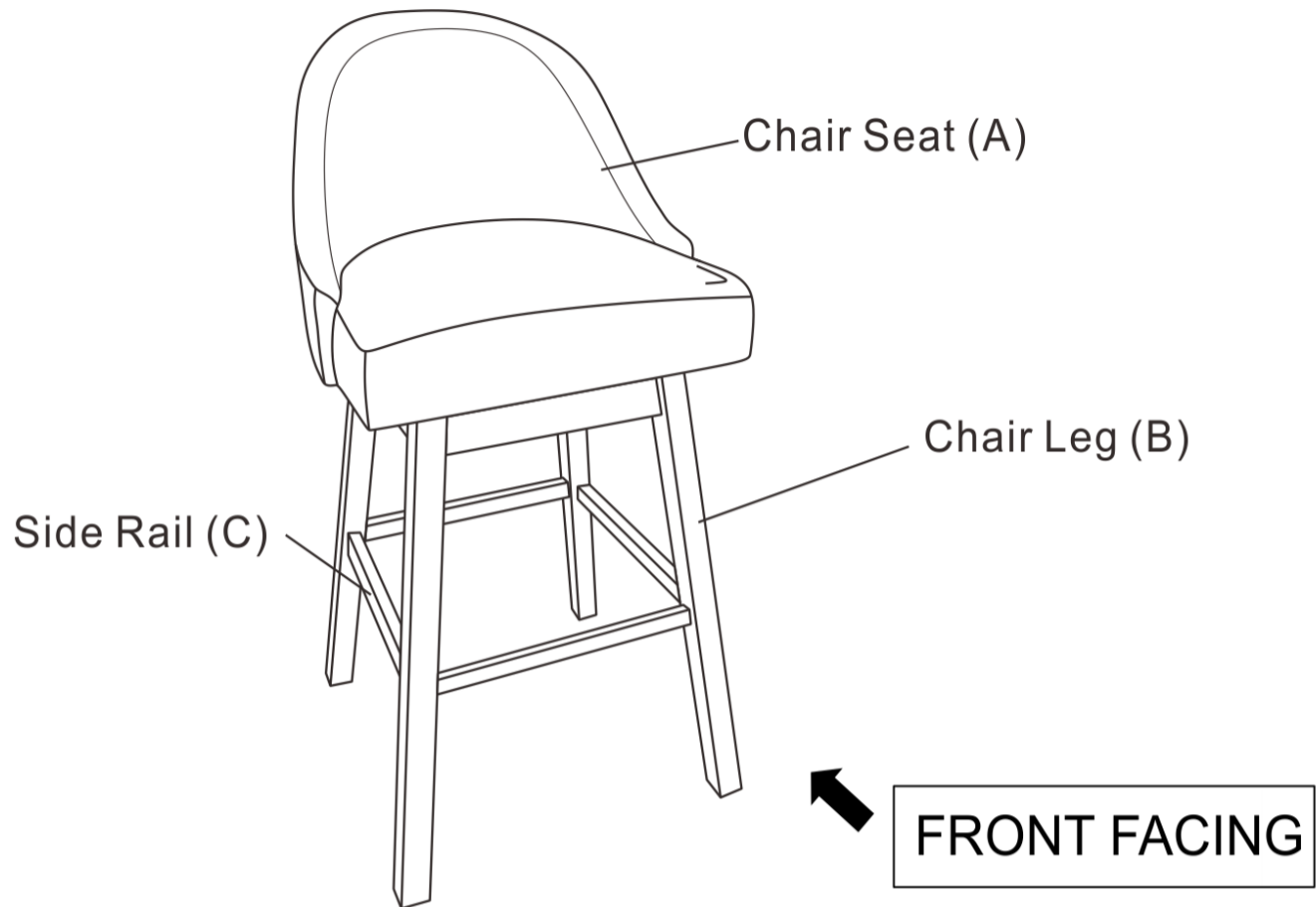

This Bar Chair has multiple parts and may require up to 30 minutes to assemble. To give you an overview of the Stool parts, the above picture is provided to help you put the various parts into perspective. Please read through the instructions below to familiarise yourself with the parts and steps before assembly.

Step 1

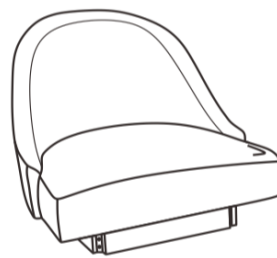

A. Chair Seat

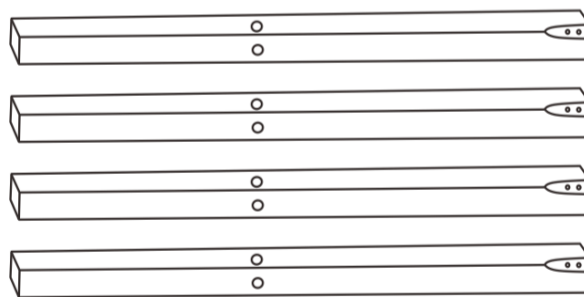

B. Chair Leg

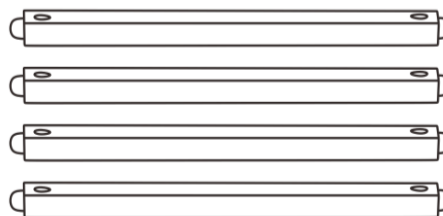

C. Side Rail

Place the Chair Seat(A), Chair Legs(B) and Side Rail(C) onto a clean, non-marring surface.

Step 2

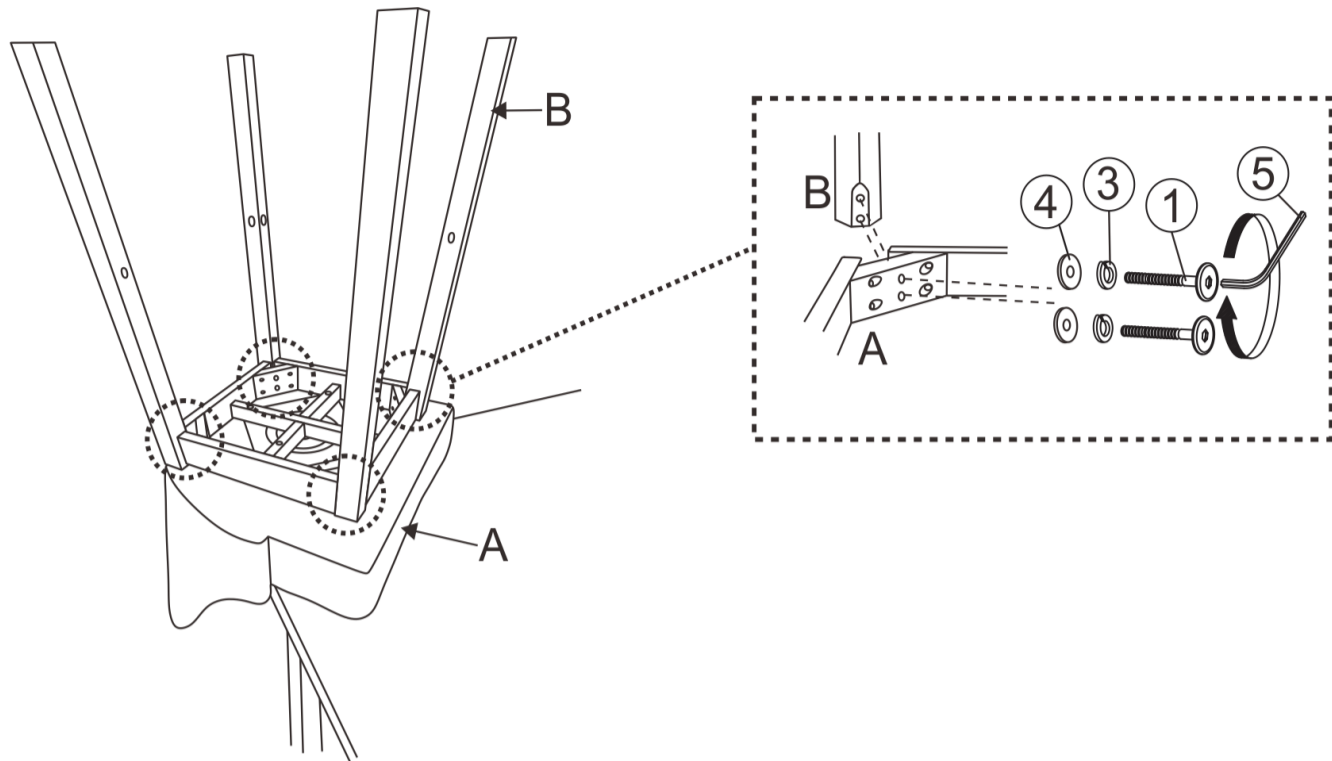

Place the Chair Seat (A) on the edge of a table as shown in picture.
Attach Chair Legs(B) to Chair Seat(A) with Allen Key(5), using Bolts(1), Spring Washers(3) and Washers(4).

Do not fully tighten the bolts.

Step 3

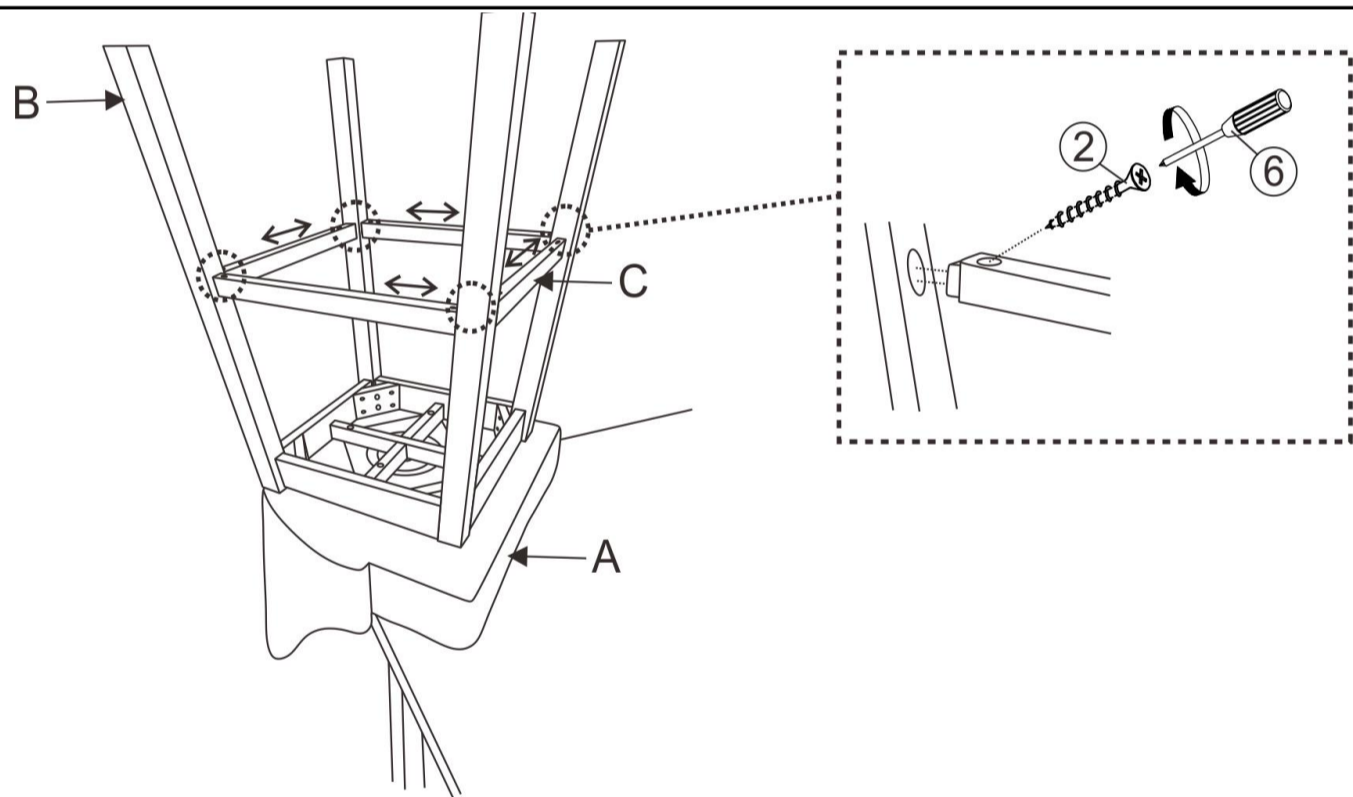

Insert Side Rail(C) into mounting positions between the legs in sequence.
Attach Side Rail(C) using Screws(2) and Screwdriver(6).
Note: You may need to apply a little pressure to Chair Leg to enable the Side Rail to be slotted into position.

Step 4

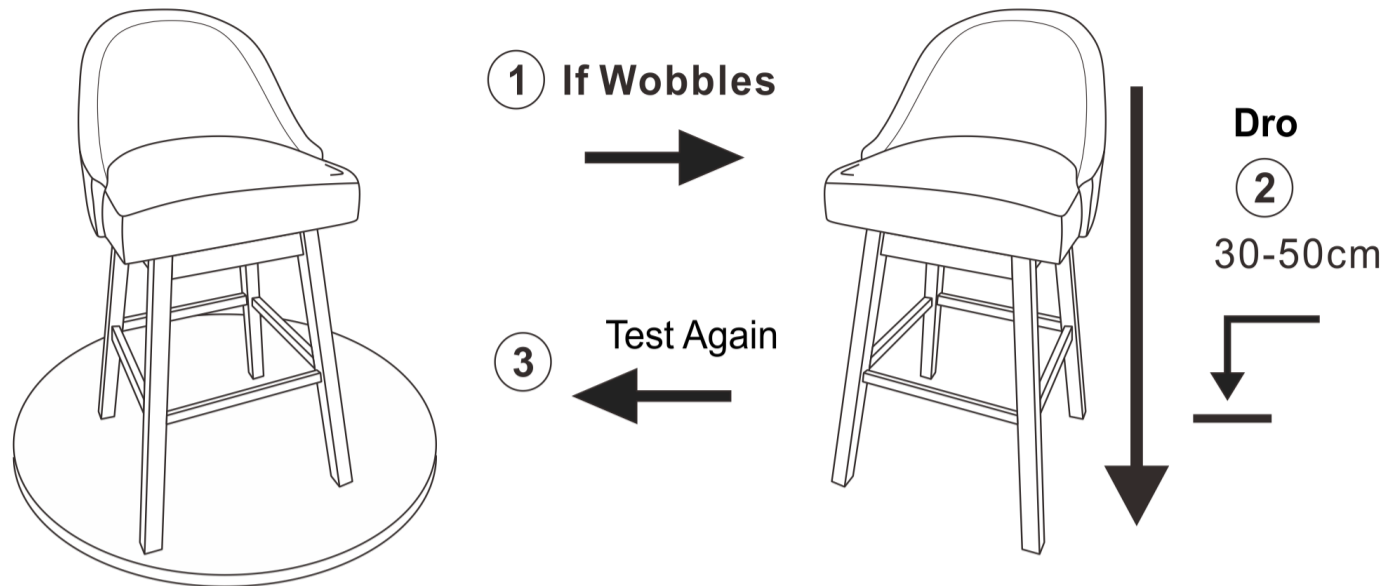

Place the Bar Chair on a Level Surface to check if it wobbles.

If it wobbles, lift the Bar Stool up some 30cm to 50cm from the ground, keep your feet and toes well away from the drop zone, and drop the Bar Chair freely and vertically with the four legs, hitting the ground at the same time.

This Drop Test will help ensure that all parts and gaps reach full alignment. Test again for evenness on a Level Surface.

If no wobbles are found, proceed to tighten all the Bolts.

When tightening the Bolts, tighten sequentially.

Do not tighten any Bolt fully and then move on to the next one, as this could cause the frame to warp. Rather in a sequential manner, gradually tighten each Bolt until all are evenly secured. This methodology will ensure maximum evenness once all Bolts are fully tightened.

If the chair still wobbles, loosen the Bolts and execute the same drop test, then proceed to tighten the bolts again in a sequential manner.



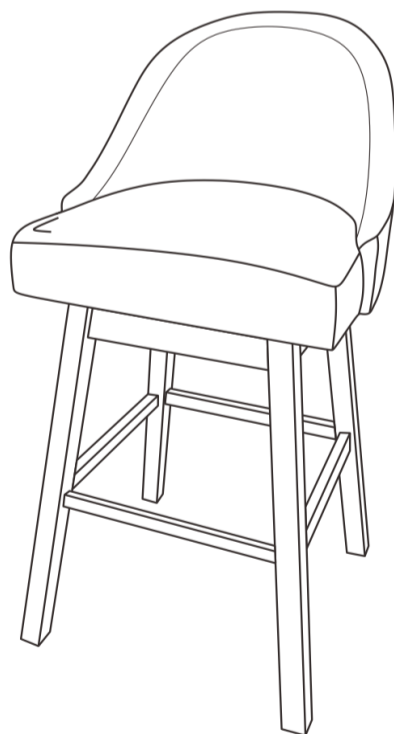

















Step 5



Your Bar Chair is now ready for use.

This Bar Chair can only be used on a flat, level surface.

Care & Maintenance

-   ● Do not put hot items directly on furniture surface
 -   ● Do not clean furniture with harsh cleansers or polish.
 -   ● Do not place furniture under direct sunlight.
 -   ● Do not place furniture near heating or cooling vents.
 -   ● Do not write on furniture without a padded barrier to protect the surface.
 -   ● Do not place furniture outside . For indoor use only .
 -   ● Not for commercial use. For residential use only .
 -   ● Stains may be removed with mild soap solution and damp cloth.
 -   ● Children should not climb or jump on the furniture.
-
-   ● Dust and pick-up spills using a clean, non-colored, lint-free cloth .