

2 Door Sideboard

# OWNER MANUAL

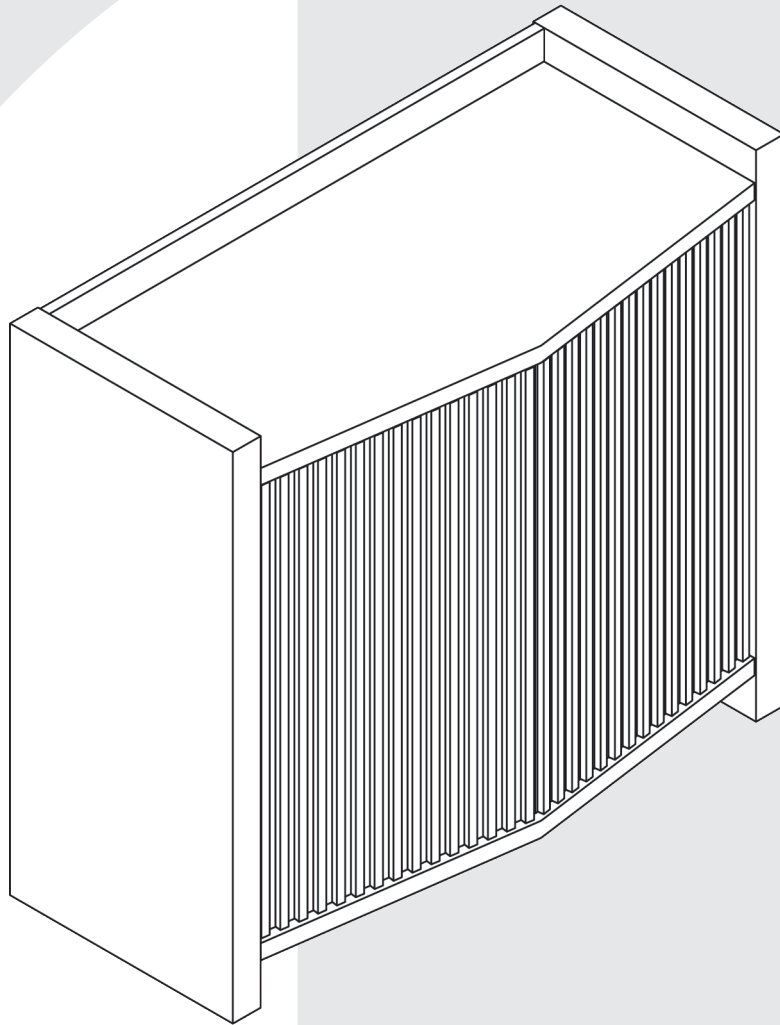

Instruction  
Manual

## Read Before Assembly

The instruction booklet contains **IMPORTANT** safety information. Please read it in full and keep it for future reference.



### WARNING!

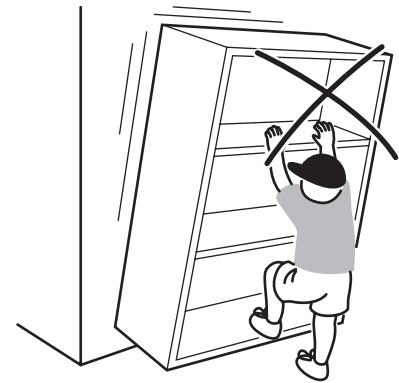
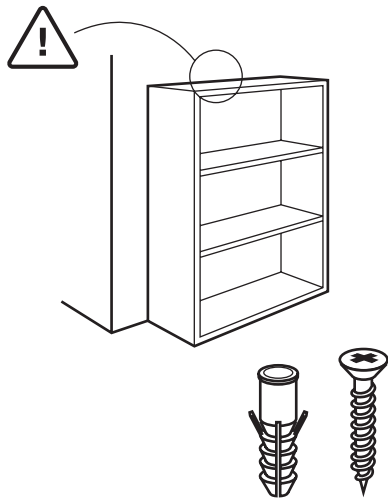

- Serious or fatal crushing injuries may occur if the furniture tip-over. Furniture must permanently affixed to the wall with anti-tipping device(s) in order to prevent the furniture from tipping over.
- Different wall materials requires different type of wall anchors or screws. Use a suitable wall anchors or screws for your specific wall in order to secure the stability and load bearing capacity of the furniture. If you are uncertain about which type of device to use, please contact us or local hardware store and seek professional advice.
- Only place items that is within the recommended size and weight limit of the furniture.
- Items placed onto the furniture must be resting on a support surface without hanging over the edges.
- Climbing on, stepping on, or placing overweighted objects on the product may cause property damage and / or injuries.



## CAUTION!

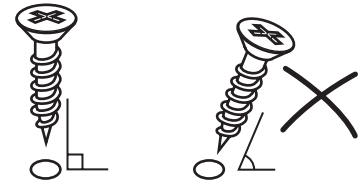
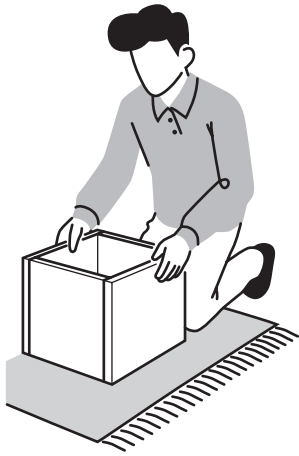

- Assemble the furniture on an empty carton, carpet, or rug to prevent scratches or damage.
- When assembling the furniture, keep pets and children away from the assembly area.
- Ensure the product is fully assembled before use. If you are missing any hardware or parts, do not use it until you have restored the missing parts.
- This furniture requires 2 people for assembly.
- Lay out all components and hardware separately on a flat surface and make sure that no parts are missing or damaged before assembly. Do not destroy or discard any packaging until you are certain that you have all the necessary parts for assembly.
- There are small components used in the construction of the furnitures. Loose items, plastic bags, and packaging films should be kept away from pets or children to avoid choking hazard or suffocations.
- Read this instruction manual prior to assembly and familiarize yourself with the various steps.
- Install all hardware perpendicular to the opening unless otherwise specified.
- Hand tight all hardware and careful not to over-tighten to avoid damaging the product.

## Assembly Symbols



- Follow sequential order.



- Build specified number of parts.



- Flip part as indicated.



- Rotate part as indicated.



- Choose your own assembly options.



- Pay attention to the part orientation.



- Leave bolts or screws partially tighten.



- Fully tighten bolts or screws.



- Level the furniture on the ground.



Estimated Time for Assembly

**60 mins**



Weight Capacity Limitations are as Follows:

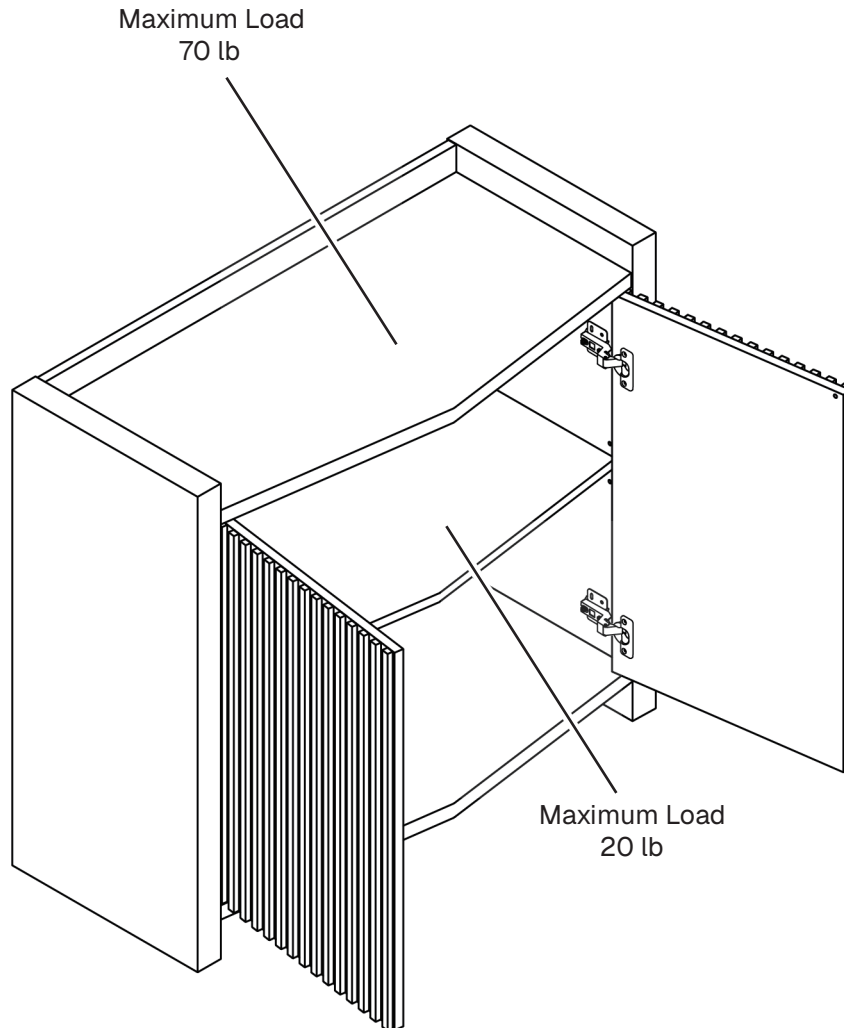

## Tools Needed

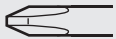
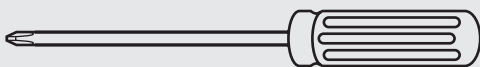

• Philips Screwdriver

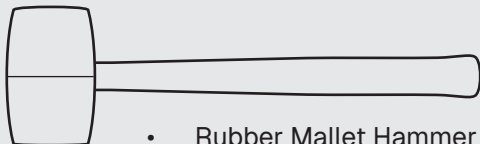

• Rubber Mallet Hammer

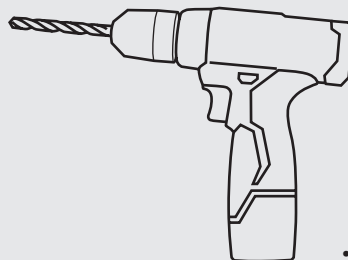

• Electric Drill

# Package Contents

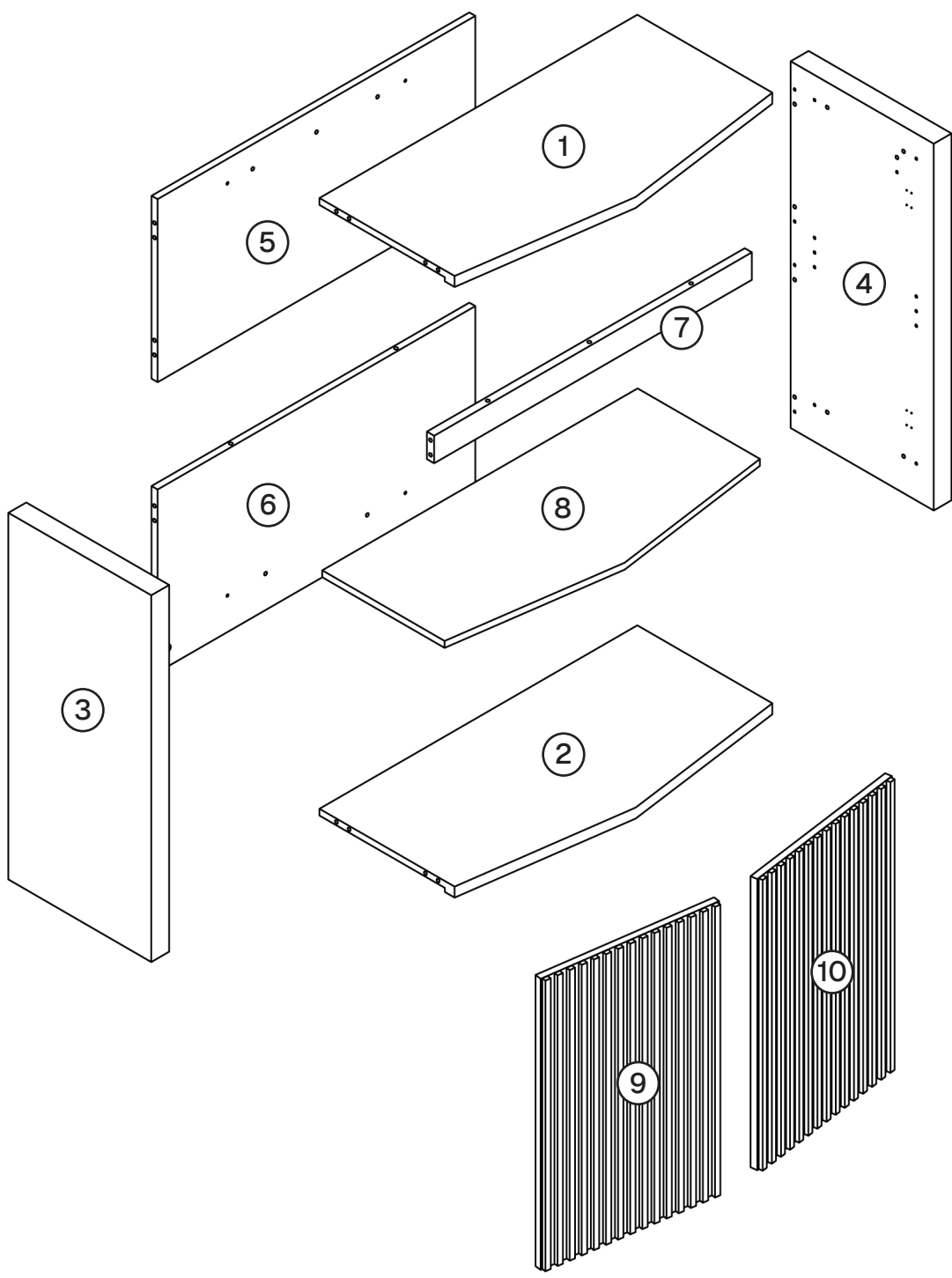

# Package Contents

CODE	DESCRIPTION	QTY
1	Top Panel	1
2	Bottom Panel	1
3	Left Lateral Panel	1
4	Right Lateral Panel	1
5	Upper Back Panel	1
6	Bottom Back Panel	1
7	Crossbar	1
8	Storage Shelf Panel	1
9	Left Cabinet Door	1
10	Right Cabinet Door	1

# Package Contents

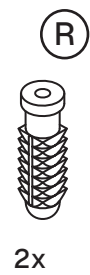
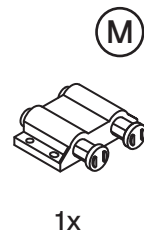
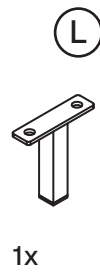
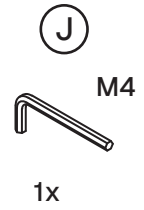
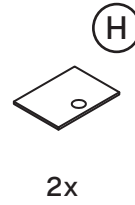
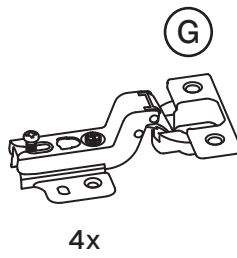
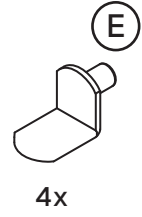
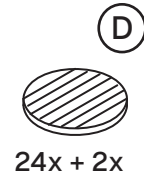
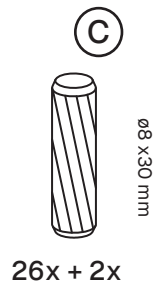
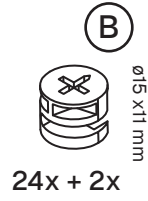
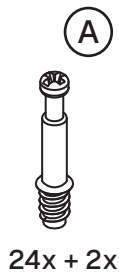

# 01 Back panels

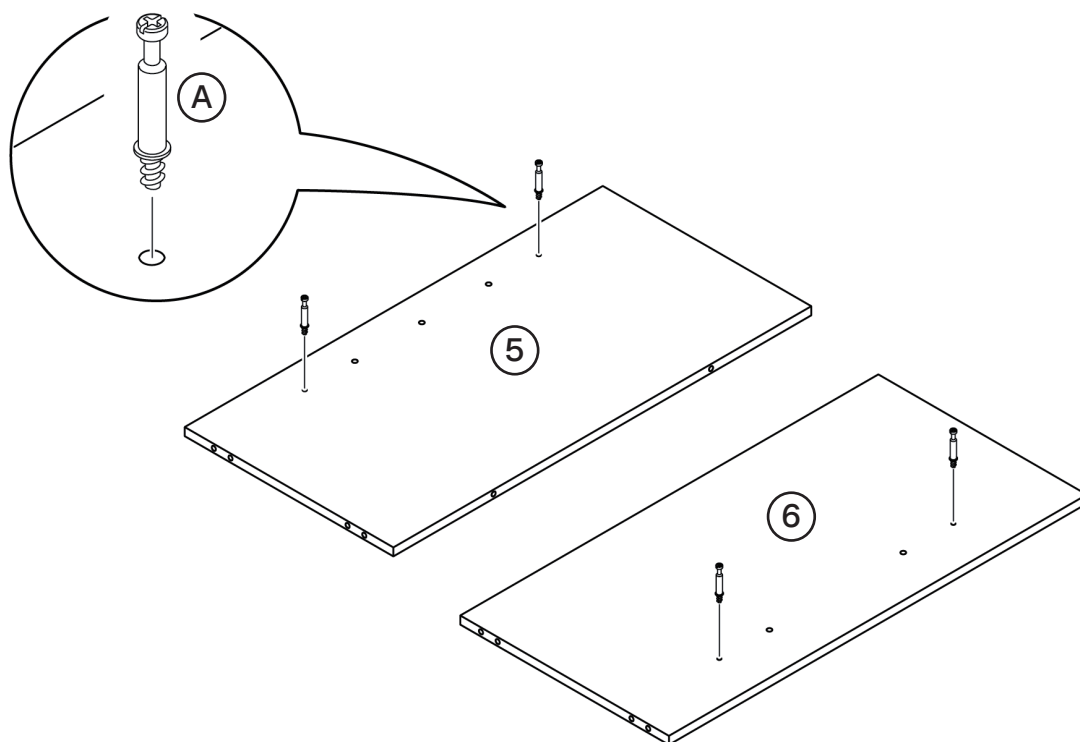
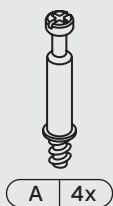

# 02 Back panels

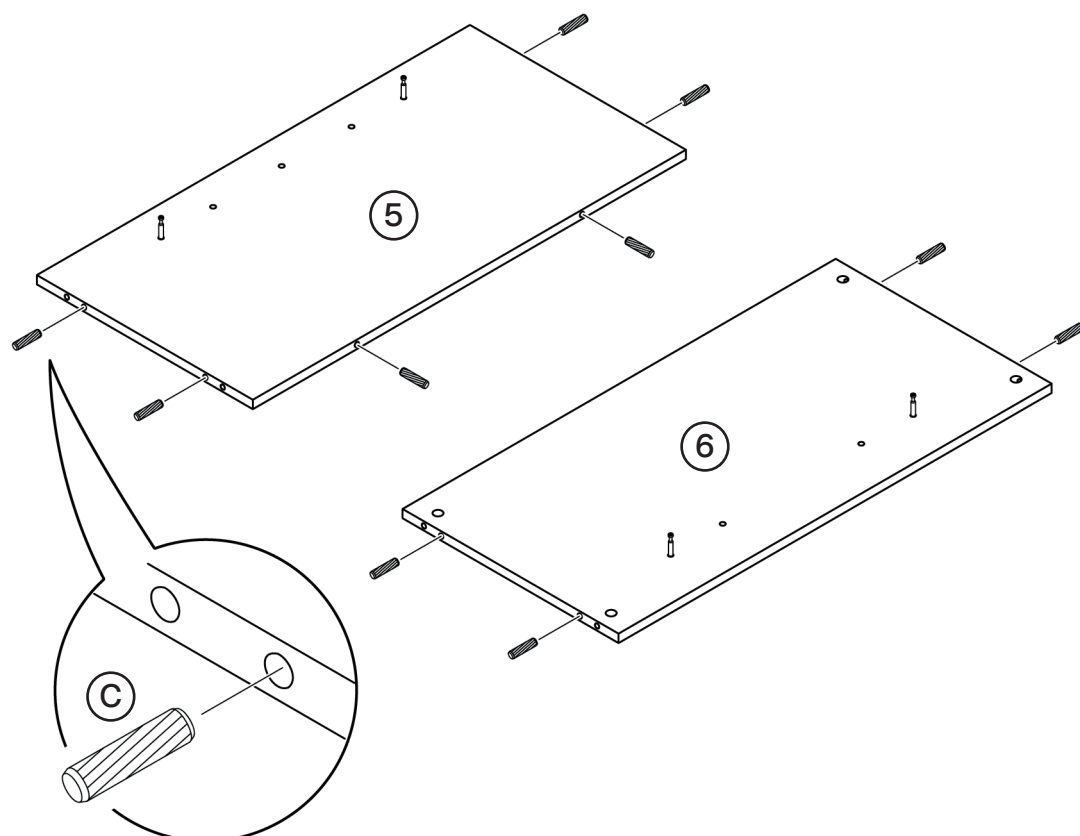
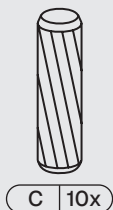

# 03 Top Panel



A 2x

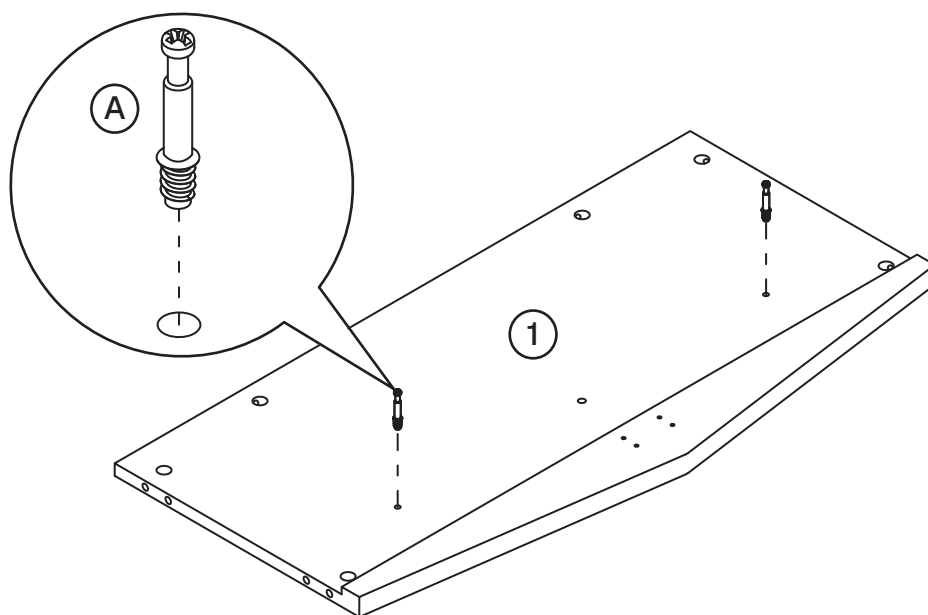

# 04 Attaching magnetic catch on top panel

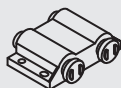

M 1x



ø3.5 x 15 mm

N 4x

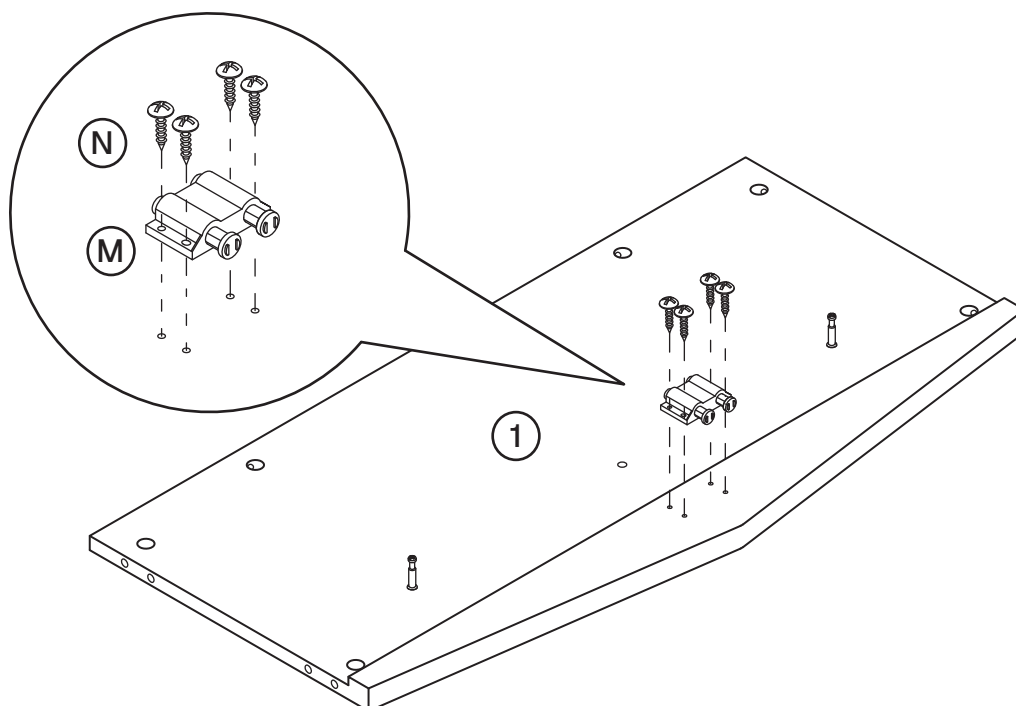

\*Assembly symbols



Pay attention to part orientation

# 05

Top Panel, Bottom Panel, and crossbar



C 16x

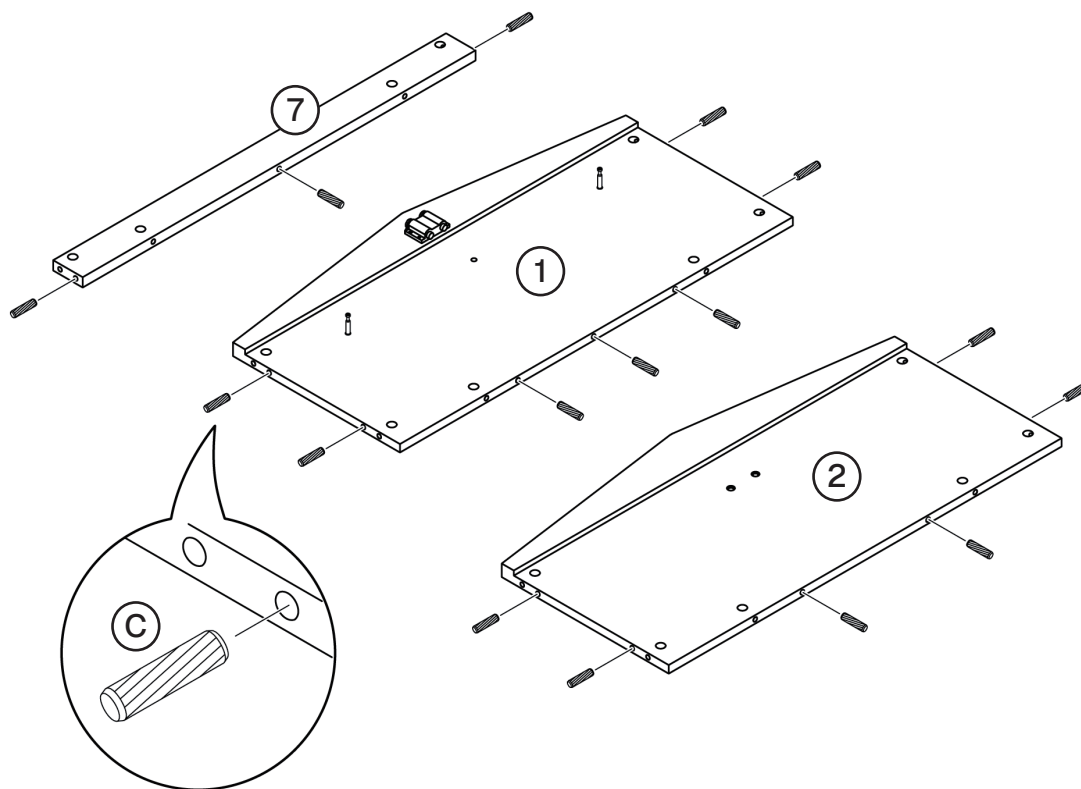

# 06

Assembling crossbar to top panel



B 2x



D 2x

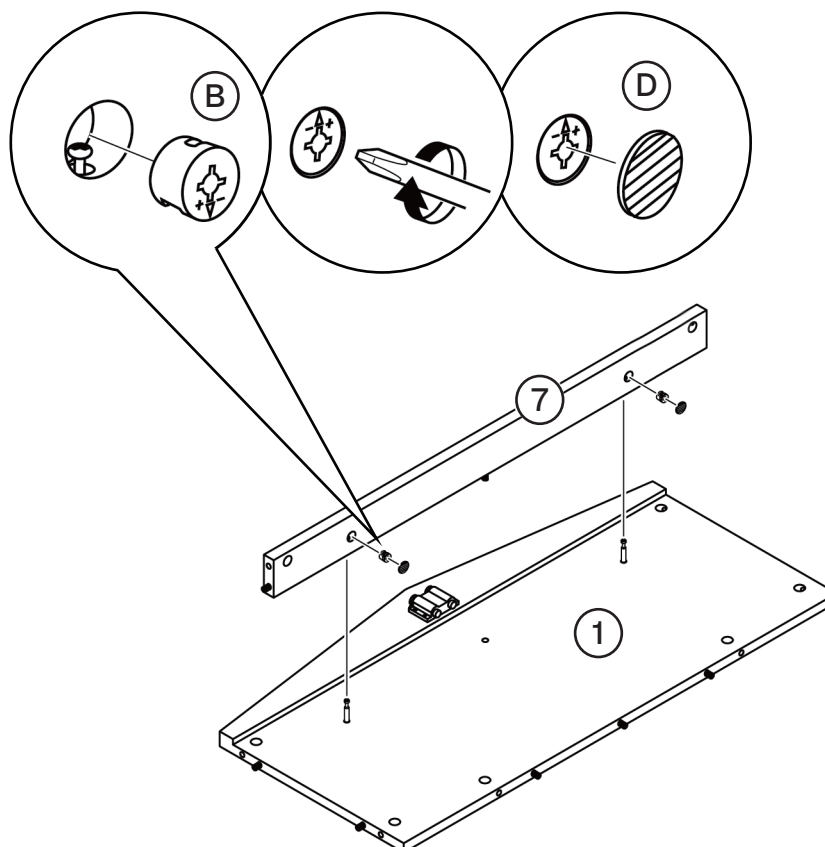

# 07

Assembling top panel and bottom panel to the back panels

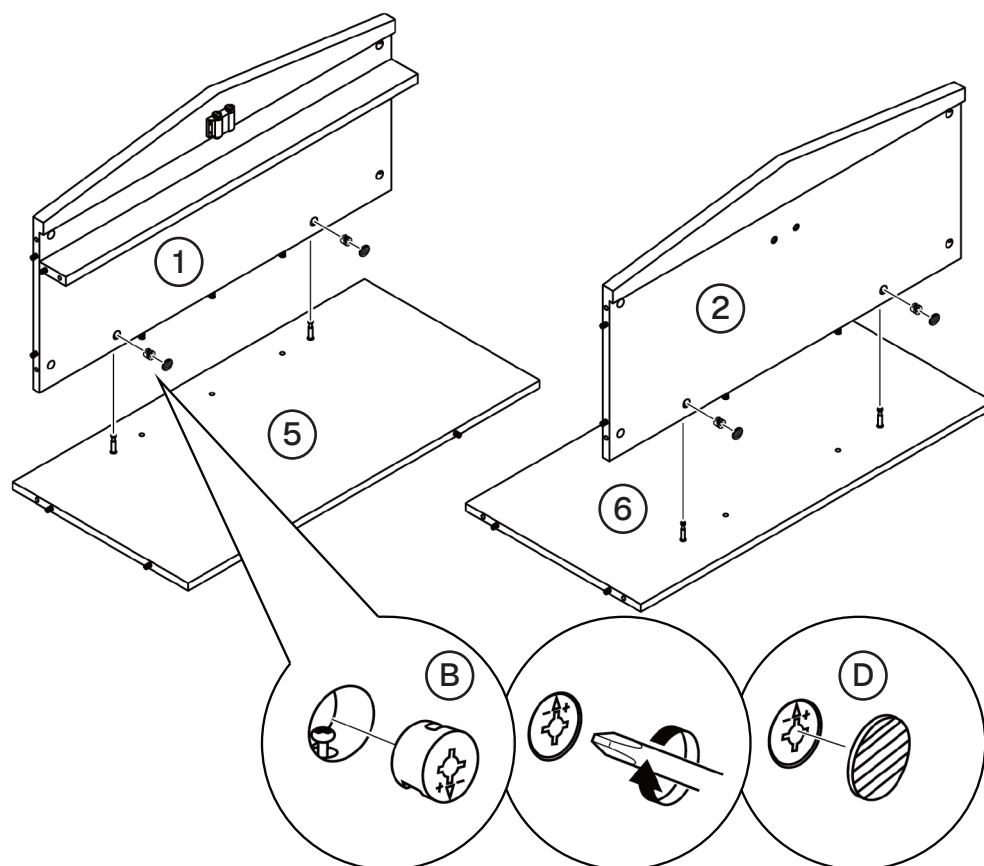
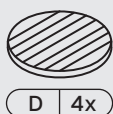

# 08

Connecting the back panels

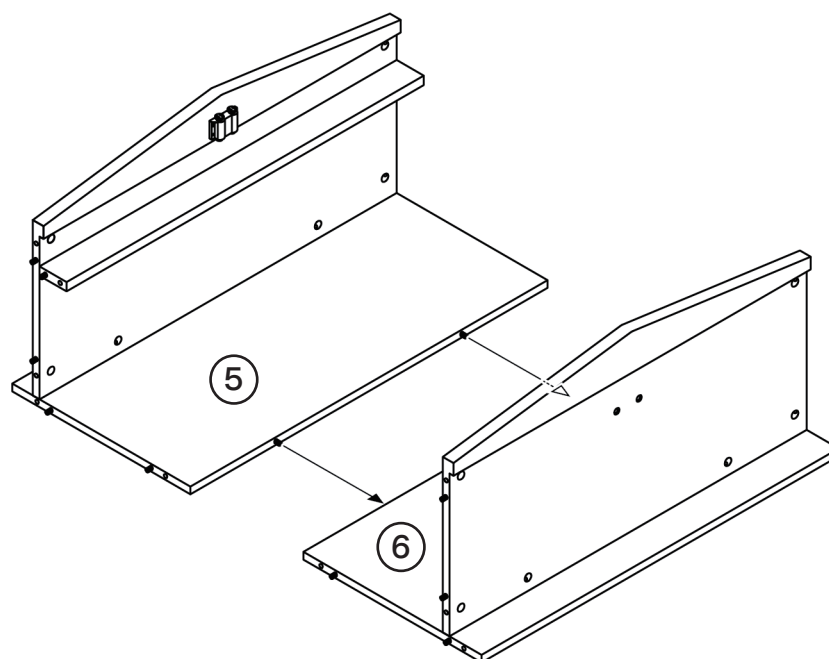

# 09 Lateral panels

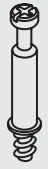

A 18x

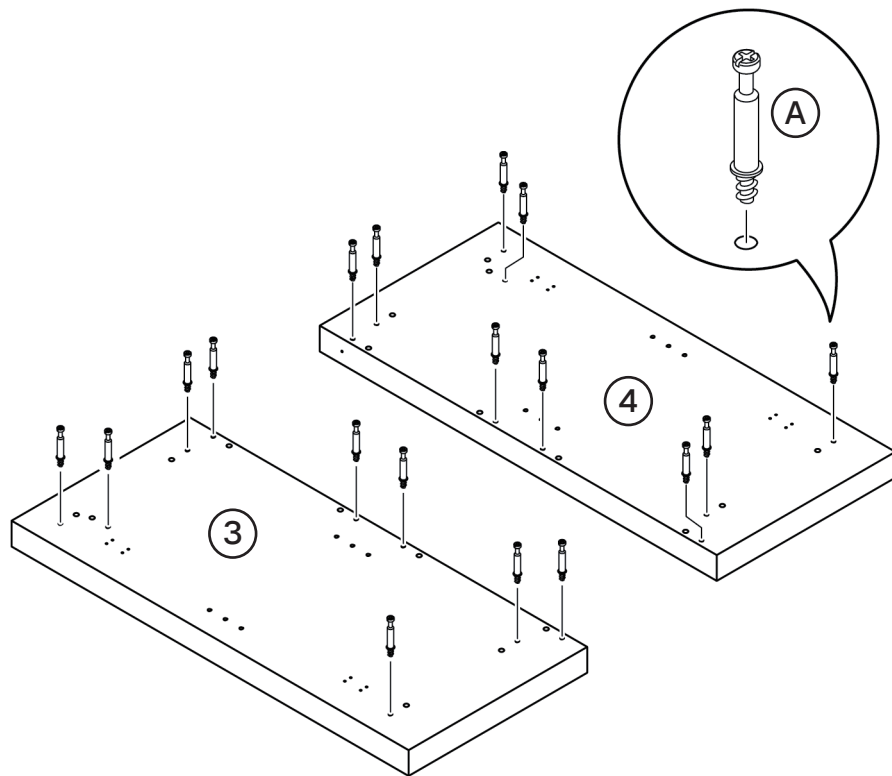

# 10 Attaching the lateral panels



B 10x



D 10x

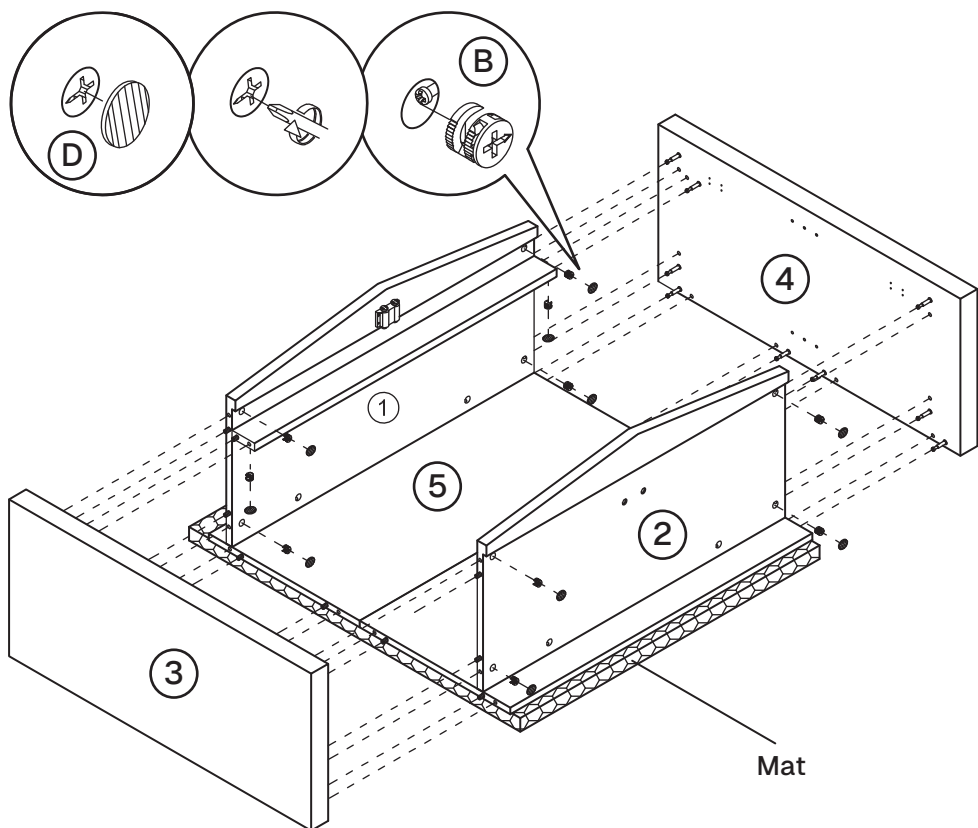

# 11

## Attaching support leg

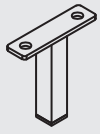

L 1x



M6 x 12 mm

K 2x

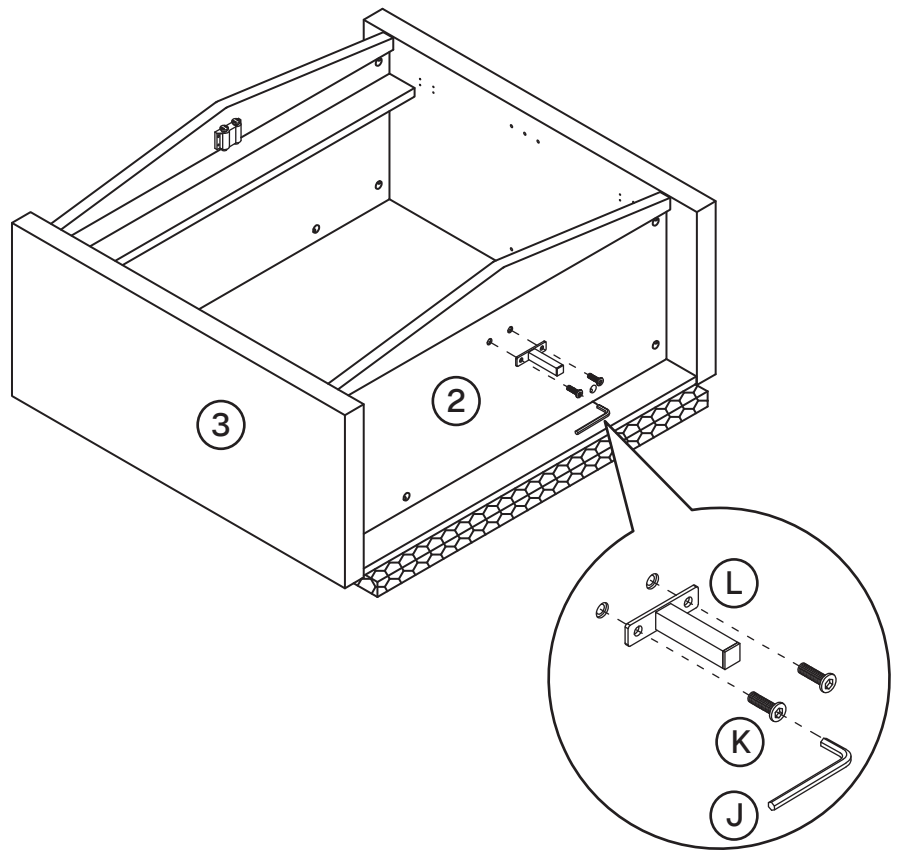

# 12

## Securing back panels



B 8x



D 8x

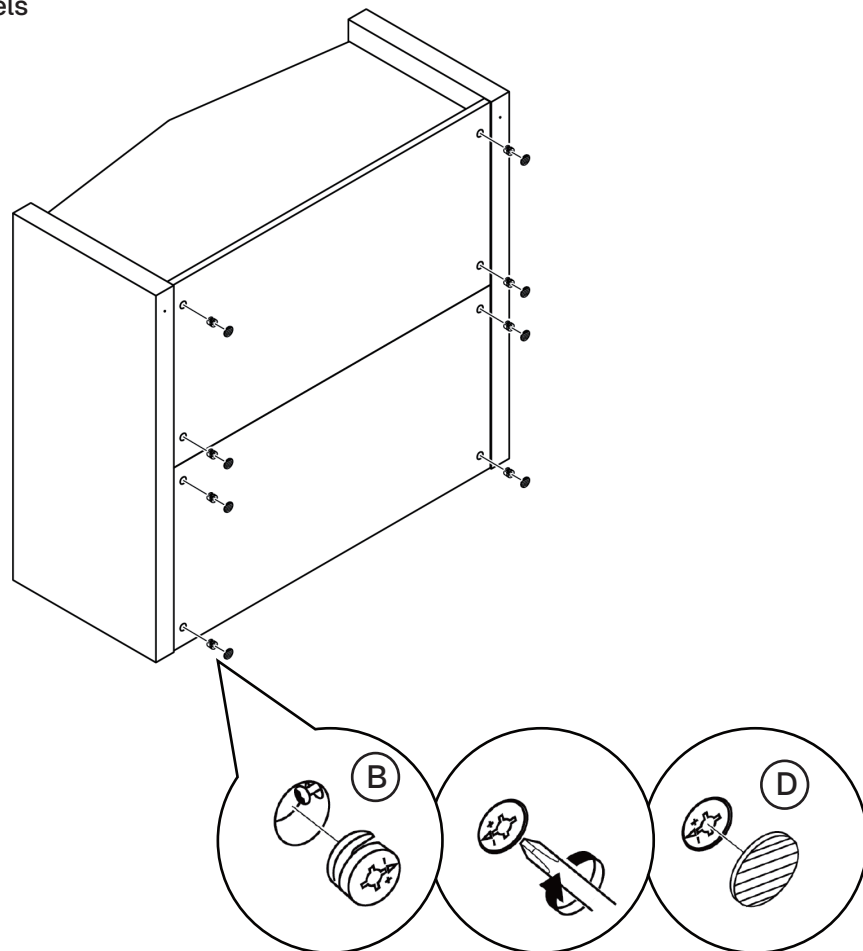

# 13

Attaching shelf pegs and storage shelf panel

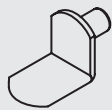

E 4x

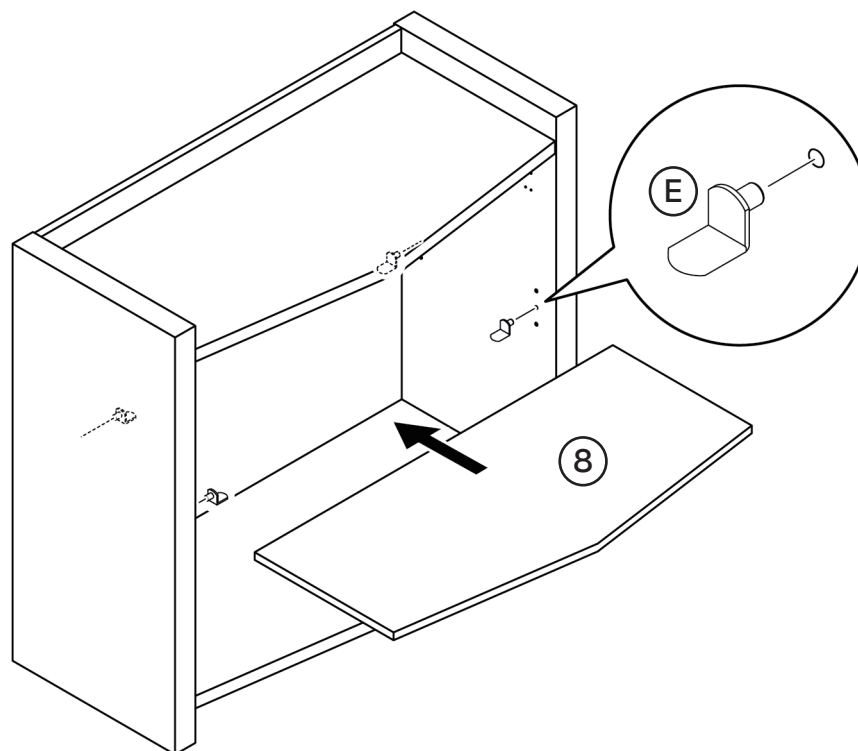

# 14

Attaching catch plates on cabinet doors



H 2x



S 2x

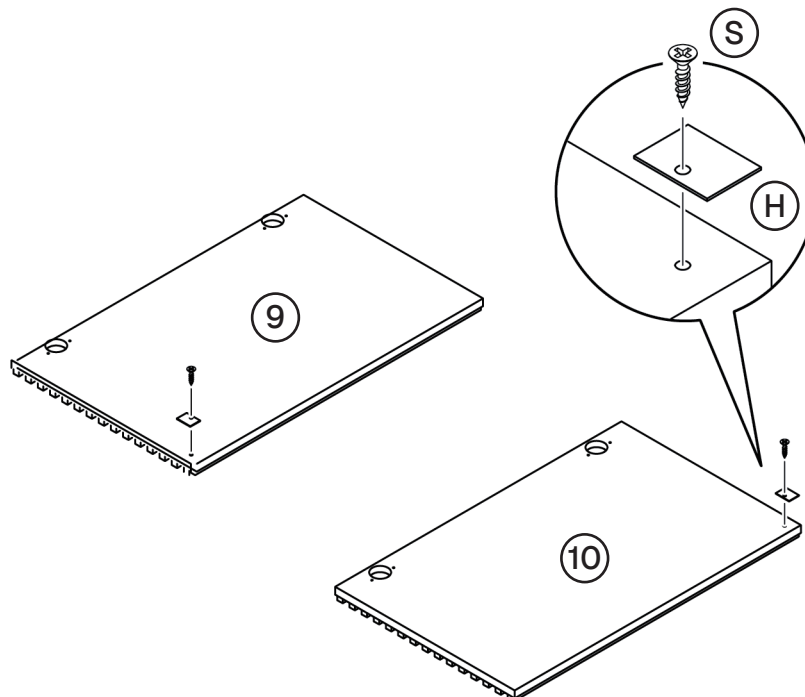

# 15

Attaching door hinges to cabinet doors



F 8x



G 4x

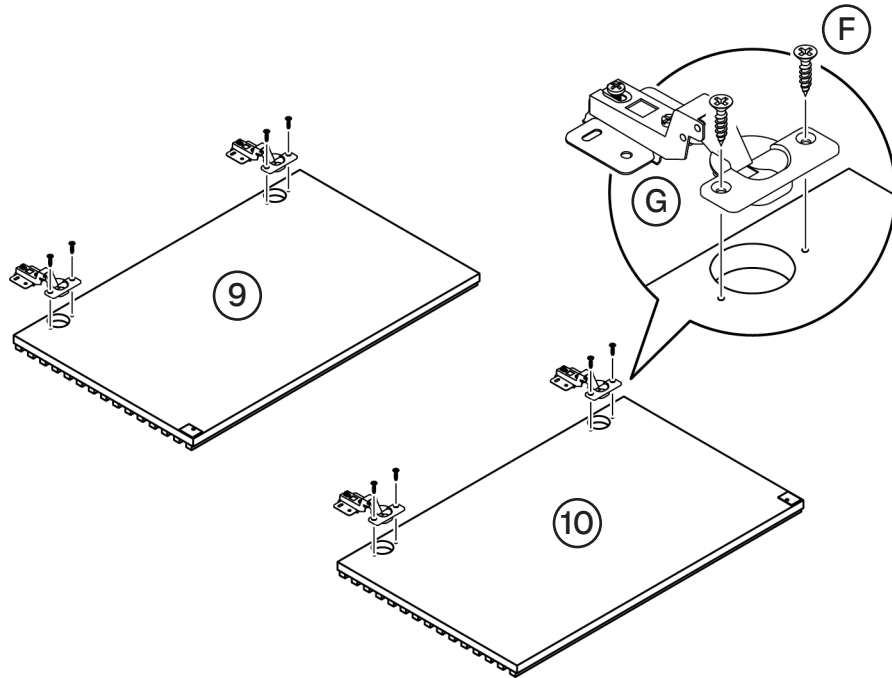

# 16

Attaching cabinet doors



F 16x

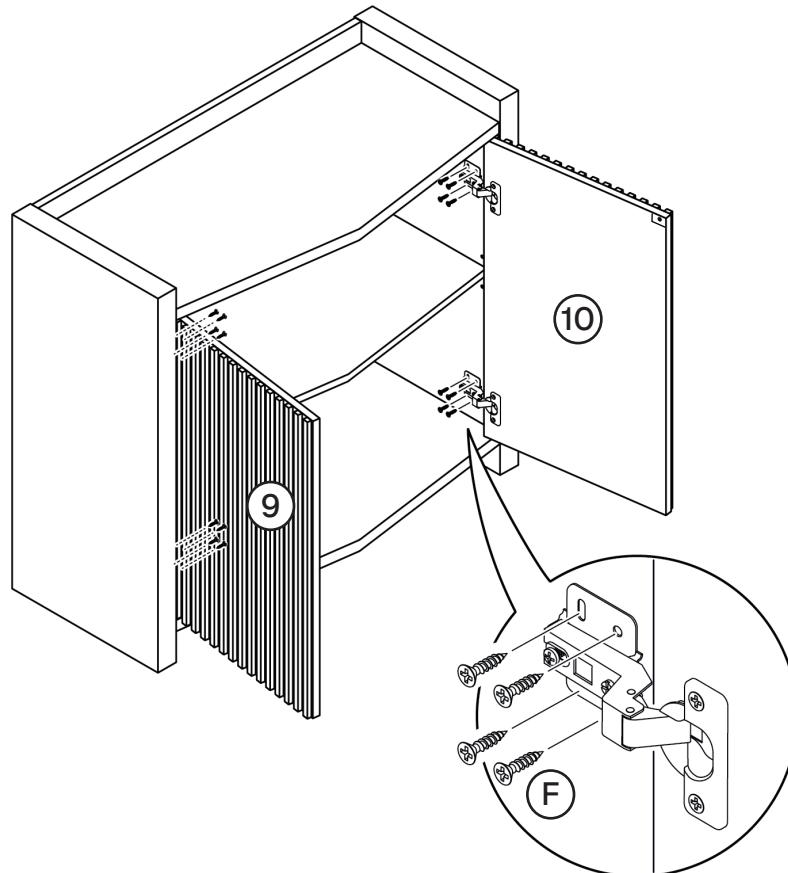

*i*

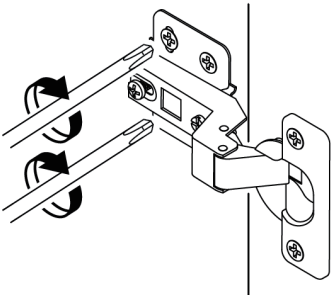
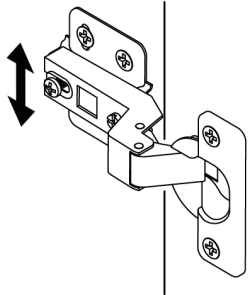
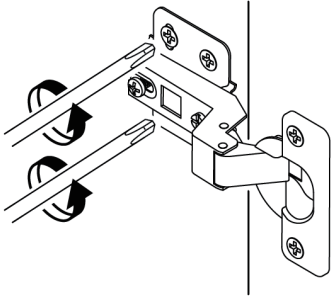
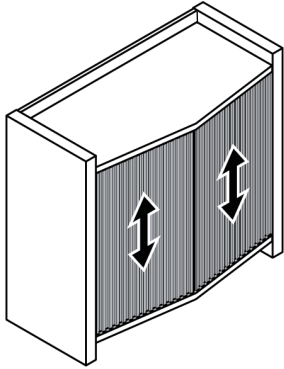

Loosen the screws on the mounting plate to adjust the door **up and down**.

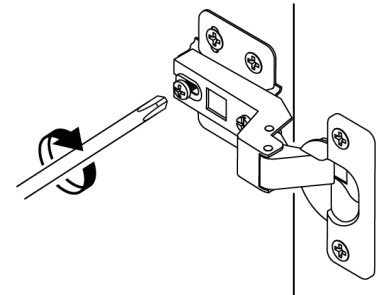
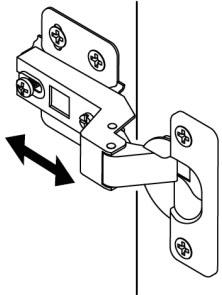
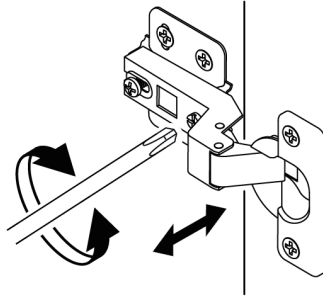
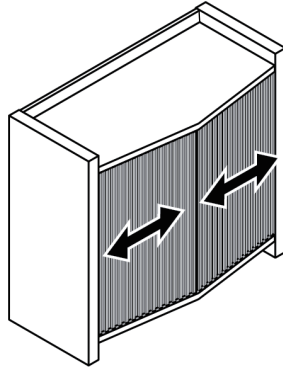

Adjust the screw on the hinge to microadjust the door from **side to side**.

Loosen the screws on the hinge arm to adjust the door **in and out**.

**17**

Rebound hinge, only need to gently press the doorpanel when opening the door.

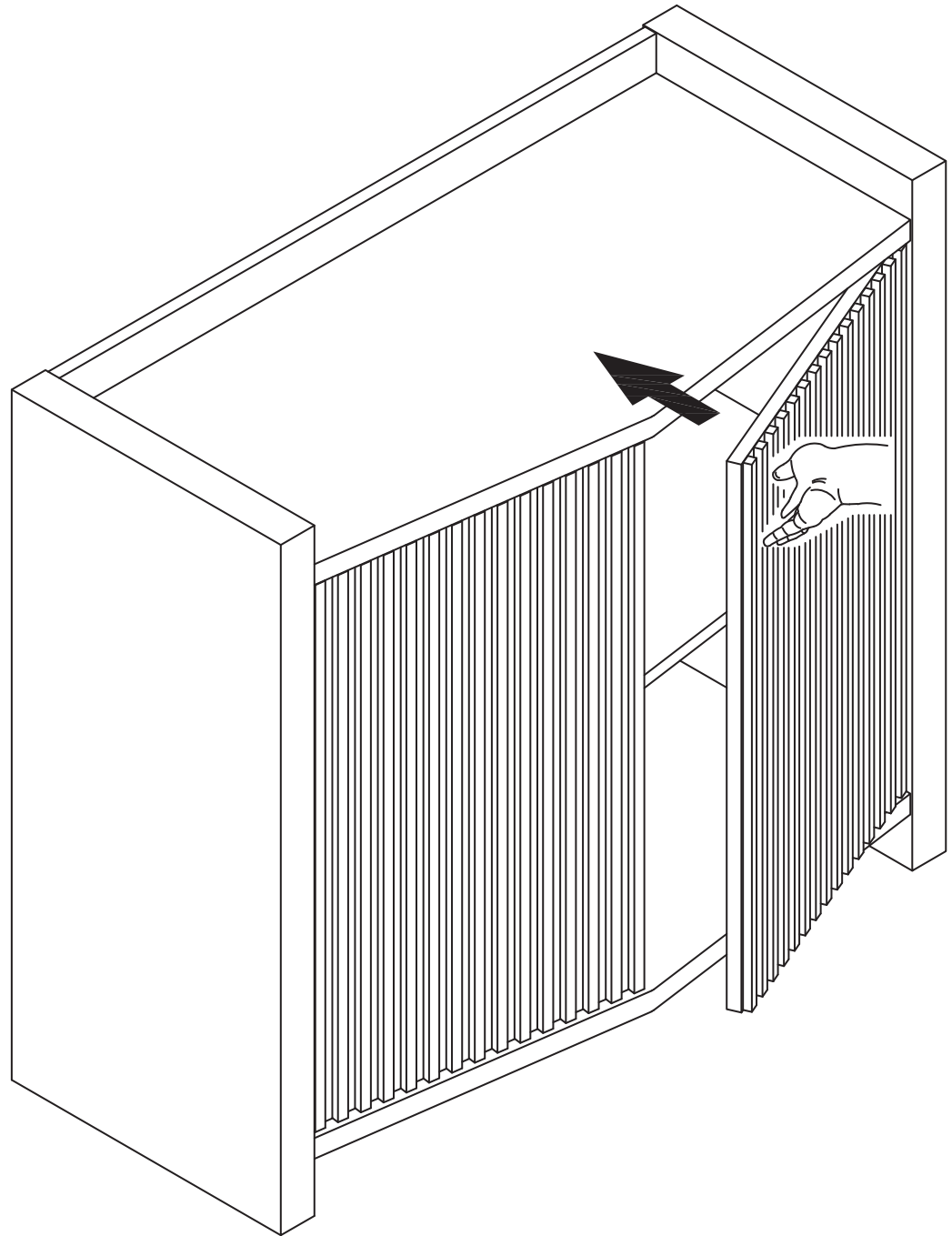

# 18

## Attaching anti-tipping straps

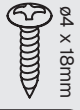

U 2x



V 2x

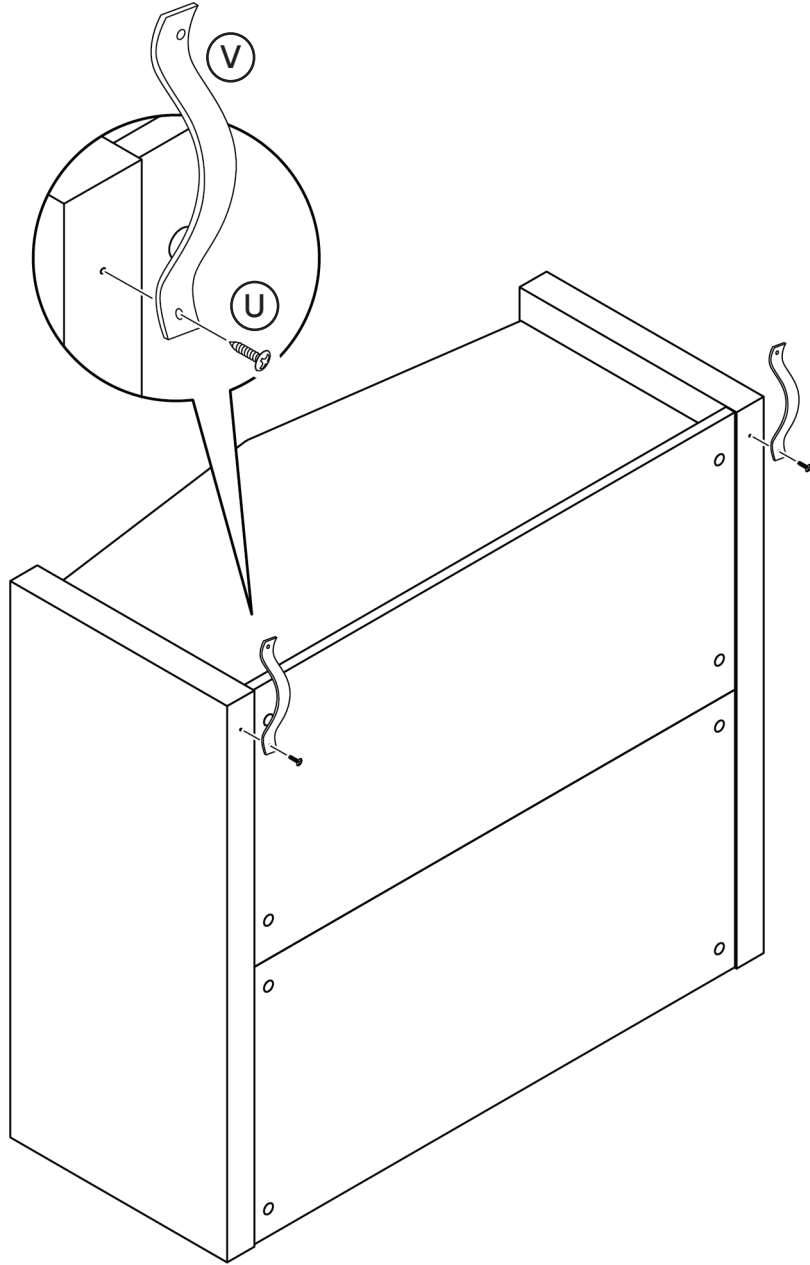

# 19

## Affixing Cabinet to a wall

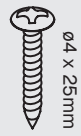

W 2x



X 2x

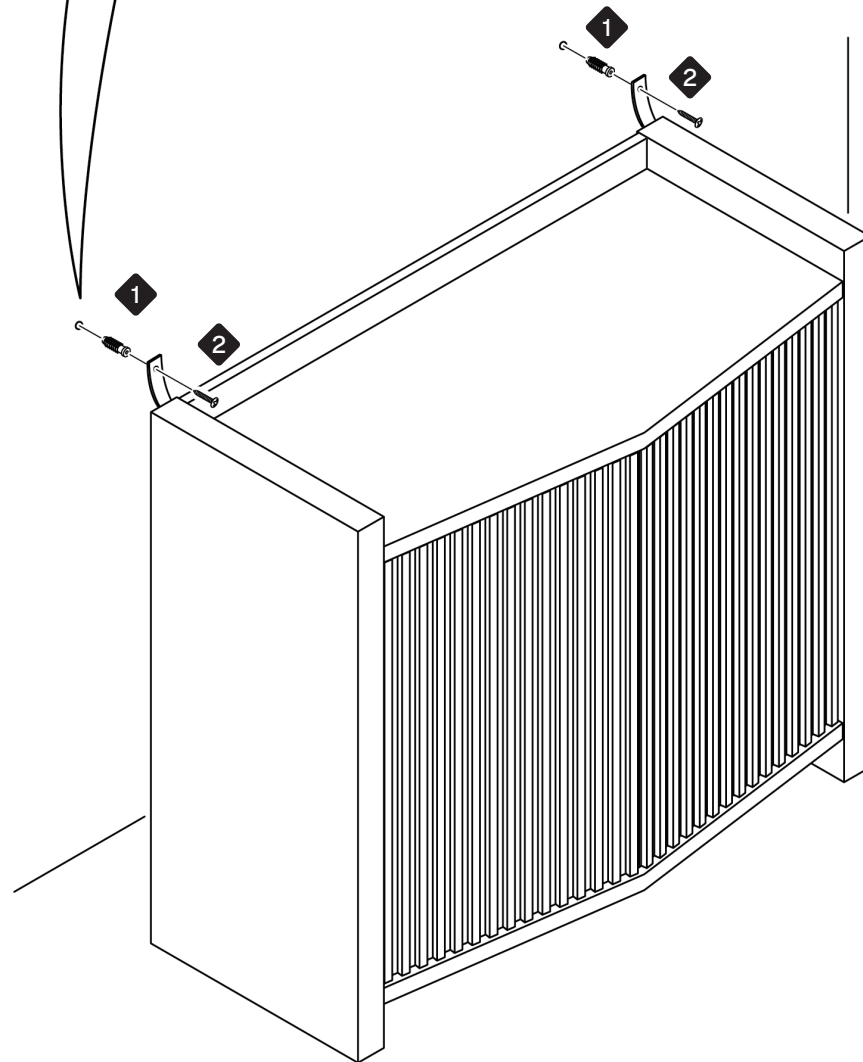
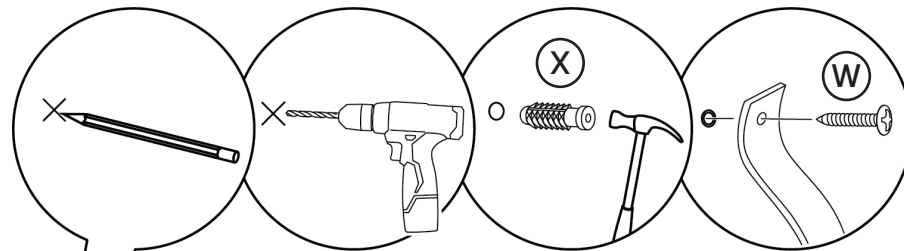

- Series or fatal crushing injuries may occur if the furniture tip-over. Furniture must permanently affixed to the wall with anti-tipping device(s) in order to prevent the furniture from tipping over.

\*Assembly symbols

1

2

Follow sequential order

# Care and Maintenance

Thank you for your purchase. We want your item to last as long as possible. To ensure the product gives you years of longevity, please follow the recommendations in this care and maintenance guide.



## Maintenance

- Tighten all bolts and crews again within the first 2 weeks of assembly.
- Check the tightness of all bolts every 2 months and retighten them if they come loose.



## Cleaning

- Clean the surface of the MDF (medium density fiberboard) with a lightly dampened cloth.
- A small amount of mild soap can be used if necessary.
- Dry the surface immediately after cleaning.



## Attention

DO NOT use bleach or alcohol based cleaner to clean the surface.  
DO NOT apply wood treatment on parts made with MDF.

MDF will swell and distort when exposed to water damage.  
Make sure to dry the furniture immediately after cleaning.



## Attention

The manufacturer and seller are not responsible for any and all liability relating to personal injury, property damage or losses, whether direct, indirect, or incidental, resulting from the incorrect attachment, improper use, inadequate maintenance, unapproved modification or neglect of this product.

## Warranty

Our products comes with a 1-year warranty from the date of delivery.  
Register your product on our website to enjoy out limited lifetime warranty!

## After-Sale Serice



Encounter any difficulties or missing parts?



Contact us or email us



We will send you replacement.



Hassle free!  
No need to worry about repackaging and sending your item back.