



MOOSOO

User Manual

**Stick Vacuum Cleaner
Model Number: K17**



For any questions and malfunctions of the appliance during use, please contact our customer service email: usa@moosoo.com

CONTENTS

Product Parts List	01
Important Safety Instructions	02
Overview & Product Components	05
Accessory Instructions	07
Start Using Your MOOSOO Appliance.....	08
Troubleshooting	15
Technical Specification	15
MOOSOO 1-Year Warranty.....	16

PRODUCT PARTS LIST

Dear customers, please check if the accessories are complete.

Name	Quantity
Main Engine	1
Aluminum Alloy Tube	1
LED Motorized Brush	1
Long Crevice Tool	1
Dusting Brush	1
Dust Cup	1
Adapter	1
User Manual	1
Stretchable Hose	1
Mini Motorized Head	1
Wall Hanger and Wall Anchors	1

IMPORTANT SAFETY INSTRUCTIONS

**IMPORTANT: SUITABLE FOR DRY LOCATIONS ONLY.
READ ALL INSTRUCTIONS BEFORE USE.
DO NOT USE OUTDOORS OR ON WET SURFACES.
RETAIN INSTRUCTIONS FOR FUTURE REFERENCE.**

⚠ WARNING: Basic safety precautions should always be followed when using an electrical appliance, including the following:

Personal Safety:

1. This MOOSOO appliance is not intended for use by young children or infirm persons with reduced physical, sensory or reasoning capabilities, or lack of experience and knowledge, unless they have been given supervision or instruction by a responsible person concerning use of the appliance to ensure that they can use it safely.
2. Don't let children play with the appliance as a toy. Close attention is necessary when used by or near children.
3. Use only as described in this MOOSOO Operating Manual. Do not carry out any maintenance other than that shown in this manual. Misuse or use of any accessory or attachment other than those recommended, may present a risk of personal injury.
4. Use extra care when cleaning stairs.
5. Keep the appliance and accessories away from fire source.
6. Do not put any object into openings. Do not use with any opening blocked; keep free of dust, lint, hair, and anything that may reduce airflow.
7. Keep hair, loose clothing, fingers, and all parts of the body away from openings and moving parts, such as the brush bar. Do not point the hose, wand or tools at your eyes or ears or put them in your mouth.

Electrical Safety:

1. Use only MOOSOO chargers for charging this MOOSOO appliance. Use only MOOSOO batteries: other types of batteries may burst, causing injury to persons and damage.

2. The charger has been designed for a specific voltage. Always check that the mains voltage is the same as that stated on the rating plate.
3. A charger that is suitable for one type of battery pack may create a risk of fire when used with another battery pack.
4. Do not use with a damaged cable or plug. If the supply cable is damaged it must be replaced by MOOSOO, its service agent or similarly qualified person in order to avoid a hazard.
5. Do not unplug by pulling on the cable. To unplug, grasp the plug, not the cable. The use of an extension cable is not recommended.
6. Never carry the adapter by the cord.
7. Do not pull the cord to disconnect from a socket, grasp the plug and pull to disconnect.
8. Don't wrap the cord around the adapter when storing.
9. Keep the cable away from heated surfaces. Do not close a door on the cable, or pull the cable around sharp edges or corners. Arrange the cable away from traffic areas and where it will not be stepped on or tripped over. Do not run the appliance over the cable.
10. The supply cord cannot be replaced. If the cord is damaged the charger should be discarded and replaced.
11. Do not handle any part of the plug or appliance with wet hands.
12. Do not install, charge or use this appliance outdoors, in a bathroom or within 3 meters (10 feet) of a pool. Do not use on wet surfaces and do not expose to moisture, rain or snow.
13. The charger must be removed from the socket before removing the battery, cleaning or maintaining the appliance.

Battery Safety:

1. This appliance includes Li-ion batteries, do not incinerate batteries or expose to high temperatures, as they may explode.
2. Liquid ejected from the battery may cause irritation or burns.
3. In an emergency situation contact professional help immediately.
4. In the unlikely event that liquid leaks from the battery do not touch the liquid and observe the following precautions:

- Skin contact – Wash with soap and water.
 - Inhalation – Expose to fresh air and seek medical advice.
 - Eye contact – Immediately flush eyes thoroughly with water for at least 15 minutes. Seek medical attention.
5. Shorting the battery terminals may cause burns or fire.
 6. When the battery pack is not in use, keep it away from paper clips, coins, keys, nails, screws or other small metal objects that could make a connection from one terminal to another.
 7. When you dispose of the appliance remove the battery and dispose of the battery safely in accordance with local regulations.

Service:

1. Before using the appliance and after any impact, check for signs of wear of damage and repair as necessary.
2. Do not use the appliance if any part is damaged or defective.
3. Repairs should be carried out by a service agent or a suitably qualified person in accordance with relevant safety regulations. Repairs by unqualified persons could be dangerous.
4. Never modify the appliance in any way as this may increase the risk of personal injury.
5. Use only MOOSOO recommended accessories and replacement parts.

Intended Use:

1. This MOOSOO appliance is intended for dry vacuum cleaner ONLY.
2. Do not pick up water or use on wet surfaces.
3. Do not use to pick up flammable or combustible liquids, such as petrol, or use in areas where they or their vapours may be present.
4. Do not pick up anything that is burning or smoking, such as cigarettes, matches, or hot ashes.
5. Don't use on concrete, tarmacadam or other rough surfaces.

WARNING:

1. Clean the appliance only with a dry cloth. Do not use any lubricants, cleaning agents, polishes or air fresheners on any part of the appliance.
2. Store the appliance indoors. Do not use or store it below 3°C (37.4°F). Ensure the appliance is at room temperature before operating.
3. Never immerse the electric machine in water and do not clean in a dish washer.

OVERVIEW & PRODUCT COMPONENTS

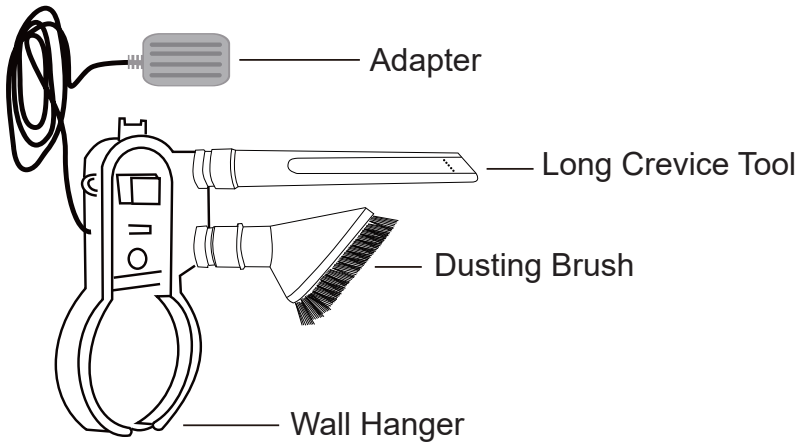

Screws



Plastic Wall Anchors

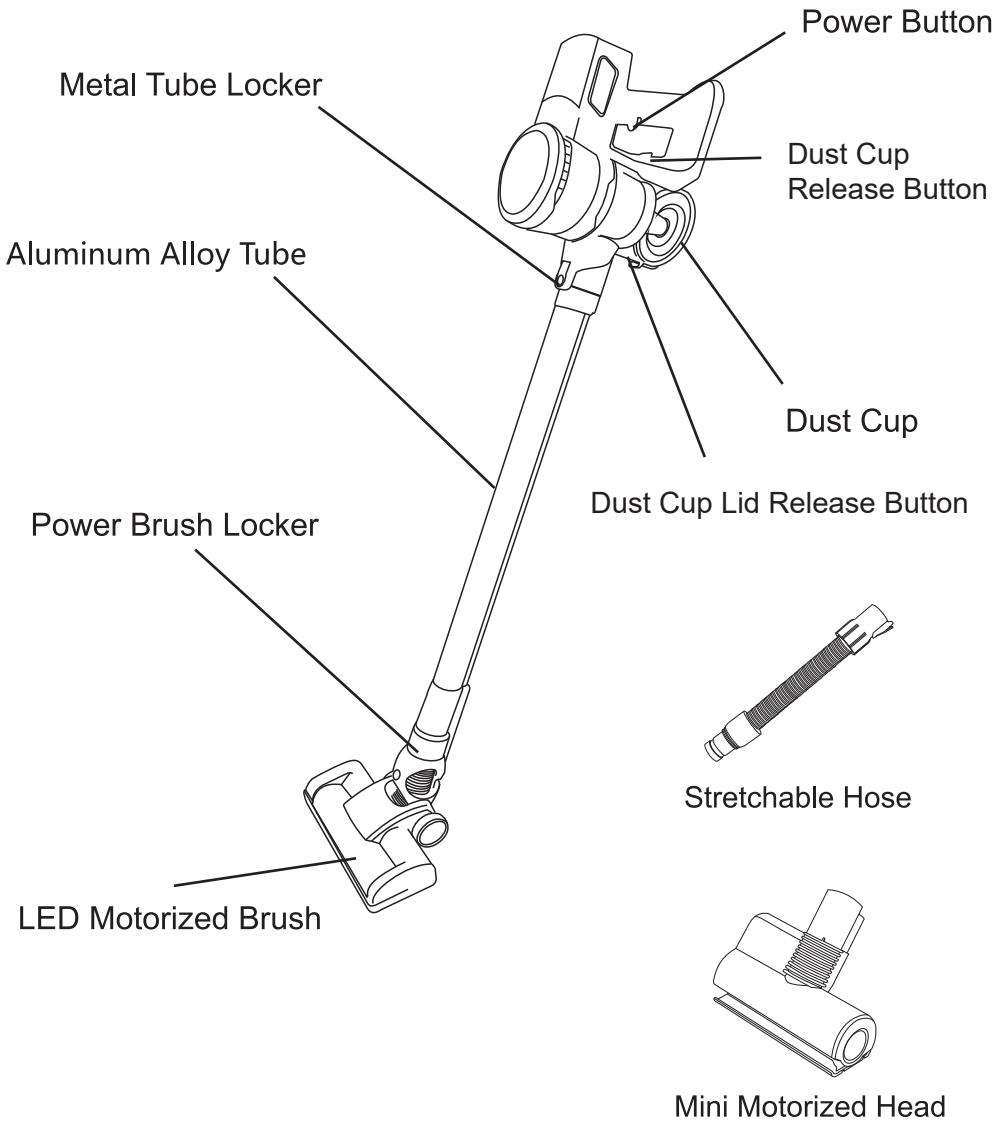

ACCESSORY INSTRUCTIONS

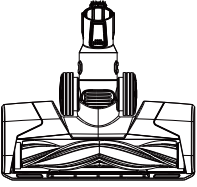

LED Power Brush

Ideal for hard floor/rugs/carpets, very effective for agitating dirt embedded in the carpet. LED lights help you to clean even in shadow.



Long Crevice Tool

Ideal for corners, niches and other hard -to-reach places.

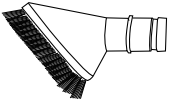

Dusting Brush

Ideal for vacuuming upholstered furniture, curtain, etc..

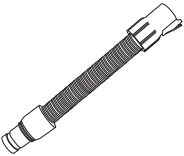

Stretchable Hose

The MOOSOO hose conventional state of about 18.1 in, the longest stretch to 47.2 in, could be contact with crevice nozzle, 2-in-1 dusting brush or 2-in-1 square brush.

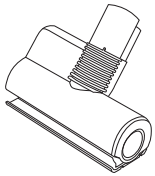

Mini Motorized Head

Quickly converts to hand-held mode, more efficient for vacuuming pet hair on furniture like sofa, bed etc .



Wall Hanger and Wall Anchors

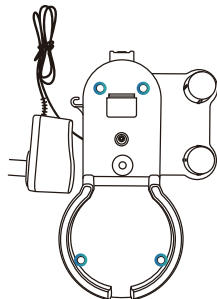

At first, please find a place on the wall where is high enough for hanging the vacuum cleaner while the socket is closed enough for charging. Secondly, drill four holes on the wall and put four plastic wall anchors into the holes. At last, put the wall hanger on the wall aiming these four holes and put the screws through the hanger into anchors.

START USING YOUR MOOSOO APPLIANCE

How to Use as a Stick Vacuum Cleaner

1. Assemble the dust cup by twisting it in a counterclockwise direction.

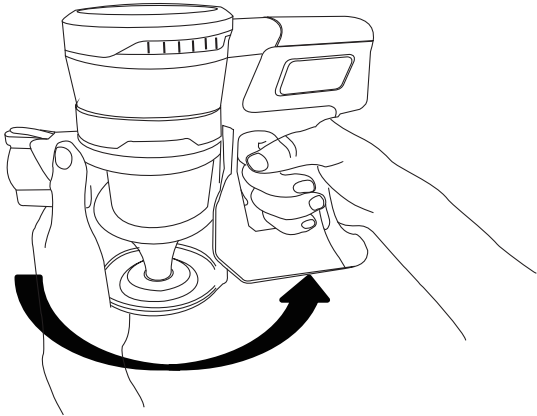

2. Insert the metal tube into the body until you hear a click (see below).

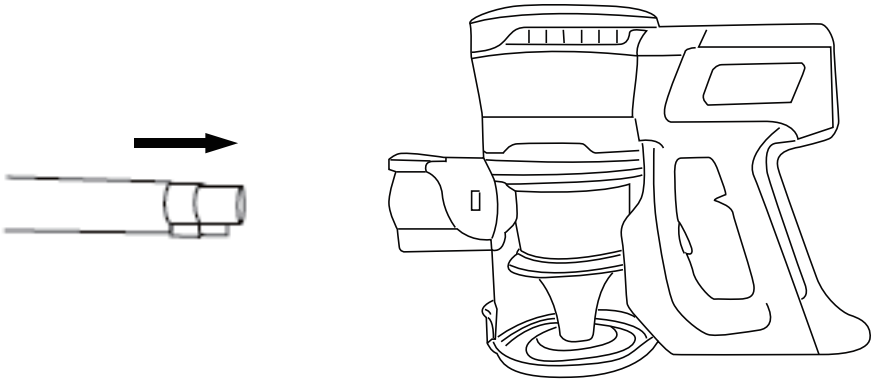

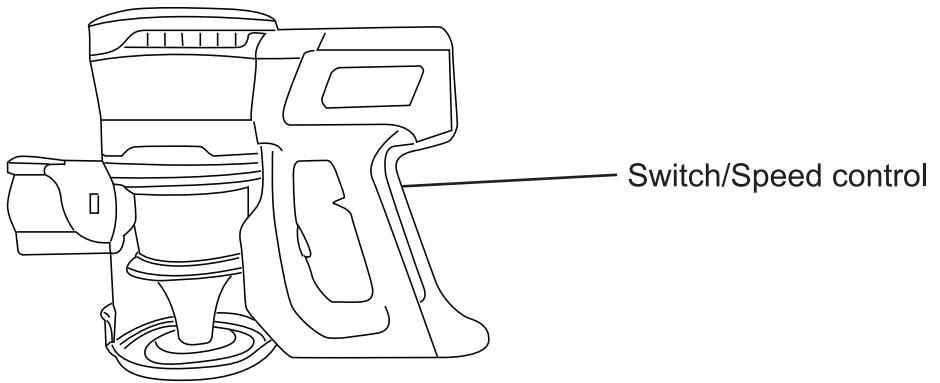

A Low power

Press the switch button once.

B High power

Press the switch button twice.

Press the button a third time to power off. See the diagram below:

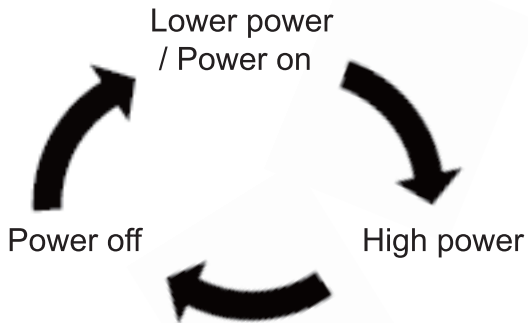

3. Attach the brush to the head of metal tube as shown below:

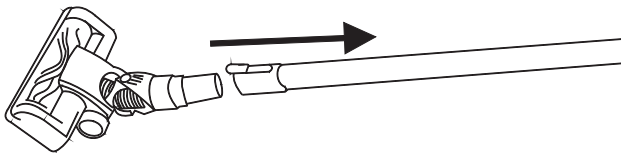

How to Use as a Handheld Vacuum

Insert your chosen accessory into the body as shown below:

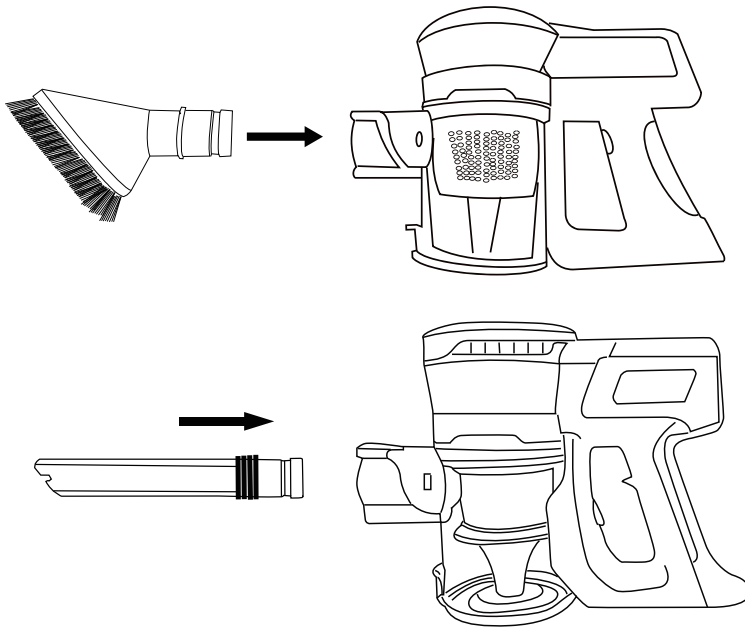

- ◆ Do not use without the dust cup and filter in place.
- ◆ Fine dirt such as flour should only be vacuumed in very small amounts.
- ◆ Do not use the appliance to pick up sharp hard objects, small toys, pins, paper clips, etc. They may damage the appliance.
- ◆ When vacuuming, certain carpets may generate small static charges in the clear bin or wand. These are harmless and are not associated with the mains Electricity supply. To minimize any effect from this, do not put your hand or insert any object into the clear bin unless you have first emptied it. Clean the dust cup with a damp cloth only.
- ◆ Do not rest the appliance on chairs, tables, etc.
- ◆ Do not press down on the nozzle with excessive force when using the appliance as this may cause damage.
- ◆ Do not leave the cleaner head in one place on delicate floors.

Battery Charging

1. The battery power indicator will blink red when the battery is low and automatically power off the machine when the battery dies. To charge, place the machine on the wall hanger as shown below

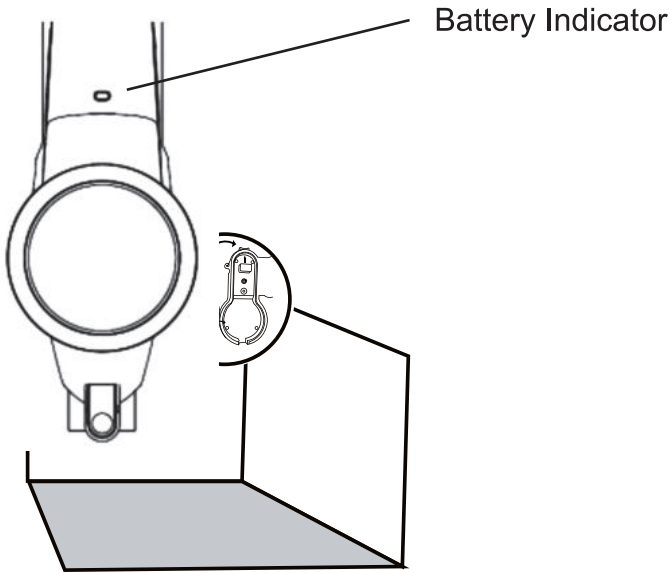

2. Once plugged into the wall hanger, the indicator light will blink red. The battery is fully charged when the light turns green.



How to Empty the Dust Cup

1. Press the metal tube locker then take it out

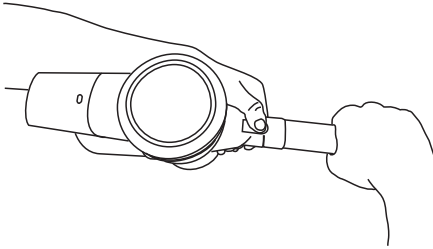

2. Press the release button

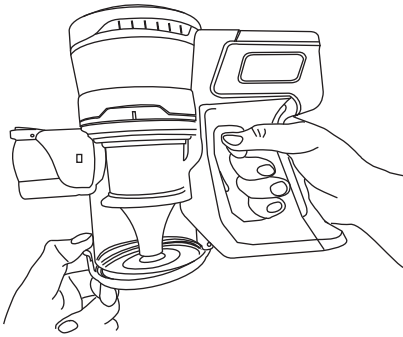

3. Empty the dust cup

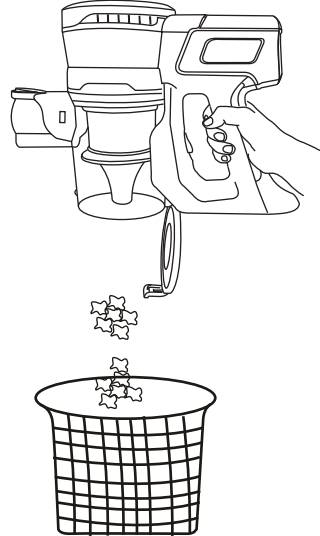

- ◆ Empty as soon as the dirt reaches the level of the MAX mark – do not overfill.
- ◆ Ensure the appliance is disconnected from the charger before emptying the dust cup. Be careful not to pull the 'ON' trigger.
- ◆ To make emptying the dust cup easier, it is advisable to remove the wand and other floor tools.
- ◆ To minimize dust/allergen contact when emptying, encase the dust cup tightly in a plastic bag and empty.
- ◆ Close the dust cup base so it clicks into place and is secure.

How to Maintain the Filter

1. Press the dust cup lock, and turn it in a clockwise direction.

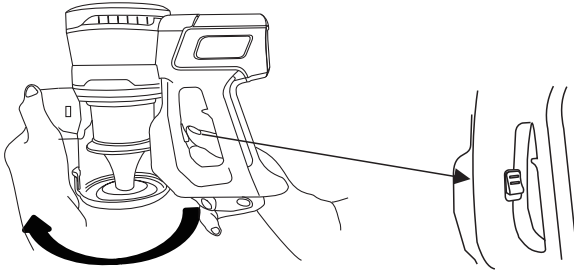

2. Take out the filter case, then take out the filter.

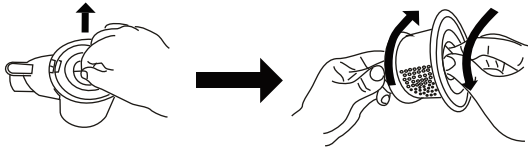

3. Thoroughly wash the filter case and HEPA filter.

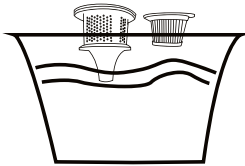

4. Be sure to dry the filters completely.

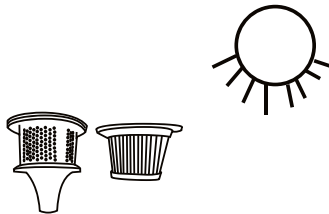

5. After drying, reassemble the filters as shown below:

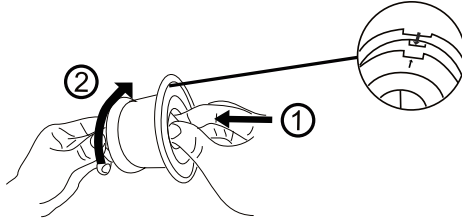

6. Put the filter case back into the dust cup.

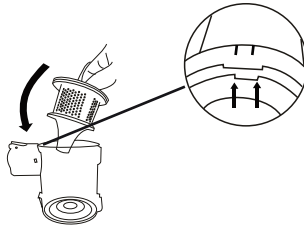

7. Attach the dust cup by twisting in a counterclockwise direction.

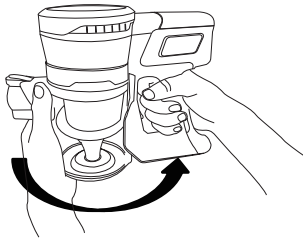

- ◆ Ensure the appliance is disconnected from the charger before removing the filter. Be careful not to pull the 'ON' trigger.
- ◆ Check and wash the filter regularly according to instructions to maintain performance.
- ◆ The filter may require more frequent washing if vacuuming fine dust or if used mainly in 'High Powerful suction' mode.
- ◆ Wash the filter with cold water only.
- ◆ Run water over the outside of the filter until the water runs clear.

- ◆ Lay the filter on its side to dry. Leave to dry completely for a minimum of 24 hours.
- ◆ Do not put the filter in a dishwasher, washing machine, tumble dryer, oven, microwave or near a naked flame.
- ◆ To refit, place the dry filter back into the top of the appliance. Make sure it is fitted properly

TROUBLESHOOTING:

Vacuum is not cleaning well	<ol style="list-style-type: none"> 1.Empty the dust bin 2.Check that the dust bin is correctly attached 3.Check that the filter is correctly attached 4.Clean the filter
Vacuum suddenly stops	<ol style="list-style-type: none"> 1.Charge the battery 2.Clear debris from the brush bar
Battery will not charge	<ol style="list-style-type: none"> 1.Check connections 2.Check wall socket
Motorized brush doesn't spin	<ol style="list-style-type: none"> 1.Make sure the dust cup is in the locked position 2.Check the electrical inputs in the dirt chamber get stuck or not

TECHNICAL SPECIFICATION:

Battery	22.2V/2200mAh
Charging period	4 hours
Battery charger output	26.5V/500mA
Usage time	30min (low speed), 15min (high speed)
Power	200W Brushless Motor
Vacuum	23Kpa
Airflow	10dm ³ /s

WARRANTY

CUSTOMER CARE

The 1-year Limited Warranty is valid for products purchased from our MOOSOO only, starting from the date of the original retail purchase. We will provide customer service for any defects in quality or materials under normal, non-commercial use.

1. According to the requirements outlined in this instruction manual, the warranty is subject to the following conditions and exclusions.
2. This warranty provides, at no extra cost to you all labor and parts necessary to ensure your machine is in proper operating condition during the warranty period. We provide the repair or replacement of your MOOSOO appliance if your MOOSOO appliance is found to be defective due to faulty materials, workmanship function within 1 year of purchase or delivery. (If any part is no longer available or out of manufacture, we will replace it with a functional replacement part).

WHAT IS NOT COVERED

1. Under your MOOSOO guarantee, MOOSOO shall not be liable for costs of repair or replacement of a product incurred as a result of: Accidental damage, faults caused by negligent use or care, misuse, neglect, careless operation or handling of the MOOSOO appliance which is not in accordance with this MOOSOO Operation Manual.
2. Machines purchased from an unauthorized dealer.
3. Use of parts and accessories other than those produced or recommended by MOOSOO.
4. Repairs or alterations carried out by unauthorized parties or agents.
5. Use of the machine other than for normal domestic purpose, e.g. for commercial or rental purposes.
6. Reduction in battery run time due to battery age or use.

WARRANTY

WARRANTY SERVICE

- 1.If you have a query about your MOOSOO appliance, please contact the MOOSOO customer service email: usa@imoosoo.com
- 2.Please inform us your model name/number, purchase date, order number, machine problem and your requirement.
- 3.Your model number can be found on rating plate. For information on your rating plate see the inside front cover.
- 4.Please keep your purchase receipt in a safe place to ensure you have this information.
- 5.Service under this warranty will not extend the available time of warranty.