

MANUAL DE MONTAGEM

ASSEMBLY INSTRUCTIONS

INSTRUCCIONES DE MONTAJE

NOTICE DE MONTAGE

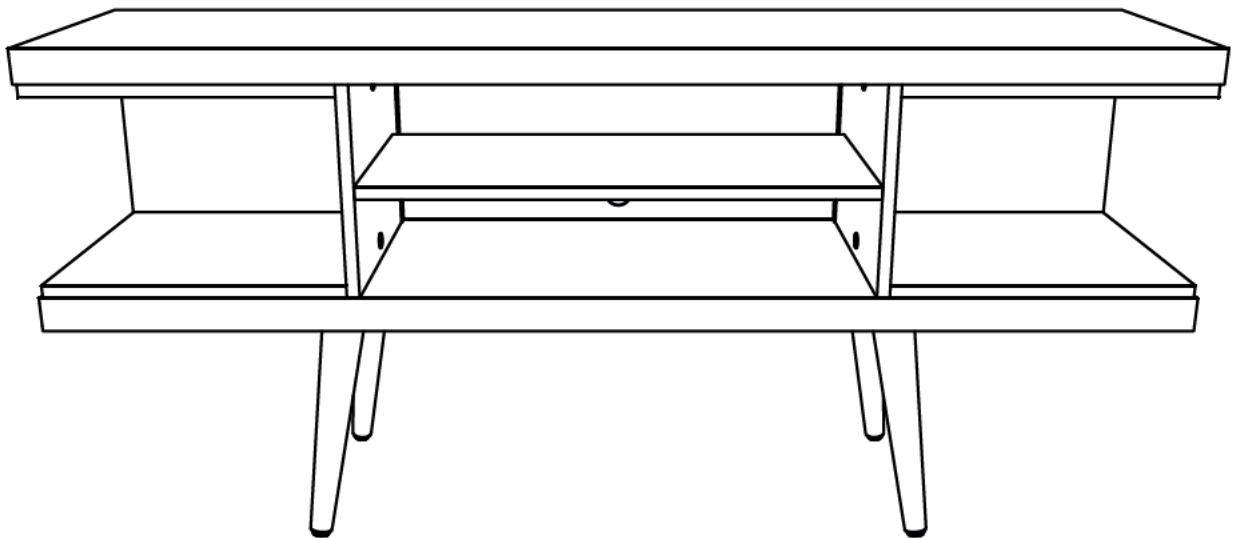

OBSERVAÇÕES IMPORTANTES

IMPORTANT REMARKS

OBSERVACIONES IMPORTANTES

REMARQUES IMPORTANTES



Nunca escale ou se apoie sobre o móvel. Você pode sofrer graves acidentes.

Never climb or lean on the furniture. You may suffer serious accidents.

Nunca escale o apoie sobre el mobiliario. Usted puede sufrir graves accidentes.

Ne montez jamais sur le meuble. Vous pourriez subir un grave accident.



Movimente o móvel com cuidado, sem arrastar. Peça ajuda a outra pessoa para fazê-lo.

Move the piece carefully, don't drag it. Ask for someone else's help to do so.

Mover la unidad con cuidado, sin arrastar. Pedir ayuda da otra persona para moverlo.

Déplacez les meubles avec précaution sans le faire glisser. Demandez a quelqu'un de vous aider à le faire.



Limpe com um pano limpo e umedecido em água e sabão neutro. Não utilizar produtos químicos e abrasivos.

Wipe clean using a damp cloth and a mild cleaner. Don't use abrasive and chemical products.

Limpie con un paño limpio humedecido con agua y jabón neutro. No utilice productos químicos y abrasivos.

Nettoyez avec un chiffon propre imbibé avec d'eau et de savon doux. N'utilisez pas de produits chimiques et abrasifs.

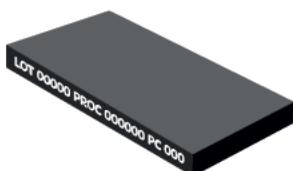

Observe os números impressos nas bordas para identificar as peças.

Identify the parts by observing the number printed on their edges.

Identifique las piezas observando el numero impreso en sus bordes.

Notez les numéros imprimés sur les bords pour identifier les pièces.



Utilize a embalagem para forrar a área de montagem e separar todas as peças.

Use the packaging to cover the assembly area and separate all parts.

Utilice el embalaje para cubrir la area de montaje y separe las piezas.

Couvrez la zone d'assemblage avec l'emballage pour séparer le pièces.



Não colocar objetos em alta temperatura diretamente sobre superfícies de vidro.

Do not place high-temperature objects directly on glass surfaces.

No coloque objetos de alta temperatura directamente sobre superficies de vidro.

Ne placez pas d'objets à haute température directement sur les surfaces en verre.

ACESSÓRIOS HARDWARE HERRAJES ACCESSOIRES

Identifique e separe os acessórios utilizados. Em cada embalagem, uma etiqueta identifica as peças e onde utilizá-las.

Identify and separate the hardware used in the assembly. There's a label on each package identifying the parts and where to use them.

Identifique y separe los accesorios utilizados en el montaje. Observe la etiqueta en cada paquete para saber donde montar.

Identifiez et séparez les accessoires à être utilisés. Dans chaque emballage il y a une étiquette pour identifier les pièces et où les utiliser.

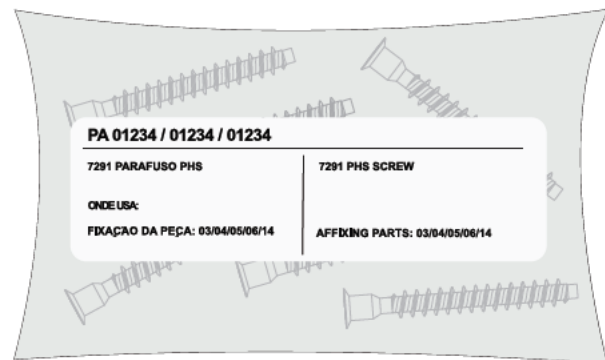

PA19600 - 1350mm

L:1350mm A:610mm P:356mm

W:53.15in H:24.02in D:14.02in

L:1350mm A:610mm P:356mm

L:1350mm H:610mm P:356mm

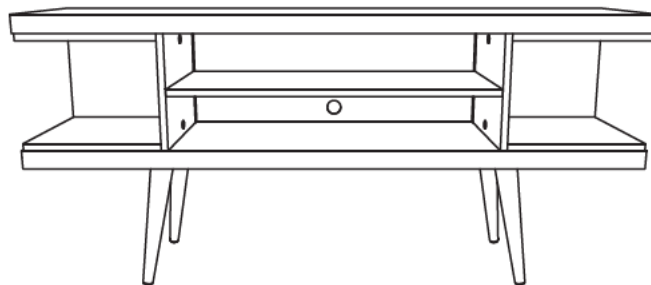

A
 ADESIVO
 STICKER
 ADHESIVO
 AUTOCOLLANT
 (04X)



B
 COD. 10063
 (10X)



C
 COD. 1668
 6.0 x 30
 (20X)



D
 COD. 8471
 (04X)



E
 COD. 0599
 (10X)



F
 COD. 3706
 4.0 x 30
 (08X)



G
 COD. 8056
 4.5 x 16
 (16X)

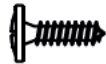

H
 COD. 9333
 5.0 x 50
 (08X)



I
 COD. 0357
 8.0 x 8.0
 (16X)



MONTAGEM NECESSITA DUAS PESSOAS
 ASSEMBLY REQUIRES 2 PEOPLE
 EL MONTAJE NECESITA 2 PERSONAS
 MONTAGE A 2 PERSONNES

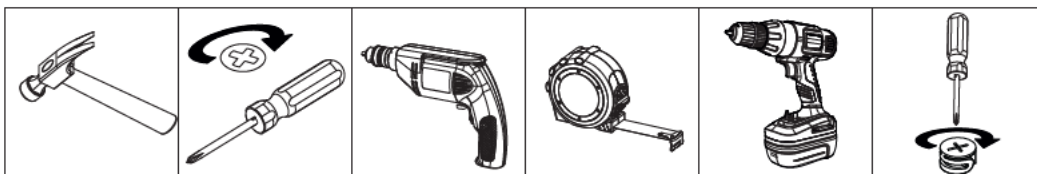

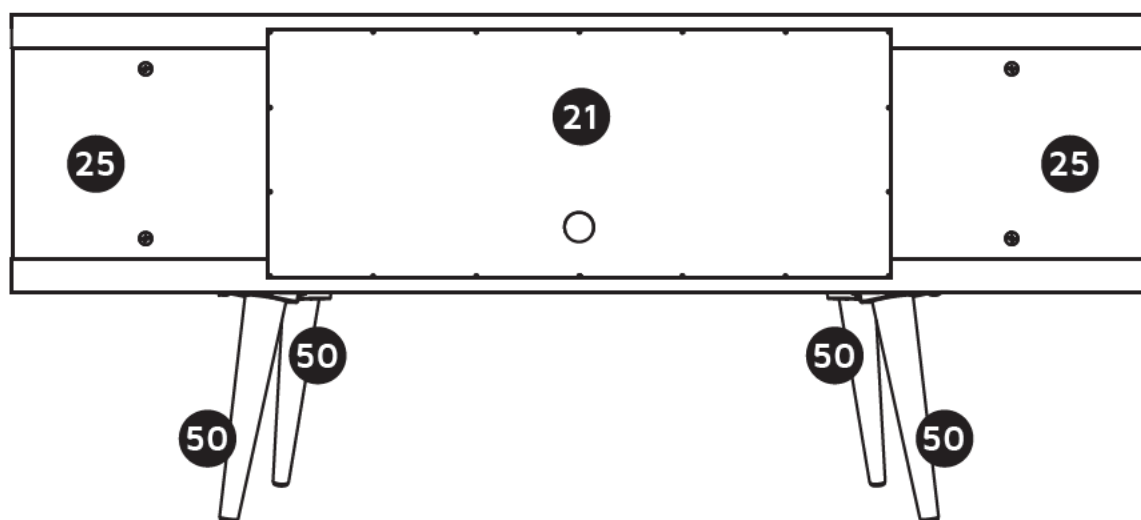
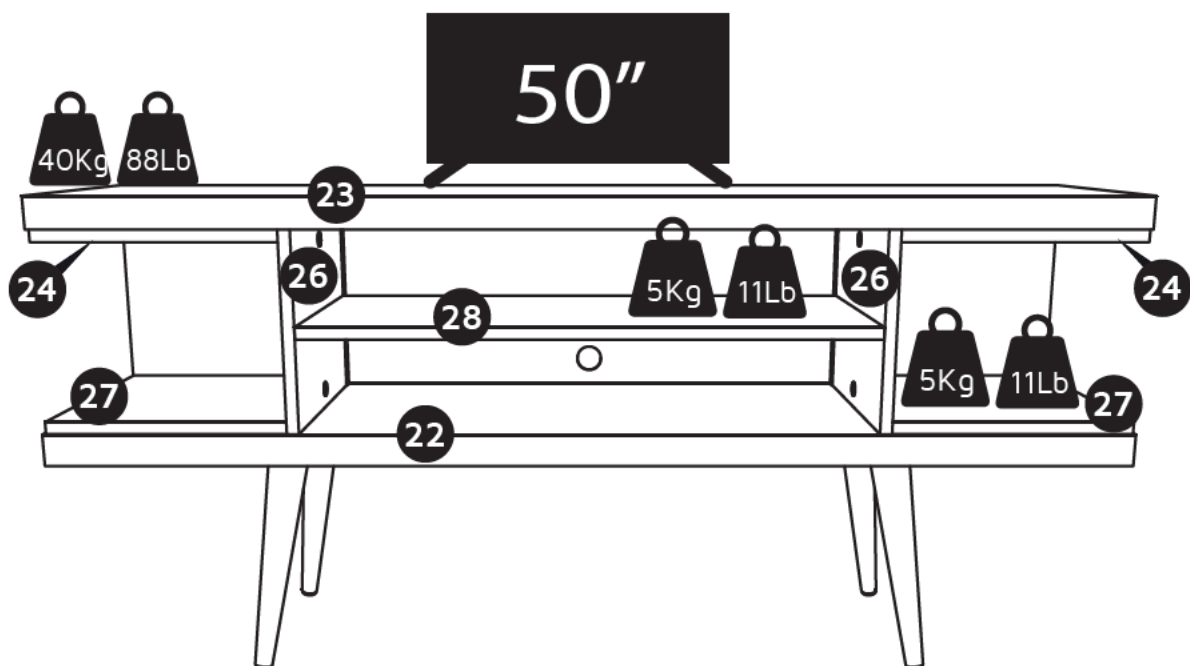

DESCRIPTION/ DESCRIPCIÓN/ DESCRIPTION

CÓD:19600						
PEÇA PART PIEZA	QUANTIDADE QUANTITY CANTIDAD QUANTITÉ	DESCRIÇÃO	DESCRIPTION	DESCRIPCIÓN	DESCRIPTION	CAIXA BOX CAJA BOÎTE
21	01	FUNDO	BLACK PLATE	FONDO	FOND	01
22	01	BASE	BASE	BASE	BASE	01
23	01	TAMPO	TOP PANEL	PANEL SUPERIOR	PLATEAU	01
24	02	PAINEL SUP. NICHOS	NICHE TOP PANEL	SUPERIOR NICHOS	LATTES INFÉRIEURES	01
25	02	FUNDO NICHOS	NICHE BACK PANEL	FONDO NICHOS	FOND DE L'ÉTAGÈRE CARRÉ	01
26	02	LATERAL NICHOS	SIDE NICHE	NICHOS LATERAL	ÉTAGÈRE CARRÉ CÔTÉ	01
27	02	INFERIOR NICHOS	NICHE BOTTOM	NICHOS INFERIOR	BAS DE L'ÉTAGÈRE CARRÉ	01
28	01	DIVISÓRIA MAIOR	LONG DIVIDER	DIVISION MAYOR	DIVISEUR PLUS GRAND	01
50	04	PÉ	LEG	PATA	PIED	01



01

C COD. 1668	E COD. 0599
	

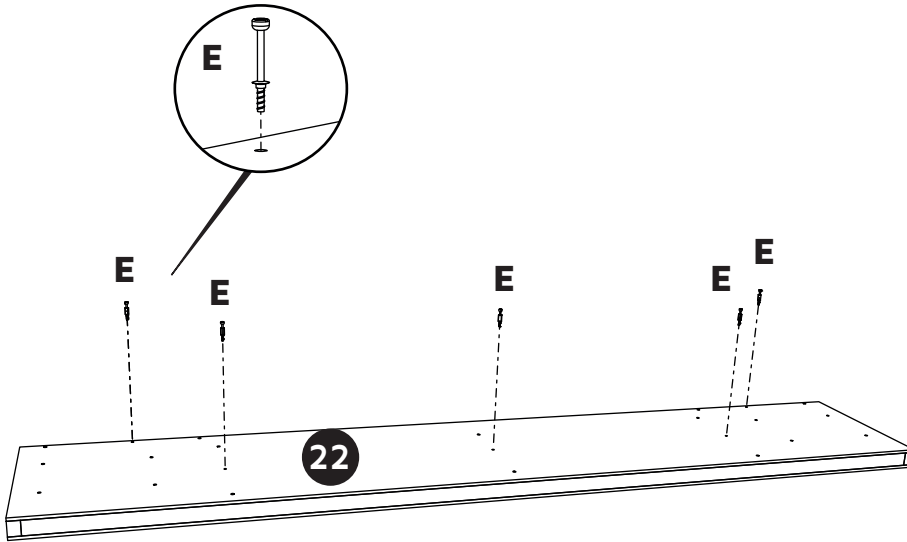

PASSO 1
Parafusar minifix 5x**0599**
na base **22**

STEP 01
Screw minifix 5x**0599**
on base **22**

PASO 01
Atornillar el minifix 5x**0599**
en la base **22**

ÉTAPE 01
Vissez le minifix 5x**0599**
dans la base **22**

02

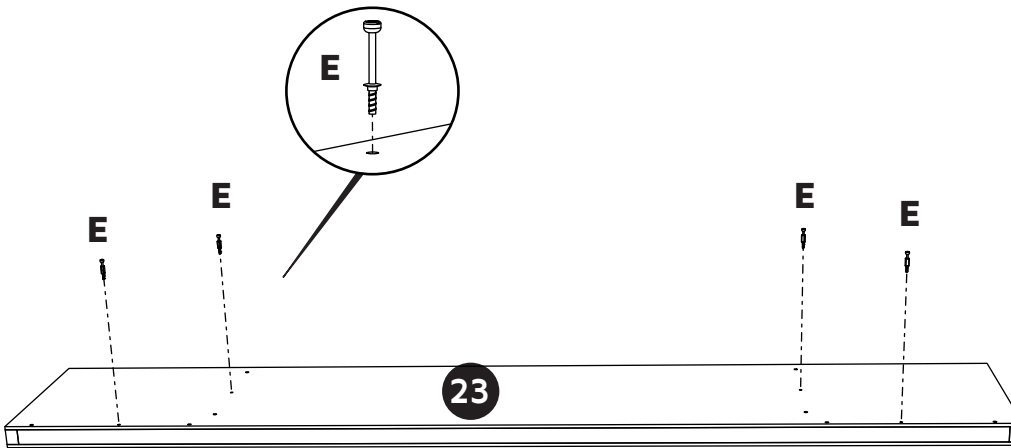

PASSO 2
Parafusar minifix 4x**0599**
no tampo **23**

STEP 02
Screw minifix 4x**0599**
on top board **23**

PASO 02
Atornillar el minifix 4x**0599**
en la cubierta **23**

ÉTAPE 02
Vissez le minifix 4x**0599**
dans le plateau **23**

03

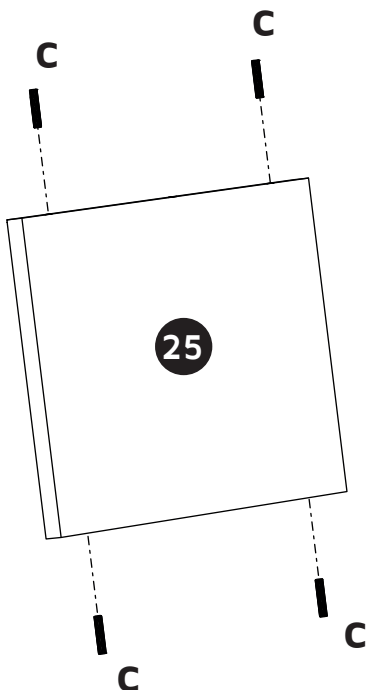

PASSO 03
Encaixar cavilhas 4x**1668**
no fundo nicho **25**

STEP 03
Insert dowels 4x**1668**
on the niche back panel **25**

PASO 03
Clavijas de ajuste 4x**1668**
en fondo nicho **25**

ÉTAPE 03
Insérez les chevilles 4x**1668**
en bois dans les fentes du
fond de la niche **25**

(2x)

04

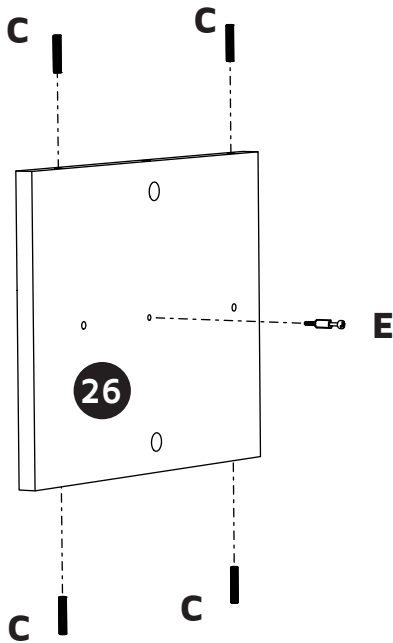

(2x) c I

B	C	E
COD. 10063	COD. 1668	COD. 0599

PASSO 04

Encaixar cavilhas 4x**1668** e parafusar minifix 1x**0599** na lateral nicho **26**

STEP 04

Insert dowels 4x**1668** and screw minifix 1x**0599** on side niche **26**

PASO 04

Clavijas de ajuste 4x**1668** y atornillar el minifix 1x**0599** en nicho lateral **26**

ÉTAPE 04

Insérez les chevilles 4x**1668** en bois et vissez le minifix 1x**0599** dans le côté gauche de la niche **26**

05

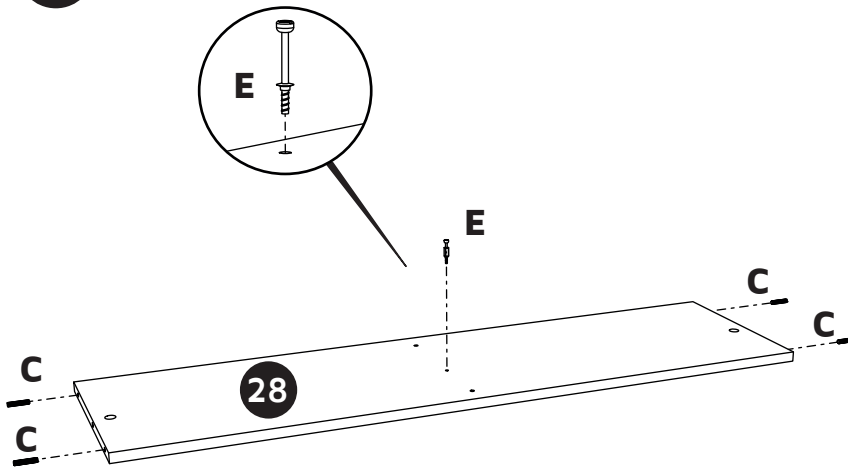

PASSO 05

Encaixar cavilhas 4x**1668** e parafusar minifix 1x**0599** na divisória maior **28**

STEP 05

Insert dowels 4x**1668** and screw minifix 1x**0599** on long divider **28**

PASO 05

Clavijas de ajuste 4x**1668** y atornillar el minifix 1x**0599** en la division mayor **28**

ÉTAPE 05

Insérez les chevilles 4x**1668** en bois et vissez le minifix 1x**0599** dans le diviseur plus grand **28**

06

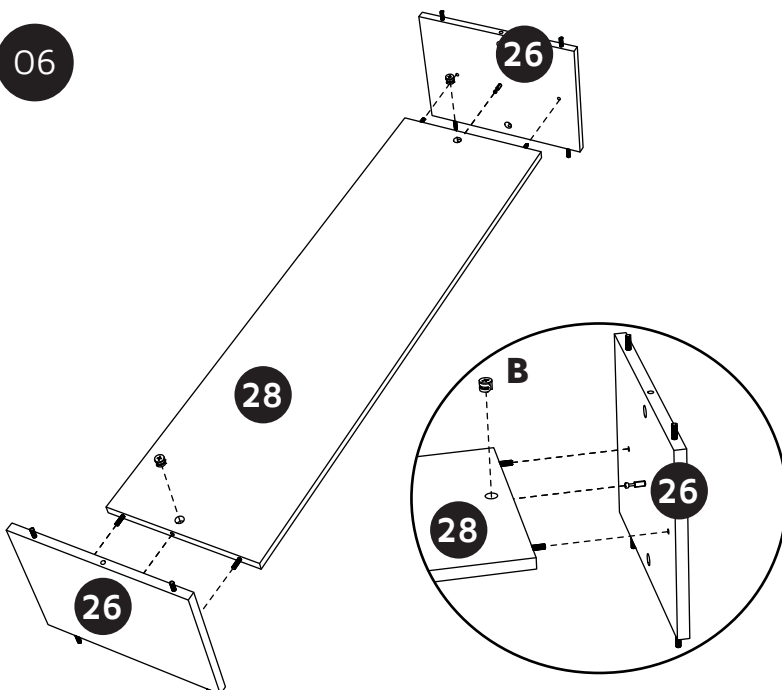

PASSO 06

Encaixar laterais nicho **26**
Parafusar castanhas 2x**10063**

STEP 06

Attach sides **26**
Screw nuts 2x**10063**

PASO 06

Montarlas laterales **26**
Atornillar las tuercas 2x**10063**

ÉTAPE 06

Insérez les le côté gauche de la niche **26**
Vissez le brunette 2x**10063**

07

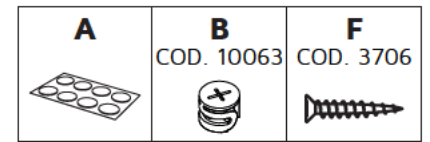
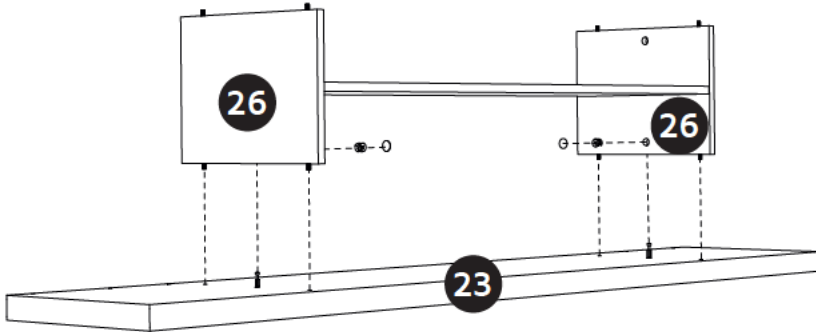
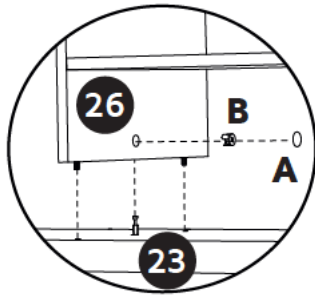

PASSO 07

Encaixar laterias nicho **26** Parafusar castanhas 2x**10063** e colar **2** adesivos

STEP 07

Attach sides **26** Screw nuts 2x**10063** and place **2** stickers

PASO 07

Montar las laterales **26** Atornillar las tuercas 2x**10063** y pegar **2** adhesivos

ÉTAPE 07

Insérez les le côté gauche de la niche **26** Vissez le brunette 2x**10063** et collez **1** l'adhésif

08

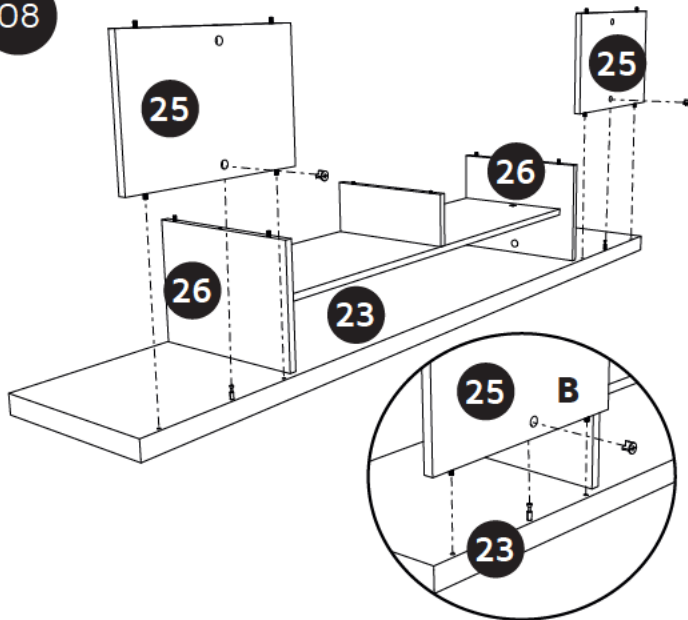

PASSO 08

Encaixar fundo nicho **25** Parafusar castanhas 2x**10063**

STEP 08

Attach niche back **25** Screw nuts 2x**10063**

PASO 08

Montar el fondo nicho **25** Atornillar las tuercas 2x**10063**

ÉTAPE 08

Insérez le fond de la niche dans le fond de la niche **25** Vissez le brunette 2x**10063**

09

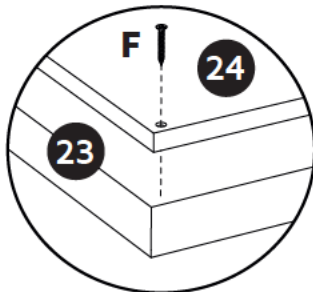

PASSO 09

Encaixar painel sup. nicho **24** Parafusar 8x**3706**

STEP 09

Attach niche top **24** Screw 8x**3706**

PASO 09

Montar el panel superior **24** Atornillar 8x**3706**

ÉTAPE 09

Insérez le lattes inférieures **24** Vissez 8x**3706**

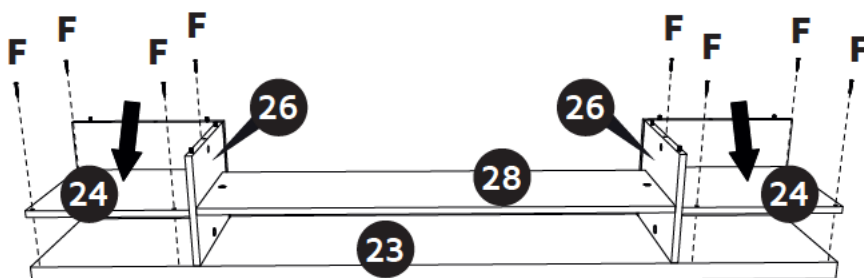

10

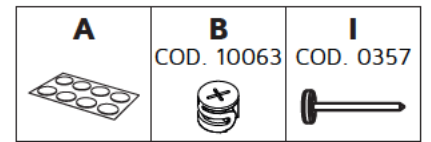
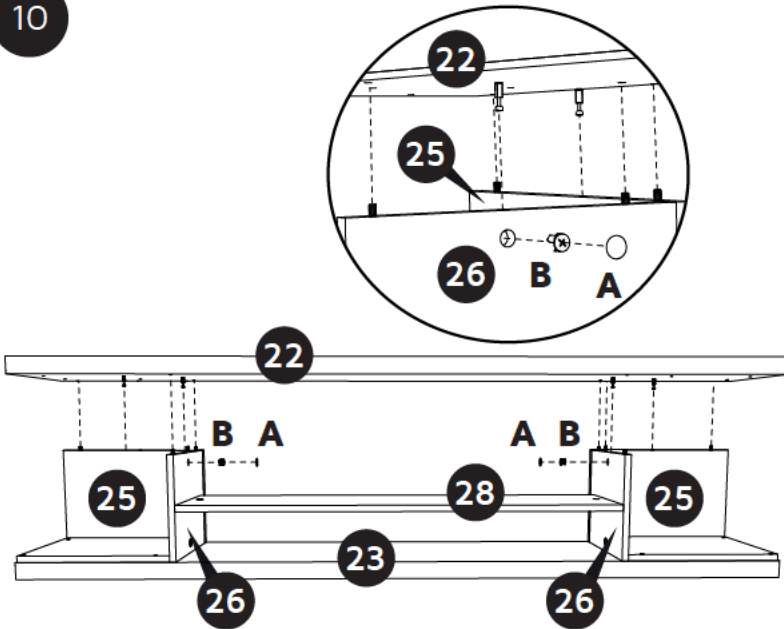

PASSO 10

Encaixar base **22**

Parafusar castanhas 2x**10063** e colar **1** adesivo

STEP 10

Attach base **22**

Screw nuts 2x**10063** and place **3** stickers

PASO 10

Montar base **22**

Atornillar las tuercas 2x**10063** y pegar **3** adhesivos

ÉTAPE 10

Insérez le base **22**

Vissez le brunette 2x**10063** et collez **3** l'adhésif

11

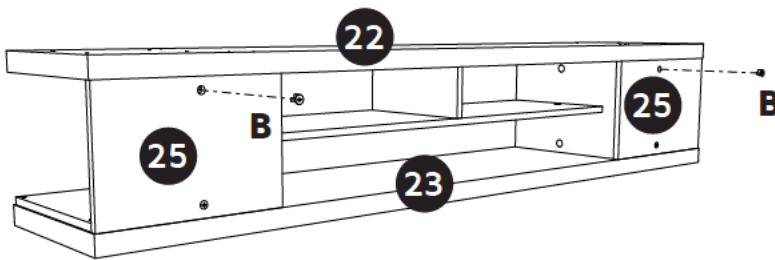

PASSO 11

Parafusar castanhas 2x**10063**

STEP 11

Screw nuts 2x**10063**

PASO 11

Atornillar las tuercas 2x**10063**

ÉTAPE 11

Vissez le brunette 2x**10063**

12

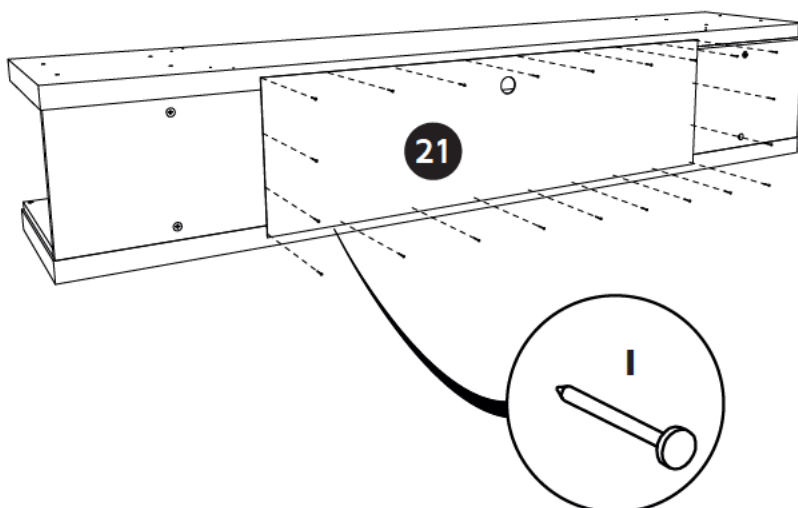

PASSO 12

Encaixar fundo **21**

pregar **0357**

STEP 12

Attach backplate **21**

nailing **0357**

PASO 12

Enganchar el fondo **21**



clavar **0357**

ÉTAPE 12

Insérez le fond **21**

Clouer **0357**

13

D COD. 8471 	G COD. 8056 	H COD. 9333 
--	--	--

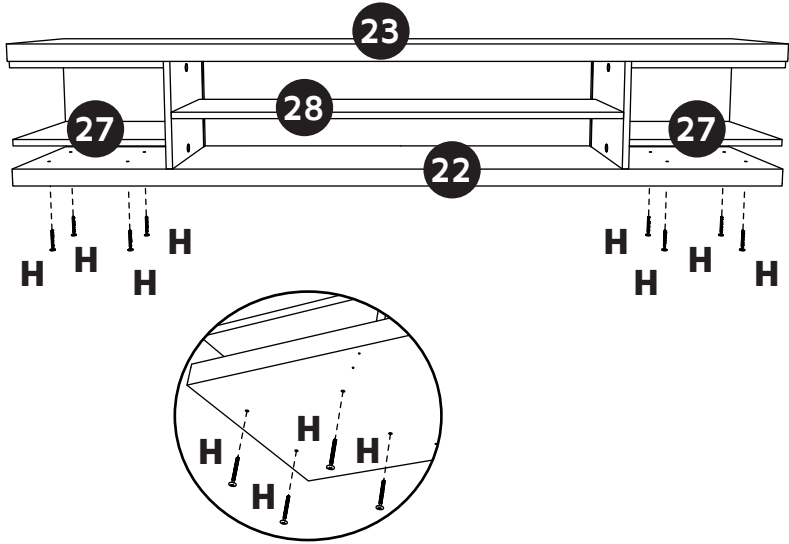

PASSO 13
Encaixar inferior nicho **27**
Parafusar 8x**9333**

STEP 13
Attach bottom niche **27**
Screw 8x**9333**

PASO 13
Montar el fondo nicho **27**
Atornillar 8x**9333**

ÉTAPE 13
Insérez le bas de l'étagère carré **27**
Vissez 8x**9333**

14

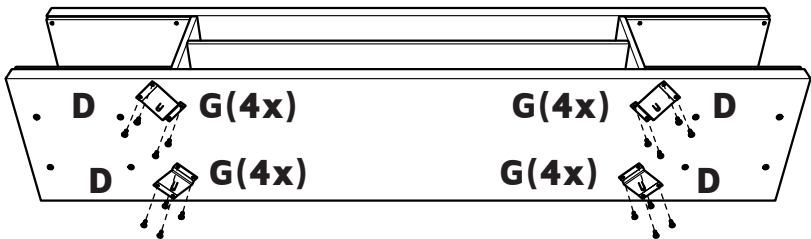

PASSO 14
Encaixar 4x**8471** e parafusar 16x**8056** na base **22**

STEP 14
Attach 4x**8471** and screw 16x**8056** on base **22**

PASO 14
Montar 4x**8471** y atornillar el 16x**8056** en base **22**

ÉTAPE 14
Insérez 4x**8471** et vissez 16x**8056** dans la base **22**

Posicionar usando furo guia.
Place them using pilot hole.
Posicionar usando agujero piloto.
Positionnez à l'aide du trou de guidage.

15

PASSO 15
Encaixar e rosquear 4x pés **50** na base **22**

STEP 15
Attach and screw 4x leg **50** in the base **22**

PASO 15
Montar y atornillar 4x patá **50** en base **22**

ÉTAPE 15
Insérez et visser 4x le pied **50** dans la base **22**

