

Professional Under Cabinet Range Hood

Installation Guide & Users Manual



Model Name: KMJ15S

Available Sizes: 30" 36"

NOTICE:

For residential use only.

Installer: Leave this guide with the homeowner.

Homeowner: Keep this guide for future reference.

Visit: www.itylza.com

Email: support@itylza.com

phone number: +1(213)352-5535



THANK YOU FOR YOUR PURCHASE

Thank you for your purchase. We know that you have many brands and products to choose from and we are honored to know that you have decided to take one of our products into your home and hope that you enjoy it.

We follow the most advanced manufacturing philosophy. Each appliance leaves the factory after thorough quality inspection and testing. We are ready to answer any questions you may have regarding how to install, use and care for your products. We hope that this manual will help you learn to use the product in the safest and most effective manner.

If you have any questions or concerns, please contact our Customer Support at: [**support@itylza.com**](mailto:support@itylza.com)

TABLE OF CONTENTS

Important Safety Notice.....	4
Electrical Requirements.....	6
Venting Requirements.....	7
Calculating Vent System Length.....	8
Specifications.....	8
Required Tools.....	9
Parts Supplied.....	10
Dimensions.....	11
Preparation.....	12
Rough-In.....	13
Installation.....	15
Installation (Filters)	17
Venting Methods.....	18
Back Vent Option.....	19
Wiring Diagram.....	20
Range Hood Operations.....	21
Troubleshooting.....	24
Use and Care Information.....	25
Maintenance.....	26
Bulb Replacement.....	27
Warranty and Service.....	28

IMPORTANT SAFETY NOTICE

Read all instructions before installing and operating this appliance

- The installation in this manual is intended for qualified installers, service technicians or persons with similar qualified background. Installation and electrical wiring must be done by qualified professionals and in accordance with all applicable codes and standards, including fire-rated construction.
- **DO NOT** attempt to install this appliance yourself. Injury could result from installing the unit due to lack of appropriate electrical and technical background.
- Range hood may have very sharp edges; please wear protective gloves if it is necessary to remove any parts for installing, cleaning or servicing.
- Activating any switch ON before completing installation may cause ignition or an explosion.
- Due to the size and weight of this range hood, two-person installation is recommended.

To reduce the risk of fire, electric shock, or injury to persons:

- For general ventilating use only. **DO NOT** use to exhaust hazardous or explosive materials and vapors.
- The combustion air flow needed for safe operation of fuel-burning equipment may be affected by this unit's operation. Follow the heating equipment manufacturer's guideline and safety standards such as those published by the National Fire Protection Association (NFPA), and the American Society of Heating, Refrigeration and Air Conditioning Engineers (ASHRAE), and the local code authorities.
- Before servicing or cleaning unit, switch power OFF at service panel and lock service panel to prevent power from being switched ON accidentally.
- Clean grease laden surfaces frequently. To reduce the risk of fire and to disperse air properly, make sure to vent air outside. **DO NOT** vent exhaust into spaces between walls, crawl spaces, ceiling, attics and/or garages.
- Ducted fans **MUST** always be vented to the outdoors.
- Use only metal ductwork and this unit **MUST** be grounded.
- Sufficient air is needed for proper combustion and exhausting of gases through the duct to prevent back drafting.
- When cutting or drilling into wall or ceiling, be careful not to damage electrical wiring or other hidden utilities.
- All electrical wiring must be properly installed, insulated and grounded.
- Old duct work should be cleaned or replaced if necessary to avoid the possibility of a grease fire.
- Check all joints on duct work to insure proper connection and all joints should be properly taped.
- Use this unit only in the manner intended by the manufacturer. If you have questions, contact the vendor.

To reduce the risk of a stove top grease fire:

- Keep all fans, spacers, filters, grease tunnels, oil containers and grease-laden surfaces clean. Grease should not be allowed to accumulate on fan, baffle, spaces, filter, grease tunnel and oil container.
- Always turn range hood ON when cooking at high heat or when cooking foods that produce flames.
- Use high settings on cooking range only when necessary.
- Never leave surface units unattended at high settings. Boil overs cause smoking and greasy spillovers that may ignite. Heat oils slowly on low or medium settings.

IMPORTANT SAFETY NOTICE

Read all instructions before installing and operating this appliance

- Clean ventilating fan frequently.
- Always use appropriate cookware and utensils size.
- Always use cookware appropriate for the size of the surface element.

To reduce the risk of injury to persons in the event of a stove top grease fire:

- Smother flames with a close-fitting lid, cookie sheet, or metal tray, then turn OFF the burner. Be careful to PREVENT BURNS. Never pick up a pan that has flames—you may be burned. Keep flammable and/or combustible material away from flames. If the flames DO NOT go out immediately, EVACUATE and CALL the FIRE DEPARTMENT or dial your local emergency service immediately.
- DO NOT use WATER, including wet dishcloths or towels — it will result in a violent steam explosion
- Use an extinguisher ONLY if:
 - You know you have a Class A, B, C extinguisher, and you already know how to operate it.
 - The fire is small and contained in the area where it has started.
 - The fire department is on the way.
 - You can fight the fire while having access to a safe exit.

To reduce the risk of injury to persons in the event of a gas leaks:

- Extinguish any open flame.
- DO NOT turn on the range hood fan or any type of ventilator.
- DO NOT turn on the lights or any type of appliance.
- Open all doors and windows to disperse the gas. If you still smell gas, call the gas company and fire department or dial your local emergency service immediately.

Your safety and the safety of others is very important. We have provided many important safety messages in this manual and on your appliance. Always read and obey all safety messages. All safety messages will tell you what the potential hazard is, tell you how to reduce the chance of injury, and tell you what can happen if the instructions are not followed.



WARNING



This is the safety alert symbol. This symbol alerts you to potential hazards that can hurt you and others. All safety messages will follow the safety alert symbol and the word “WARNING”.

The manufacturer and/or distributor/reseller declines all responsibility in the event of failure to observe the instructions given here for installation, maintenance and suitable use of the product.

The manufacturer and/or distributor/reseller further declines all responsibility for injury due to negligence and the warranty of the unit automatically expires due to improper maintenance.

The manufacturer and/or distributor/reseller will not be held responsible for any damages to personal property or real estate or any bodily injuries whether caused directly or indirectly by the range hood.

ELECTRICAL REQUIREMENTS

IMPORTANT: Observe all governing codes and ordinances.

It is the customer's responsibility:

- To contact a qualified electrician
- To assure that the electrical installation is adequate and in conformance with National Electrical Code and all local codes and ordinances.

If codes permit and a separate ground wire is used, it is recommended that a qualified electrician determine that the ground path is adequate.

A 110/120-Volt, 60 Hz, AC-only, fused electrical supply is required on a separate 15-amp circuit.

DO NOT ground to a gas pipe.

Check with a qualified electrician if you are not sure that the range hood is properly grounded.

DO NOT have a fuse in the neutral or ground circuit.

IMPORTANT: Save this Installation Guide for electrical inspector's use.

The range hood must be connected with copper wire/plug only.

The range hood should be connected directly to the fused disconnect (or circuit breaker) box through flexible armored or non-metallic sheathed copper cable. A U.L. - or C.S.A. - listed strain relief must be provided at each end of the power supply cable.

Wire sizes (copper wire only) and connections must conform with the rating of the appliance as specified on the model/serial rating label. Wire sizes must conform to the requirements of the National Electrical Code ANSI/NFPA 70—latest edition*, or CSA Standards C22.

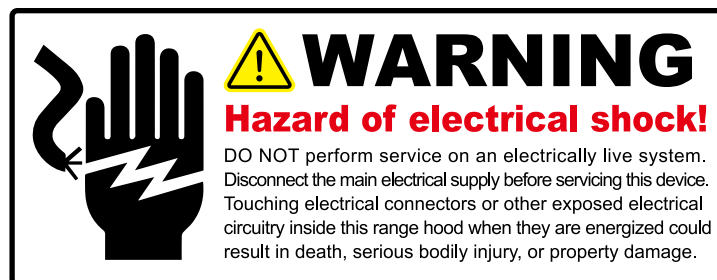

VENTING REQUIREMENTS

- Vent system must terminate to the outside (roof or side wall).
- DO NOT terminate the vent system in an attic or other enclosed area.
- DO NOT use 4" (10.2 cm) laundry-type wall caps.
- Use metal/aluminum vent only. Rigid metal/aluminum vent is recommended.
- DO NOT use plastic vent.
- Always keep the duct clean to ensure proper airflow.
- Calculate the following figures before installation:
 1. *Distance from the floor to the ceiling.*
 2. *Distance between the floor to the countertop/stove (recommend* 24" to 30").*
 3. *Distance between the countertop/stove to the range hood.*
 4. *Height of hood and duct cover.*

For the most efficient & quiet operation:

- A distance of 24" to 30" is recommended between stove top and the bottom of range hood (30" min for 9' ceilings)
- It is recommended that the range hood be vented vertically through the roof through 6" or bigger round metal/aluminum vent work.
- The size of the vent should be uniform.
- Use no more than three 90° elbows.
- Make sure there is a minimum of 24" (61 cm) of straight vent between the elbows if more than one elbow is used.
- DO NOT install two elbows together.
- The length of vent system and number of elbows should be kept to a minimum to provide efficient performance.
- The vent system must have a damper. If roof or wall cap has a damper, DO NOT use damper (if supplied) on top of the range hood.
- Use aluminum tape to seal all joints in the vent system.
- Use caulking to seal exterior wall or roof opening around the cap. **USE 6" ROOF OR WALL VENT CAP MINIMUM.**

IMPORTANT:

- A minimum of a 6" round duct (standard for this range hood) must be used to maintain maximum airflow efficiency.
- Always use rigid type metal/aluminum ducts if available to maximize airflow when connecting to provided duct.
- Please use Duct Run Calculation below to compute total available duct run when using elbows, transitions and caps.
- ALWAYS, when possible, reduce the number or transitions and turns in the duct run. If a long duct run is required, increase the duct size from 6" to 8". If a reducer is used, install a long reducer instead of a pancake reducer. Reducing the duct size will restrict airflow and decrease efficiency.
- If turns or transitions are required: Install as far away from opening and as far apart, between 2, as possible.
- Minimum mount height between stove top to hood bottom should be no less than 24-inch*.
- Maximum mount height between stove top to hood bottom should be no higher than 30-inch*.
- It is important to install the hood at the proper mounting height. Hoods mounted too low could result in heat damage and fire hazard; while hoods mounted too high will be hard to reach and will lose its performance and efficiency.
- If available, also refer to stove top manufacturer's height clearance requirements and recommended hood mounting height above range.

Minimum Duct Size:

- Round - 6" minimum

CALCULATING VENT SYSTEM LENGTH

To calculate the length of the duct system you require, subtract the equivalent feet for each “Vent piece” (Table Below) used in the system from the “Recommended maximum run” (Table Below). The longest duct run that is acceptable (if completely straight) is 50 feet. The number of vent pieces (elbow, transition, etc.) installed in your duct run will determine the maximum length the duct run can be. Please refer to the example below:

Duct Run Calculation:	
Recommended maximum run	
6” round duct	50 ft
Vent piece deduction	
Each 90° elbow used	9 ft
Each 45° elbow used	5 ft
Each 6” to 3/14 x 10” transition used	7 ft
Side wall cap with damper	7 ft
Roof cap	7 ft

Duct Run Calculation example:

One roof cap, two 90° elbows, and one 45° elbow used:

7ft + 9ft + 9ft + 5ft = 30ft used.

The above vent pieces used are equivalent to 30ft of a straight duct run. Subtract 30ft from the allowable 50ft. The remaining distance of 20ft is the longest that the straight ducting (in addition to the vent pieces) can be.

SPECIFICATIONS*

Body	Stainless Steel / Sheet Metal+Toughened glass
Power Rating	110-120V/60Hz (USA & Canada standard)
General Input Power	256W+# of Light x Voltage of Light
Motor Input Power	250W
Motor Revolution	800 RPM (±10%) to 1300 RPM (±10%)
Levels Of Speed Control	4 Levels
Maximum Airflow	900 CFM
Air Pressure	150 Pa (200 Pa Maximum)
Noise Level (dB / sone)	Approximately 23.5 / 0.4 to 60 / 7.0 (Lowest to highest Speed)
Control Type	Gesture / Touch / Infrared Remote Control
Illumination	LED 3W 12V
Venting Size	Top Vent, 6 inch Round

REQUIRED TOOLS

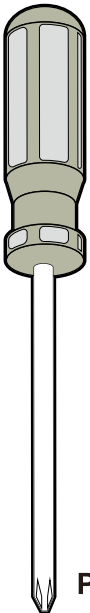

Phillips Screwdriver

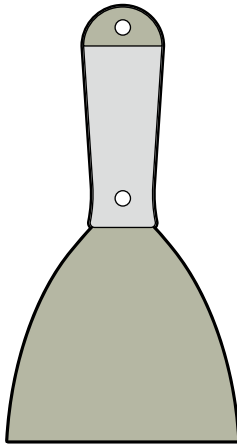

Putty Knife

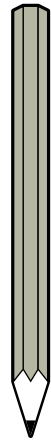

Marker or Pencil

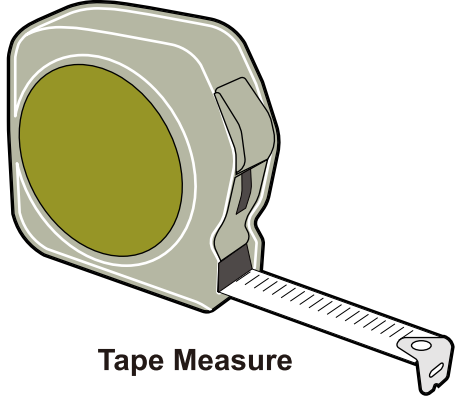

Tape Measure

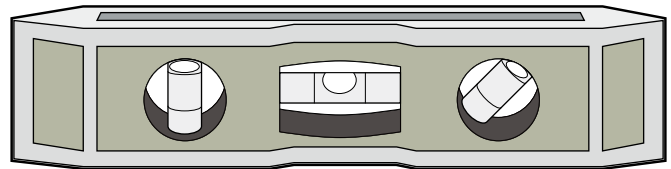

Level

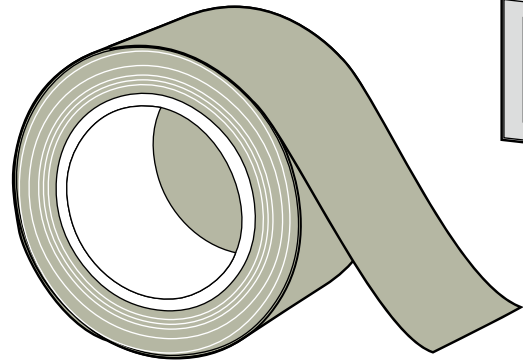

Aluminum Tape

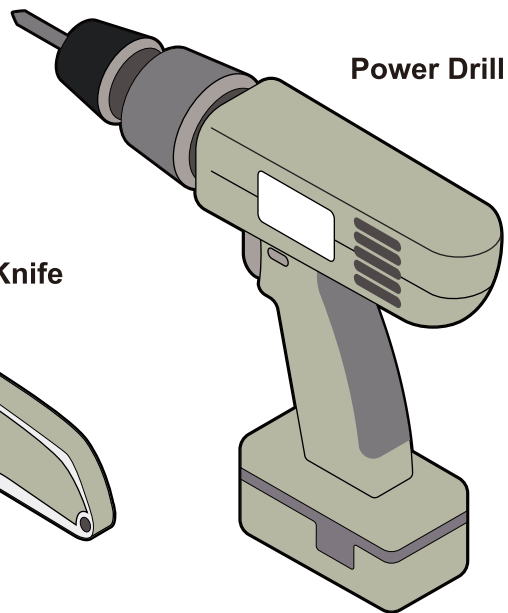

Power Drill

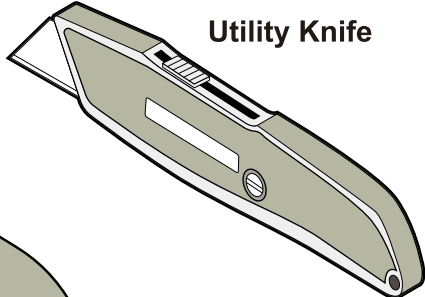

Utility Knife

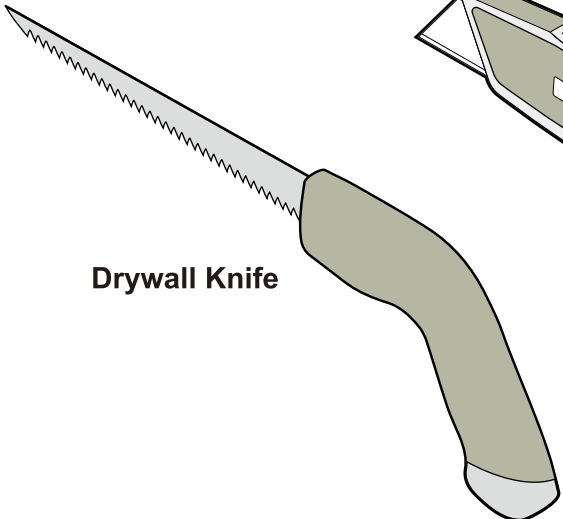

Drywall Knife

PARTS SUPPLIED

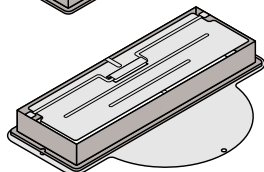
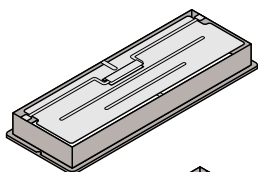

Includes Rectangular 9 3/4" x 3 1/4" Exhaust Connector option (with plate adaptor)



Wood screw
(x12)



Anchor
Screw
(x12)



Self-Drilling
Plastic
Drywall
Anchor
(x12)

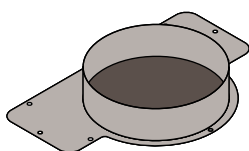

Includes 6"- Ø Round Transition option

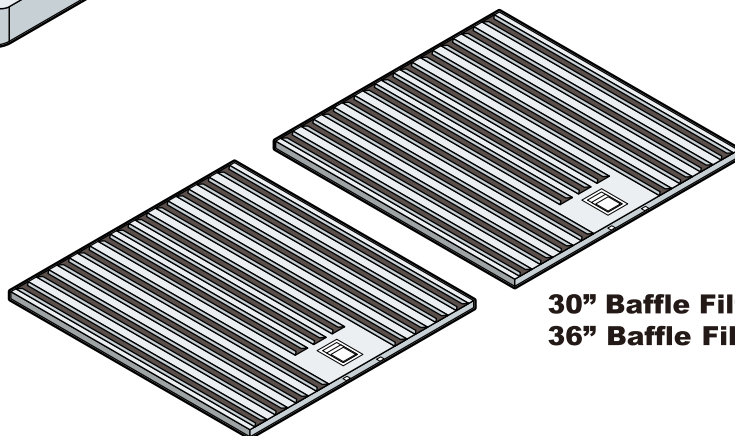
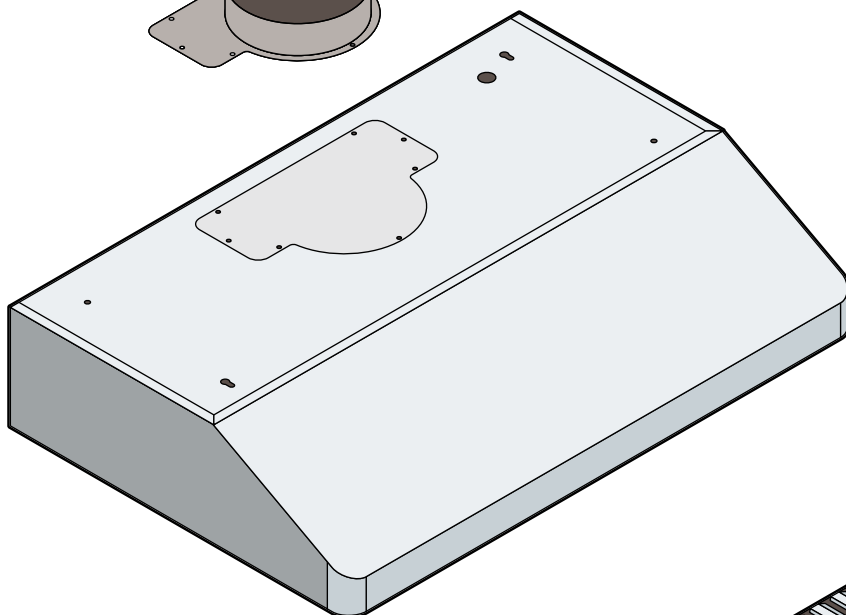

30" Baffle Filters (x2)
36" Baffle Filters (x3)

NOTE:

Where necessary, additional screws will be needed for installation and added support, but is not included. Please review contents before installation.

DIMENSIONS

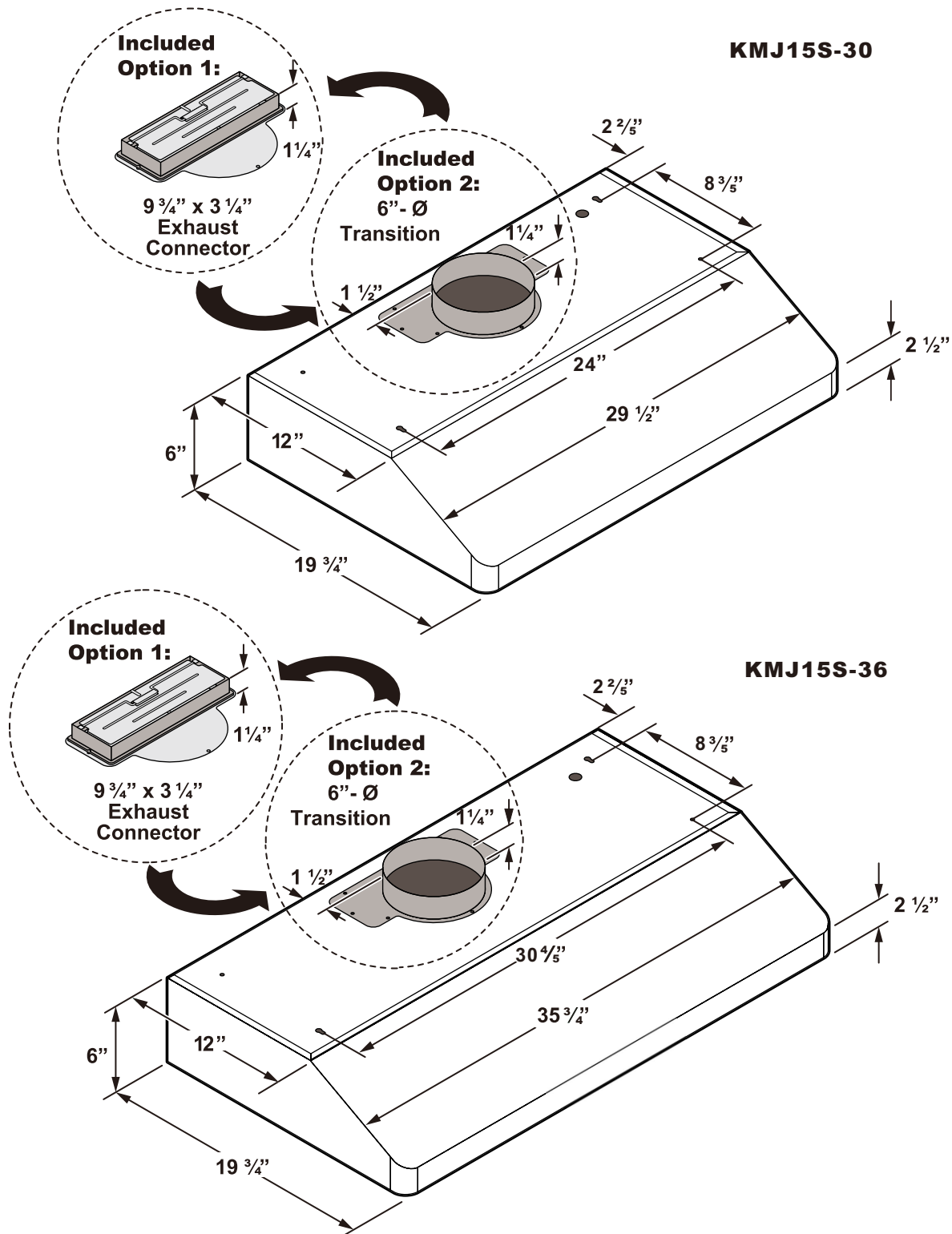

PREPARATION



WARNING

Severe Injury

Hood may have very sharp edges. Please wear protective gloves if it is necessary to remove any parts for installing, cleaning or servicing.



WARNING

Excessive Weight

Require three or more persons to move and install this range hood. Spinal or other bodily injuries could occur if it is not followed.

**BEFORE INSTALLING THE RANGE HOOD, CHECK FOR PHYSICAL DAMAGES.
THIS RANGE HOODS COMES WITH A WIRE AND PLUG.
TEST THE HOOD BEFORE INSTALLATION.**

If there is a grinding noise coming from the motor, **DO NOT INSTALL IT**, contact us as soon as possible.

Advanced Preparations:

1. Read the entire installation guide and users manual thoroughly, understand instructions and warnings.
2. Be familiar with the controls of the range hood.
3. Place the range hood on a flat, stable surface. Connect the range hood to a designated standard outlet (please refer the product label for the suitable voltage of this unit) and verify no debris has entered the duct openings, then turn on the range hood.
4. Place all supplied parts and required hardware on a flat, stable surface and verify the existence of all supplied parts.
5. Carefully remove the white/blue plastic protective coat from the chimney covers and range hood if any.

Preparations:

NOTE: To avoid damage to your hood, prevent debris from entering the duct opening.

1. Determine and mark the center line on the ceiling where the range hood will be installed. Make sure there is proper clearance within the ceiling or wall for exhaust duct.
2. Due to the weight and size of this unit, please make sure that the support system or framework being used is stable and secure in the ceiling.
3. Put a thick, protective covering over counter top, cook top or range to protect from damage or dirt. Remove any hazardous objects around the area when installing.
4. Mark the locations of the support mounting bracket holes, vent cutout (if used) and power supply cable cutout on the ceiling. Use drill and saber saw or keyhole saw to cut openings for power supply cable and duct.
5. Use caulking to seal exterior wall or roof openings.
6. Disconnect main electrical supply, prepare and run electrical wiring through ceiling. Leave approximately 12" of electrical cord hanging from the ceiling. Do not restore power until wiring is completed.
7. Disconnect power cord, remove the stainless steel baffle filter and grease tunnel.
8. Set aside the stainless steel baffle filters and grease tunnel until the range hood is properly installed.

ROUGH-IN

FRONT VIEW

(1) Measure the distance between the stove top and the bottom of range hood. A distance of 24" to 30" is recommended*.

**Due to different ceiling height configurations, recommended height may not be applicable.*

Preferred areas to install wall or roof vent ducting.

Wall or roof vent may be installed in these areas but not recommended.

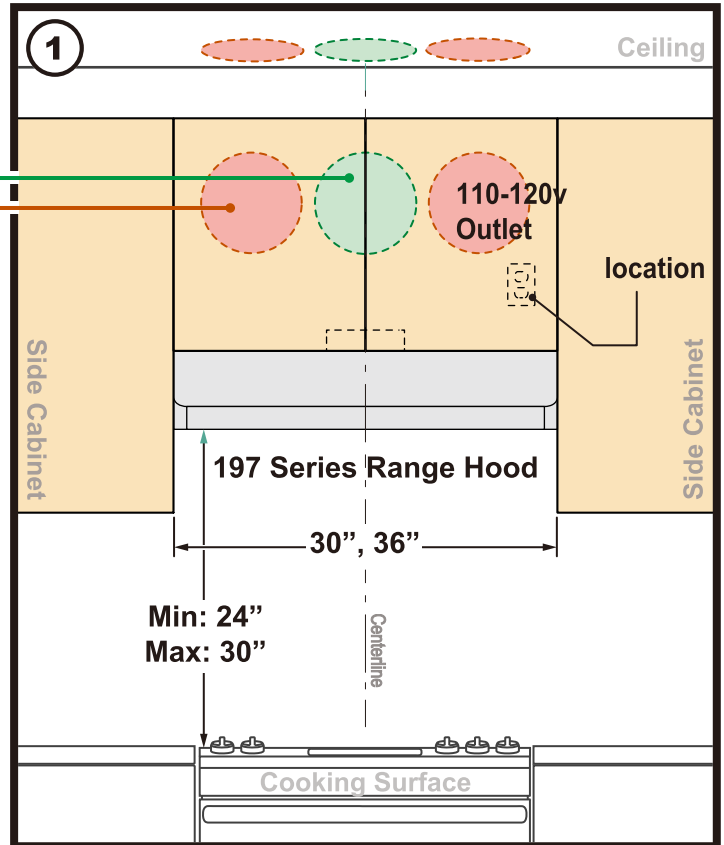

WARNING
Hazard of electrical shock!
DO NOT perform service on an electrically live system. Disconnect the main electrical supply before servicing this device. Touching electrical connectors or other exposed electrical circuitry inside this range hood when they are energized could result in death, serious bodily injury, or property damage.



WARNING
Severe Injury
Rotating fan can cause severe injury. Stay clear of fan when motor is running.

SAFETY WARNING: Risk of electrical shock. this range hood must be properly grounded. Make sure this is done by qualified electrician in accordance with all applicable national and local electrical codes. Before connecting wires, switch power off at service panel and lock service panel to prevent power from being switched on accidentally.

ROUGH-IN (Continued)

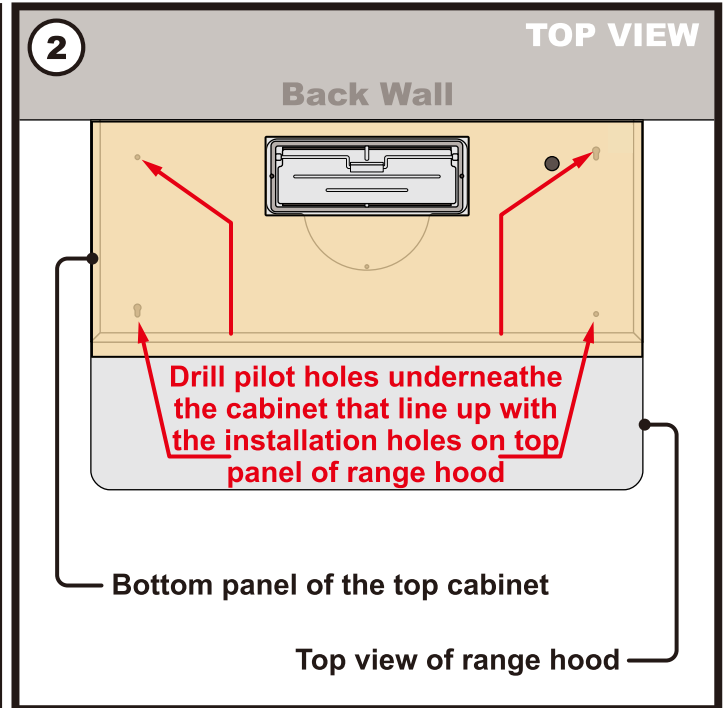
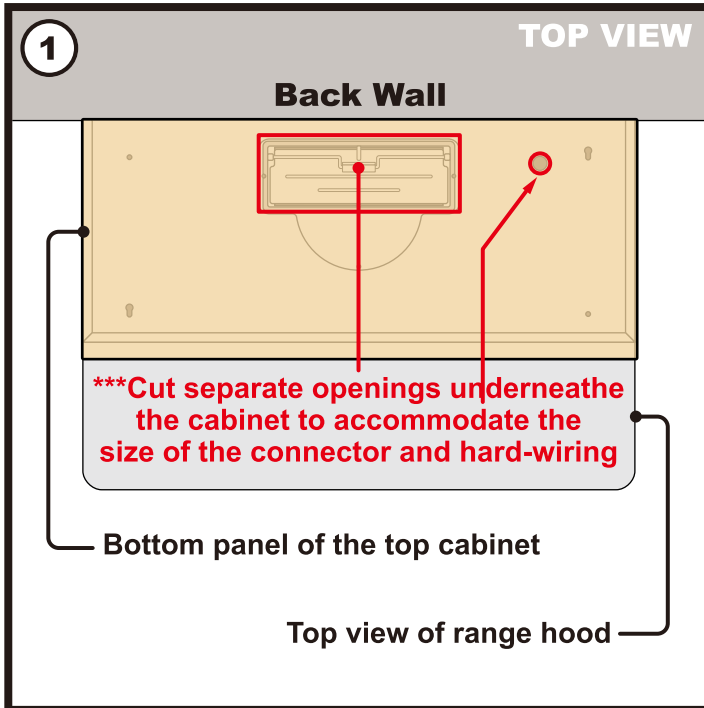

******* Ensure you have $\frac{7}{8}$ " space from wall to your cut out to accommodate the size of connector for ducting.

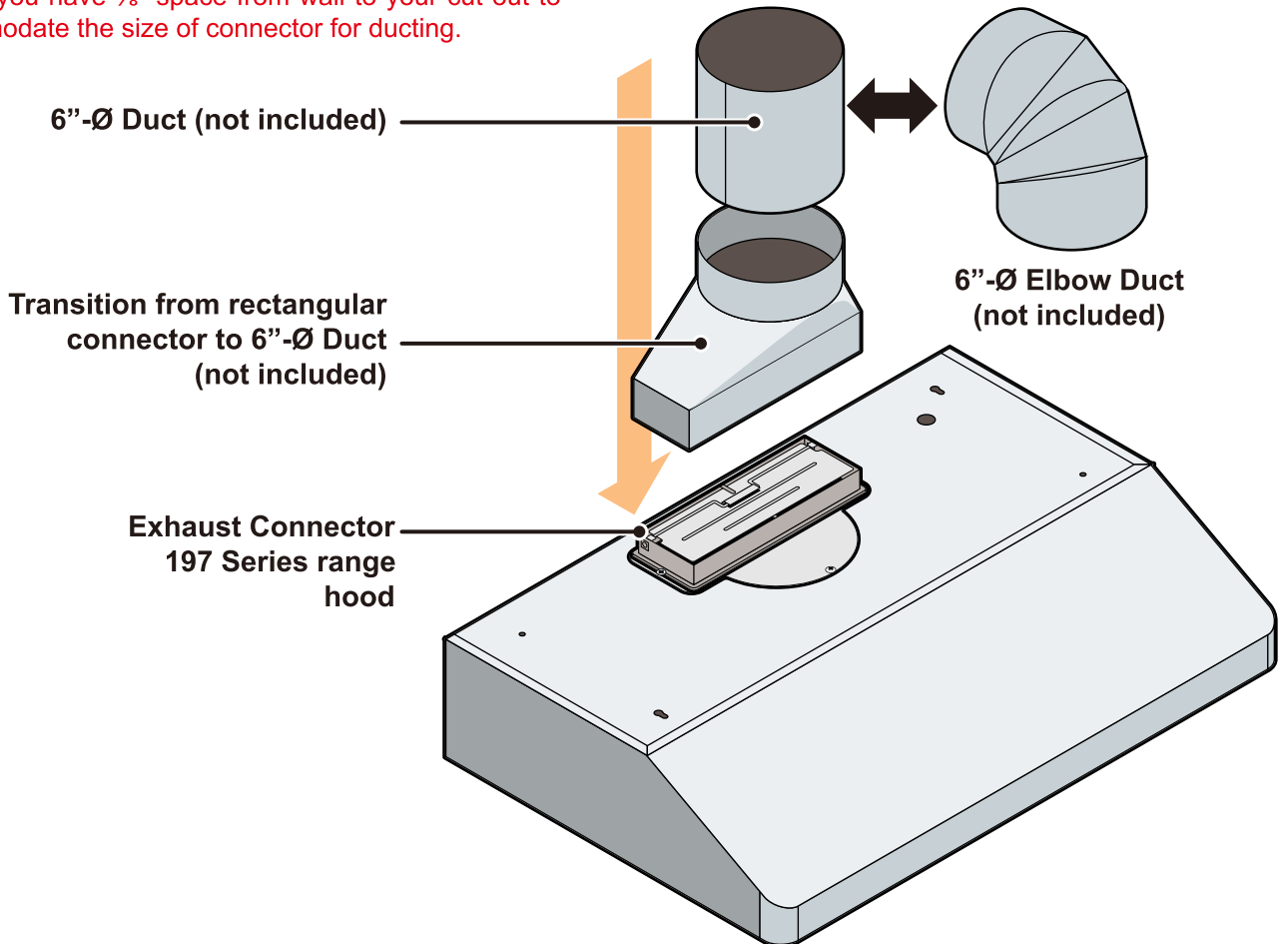

INSTALLATION OPTION 1

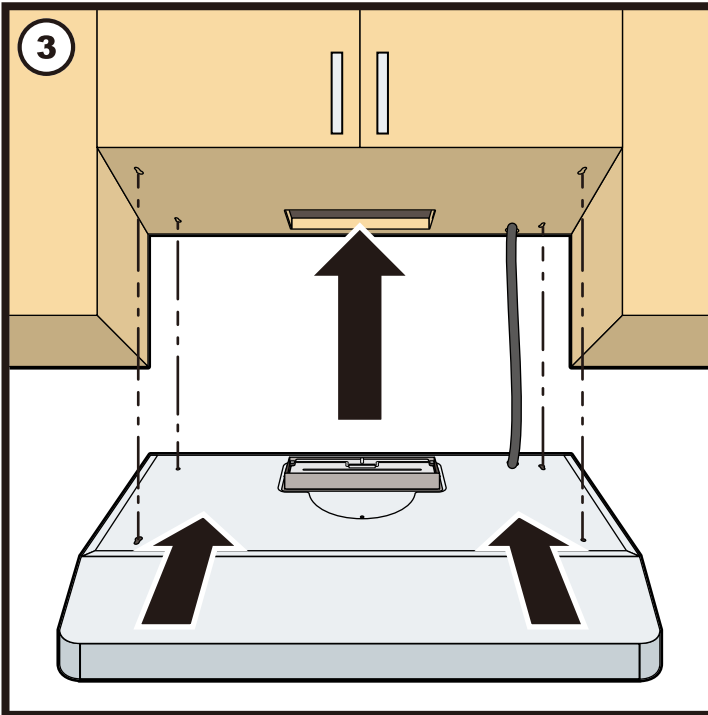

(3) Lift and insert the range hood underneath the cabinet. Ensure the wiring passes through the opening created below the cabinet.

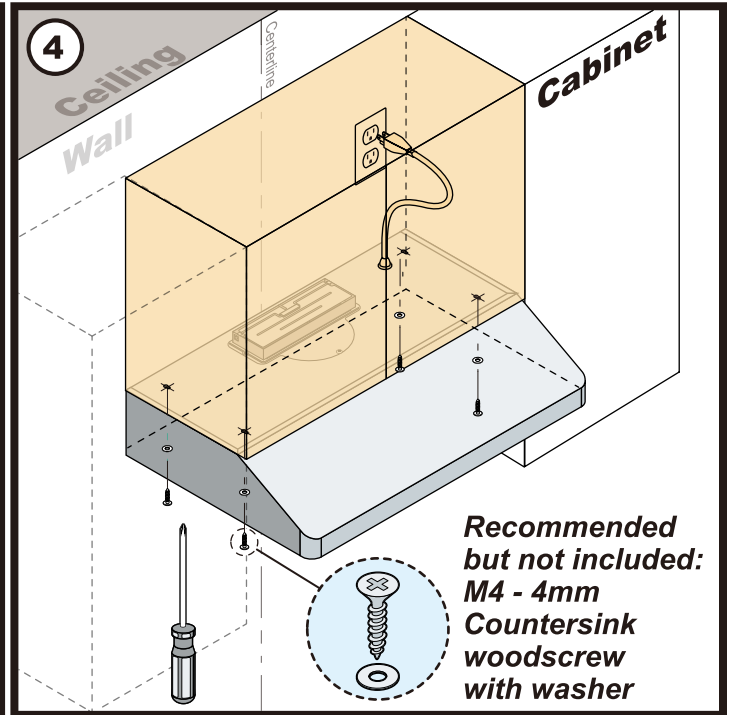

(4) Secure with 4 woodscrews from the inner side of the range hood.

CAUTION: Make certain the range hood is secure before releasing!

Connect the range hood's electrical wiring and check the fan motor and lights are functioning. **Be alert of any electrical hazards and refer to the product label for the suitable voltage of this unit.**



WARNING
Hazard of electrical shock!
DO NOT perform service on an electrically live system. Disconnect the main electrical supply before servicing this device. Touching electrical connectors or other exposed electrical circuitry inside this range hood when they are energized could result in death, serious bodily injury, or property damage.



WARNING
Severe Injury
Rotating fan can cause severe injury. Stay clear of fan when motor is running.

INSTALLATION OPTION 1 (continued)

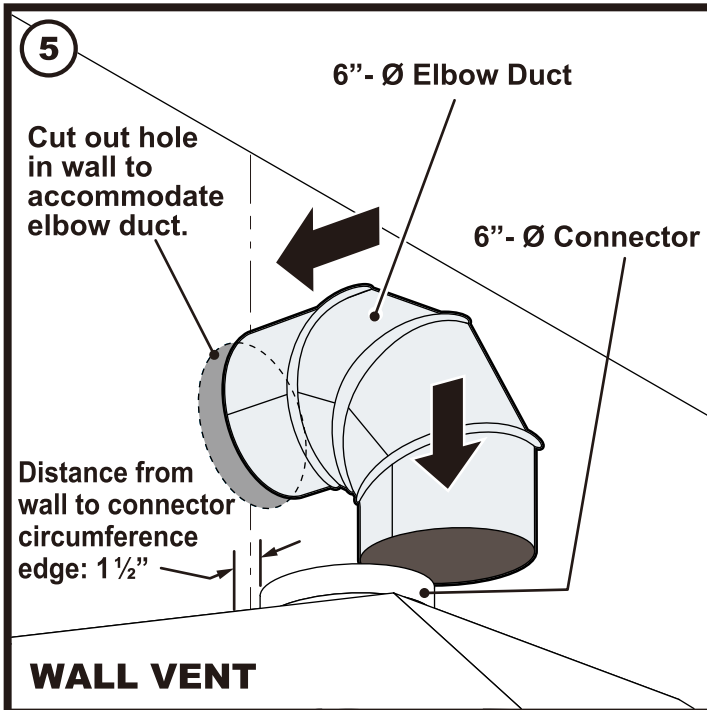

Distance from wall to transition circumference edge for 6" - Ø Transition will be 1 1/2".

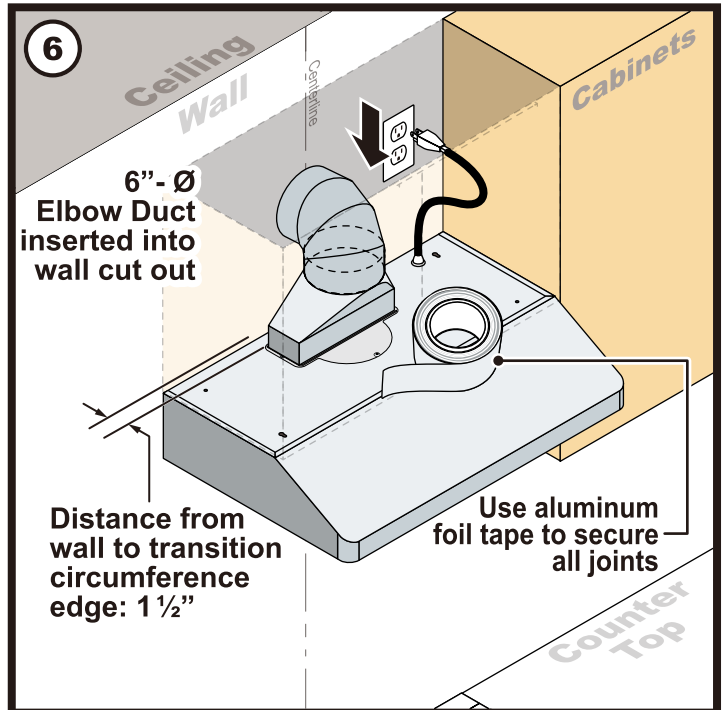

Use aluminum foil tape to make all joints secure and air tight.

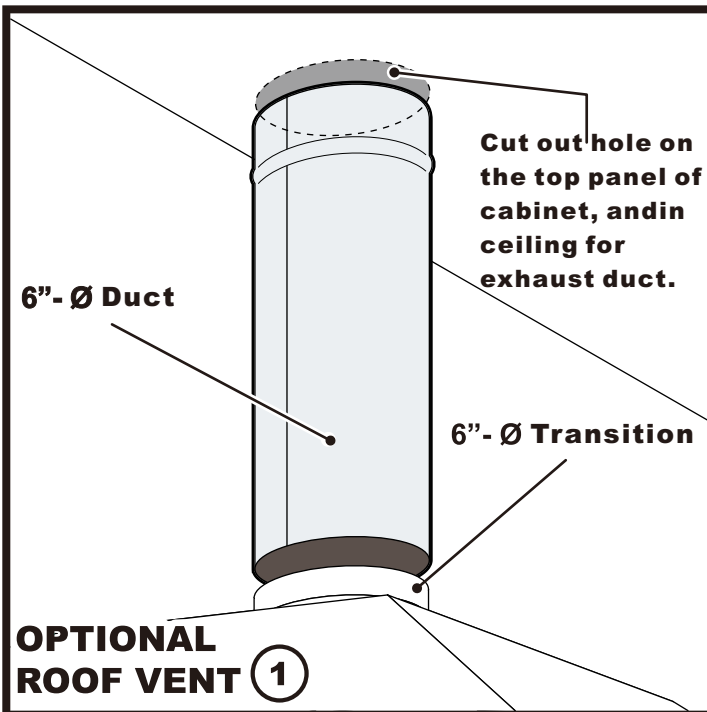

Use 6" round steel pipe to connect the exhaust on the hood to the ductwork above. Use aluminum foil tape to make all joints secure and air tight.

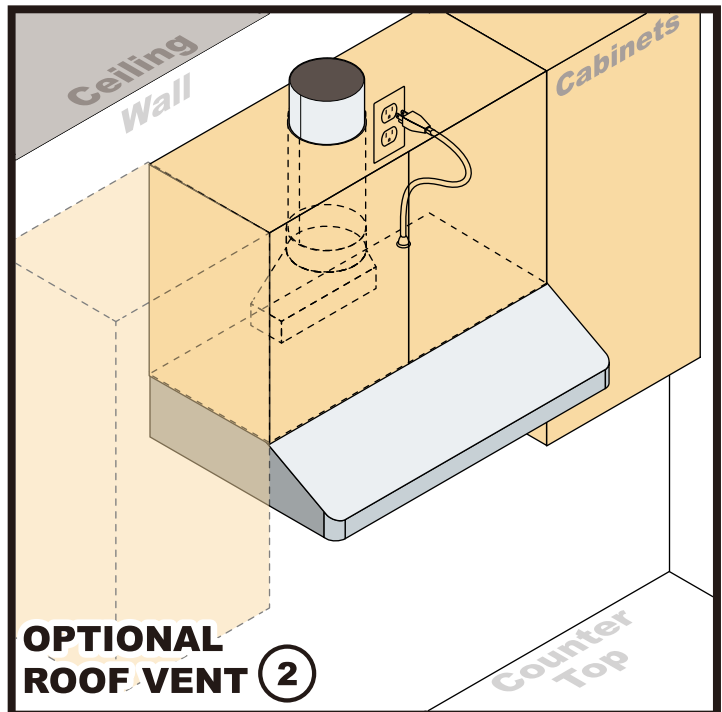

Ensure the cylinder duct passes through, leading to the roof cut out for exhaust connecting duct.

INSTALLATION OF FILTERS

BOTTOM VIEW

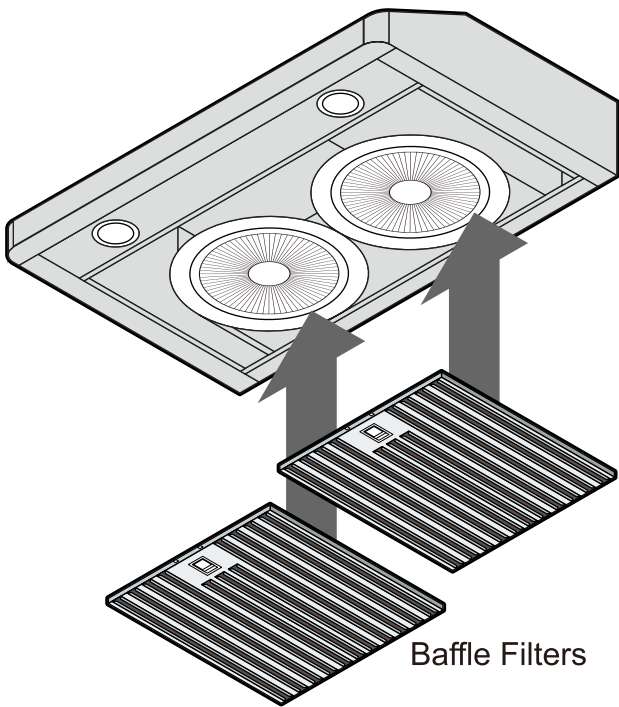

Baffle Filters

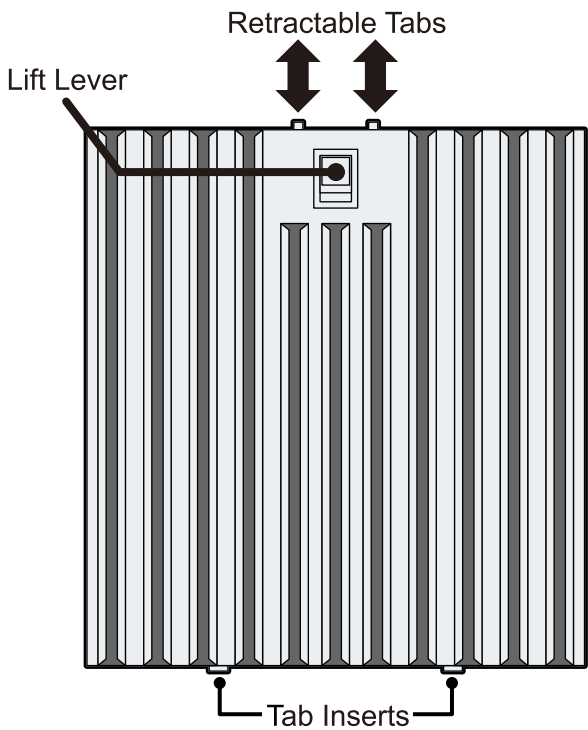

Retractable Tabs

Lift Lever

Tab Inserts

SIDE VIEW

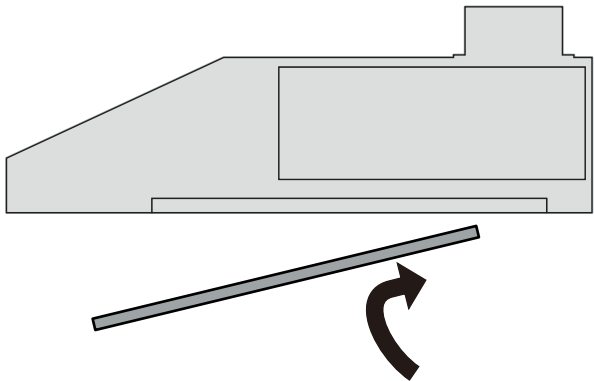

Angle filter and direct tab inserts toward the aft slot of the range hood opening.

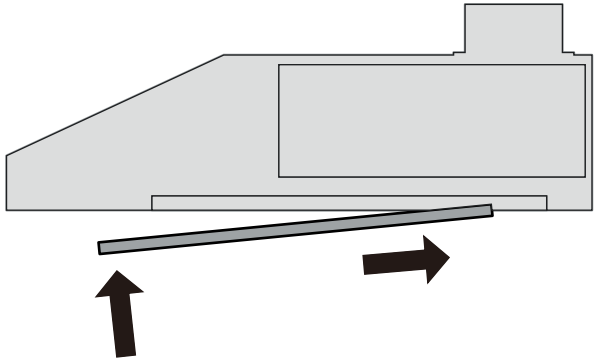

While continuing to install the filter, ensure you lift the lever for the retractable tabs to clear way for flush insertion.

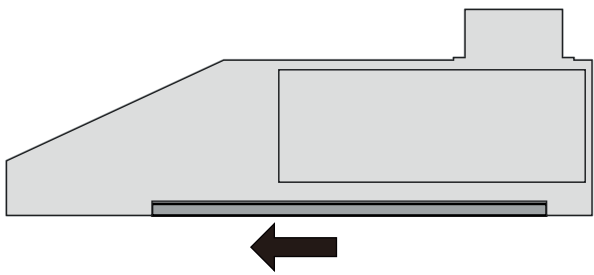

When filter sits flush within the opening, release the lever to lock in place.

VENTING METHODS

- This range hood is factory set for venting through the roof or wall.
- Duct work can terminate either through the roof or wall. To vent through a wall, a 90° elbow is needed.

IMPORTANT:

- NEVER exhaust air or terminate duct work into spaces between walls, crawl spaces, ceiling, attics or garages. All exhaust must be vented to the outside.
- Use metal/aluminum duct work only.
- Fasten all connections with sheet metal screws and tape all joints with certified Aluminum Tape.
- Use caulking to seal exterior wall or roof opening around the cap.
- Colder climates require wrapping insulation around the ducts and optional blowers.
- The system must have a Backdraft Damper.

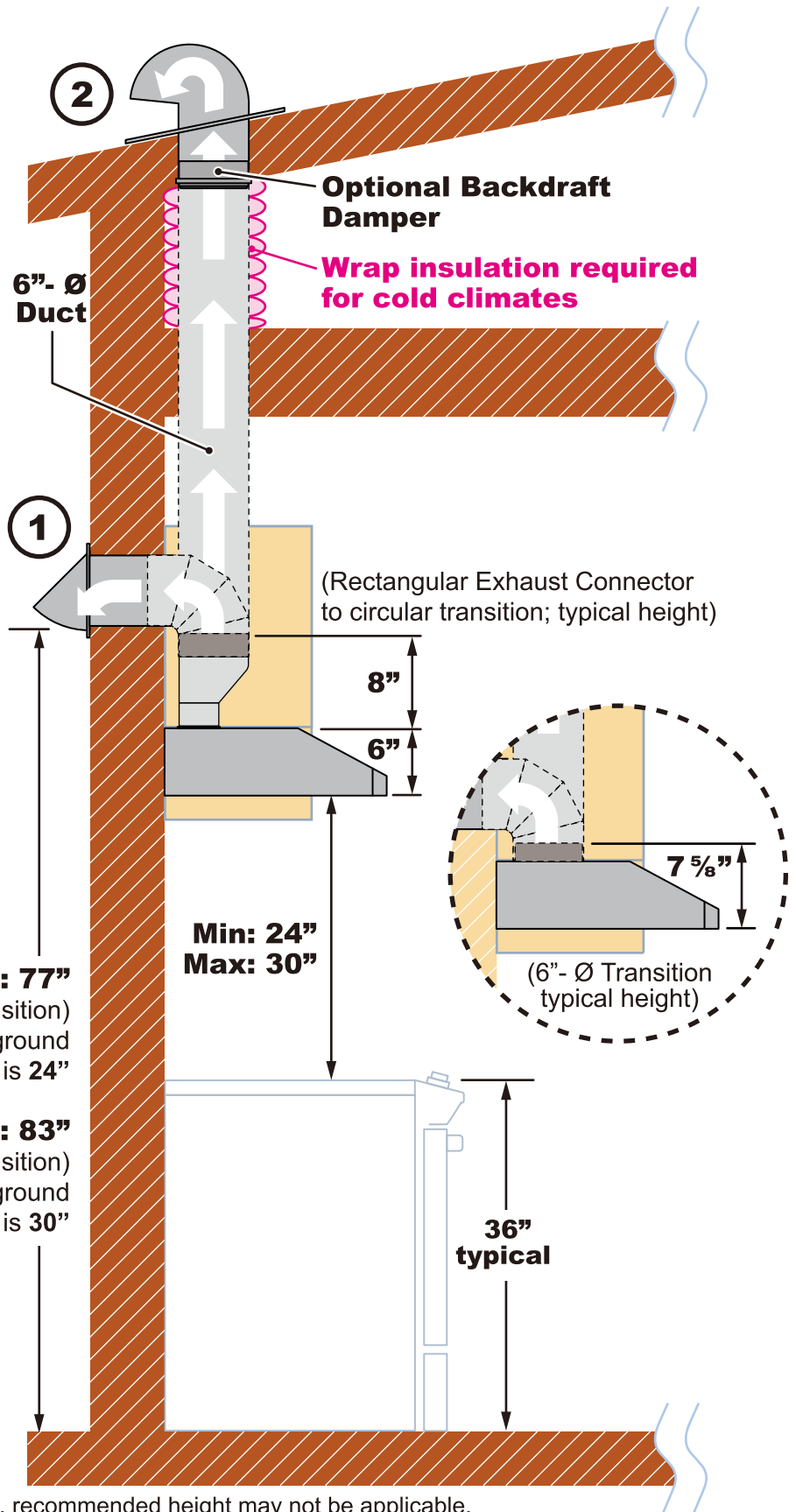

*** Minimum height: 77"**
(70 5/8" for 6"- Ø Transition)
 from bottom of duct to ground
 when range height to stove is 24"

Min height: 83"
(76 5/8" for 6"- Ø Transition)
 from bottom of duct to ground
 when range height to stove is 30"

- ① Wall Vent
- ② Roof Vent

* Due to different ceiling height configurations, recommended height may not be applicable.

BACK VENT OPTION

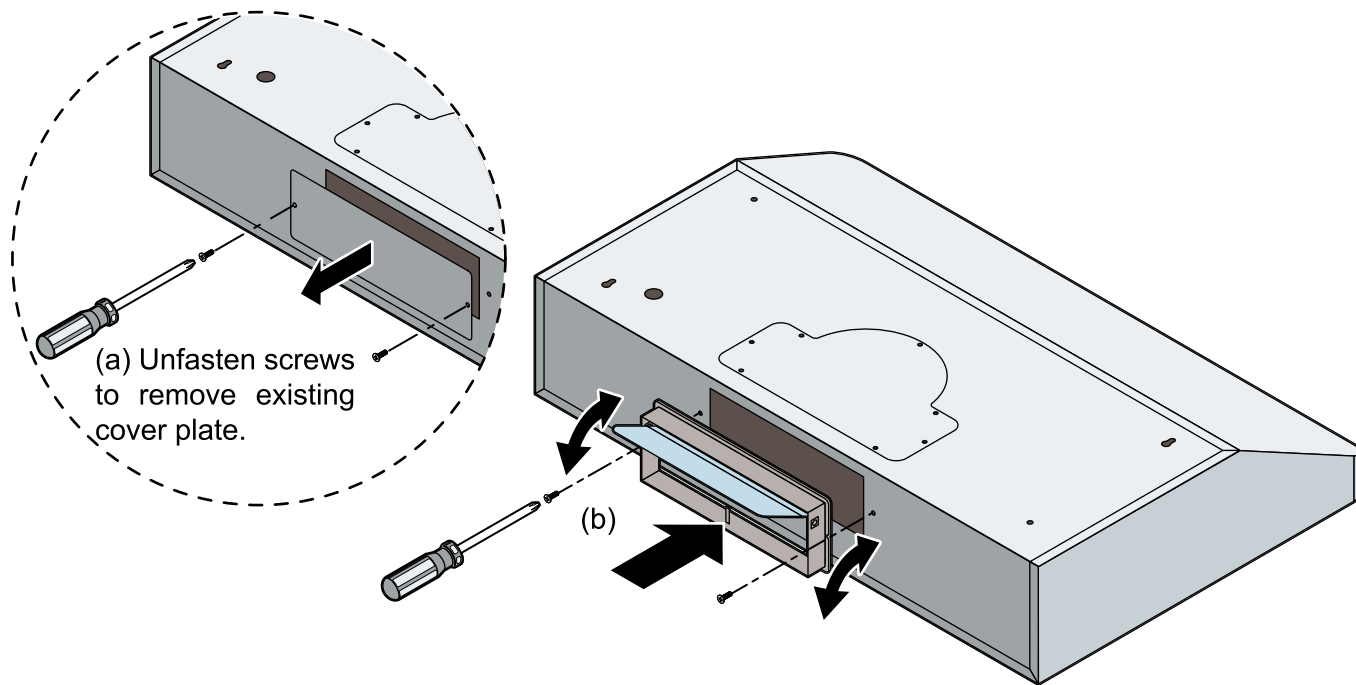
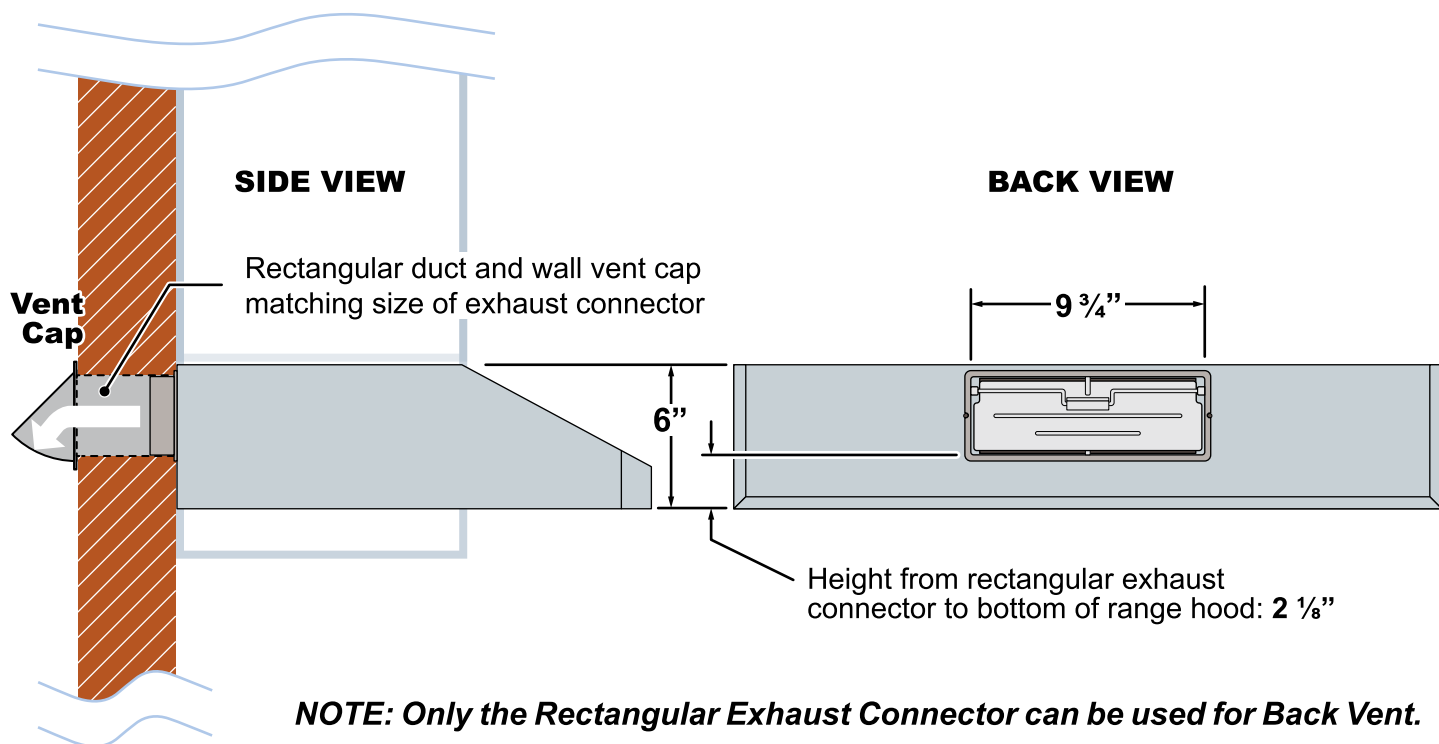

(b) Fasten the exhaust connector (using the existing screws from the cover plate) at the back of the range hood and ensure that the damper (flap) hinge is at the top.

NOTE: Remove damper (flap) if you will be using a roof or wall cap that already has a built-in damper included.

WIRING DIAGRAM

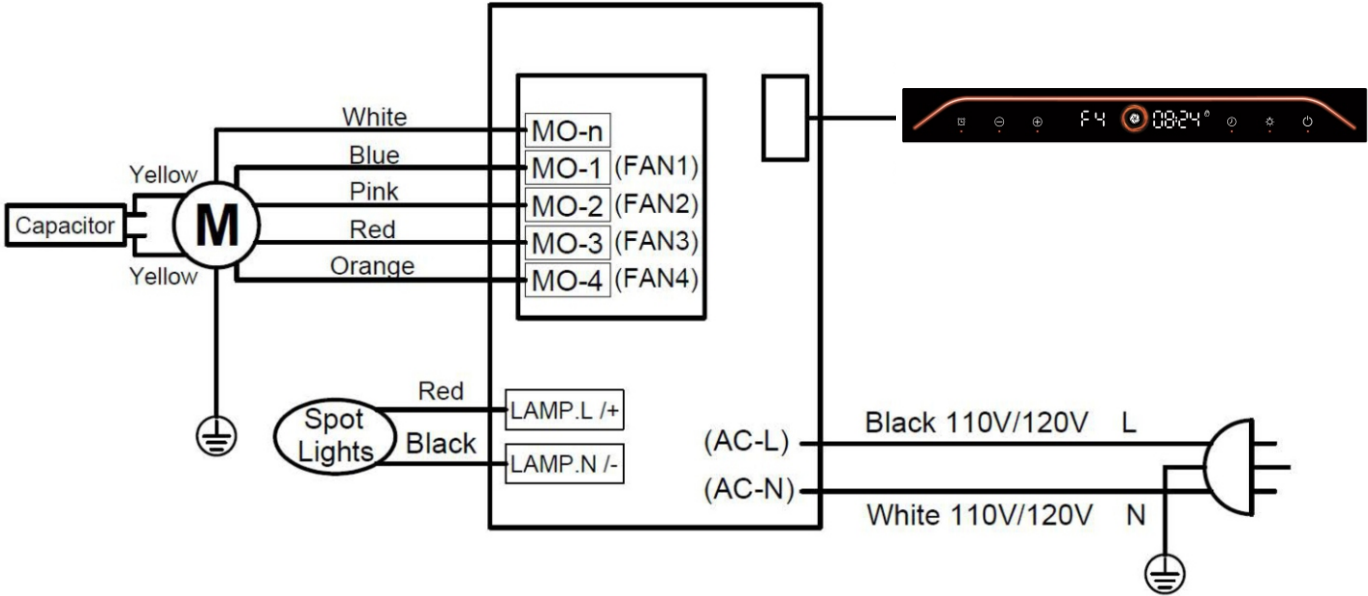

RANGE HOOD OPERATIONS





- A.  Power: tap to turn on the range hood (hold for 3 seconds will turn on/off the motion-sensitive control).

Note: you can only turn on/off the motion-sensitive control at the standby mode!

- B.  Light: tap to turn on/off the lights (press and hold this button can adjust the brightness of the LED bulbs).

- C.  Delay shutdown: tap to turn off the fan automatically after 3 minute.

- D.  Plus Button: first touch will run the 1st speed F1, and then increase the settings.

- E.  Minus Button: first touch will run the 4th speed F4, and then decrease the settings (hold for 3 seconds will turn on/off the voice control sensor.)









Note: you can only turn on/off the voice control when the fan is turned off.

- F.  Timer: only works when the range hood fan is running, touch once, the timer has a default setting of 15 minutes, the fan will shutdown after 15 minutes; use the minus or plus button to decrease or increase the time duration optionally.

RANGE HOOD OPERATIONS

How to set the clock (12-Hour Time):

Note: you can only set the clock when the fan is turned off.

1. Tap the power icon  to turn on the switch control panel, hold the delay shutdown button  for 3 seconds, the hours will blink, use the minus  or plus button  to set the hour.
2. Tap the delay shutdown button  again to switch to the minutes setting, use the minus  or plus  button to set the minutes.
3. Tap the delay shutdown button  to finish the clock setting (Note: you will need to reset the clock if the power supply was cut off).

Motion-sensitive Control:

The operating distance for motion-sensitive control is around 8 to 10cm (3 - 4 inches) from the control panel. This range allows the sensors to detect your hand movements effectively without being too sensitive to accidental motions or too far for accurate detection.

- 1) Wave your hand from Left to Right to increase the fan speed.
- 2) Wave your hand from Right to Left to decrease the fan speed.
- 3) The first wave of your hand from Left to Right, run the 1st fan speed - F1.
- 4) The first wave of your hand from Right to Left, run the 4th fan speed - F4.
- 5) When the fan speed is at F4, wave your hand from Left to Right can turn off the fan.

RANGE HOOD OPERATIONS

Remote control:

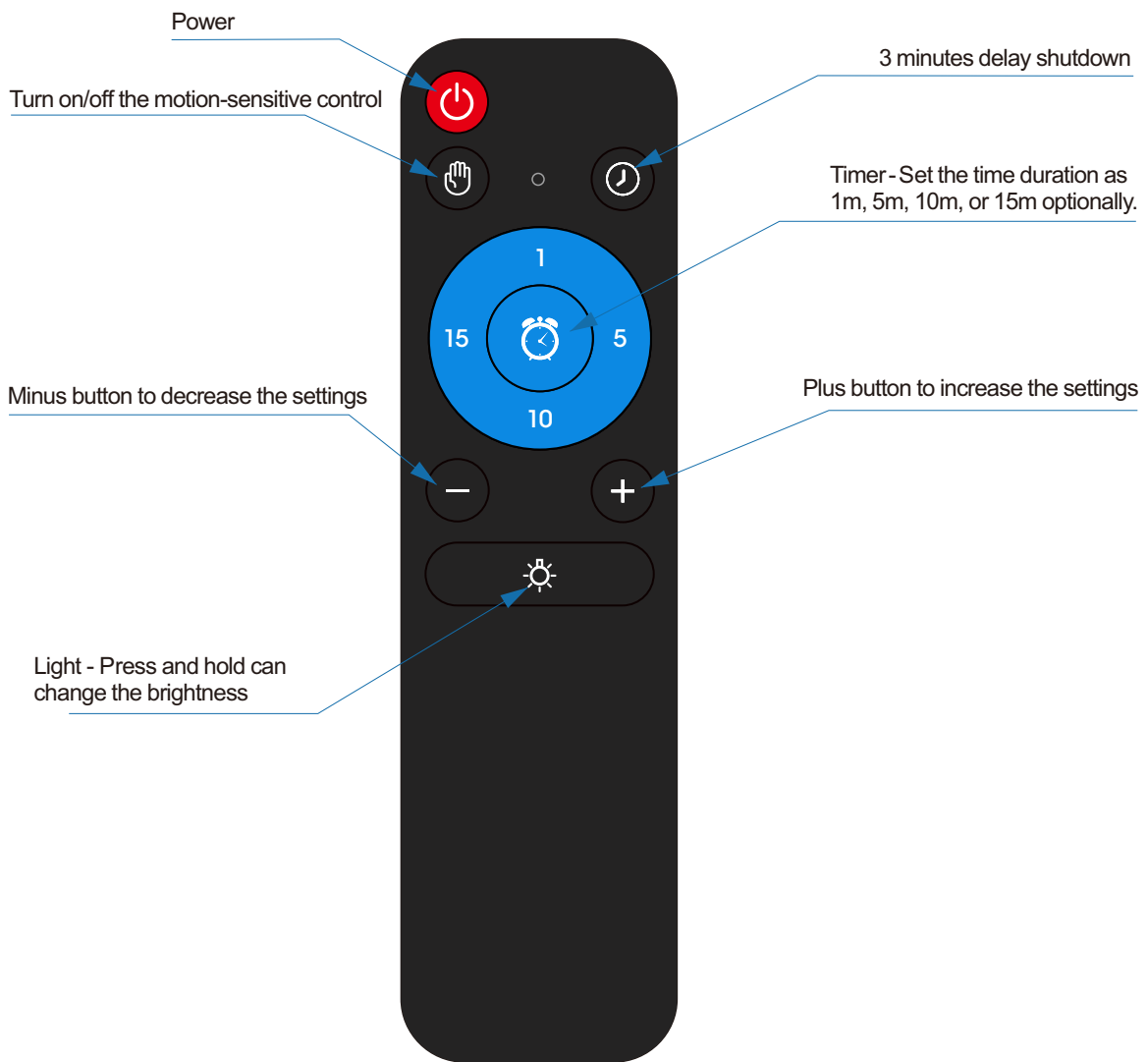

TROUBLESHOOTING

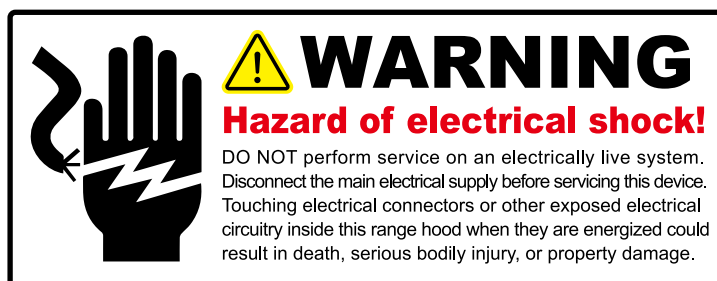

<p>1. If the range hood or lights do not operate after installation:</p>	<ul style="list-style-type: none">• Check if the range hood has been plugged in, make sure that all power has been turned ON, fused not blown and all electrical wiring are properly connected.• Swap out light assembly to working ones to determine whether it is caused by defective bulbs. <i>See Replacing the light bulbs page.</i>
<p>2. The range hood vibrates when the blower is on:</p>	<ul style="list-style-type: none">• The range hood might not have been secured properly on to the ceiling or wall.
<p>3. The blower or fan seems weak:</p>	<ul style="list-style-type: none">• Duct is too small. Range hood WILL NOT function efficiently with insufficient duct size. For example: Connecting this hood to 4", or 5" duct will reduce the suction and create extra noise and vibrations. Check if duct is clogged or if damper unit is not installed correctly or opening properly. A tight mesh on a side wall cap unit might also cause restriction to the air flow.
<p>4. The lights work but the blower is not spinning at all, is stuck or is rattling.</p>	<ul style="list-style-type: none">• The blower might be jammed or scraping the bottom due to shipping damage. Please contact us immediately.
<p>5. The hood is not venting out properly:</p>	<ul style="list-style-type: none">• Make sure the distance between the stove top and the bottom of the hood is within* 24" and 30" in distance. <i>*Due to different ceiling height configurations, recommended height may not be applicable.</i>• Reduce the number of elbows and length of duct work. Check if all joints are properly connected, sealed, and taped.• Make sure the power is on high speed for heavy cooking.

USE AND CARE INFORMATION

Operations:

- Read and understand all instructions and warnings in this manual before operating the appliance. Save these instructions for future reference.
- Always leave safety grills and filters in place. Without these components, operating blowers could catch on to hair, fingers and loose clothing.
- NEVER dispose cigarette ashes, ignitable substances, or any foreign objects into blowers.
- NEVER leave cooking unattended. When frying, oil in the pan can easily overheat and catch fire. The risk of self combustion is higher when the oil has been used several times.
- NEVER cook on “open” flames under the range hood. Check deep-fryers during use: Superheated oil may be flammable.

Cleaning:

- The saturation of greasy residue in the blower and filters may cause increased inflammability. Keep unit clean and free of grease and residue build-up at all times to prevent possible fires.
- Filters must be cleaned periodically and free from accumulation of cooking residue. Old and worn filters must be replaced immediately.
- DO NOT operate blowers when filters are removed. Never disassemble parts to clean without proper instructions. Disassembly is recommended to be performed by qualified personnel only. Read and understand all instructions and warnings in this manual before proceeding.

DO'S AND DON'TS FOR DUCT VENTING

- a. Avoid the use of sharp elbows. Use 45 degrees instead, if possible.
- b. DO NOT use REDUCERS. Keep the size of the duct the same, as per the manual. A reducer will reduce the CFM of the hood and increase the noise.
- c. DO NOT use plenum boxes. Boxes create turbulence and make the hood inefficient. Use a smooth elbow to guide the air outdoors.

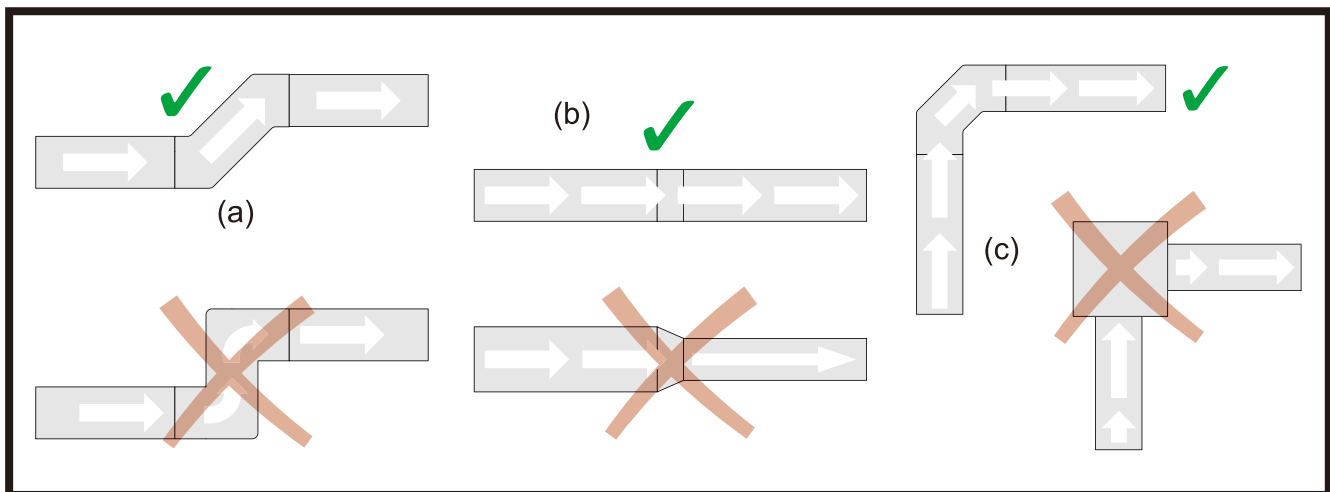

MAINTENANCE

SAFETY WARNING: Never put your hand into area housing the fan while the fan is operating!

For optimal operation, clean range hood and all baffle/spacer/filter/grease tunnel/oil container regularly. Regular care will help preserve the appearance of the range hood.

Cleaning Exterior surfaces:

- Clean periodically with hot soapy water and clean cotton cloth. Do not use corrosive or abrasive detergent (e.g. Comet Power Scrub[®], EZ-Off[®] oven cleaner), or steel wool/scoring pads, which will scratch and damage the stainless steel surface. For heavier oil use liquid degrease such as “Formula 409[®]” or “Fantastic[®]” brand cleaner.
- If the hood looks splotchy (stainless steel hood), use a stainless steel cleaner to clean the surface of the hood. Avoid getting cleaning solution onto or into the control panel. Follow directions of the stainless steel cleaner. **CAUTION: Do not leave on too long as this may cause damage to the hood finish.** Use a soft towel to wipe off the cleaning solution, gently rub off any stubborn spots. Use a dry soft towel to dry the hood.
- After cleaning, you may use non abrasive stainless steel polish such as 3M[®] or ZEP[®], to polish and buff out the stainless luster and grain. Always scrub lightly, with clean cotton cloth, and with the grain.
- DO NOT allow deposits to accumulate or remain on the hood.
- DO NOT use ordinary steel wool or steel brushes. Small bits of steel may adhere to the surface and cause rusting.
- DO NOT allow salt solutions, disinfectants, bleaches, or cleaning compounds to remain in contact with stainless steel for extended periods. Many of these compounds contain chemicals, which may be harmful. Rinse with water after exposure and wipe dry with a clean cloth.

Cleaning Aluminum Grease Filter / Stainless Steel Filterless Grill:

• IMPORTANT: Drain oil from oil containers before oil and residue overflow!

- The metal filters fitted by the factory are intended to filter out residue and grease from cooking. It need not be replaced on a regular basis but are required to be kept clean.
- Filters should be cleaned after every 30 hours of use.
- Remove and clean by hand. Spray “Formula 409” or equivalent degreasing detergent and leave to soak if heavily soiled.
- Dry filters and re-install before using hood.

• **Filters are recommended to be replaced every six months. If you need to repurchase, please go directly to the brand store. If you are not sure of the model number, please feel free to ask customer service.**

• **NOTE: If the received baffle is bent or broken, you can always contact customer service for replacement.**

BULB REPLACEMENT



WARNING

Hazard of Burns

Light bulb can become extremely hot when turned on.
DO NOT touch bulb until switched off and cooled.
Touching hot bulbs could cause serious burns.



WARNING

Hazard of electrical shock!

DO NOT perform service on an electrically live system.
Disconnect the main electrical supply before servicing this device.
Touching electrical connectors or other exposed electrical circuitry inside this range hood when they are energized could result in death, serious bodily injury, or property damage.

Replacing LED 3W 12V Light Fixture:

1. Ensure the range hood's plug is unplugged or the circuit breaker is switched off, and the light feels cool to the touch.
2. Remove the two mesh panels, unscrew the screws on both sides with a screwdriver, disconnect the light's wire, and take out the light board.
3. Forcefully pry open the clips on both sides.
4. Remove the damaged light fixture.
5. Repeat the above steps to install the new LED light.
6. Turn on the circuit breaker and range hood to test if it's working properly.

WARRANTY AND SERVICE

Warranty Period

1. Customers are entitled to replacement or free repair service in case of quality defect(s) found in the product within 15 days upon receipt of the product.
2. Customers are entitled to free repair service from us for any product proven defective in material or workmanship that results in product failure during normal consumer usage and conditions within the valid warranty period, which is 12 months counting from the date of selling. However warranty period varies by product component and country of purchase. Please contact our after-sales service team via ***support@itylza.com*** for detailed warranty information.

Warranty Exclusions

1. Products subjected to unauthorized repair, misuse, collision, neglect, mishandling, soaking, accident, and unauthorized alteration.
2. Products subjected to improper use or whose labels or security tags have been torn off or altered.
3. Products whose warranty has expired.
4. Products damaged due to force majeure, such as fire, flood, lightning, etc.

Warranty Claim Procedure

1. If failure or any problem occurs to your product after purchase, please contact us, or you can always contact our customer service through email at ***support@itylza.com***.
2. Our customer service will guide you through the whole service procedure regarding any product issue or problem you have encountered. We reserve the right to reexamine damaged or returned products.

Contact Card

E-mail: ***support@itylza.com***

phone number: **+1(213)352-5535**



Dispose of this product properly:

To prevent possible harm to the environment or human health from uncontrolled waste disposal, please recycle this product responsibly to promote sustainable reuse of material resources.