

ASSEMBLY INSTRUCTION

- A** Full Headboard Frame **B** Full Footboard Frame **C** Full Headboard Panel **D** Full Footboard Panel

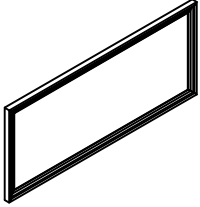

1PC

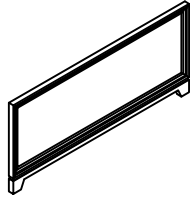

1PC

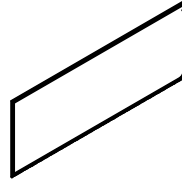

1PC

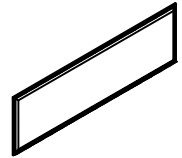

1PC

- E** Headboard Legs (R&L) **F** Legs Support Rails **G** Bolt 5/16" x 45MM **H** Allen Key M4

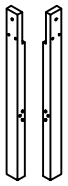

2PCS

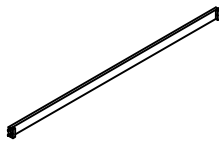

1PC

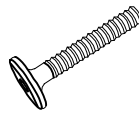

8PCS

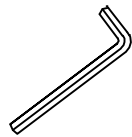

1PC

- I** Spring Washer 5/16" x 12MM **J** Flat Washer 5/16" x 19MM **K** Screw #8 x 25MM



8PCS



8PCS



42PCS

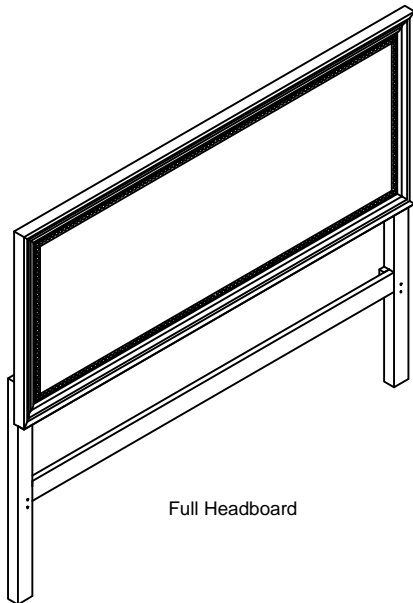

Full Headboard

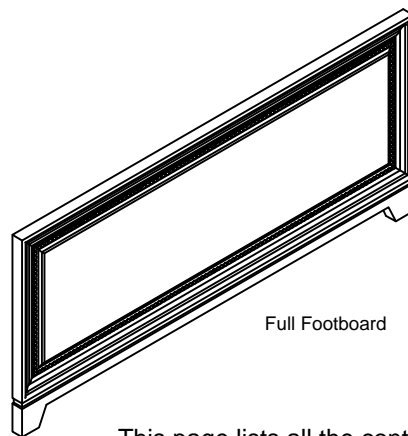

Full Footboard

This page lists all the contents included in the box. Please take the time to identify the hardware as well as the individual components to this product. As you unpack and prepare for assembly, place the contents on the carpeted or padded area to protect them from damage.

- 1** Assembly the Footboard Panel (D) in the Footboard Frame (B) use the Screw (K).
Assembly the Headboard Panel (C) in the Headboard Frame (A) use the Screw (K).

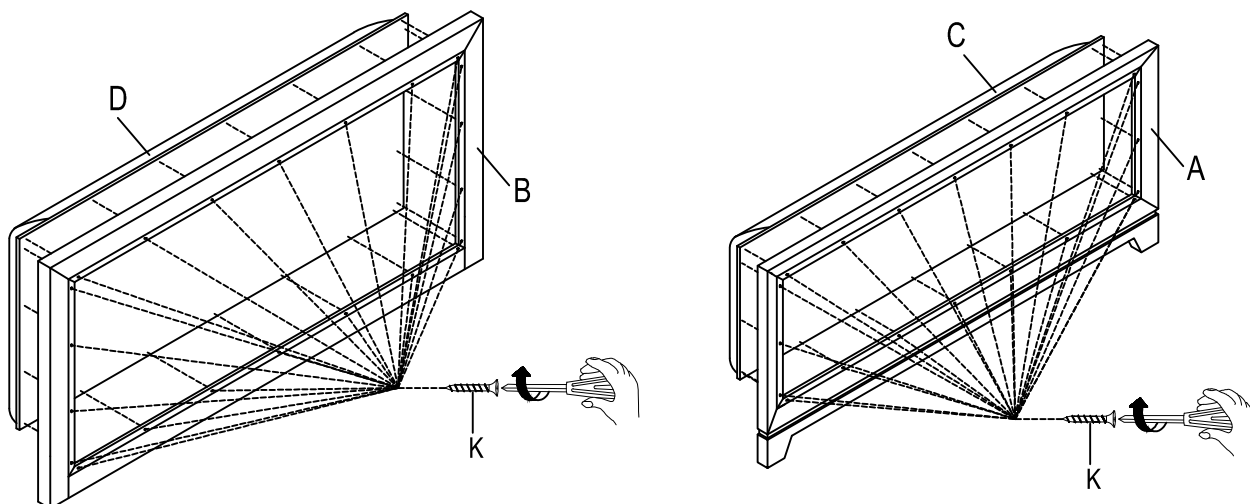



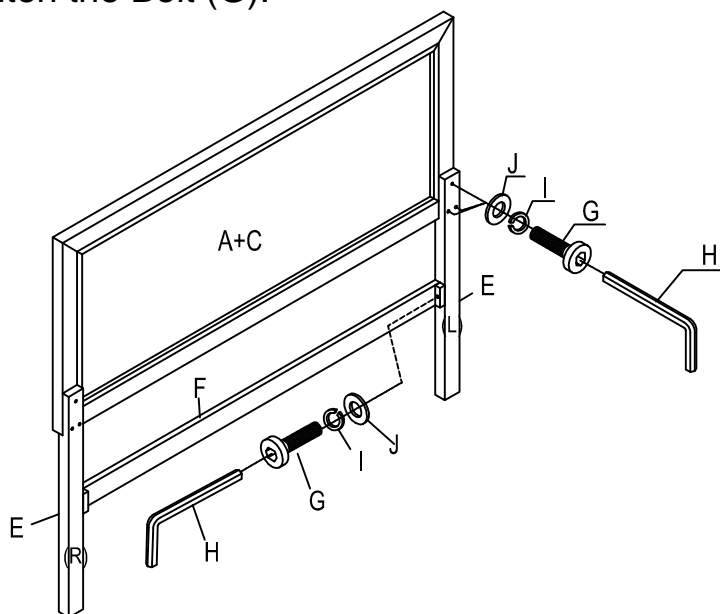



- 2** Assembly the Support Rails(F) between the Two Headboard Legs (E) use the Bolt (G),Spring Washer (I) and Flat Washer (J).So assembly the Headboard(A+C) on the Legs Set (E+F) use the Bolt (G),Spring Washer (I) and Flat Washer (J).The Allen Key (H) tighten the Bolt (G).

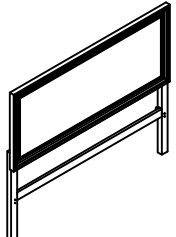
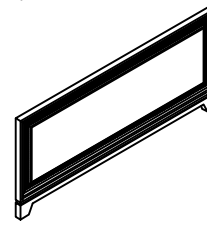
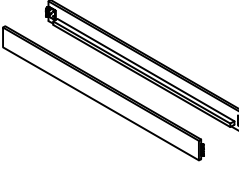
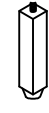
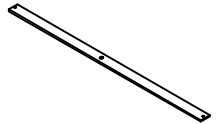

Cleaning & Care

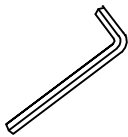
Treat surface with care. Surface is resistant to scratches but is not scratch resistant. Clean surfaces with a dry or damp soft cloth. Do not use abrasive cleaners. Hardware may loosen over time. Periodically check that all connections are tight.

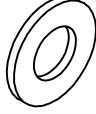
ASSEMBLY INSTRUCTION

A Full Headboard (In the other carton)	B Full Footboard (In the other carton)	C Side Rails	D Support Legs	E Slats
				
1PC	1PC	2PCS	4PCS	4PCS
F Bolt 5/16" x 19MM	G Allen Key M4	H Spring Washer 5/16" x 12MM	I Flat Washer 5/16" x 19MM	J Screw #8 x 30MM
				
8PCS	1PC	8PCS	8PCS	8PCS

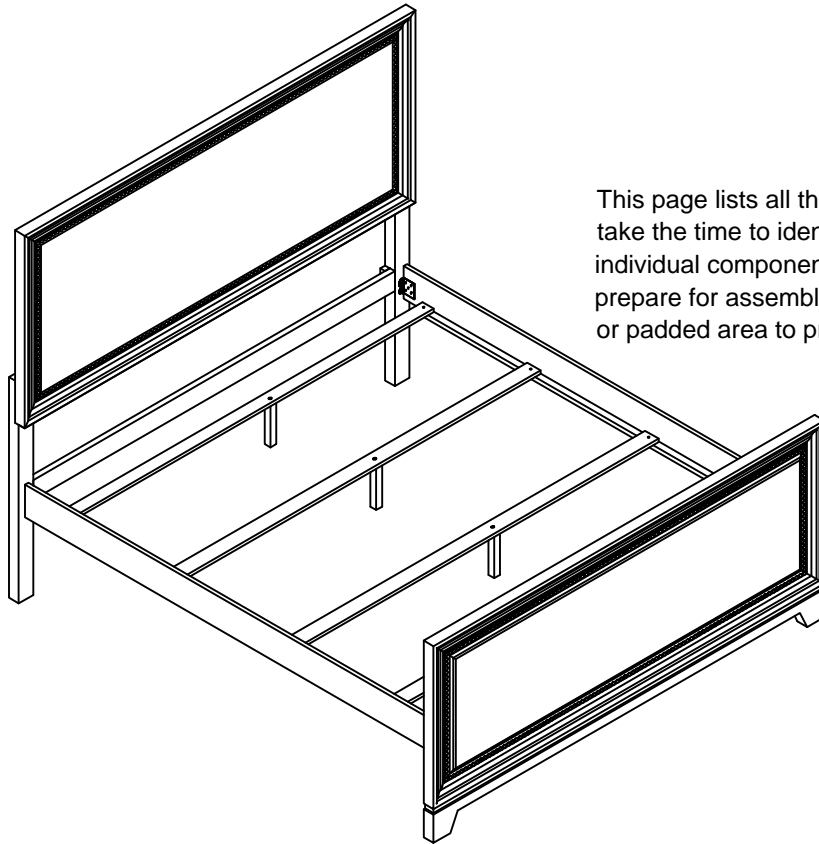

This page lists all the contents included in the box. Please take the time to identify the hardware as well as the individual components to this product. As you unpack and prepare for assembly, place the contents on the carpeted or padded area to protect them from damage.

-
- 1** Insert Bolt (F), Spring Washer (H) and Flat Washer (I) to the Side Rails (C) connection with the Headboard (A) and Footboard (B). The Allen Key (G) tighten the Bolt (F).

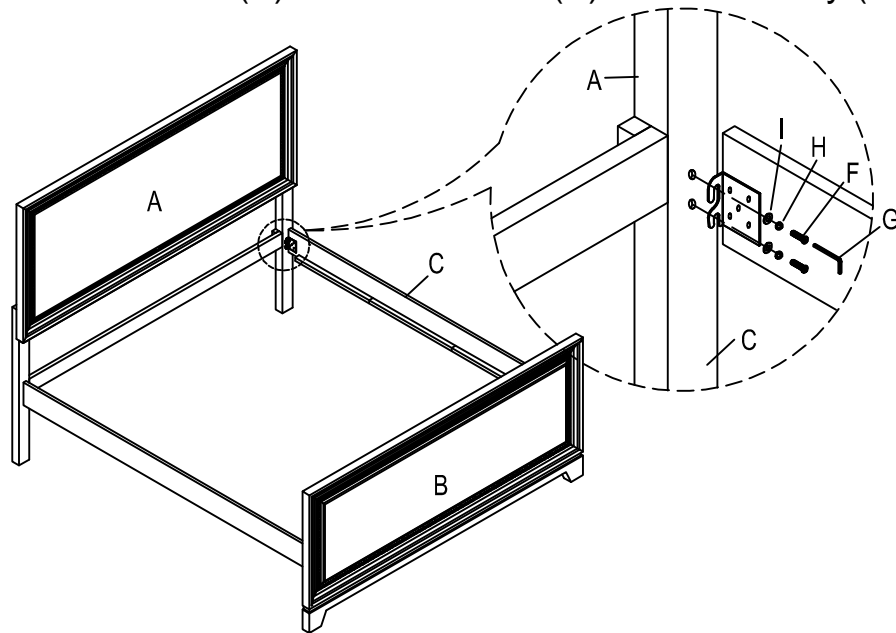

-
- 2** Install the Support Legs (D) on the Slats (E) and Screwed the Slats (E) at the Side Rails (C) use the Screw (J).

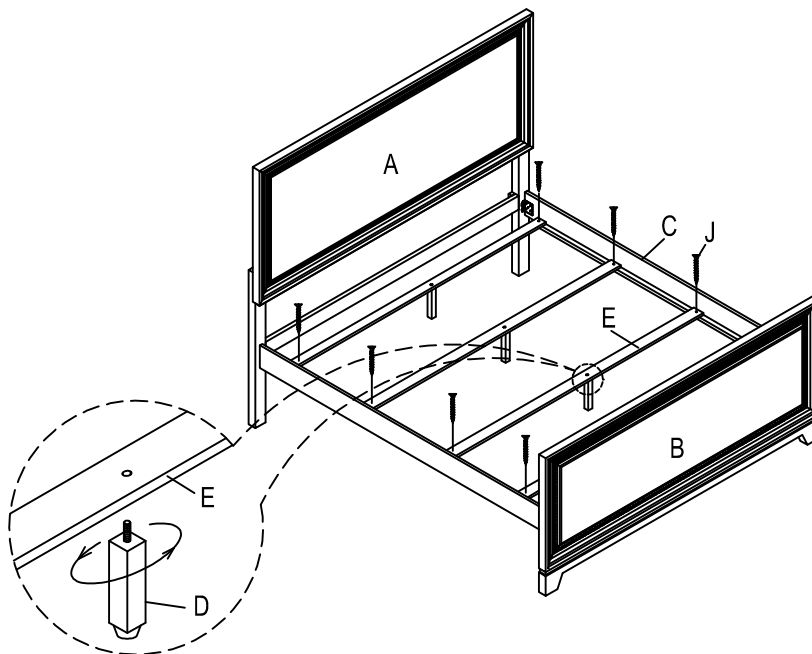

Cleaning & Care

Treat surface with care. Surface is resistant to scratches but is not scratch resistant. Clean surfaces with a dry or damp soft cloth. Do not use abrasive cleaners. Hardware may loosen over time. Periodically check that all connections are tight.