

Palma C80.000

Features



- Vanity Base Unit
- Available in 3 Finishes: Natural Oak, Grey Pine, and Wenge
- Wall-hung design offers a clean, streamlined look
- Two soft close drawers with organizer in upper drawer
- Hettich sliding system
- Fully assembled
- Structure and front made of engineered wood in wood finishes and high gloss lacquered
- Handle integrated in front of furniture
- Does not include vanity top or sink
- Made in Spain



SKU# | Options:

- Palma C80.000 NO | Natural Oak
- Palma C80.000 WM | White Matte
- Palma C80.000 MKM | Moka Matte

Finishes:

-  Natural Oak
-  Matte White
-  Moka Matte

Codes & Standards:

- CARB2 Compliant and Certified; TSCA Compliant and Certified

* WS Bath Collections reserves the right to revise dimensions or information on this sheet without notice

Collection |
Palma

Model |
Palma C80.000

Dimensions Metric
1 inch = 2.54 cm
1 inch = 25.4 mm

 **WS** BATH
COLLECTIONS

1051 Lea Drive - Collegeville, PA 19426
Tel. 215 513 9400 - Fax 610 831 0215
www.ws bathcollections.com - info@ws bathcollections.com

Palma C80

Sink

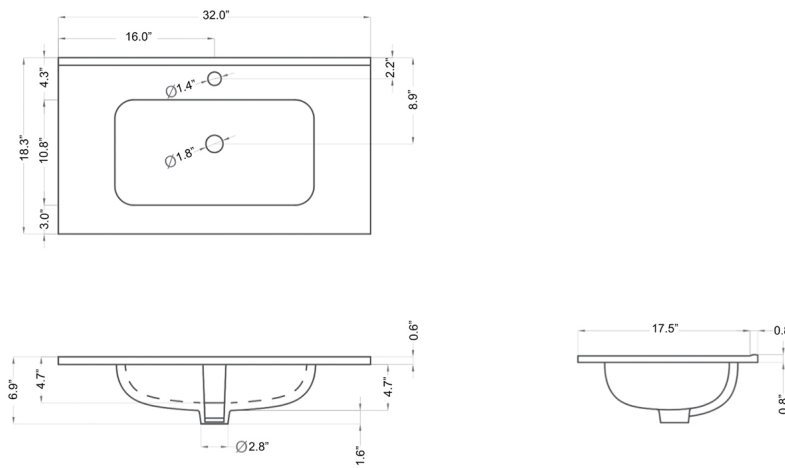

Base Unit

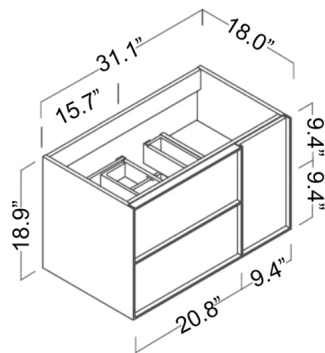

Drain centered on all measures.

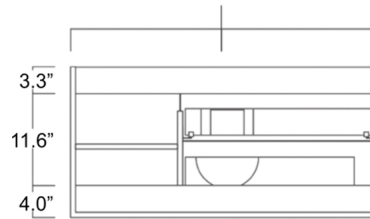

Technical information



Organizer unit.



Hettich sliding system.



Adjustable front.



Soft close.



Soft close.



Glossy lacquered finish.

- Height and depth adjustable suspension.
- 2 adjustable drawers and door with silents-low closing and integrated handles.
- 16 mm MDF front / 16 mm MDF side panels.

Collection |
Palma

Model |
Palma C80

Dimensions Metric

1 inch = 2.54 cm

1 inch = 25.4 mm

WS®
BATH
COLLECTIONS

1051 Lea Drive - Collegeville, PA 19426
Tel. 215 513 9400 - Fax 610 831 0215

www.ws bathcollections.com - info@ws bathcollections.com