

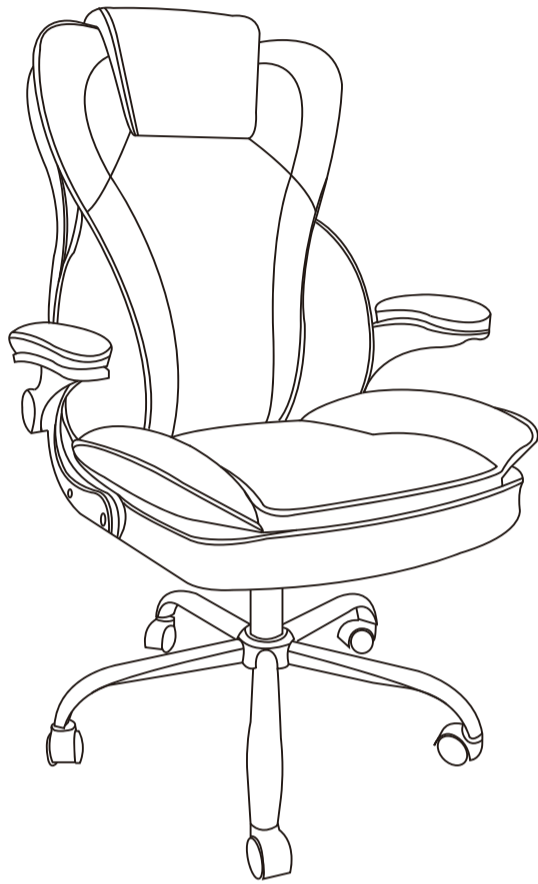









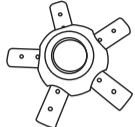
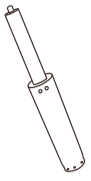
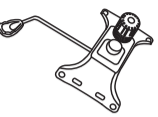

# OFFICE CHAIR

## ASSEMBLY INSTRUCTIONS



### Assembly Instruction

#### Parts List

<b>A</b> 	<b>B</b> 	<b>C</b> 	<b>D</b> 	<b>E</b> 
5PCS	5PCS	1PC	1PC	1PC
<b>F</b> 	<b>G</b> 	<b>I<sub>1</sub></b> 	<b>I<sub>2</sub></b> 	<b>J</b> 
1PC	1PC	1PC	1PC	M6*30mm 8PCS
<b>K</b> 	<b>L</b> 	<b>M</b> 	<b>N</b> 	
M6*16mm 10PCS	M6*20mm 4PCS	1PC	8PCS	

Please note: Please check carefully if there are any missing parts before installation. If there are any missing parts, please place all the parts and take pictures then tell us the missing part number. We will reply you as soon as possible.

1

### Assembly Instruction

#### Chair Assembly

##### Step 1

- A\*5
- C\*1
- K\*10
- M\*1

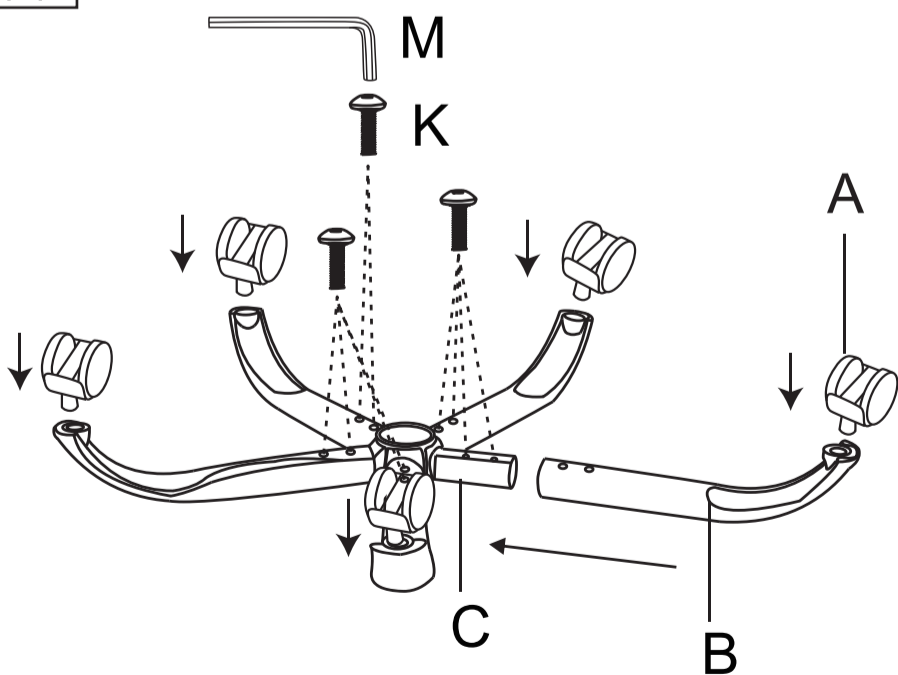

2

### Assembly Instruction

#### Chair Assembly

##### Step 2

- D\*1

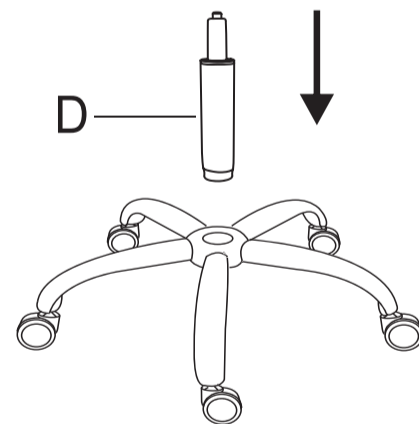

##### Step 3

- E\*1
- G\*1
- L\*4
- M\*1

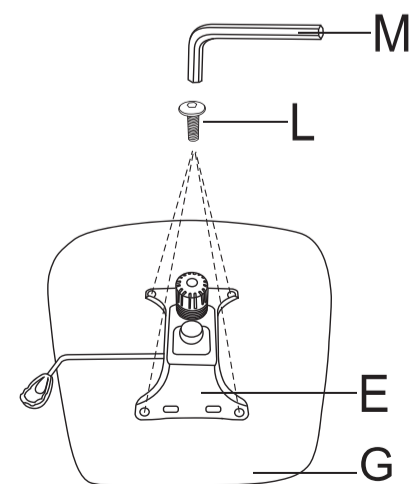

3

# Assembly Instruction

## Chair Assembly

### Step 4

- I<sub>1</sub>\*1
- I<sub>2</sub>\*1
- J\*4
- M\*1

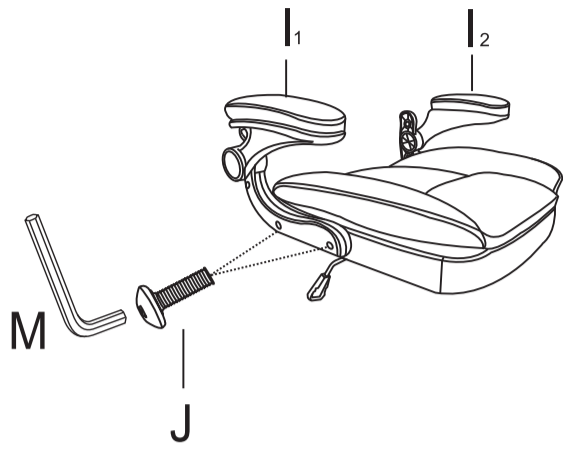

For this installation step, please tighten the screws to 60%

### Step 5

- F\*1
- J\*4
- M\*1
- N\*8

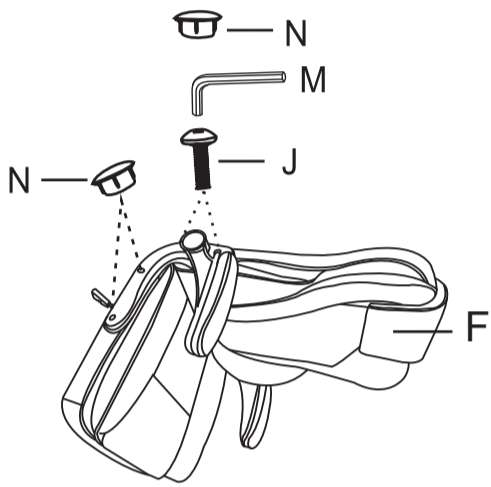

For this installation step, please tighten the screws to 100%

4

# Assembly Instruction

## Chair Assembly

### Step 6

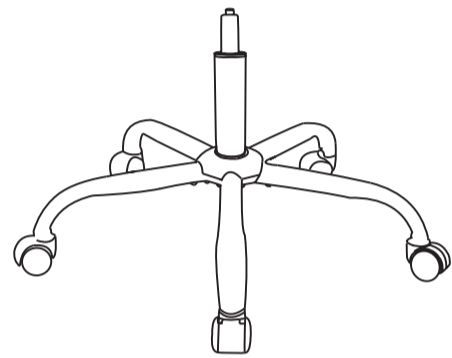
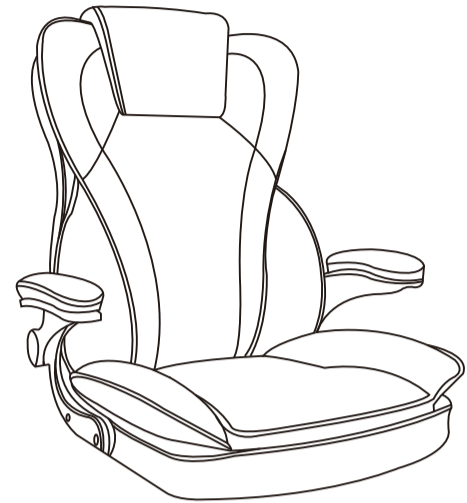

5

# Assembly Instruction

## Chair Assembly

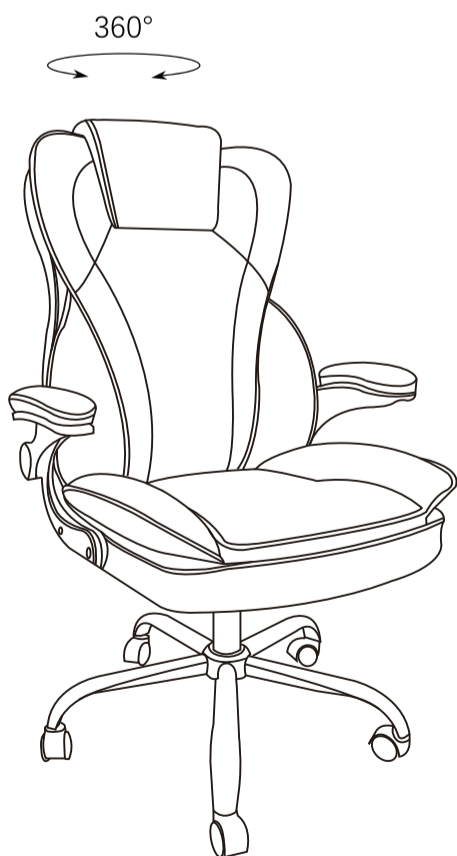

6