





ASSEMBLY INSTRUCTION

NUMBER	COMPONENT	QUANTITY
A	 <p>TABLE TOP</p>	1
B	 <p>LEG</p>	2
1	 <p>Bolt (M6 x 40mm)</p>	7
2	 <p>Sleeve Nut (6 x 13mm)</p>	7
3	 <p>Allen Wrench</p>	2

ASSEMBLY INSTRUCTION

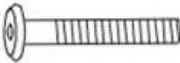
①

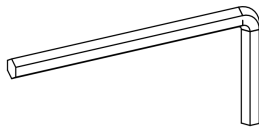
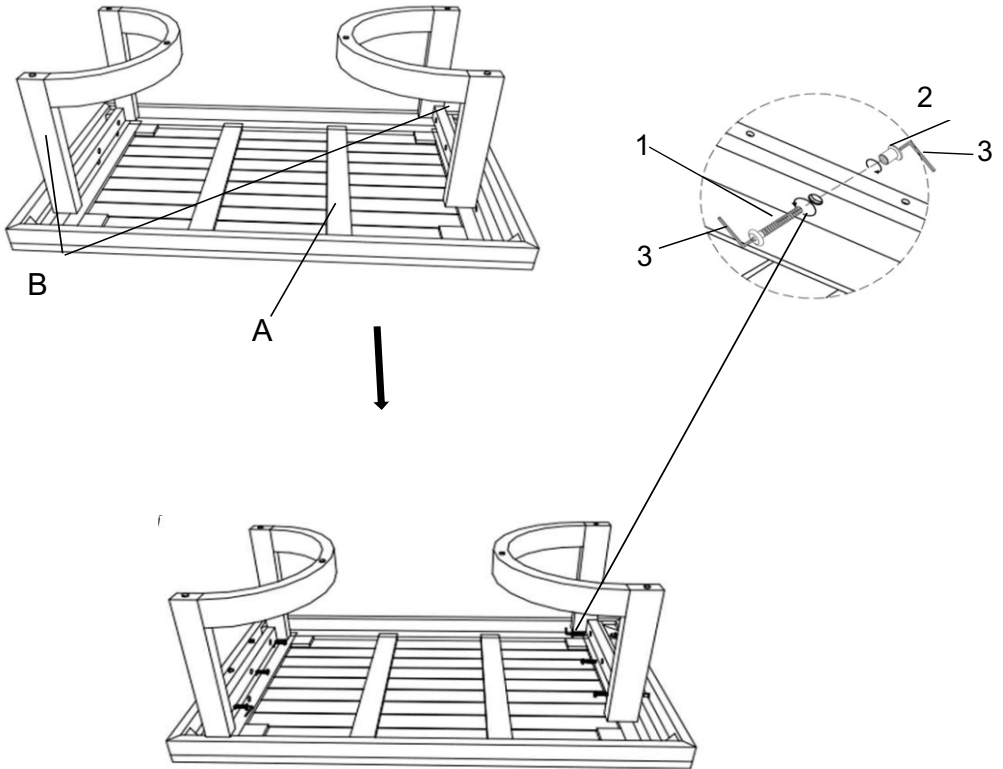

Place the Table Top(A) facing down on the non-marring surface.

Attach the Leg(B) into the Table Top(A) using Bolt(①), Sleeve Nut(②) and Allen Wrench(③) to assemble.

Repeat the same process for the remaining Leg(B).

Note : only eighteen 80%.

ASSEMBLY INSTRUCTION

②

