











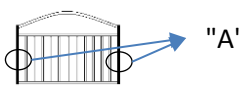

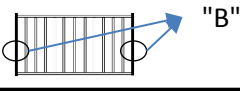

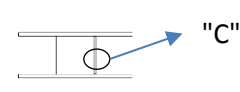
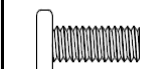
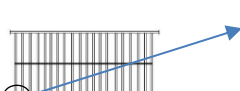
ASSEMBLY INSTRUCTIONS

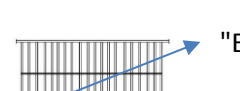
PAGE 1 OF 5

NOTE: THIS ITEM NOT RECOMMENDED FOR COMMERCIAL USE

KEEP THIS DOCUMENT FOR REFERENCE IN CASE PARTS ARE NEEDED

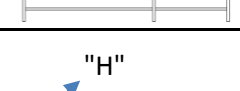
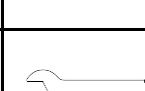
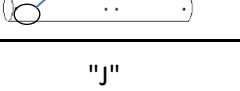
DO NOT TIGHTEN SCREWS UNTIL COMPLETELY ASSEMBLED!!

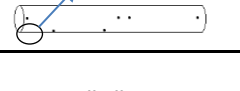
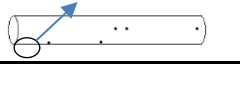
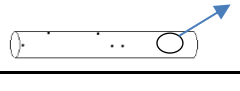
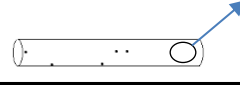
BED PARTS			HARDWARE PARTS		
No	DESCRIPTION	QTY	No	DESCRIPTION	QTY
A	 "A" Upper Head Panel	2 PCS	1	 1/4" × 85mm	16 PCS
B	 "B" Lower Head Panel	2 PCS	2	 1/4" × 15mm	31 PCS
C	 "C" Ladder	1 PC	3	 1/4" × 65mm	6 PCS
D	 "D" Upper Bed Frame	1 PC	4	 1/4" Curved Washer	24 PCS
E	 "E" Lower Bed Frame	1 PC	5	 1/4" Flate Washer	37 PCS
F	 "F" Back Guardrail	1 PC	6	 1/4" locked Nut	8 PCS
G	 "G" Front Guardrail	1 PC	7	 4# Allen Wrenches	1 PC
H	 "H" Upper Main Post	2 PCS	8	 4# Allen Wrenches	1 PC
J	 "J" Upper Main Post	1 PC			
K	 "K" Upper Main Post	1 PC			
L	 "L" Lower Main Post	2 PCS			
M	 "M" Lower Main Post	2 PCS			
N	 "N" Conector	4 PCS			

ASSEMBLY INSTRUCTIONS

PAGE 2 OF 5

NOTE: THIS ITEM NOT RECOMMENDED FOR COMMERCIAL USE

KEEP THIS DOCUMENT FOR REFERENCE IN CASE PARTS ARE NEEDED

DO NOT TIGHTEN SCREWS UNTIL COMPLETELY ASSEMBLED!!

Size of Mattress

This bed is designed to use a mattress 74" x 37-1/2" – 38-1/2" on the upper bunk and the lower bunk. The thickness of the mattress must not exceed 6" on the upper bunk. There must be at least 5" from mattress sleeping surface to top edge of guard rail on the upper bunk.

Replacement Parts

Replacement parts, including additional guardrails, may be obtained from any of our retail dealers.

Additional Note

Maximum total weight not to exceed 150 lbs. on the upper bunk, and maximum 200 lbs. on the lower bunk

SAFETY WARNINGS (ASTM F1427-13)

1. Follow the information on the warnings appearing on the upper bunk end structure and on the carton. Do not remove warning label from bed.
2. Always use the recommended size mattresses or mattress supports, or both, to help prevent the likelihood of entrapment or falls.
3. Surface of mattress must be at least 5 in. (127 mm) below the upper edge of guardrails.
4. Do not allow children under 6 years of age to use the upper bunk.
5. Periodically check and ensure that the guardrail, ladder, and other components are in their proper position, free from damage, and that all connectors are tight.
6. Do not allow horseplay on or under the bed and prohibit jumping on the bed.
7. Always use the ladder for entering and leaving the upper bunk.
8. Do not use substitute parts. Contact the manufacturer or dealer for replacement parts.
9. Use of a night light may provide added safety precaution for a child using the upper bunk.
10. Always use guardrails on both long sides of the upper bunk. If the bunk bed will be placed next to the wall, the guardrail that runs the full length of the bed should be placed against the wall to prevent entrapment between the bed and wall.
11. The use of water or sleep flotation mattresses is prohibited.
12. **STRANGULATION HAZARD**–Never attach or hang items to any part of the bunk bed that are not designed for use with the bed; for example, but not limited to, hooks, belts and jump ropes.
13. Keep these instructions for future reference.
14. Prohibit more than one person on upper bunk.
15. Adult assembly required due to the presence of small parts ,sharp points,sharp edgesas recesived.

ASSEMBLY INSTRUCTIONS

PAGE 3 OF 5

NOTE: THIS ITEM NOT RECOMMENDED FOR COMMERCIAL USE

KEEP THIS DOCUMENT FOR REFERENCE IN CASE PARTS ARE NEEDED

DO NOT TIGHTEN SCREWS UNTIL COMPLETELY ASSEMBLED!!

SAFETY WARNINGS (16 CFR 1513)

- (1) Do not allow children under 6 years of age to use the upper bunk.**
- (2) Use guardrails on both sides of the upper bunk.**
- (3) Prohibit horseplay on or under beds.**
- (4) Prohibit more than one person on upper bunk.**
- (5) Use ladder for entering or leaving upper bunk.**
- (6) If the bunk bed will be placed next to a wall, the guardrail that runs the full length of the bed should be placed against the wall to prevent entrapment between the bed and the wall. (This applies only to bunk beds without two full-length guardrails.)**

STEP 1, 2

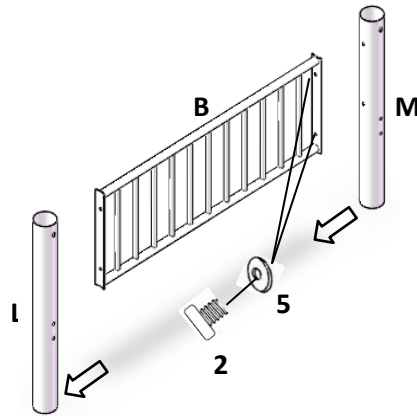

STEP 3

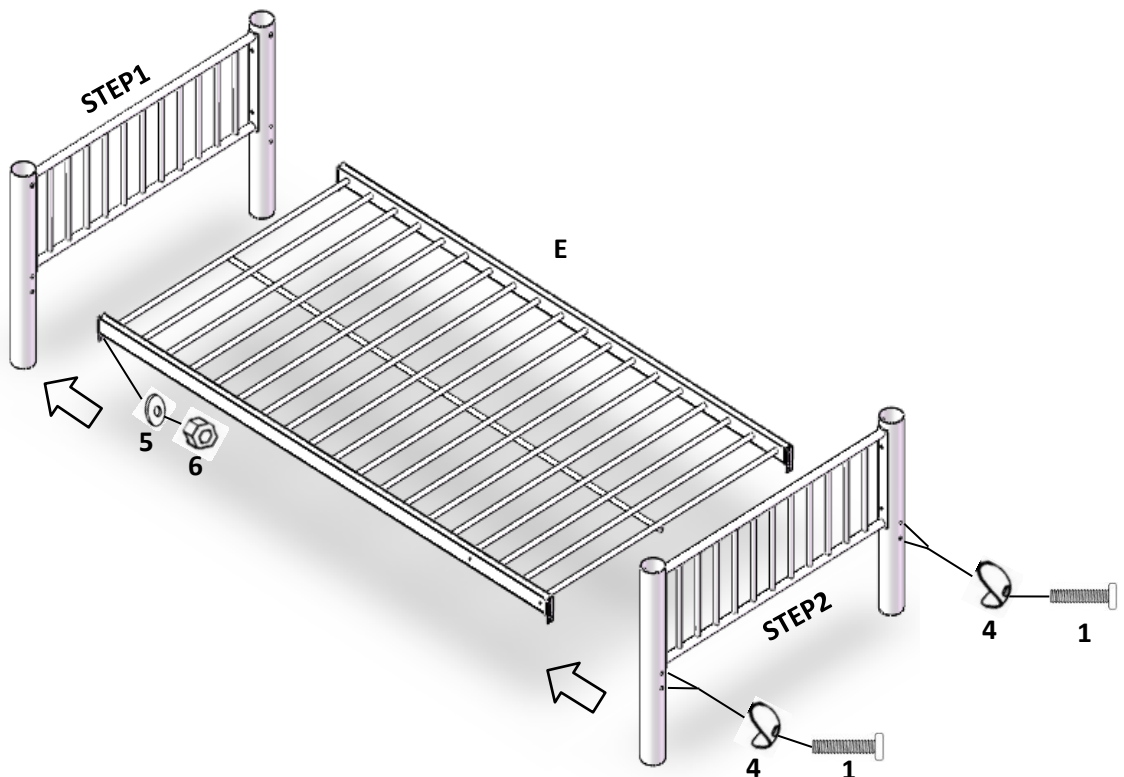

ASSEMBLY INSTRUCTIONS

PAGE 4 OF 5

NOTE: THIS ITEM NOT RECOMMENDED FOR COMMERCIAL USE
KEEP THIS DOCUMENT FOR REFERENCE IN CASE PARTS ARE NEEDED
DO NOT TIGHTEN SCREWS UNTIL COMPLETELY ASSEMBLED!!

STEP 4

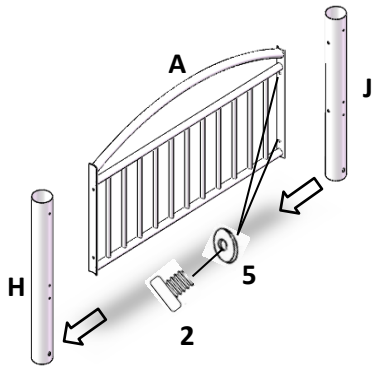

STEP 5

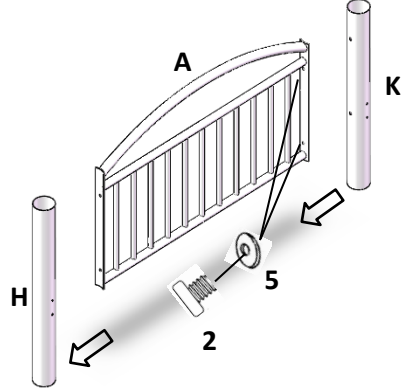

STEP 6

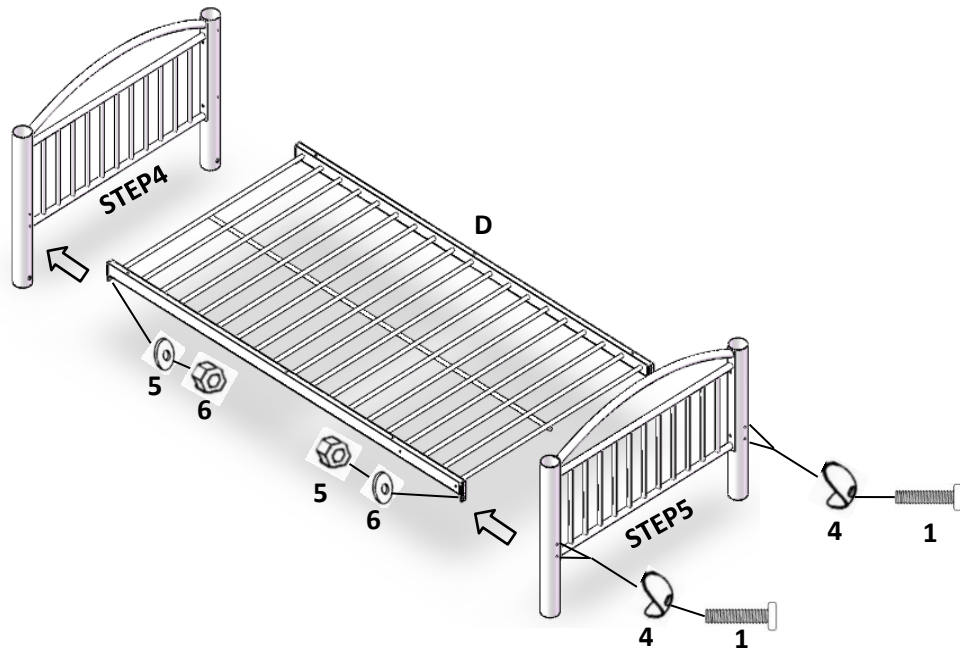

STEP 7

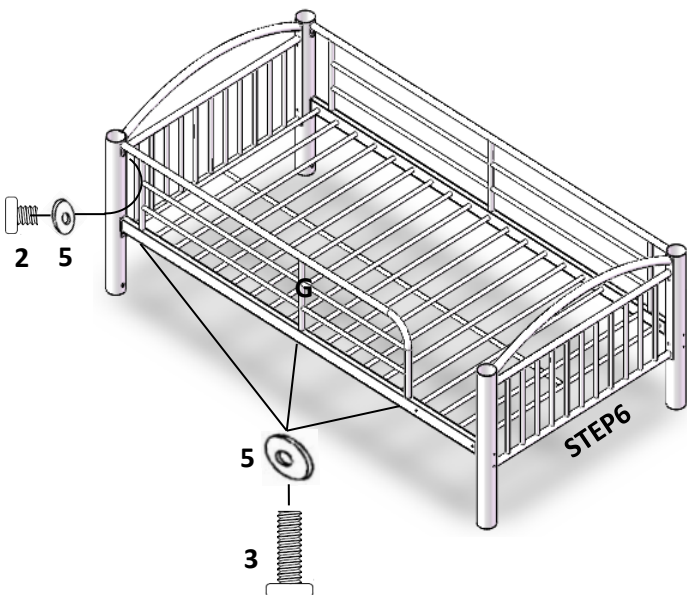

STEP 8

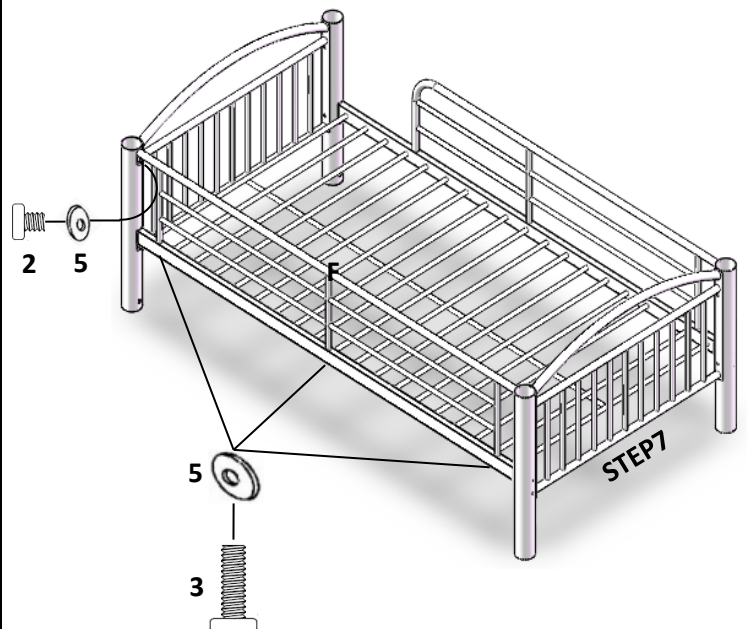

ASSEMBLY INSTRUCTIONS

PAGE 5 OF 5

NOTE: THIS ITEM NOT RECOMMENDED FOR COMMERCIAL USE
KEEP THIS DOCUMENT FOR REFERENCE IN CASE PARTS ARE NEEDED
DO NOT TIGHTEN SCREWS UNTIL COMPLETELY ASSEMBLED!!

STEP 9

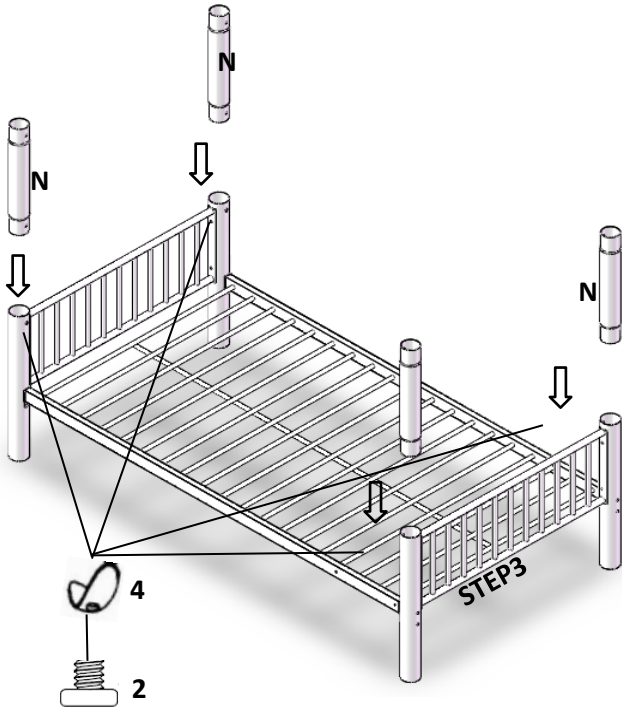

STEP 10

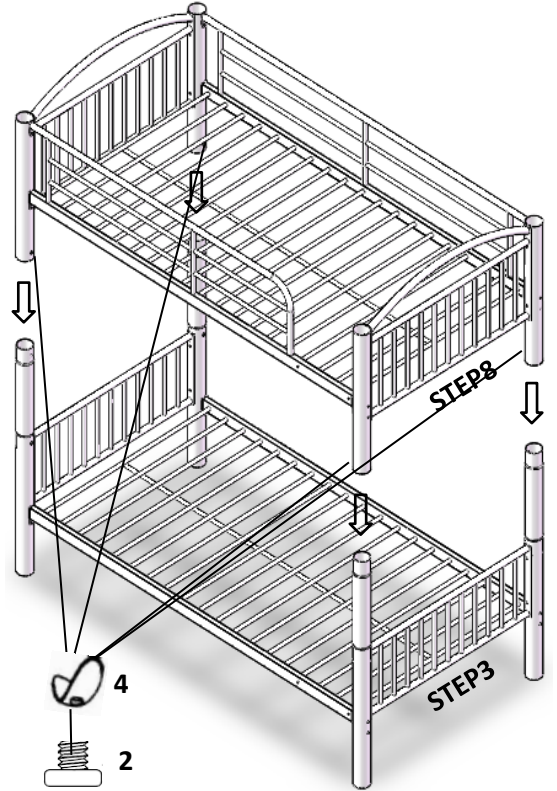

STEP 11

