

# DOUBLE-TIERED DINING CART

CARRITO DE COMEDOR DE DOBLE CAPA

CHARIOT À MANGER À DOUBLES ÉTAGES



## FOR YOUR SAFETY! | ¡PARA SU SEGURIDAD! | POUR VOTRE SÉCURITÉ!

Use outdoors only!  
Read the instructions before  
assembling and using the appliance.







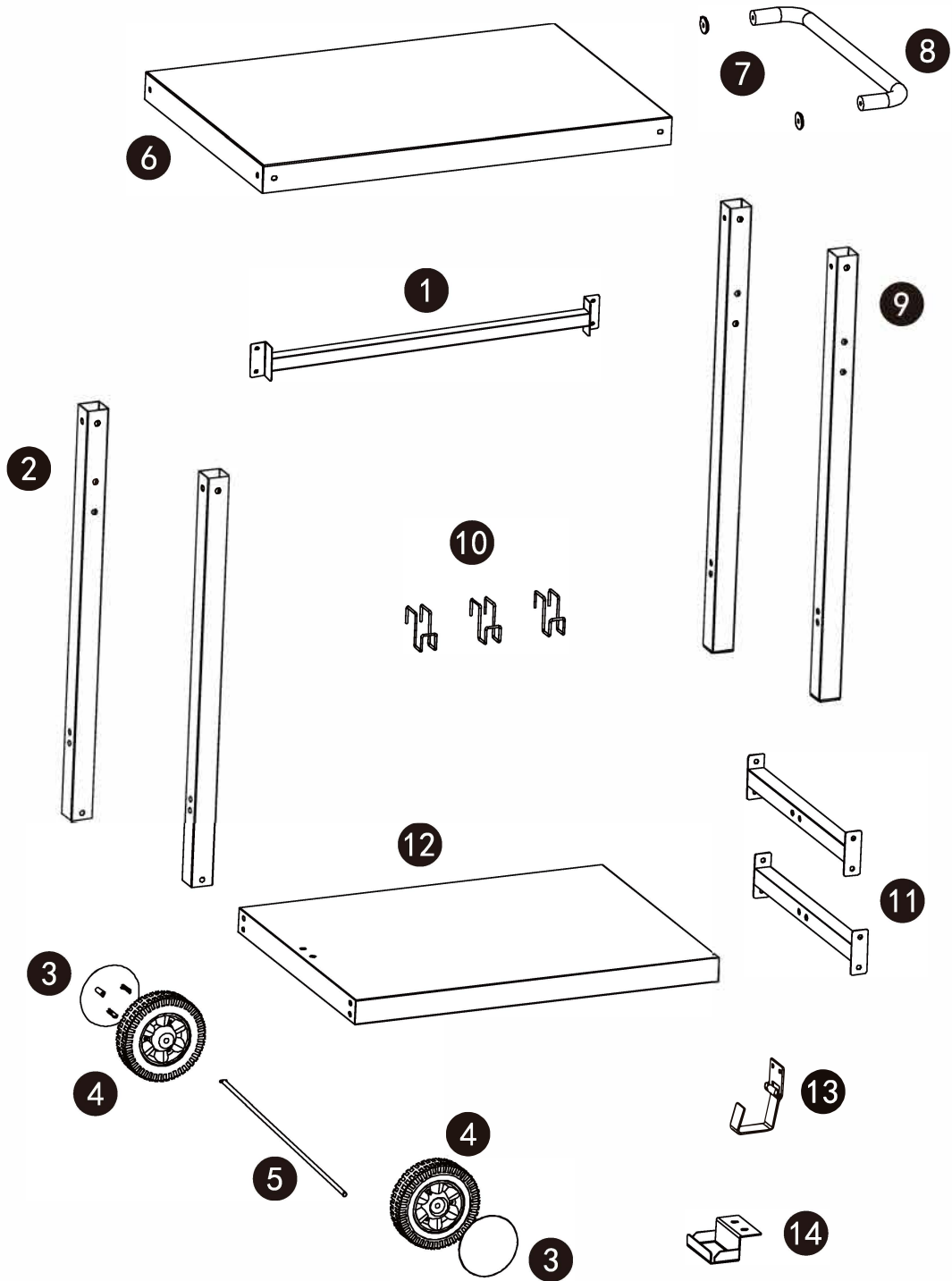



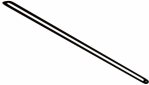

¡Solo usa al aire libre!  
Lea las instrucciones antes  
de montar y utilizar el aparato.

Utilisez uniquement à l'extérieur!  
Lisez les instructions avant  
d'assembler et d'utiliser l'appareil.



Parts Diagram / Diagrama de partes / Schema des pièces

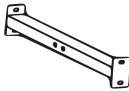
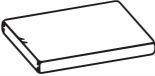





## Parts List / Lista de piezas / Liste des pièces

No. #	QYT / CANT. / QTÉ	Description / Descripción / Description	Image / Imagen / l' image
1	1	Cart front beam Viga frontal del carro Poutre avant du chariot	
2	2	Left leg Pata izquierda Jambe gauche	
3	2	Rim cover Cubierta de la llanta Couverture de la jante	
4	2	Wheel Rueda Roue	
5	1	Wheel axle Eje de rueda Essieu de roue	
6	1	Table top Parte superior de la mesa Plateau de table	
7	2	Handle sleeve Base de encastre del tirador Manche de poignée	
8	1	Handle Manija Poignée	
9	2	Right leg Pata derecha Jambe droite	
10	3	Hook Gancho Crochet	
11	2	Cart side beam Viga lateral del carro Poutre latérale du chariot	
12	1	Bottom shelf Estante inferior Étagère inférieure	
13	1	LP cylinder hook Gancho para bombona de gas Crochet de bouteille de gaz	
14	1	LP cylinder base Base del bombona de gas Base de bouteille de gaz	

### TOOLS REQUIRED / HERRAMIENTAS REQUERIDAS / OUTILS REQUIS

Description / Descripción / Description	Image / Imagen / l' image
Phillips screwdriver Destornillador phillips Tournevis phillips	
Wrench Llave Clé	

## Hardware List / Lista de hardware / Liste du matériel

Key / Clave / Réf.	Description / Descripción / Description	QTY / CANT. / QTÉ	Image / Imagen / l' image
A	M6x55	12	
B	M6x15	16	
C	Split pin Pasador Goupille fendue	1	
D	Washer Arandela Rondelle	3	
E	Nut Tuerca Écrou	2	

Before beginning assembly, make sure all parts are present. If any parts are missing or damaged, do not attempt to assemble the products. Contact customer service for replacement parts via telephone or email.

- Tools needed: Phillips screwdriver and wrench (not included)
- Approximate assembly time: 15 minutes

Antes de comenzar el montaje, asegúrese de que todas las piezas estén presentes. Si falta alguna pieza o está dañada, no intente ensamblar los productos. Póngase en contacto con el servicio de atención al cliente para obtener piezas de repuesto por teléfono o correo electrónico.

- Herramienta necesaria: Destornillador phillips y llave (no incluido)
- Tiempo aproximado de ensamblaje: 15 minutos

Avant de commencer l'assemblage, assurez-vous que toutes les pièces sont présentes. Si des pièces sont manquantes ou endommagées, n'essayez pas d'assembler les produits. Contactez le service de clientèle pour les pièces de rechange par téléphone ou par e-mail.

- Outils nécessaires: Tournevis phillips et clé (non inclus)
- Temps nécessaire pour l'assemblage: 15 minutes

- |          |   |   |    |
|----------|---|---|----|
| <b>1</b> | B |  | ×4 |
|----------|---|---|----|

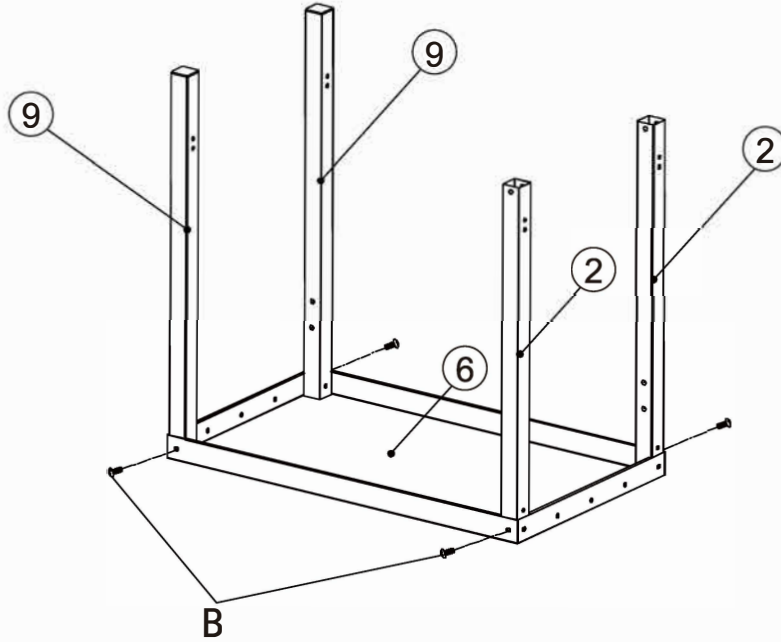

- |          |   |   |    |
|----------|---|---|----|
| <b>2</b> | A |  | ×4 |
|          | E |  | ×2 |

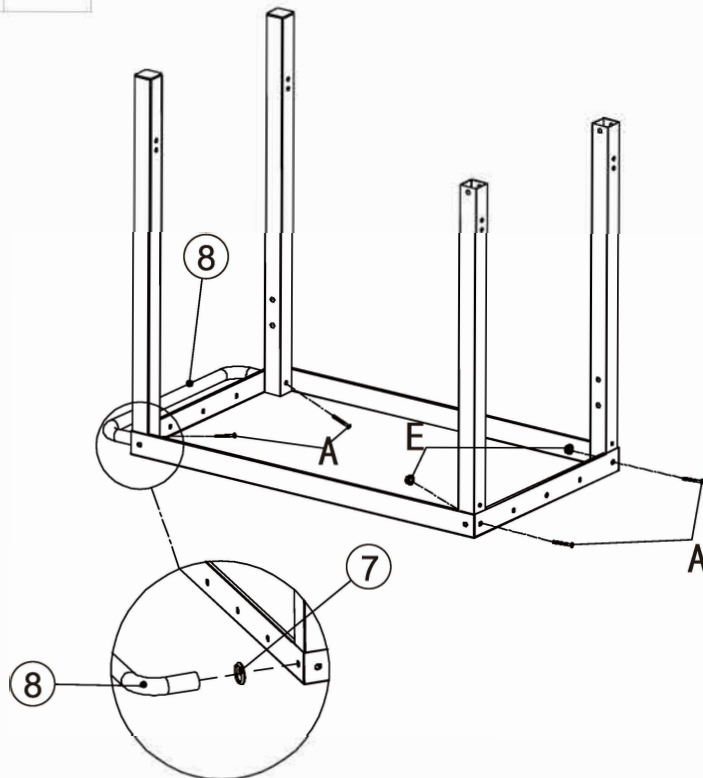

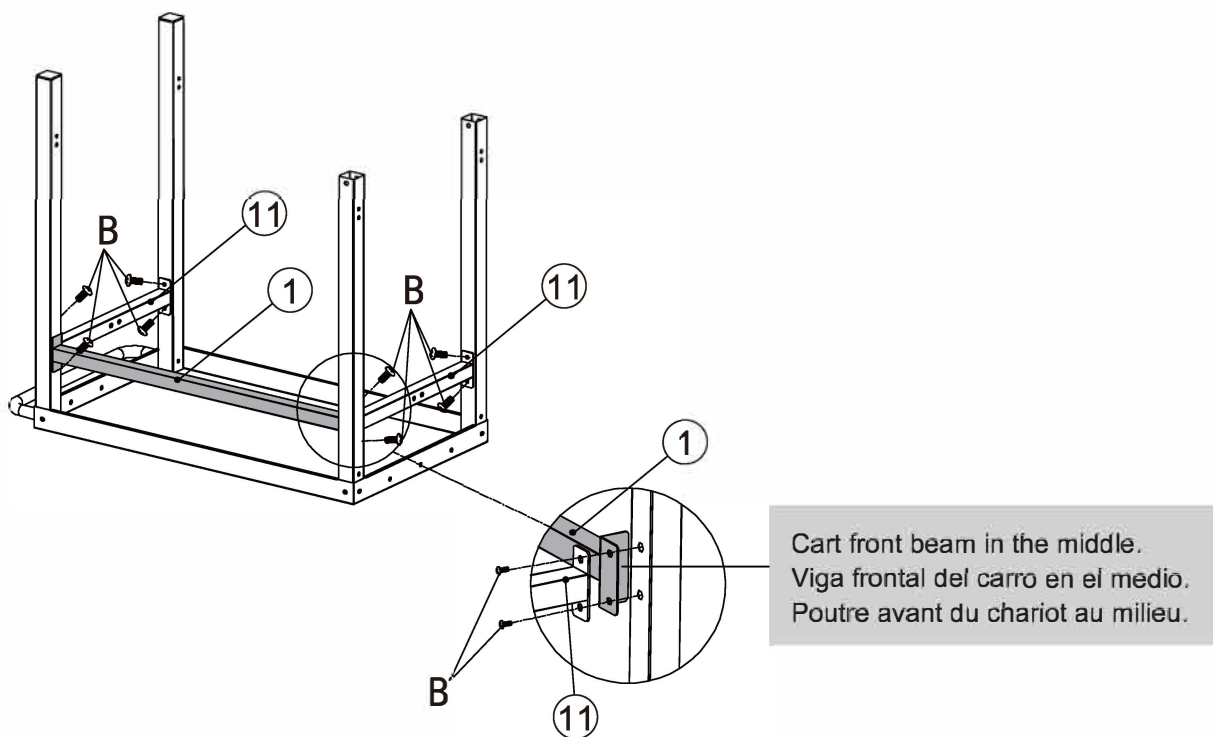

**3** B  ×8

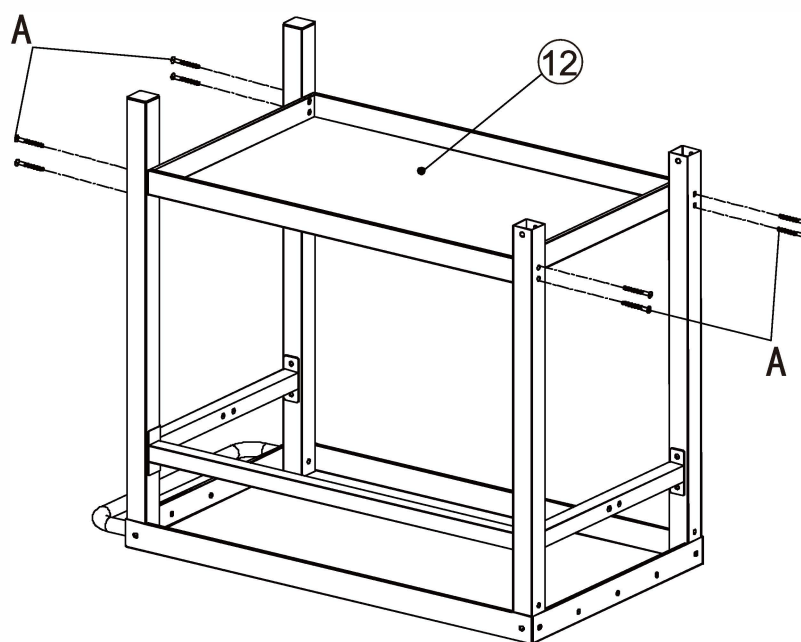

**4** A  ×8



<b>5</b>	<b>D</b>		<b>×3</b>
	<b>C</b>		<b>×1</b>

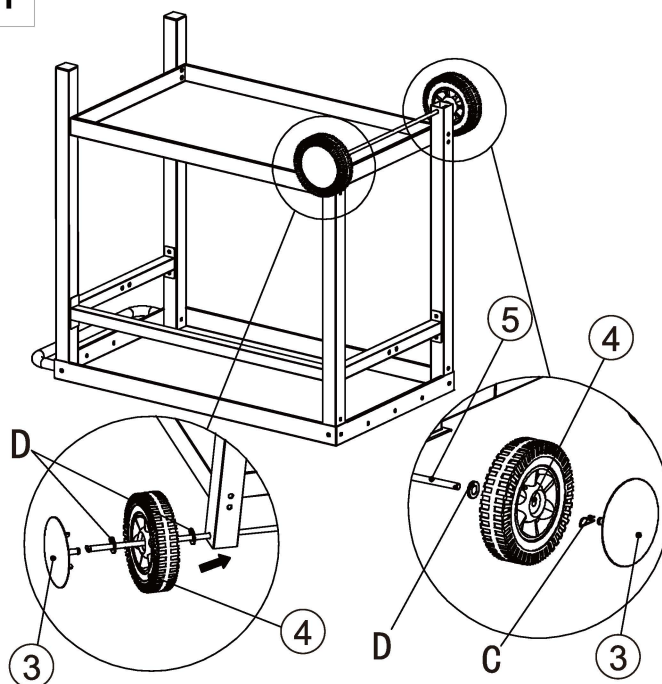

<b>6</b>	<b>B</b>		<b>×4</b>
----------	----------	---	-----------

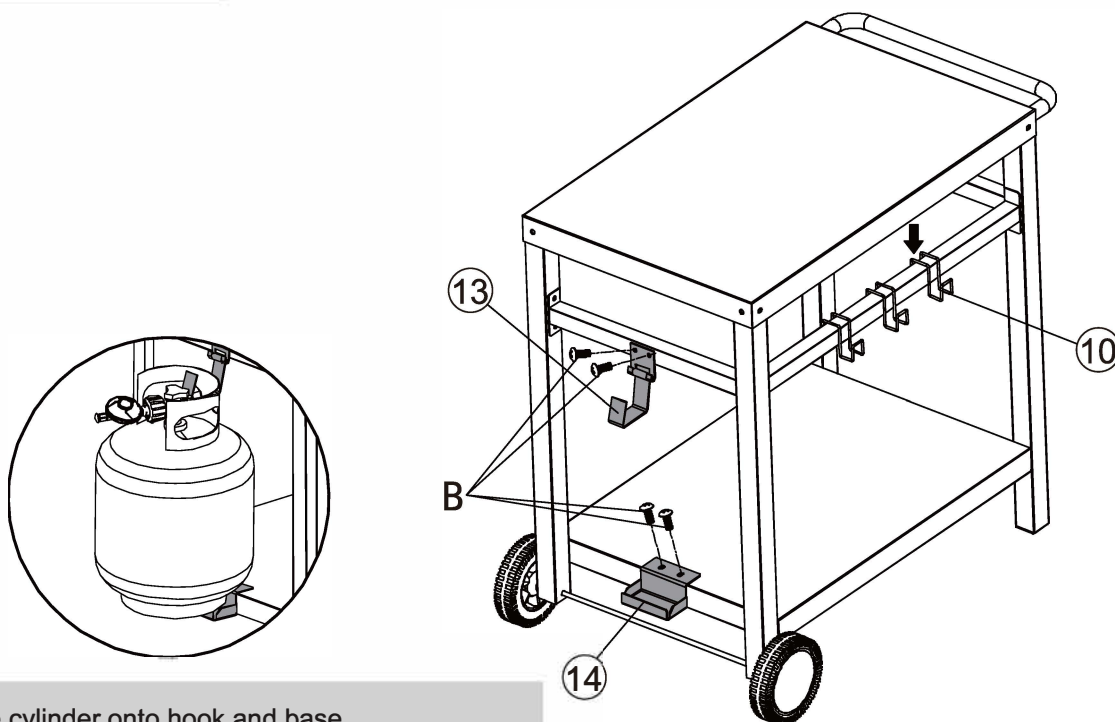

NOTE: Secure cylinder onto hook and base.  
 REMARQUE: Asegure el bombona en el gancho y la base.  
 NOTA: Fixez la bouteille sur le crochet et la base.