

ASSEMBLY INSTRUCTIONS

HARDWARE LIST

CARTON	NO.	SKETCH	DESCRIPTION	QTY
2-2	1		Bolt (1/4" x 1-1/4")	12 PCS
	2		Bolt (1/4" x 1-3/4")	3 PCS
	3		Bolt (1/4" x 3/4")	3 PCS
	4		Spring Washer (1/4")	15 PCS
	5		Washer (1/4")	15 PCS
	6		Allen Wrench (4mm)	1 PC

PARTS LIST

CARTON	NO.	SKETCH	DESCRIPTION	QTY
2-1	A		Table top	1 PC
2-2	B		Pedestal	3 PCS
	C		Top Ring	1 PC
	D		Base Ring	1 PC

Step 1

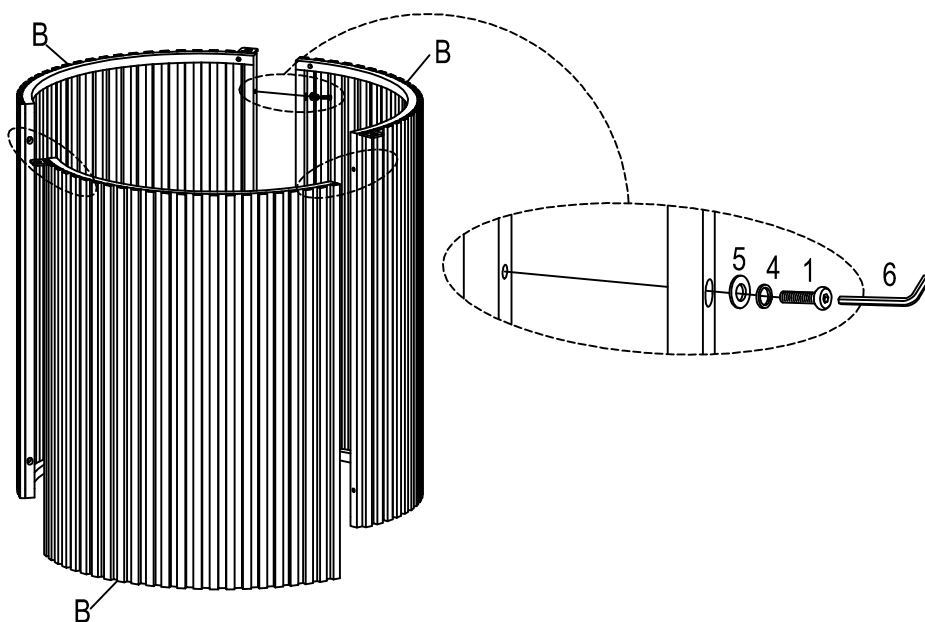

Note: At this stage, do not fully tighten the bolts .

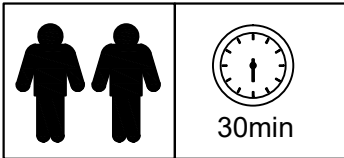

ASSEMBLY INSTRUCTIONS

Step 2

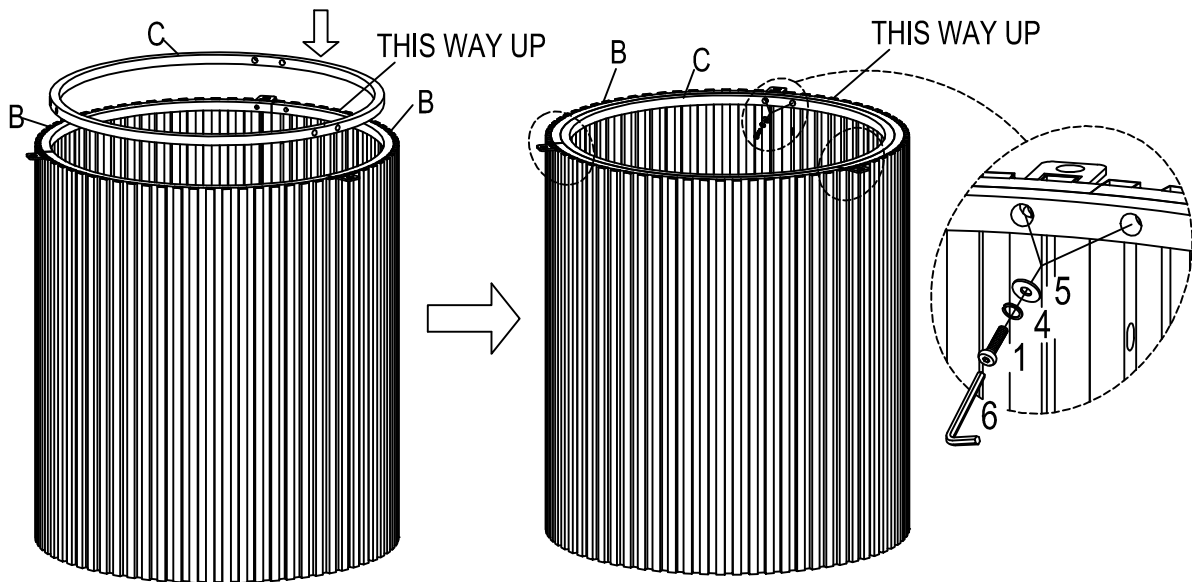

Note: At this stage, do not fully tighten the bolts .

Step 3

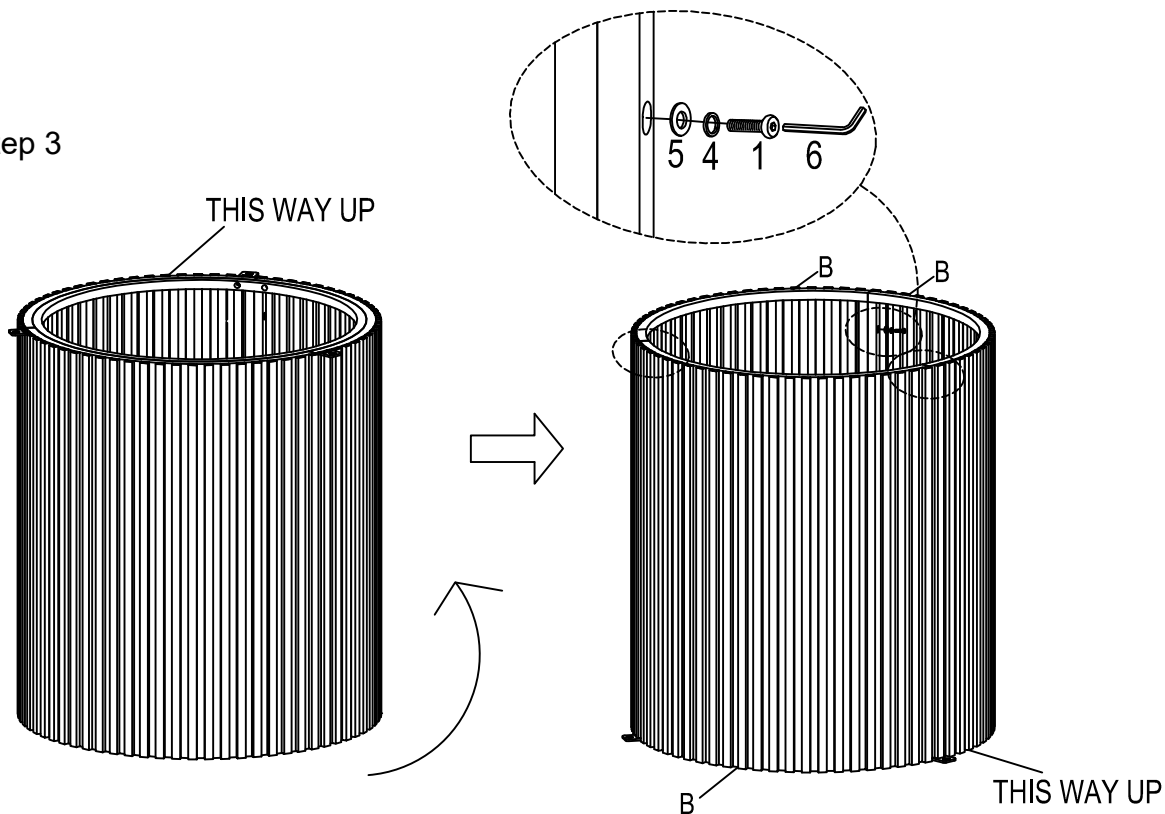

Turn the Dining Table upside down.

Note: At this stage, do not fully tighten the bolts .

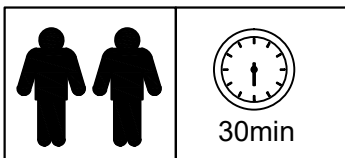

ASSEMBLY INSTRUCTIONS

Step 4

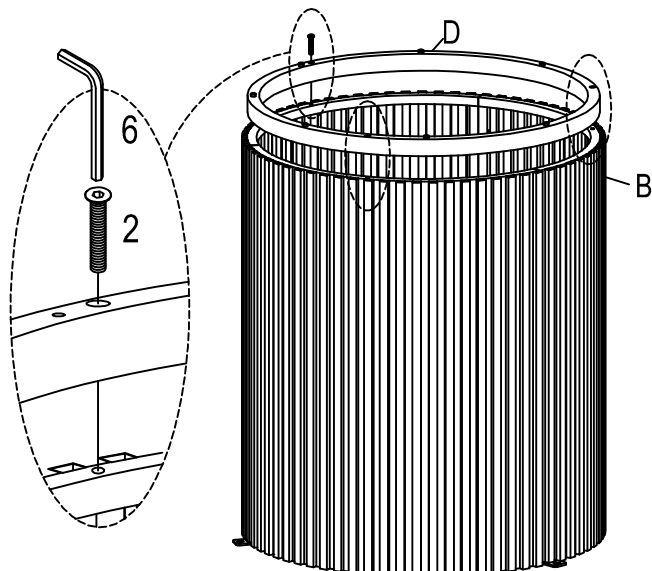

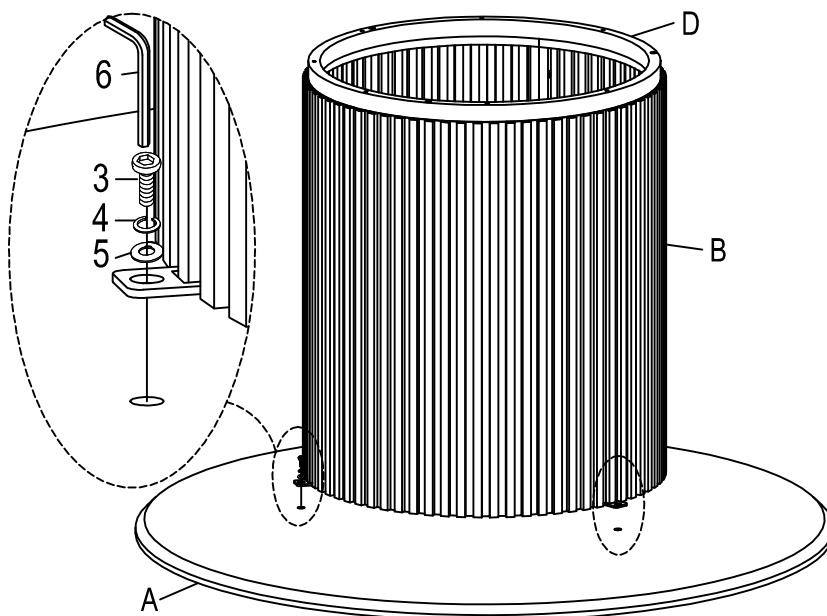

Note: At this stage, do not fully tighten the bolts .

Step 5

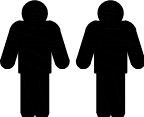

Note: At this stage, do not fully tighten the bolts .

	 30min
---	--

ASSEMBLY INSTRUCTIONS

Step 6

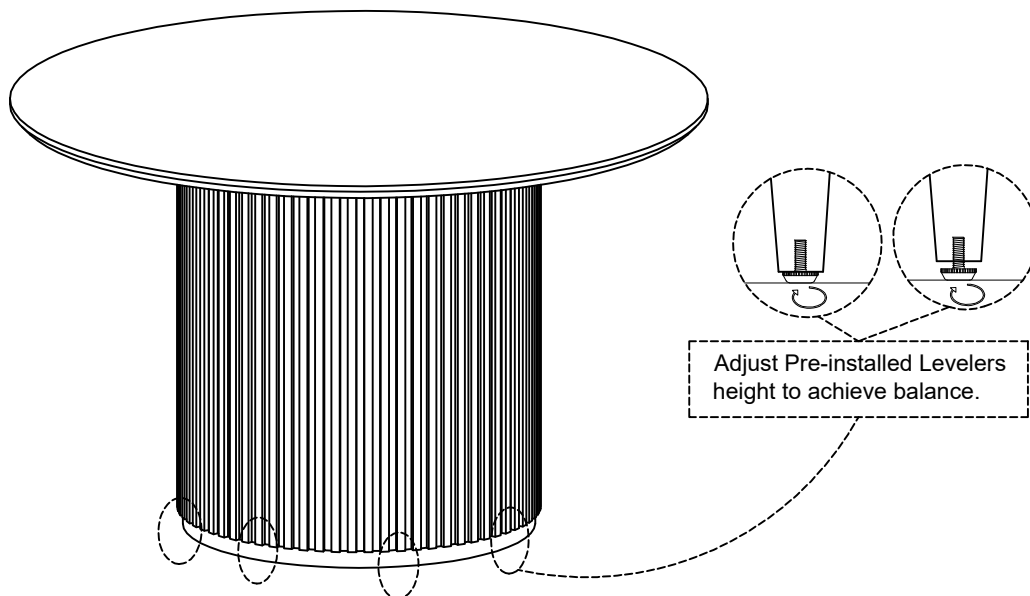



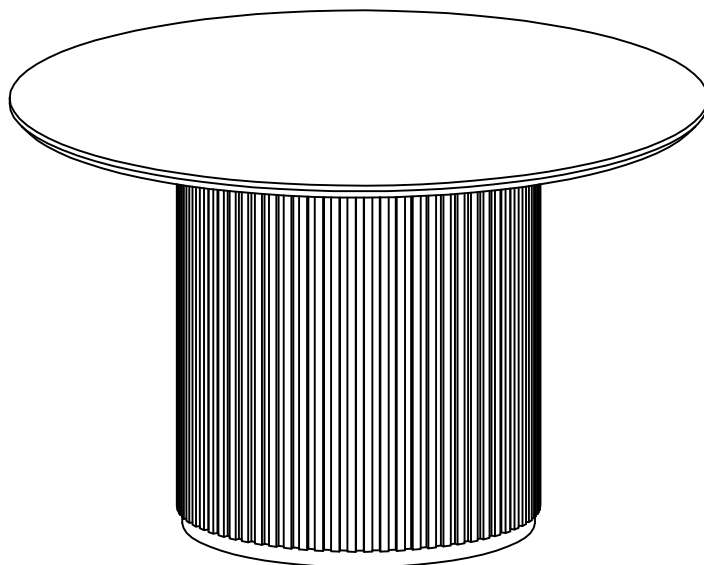

Note: Fully tighten all bolts at this step.

Step 7





ASSEMBLY INSTRUCTIONS

HARDWARE LIST

NO.	SKETCH	DESCRIPTION	QTY
1		Bolt(1/4"x2-1/8")	2 PCS
2		Bolt(1/4"x1-1/2")	4 PCS
3		Spring washer(1/4")	6 PCS
4		Washer(1/4")	6 PCS
5		Allen wrench(4mm)	1 PC

PARTS LIST

NO.	SKETCH	DESCRIPTION	QTY
A		Seat	1 PC
B		Back leg	1 PC
C		Front leg	1 PC

Step 1

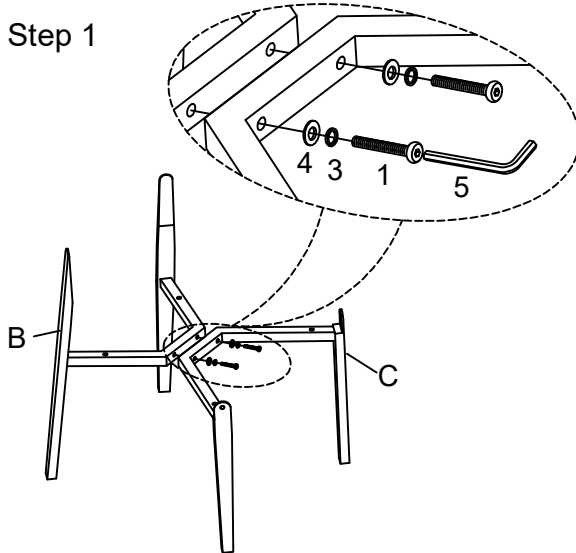

Note: Do not fully tighten the bolts at this step.

Step 2

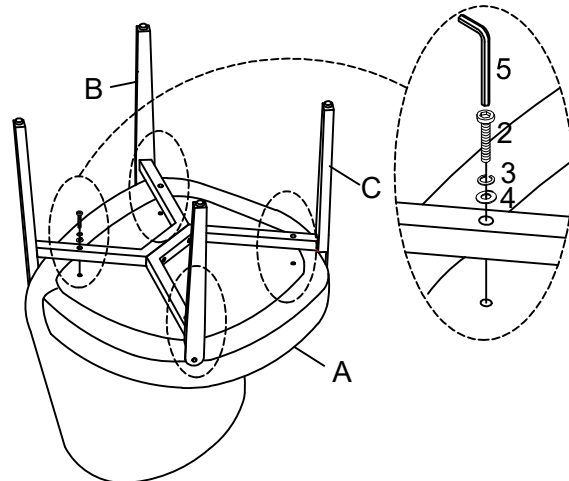

Note: Do not fully tighten the bolts at this step.

Step 3

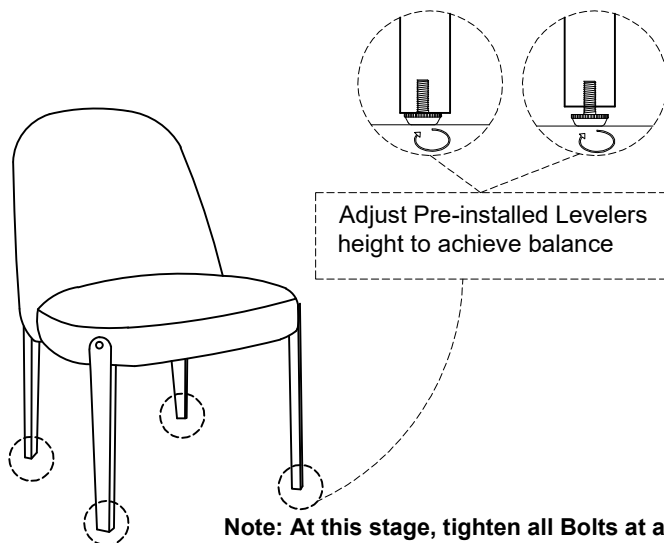

Note: At this stage, tighten all Bolts at all joints fully in a sequential manner.

Step 4

