

ASSEMBLY INSTRUCTIONS

ASSEMBLY TIPS :

1. Remove hardware from box and sort by size.
2. Please check to see that all hardware and parts are present prior to start of assembly.
3. Please follow attached instructions in the same sequence as numbered to assure fast & easy assembly.



Warning!

1. Don't attempt to repair or modify parts that are broken or defective. Please contact the store immediately.
2. This product is for home use only and not intended for commercial establishment.

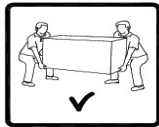

ASSEMBLY TIME | 20 MINUTES

PARTS IDENTIFICATION

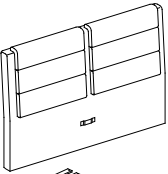
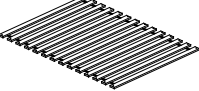

B1 (BOX 1)





AN		HEADBOARD	1 PC
BN		ROLL SLAT (14PCS)	1 SET

B2 (BOX 2)

CN		FOOTBOARD PANEL	1 PC
----	---	-----------------	------

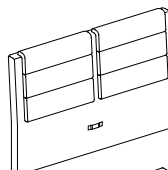
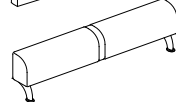

B3 (BOX 3)

DN		LEFT SIDE RAIL	1 PC
EN		RIGHT SIDE RAIL	1 PC

FN		FOOTBOARD LEGS	2 PCS
GN		BED SLAT SUPPORT WITH LEVELER	3 PCS
HN		FOOTBOARD SUPPORT WITH LEVELER	1 PC
IN		CENTER RAIL	1 PC
AN		300350Q (B1) * FROM BOX 1 HEADBOARD	1 PC
FBN		300350Q (B2 & B3) * FROM BOX 2 & BOX 3 FOOTBOARD COMPLETE	1 PC

HARDWARE IDENTIFICATION

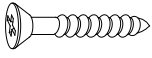
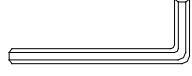
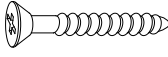
Z-B3 (BOX 3) - Hardware pack is located in 300350Q (B3)

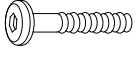
1		SHORT FLAT HEAD SCREW	12 PCS	4		SMALL ALLEN WRENCH	1 PC
2		LONG FLAT HEAD SCREW	31 PCS	5		BIG ALLEN WRENCH	1 PC
3		BOLT	3 PCS				
4							

NOTE: PHILLIPS HEAD SCREW DRIVER IS REQUIRED IN THE ASSEMBLY PROCESS. HOWEVER, MANUFACTURER DOES NOT PROVIDE THIS ITEM.

ASSEMBLY INSTRUCTIONS

300350Q (B2&B3) - BOX 2 & BOX 3

STEP 1

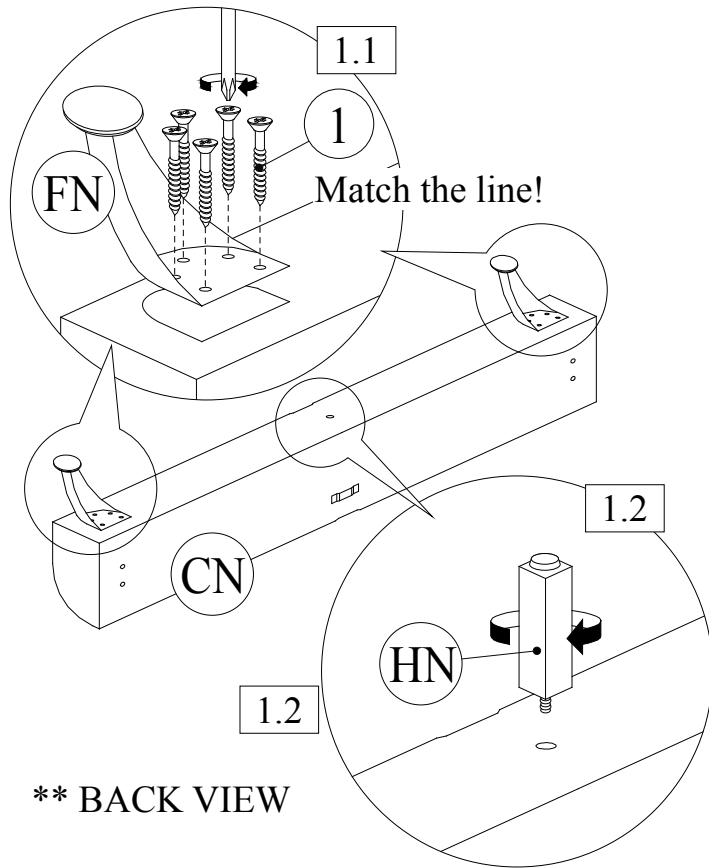

300350Q (B1-B3) - BOX 1 TO BOX 3

STEP 2

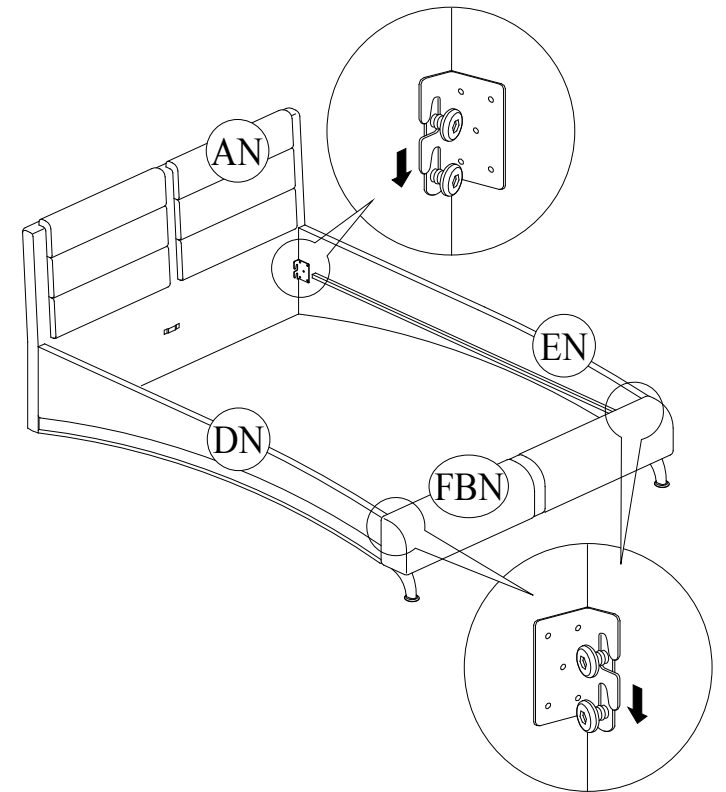

STEP 3

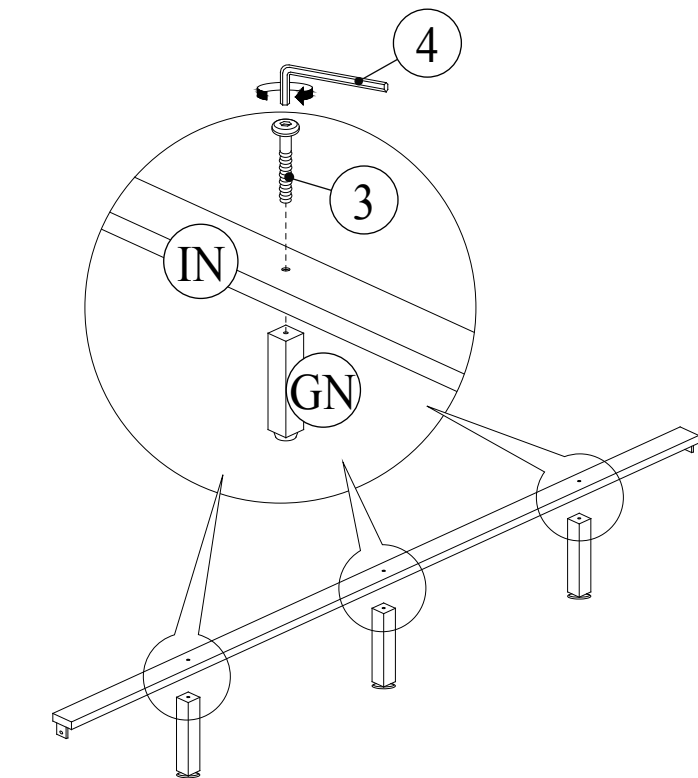

STEP 4

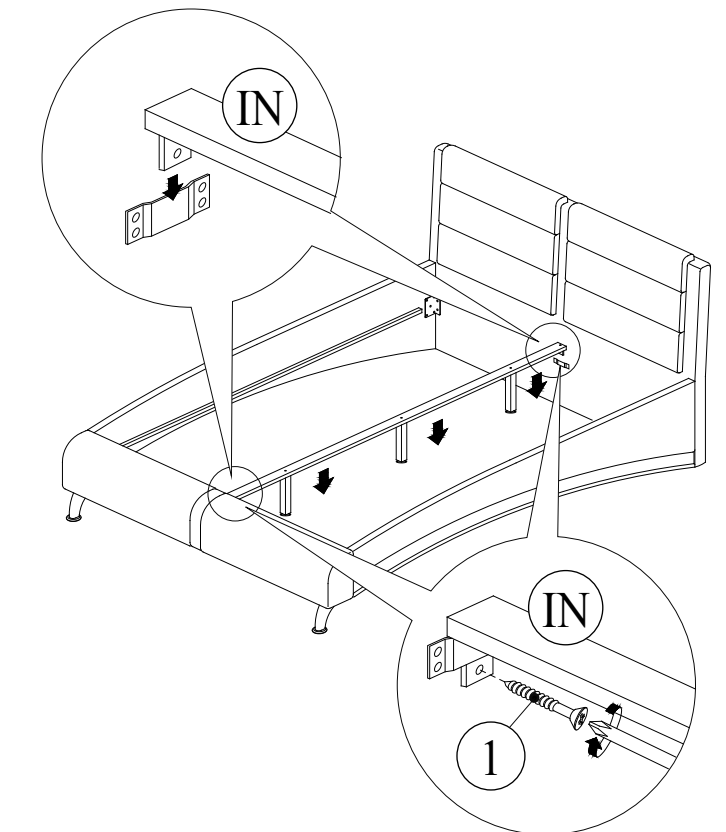

ASSEMBLY INSTRUCTIONS

STEP 5

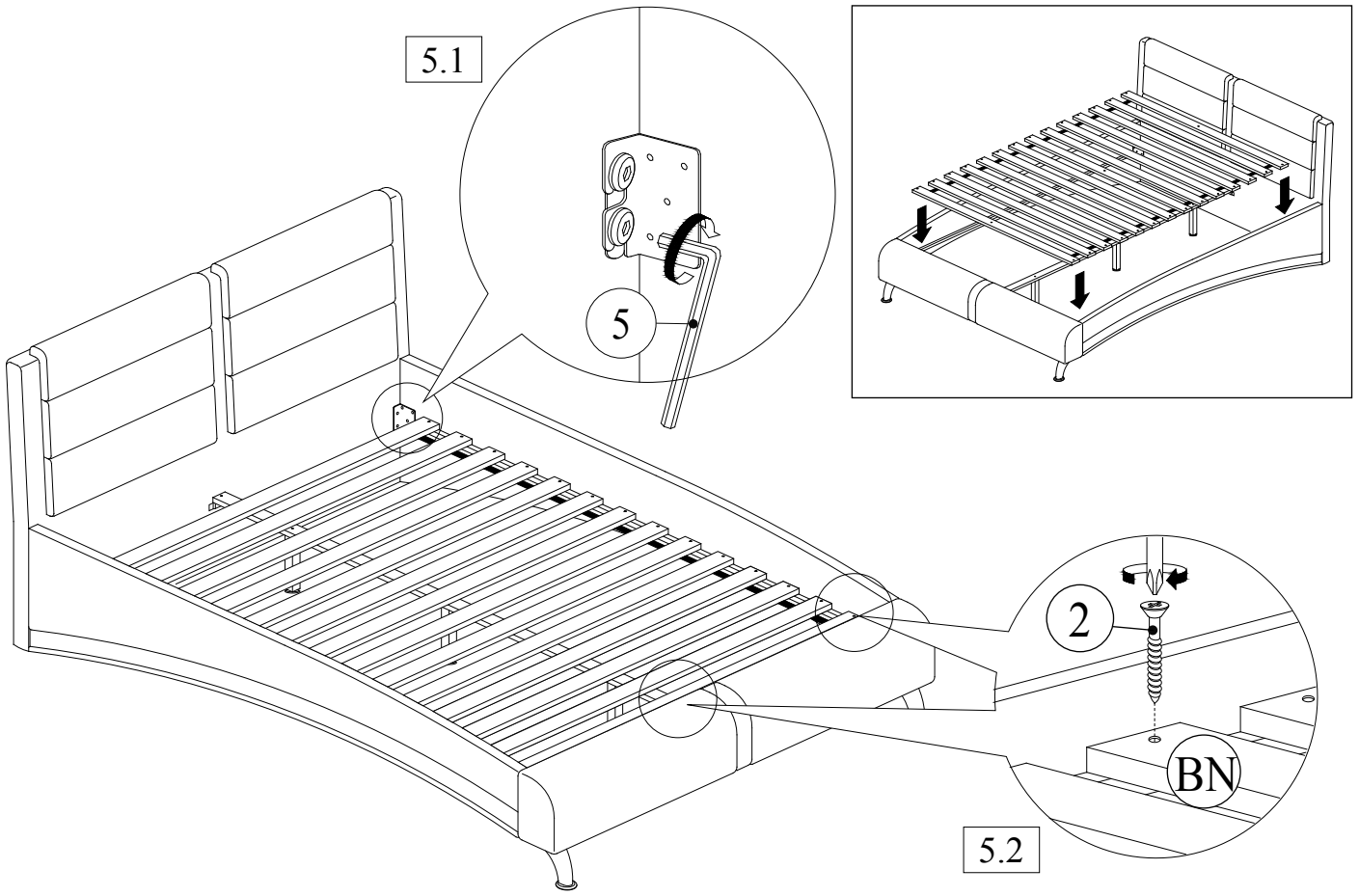

STEP 6

