

SERVICE MANUAL

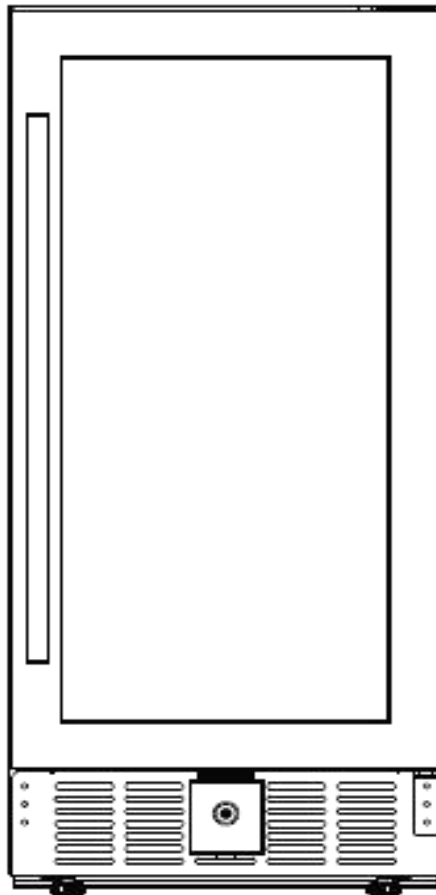

WINE&BEVERAGE COOLER

MODEL NO.: JC-46 / JC-70 / JC-75 / JC-90 /
JC-85B / JC-145B / JC-128UEX



NOTE: This is one of the basic models. The shape and specifications of your unit are subject to change.

CAUTION

**DO NOT OPERATE MACHINE
UNDER REPAIR**

Troubleshooting

This is one of the basic models. (MODEL NO.: **JC-85B**)

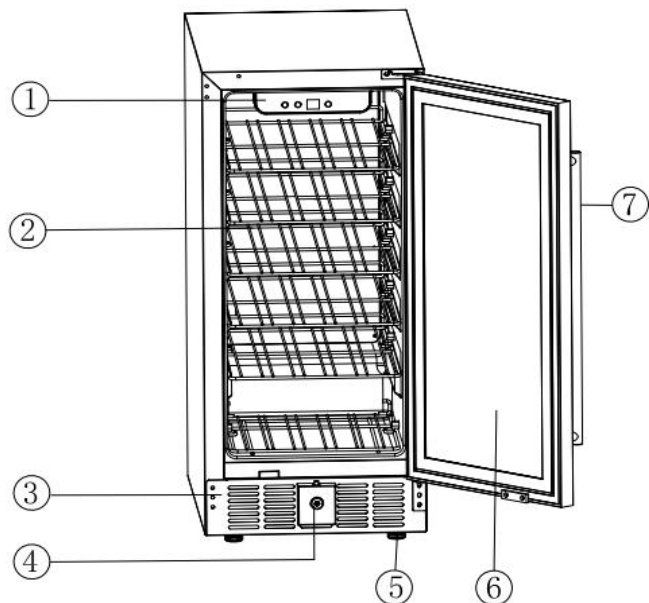

- (1) Operation Panel:
- (2) Removable Wine bottle or Can Shelf
- (3) Hot Air outlet frame
- (4) Door Lock (Optional)
- (5) Height Adjustable Feet
- (6) Glass Door
- (7) Door Handle (Need to assembled by yourself)

1. The unit does not work.

- ① Check if there is a power failure.
- ② Check if the power plug is plugged into the power outlet.
- ③ Check that the fuse has not blown in main supply circuit.

2. The unit starts making any unusual noises.

- ① Is it wobbling?
Re-level it and check if it now operates normally.
- ② Have any objects fallen behind the fridge?
If so, remove them and check if operation is now normal.
- ③ Are any containers inside the fridge vibrating or resonating?
If so, rearrange them, then check if operation has returned to normal.

3. The unit seems too warm inside.

- ① Check if the door is closing properly and if the door seal is not damaged.
- ② The fridge is overloaded.
Check if the interior circulation is not obstructed by too many goods stored.
- ③ Did you store anything hot, without first cooling it to room temperature?
- ④ Is there sufficient clearance around all sides and above the fridge?
- ⑤ Do you set the temperature too high?

4. The temperature is too cold.

- ① If temperature control setting is too cold, adjust to a warmer setting and allow several hours for temperature to adjust.

5. The condensate water overflows inside the unit and onto the floor.

- ① Check if the drain pipe and the drain hose are not clogged.
- ② Check if the drain pan is housed properly.

6. Moisture builds up on interior or exterior of the beverage center.

- ① This is normal during the periods of high humidity.
- ② Prolonged or frequent door openings.
- ③ Check door gaskets for proper seal.

7. The condensation forms on the outside of the unit.

- ① Condensation may form on the outside when the humidity level is high such as during a wet season.
This is the same result as the condensation formed when chilled water is poured into a glass.
It does not, therefore, indicate a failure, just wipe dry with a dry cloth.

8. When you wish to move the fridge.

- ① Secure all movable parts and contents. (Package them separately if necessary.)
- ② Transport the fridge only in an upright position. In any other position you may damage the compressor.

9. The compressor does not start and the unit cannot be cooled, and there will be a sound.

①Compressor strip protection, the compressor is faulty.

10. The product is maintained at room temperature and the compressor does not work.

①Check the compressor wiring.

NOTE: Before contacting professional service, please review the troubleshooting list that includes common occurrences that are not the result of a defect in workmanship or materials.

If the problem is still not solved, please contact us via Amazon Message or call customer service number: 213-4467172 or 661-4358826.

Thank you for purchasing this product! If you have any questions about the product, such as missing parts, damaged products, product assembling, and operation, please contact us via **Amazon Message** or customer service number: **213-4467172** or **661-4358826**.

IMPORTANT

Please call our customer service department for any consulting:

213-4467172

661-4358826

(8:30am - 5:30pm P.S.T.)

DATED PROOF OF PURCHASE IS REQUIRED FOR WARRANTY SERVICE.

AVIS

Veuillez appeler le service à la clientèle pour toutes questions au:

213-4467172

661-4358826

(8:30am - 5:30pm P.S.T.)

PREUVE D'ACHAT ORIGINALE REQUISE POUR SERVICE DE GARANTIE.

IMPORTANTE

Sólo hay que llamar nuestro departamento de servicio al cliente en caso de tener preguntas o inquietudes:

213-4467172

661-4358826

(8:30am - 5:30pm P.S.T.)

SE REQUIERE PRUEBA DE COMPRA CON FECHA PARA SERVICIO BAJO GARANTÍA.

**Address: ROWAN ELECTRIC APPLIANCE LLC
28407 Ascent Way, Santa Clarita, CA 91350**