









# ASSEMBLY INSTRUCTION FULL BED

Caution: Please read instructions thoroughly before unpacking assembly parts. Sharp, exposed staple tips can cause injury, therefore, for your protection, please remove any exposed staples used in packing.

1. We recommend that you should assemble this product with the assistance of another person; this will make assembly easier, and will help to eliminate damage the product or injury to persons during assembly.
2. Be sure to check all packing materials carefully for small parts that may have come loose inside the carton during shipment.
3. Please do not over tighten screws or bolts.
4. Please put all parts on a non-abrasive floor before assembly, and follow the assembly steps to assemble your newly purchased product correctly and efficiently.

PARTS LIST			
NO.	PART DESC.	PART	QTY
A	HEADBOARD		1 pc
B	HB - LEG (L / R)		2 pcs
C	HB - STRETCHER		1 pc

HARDWARE LIST				
NO.	HARDWARE DESC.	PART	SIZE	QTY
1	ALLEN BOLT		M6 x 30mm	4 pcs
2	ALLEN BOLT		M8 x 35mm	6 pcs
3	SPRING WASHER		M8	10 pcs
4	FLAT WASHER		M8 x 18mm	10 pcs
5	ALLEN KEY		M4	1 pc
6	ALLEN KEY		M5	1 pc

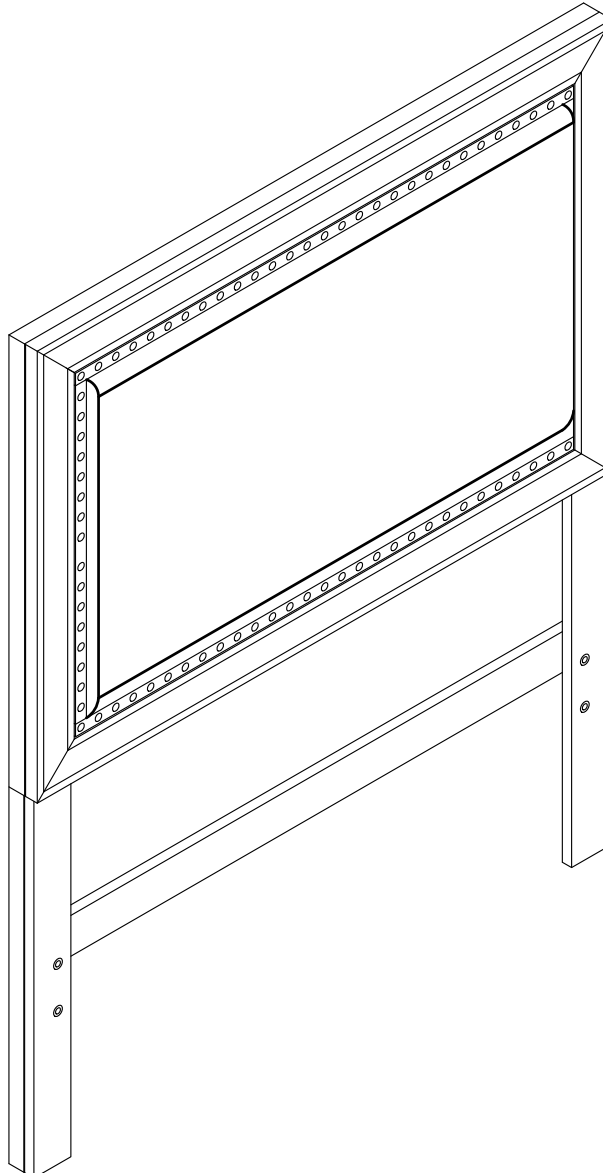

# ASSEMBLY INSTRUCTION FULL BED

STEP  
1

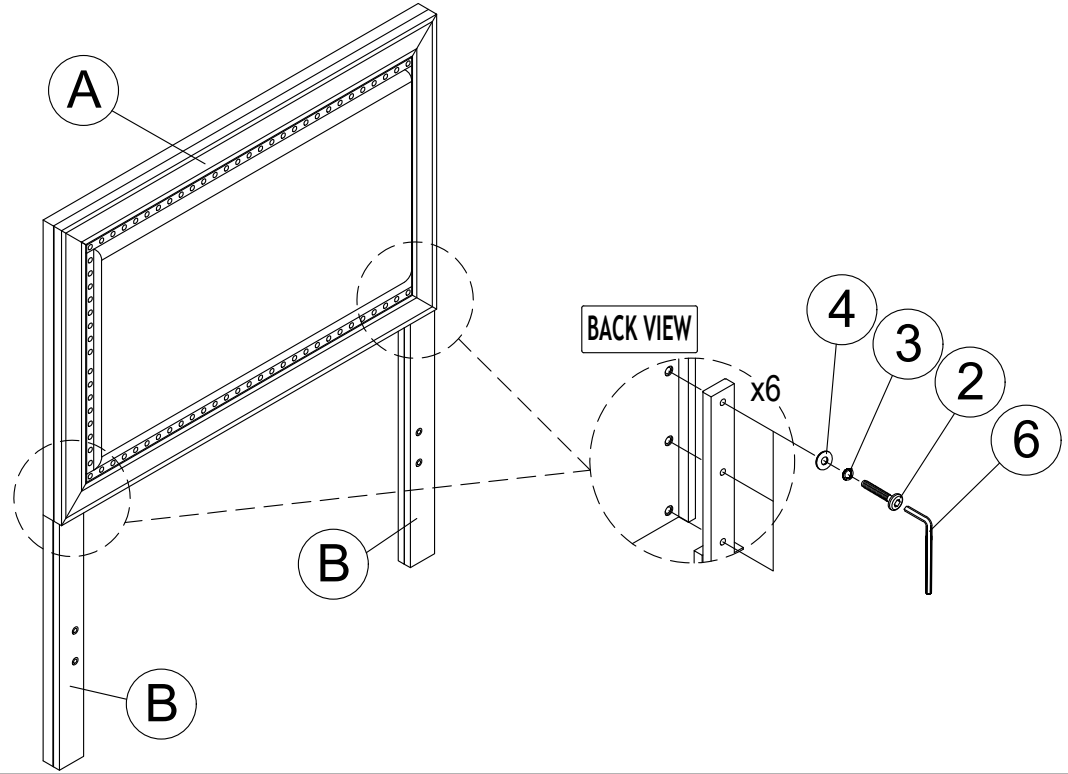
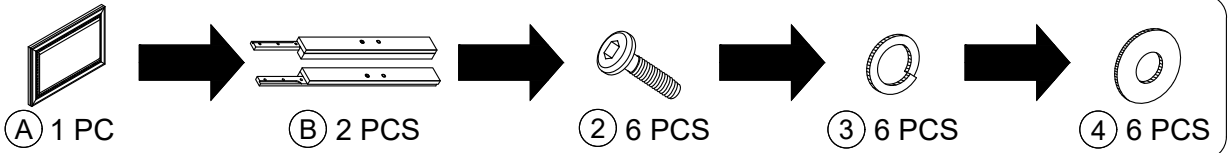



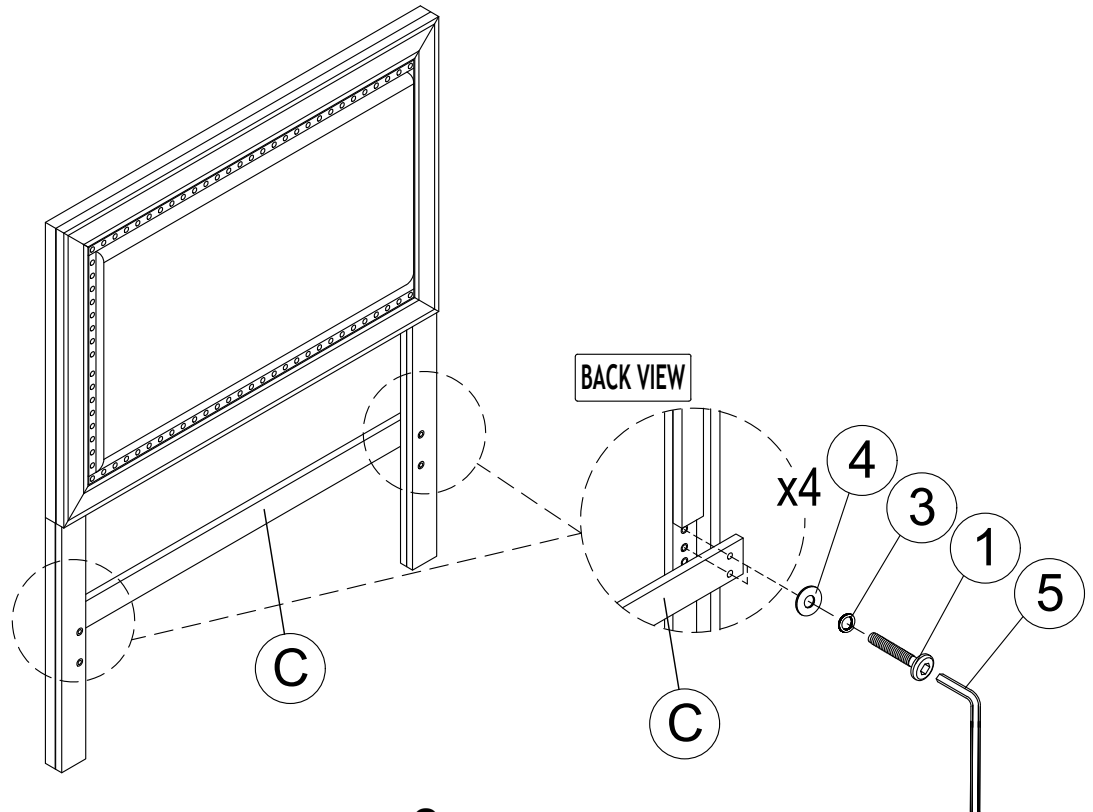
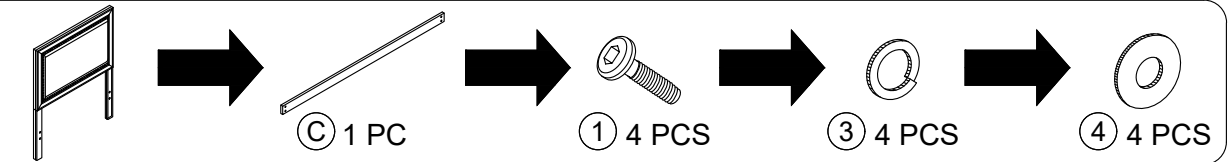



STEP  
2







# ASSEMBLY INSTRUCTION FULL BED

Caution: Please read instructions thoroughly before unpacking assembly parts. Sharp, exposed staple tips can cause injury, therefore, for your protection, please remove any exposed staples used in packing.

1. We recommend that you should assemble this product with the assistance of another person; this will make assembly easier, and will help to eliminate damage the product or injury to persons during assembly.
2. Be sure to check all packing materials carefully for small parts that may have come loose inside the carton during shipment.
3. Please do not over tighten screws or bolts.
4. Please put all parts on a non-abrasive floor before assembly, and follow the assembly steps to assemble your newly purchased product correctly and efficiently.

PARTS LIST			
NO.	PART DESC.	PART	QTY
A	HEADBOARD		1 pc
B	FOOTBOARD		1 pc
C	SIDE RAIL		2 pcs
D	SLAT		4 pcs
E	BUNFOOT		2 pcs
F	VERTICAL LEG		4 pcs

HARDWARE LIST				
NO.	HARDWARE DESC.	PART	SIZE	QTY
1	ALLEN BOLT		M6 x 20mm	8 pcs
2	FLAT WASHER		M8 x 18mm	8 pcs
3	ALLEN KEY		M5	1 pc
4	PANHEAD SCREW		M4 x 25mm	8 pcs

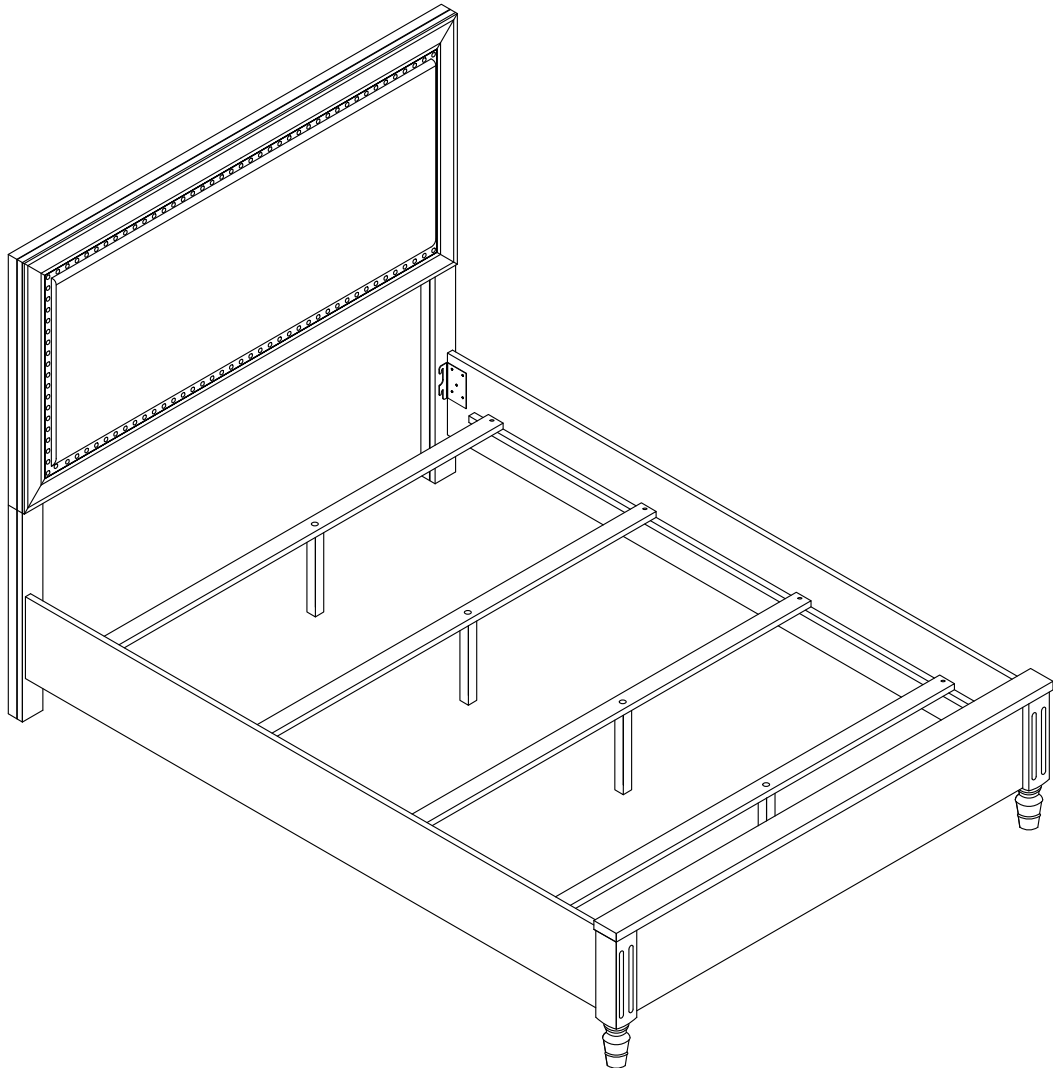

# ASSEMBLY INSTRUCTION FULL BED

**STEP**  
**1**

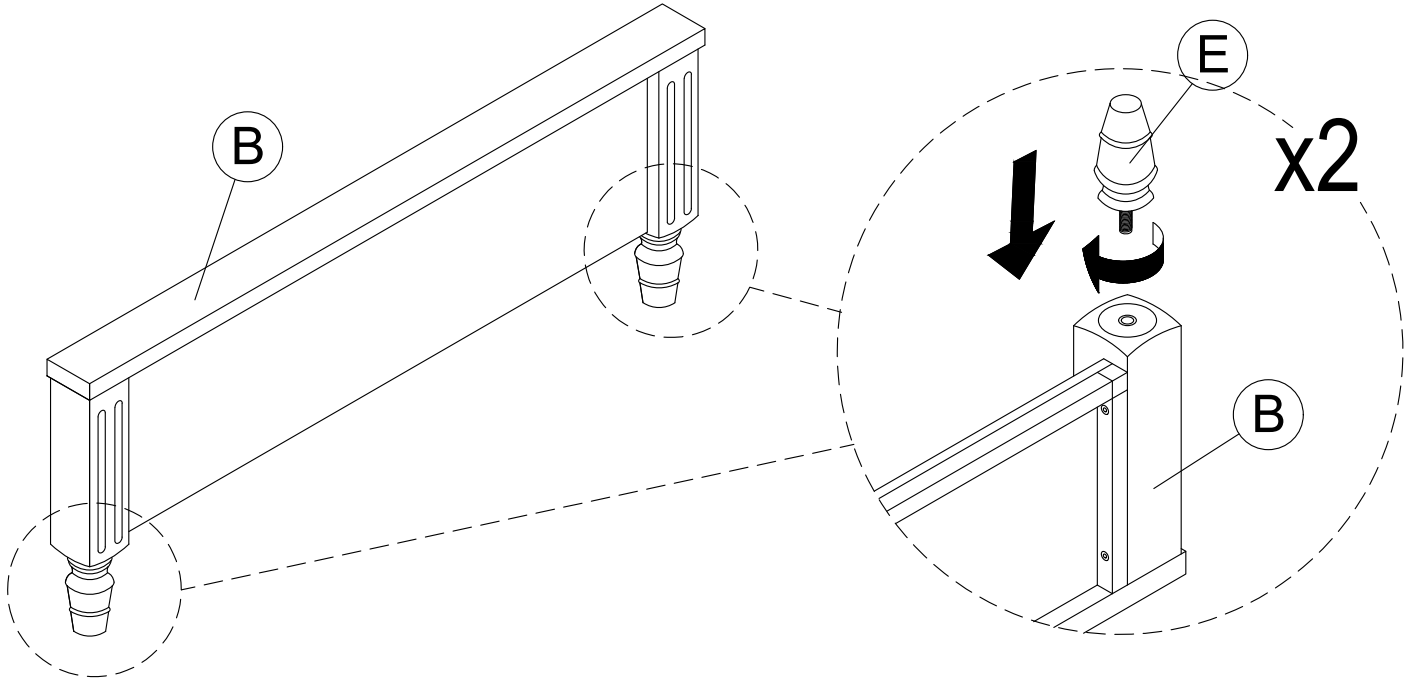
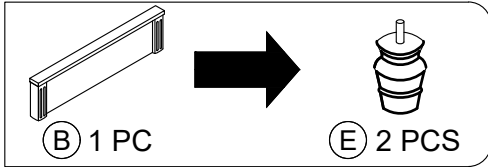

**STEP**  
**2**

