

NOTICE







- * Please make sure that you have all parts indicated and they are in good condition before you begin assembly of this item. Refer to part list and hardware list below for guidance.
- * This item should be assembled on a soft surface to prevent scratching the finish during assembly.
- * This item may require periodic tightening.
- * If you are having difficulty, our friendly Customer Care team is always here to help.

PREPARATION

- * Before beginning assembly of product, make sure all parts are present. Compare parts with part contents list and hardware contents list.
- * If any part is missing or damaged, do not attempt to assemble the product.
- * Estimated Assembly Time: 20 minutes.
- * Tools Required for Assembly (included): Allen Key

CARE AND MAINTENANCE

- * Spot clean using a mild water-free solvent. Only a professional cleaner should undertake a complete overall cleaning.
- * The use of steam or water-based cleaners may cause excessive shrinking or staining.

PIECE	DESCRIPTION	PICTURE	QUANTITY
A	Headboard		1X
B	Metal Leg		2X
HW1	Hex Nut 6 mm		4X
HW2	Flat Washer 8,5 mm		12X
HW3	Philips bolt 8 x 1 x 30 mm		4X
HW4	Philips bolt 6 x 1 x 25 mm		4X

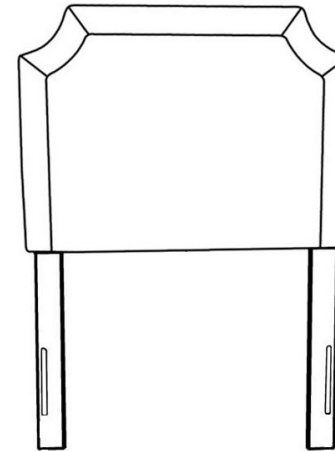

Weight Capacity: 275 lbs

Warning: Do not stand on headboard

Warning: Do not over torque bolts



PREPARATION

- * Before beginning assembly of product, make sure all parts are present. Compare parts with part contents list and hardware contents list.
- * If any part is missing or damaged, do not attempt to assemble the product.
- * Estimated Assembly Time: 20 minutes.
- * Tools Required for Assembly (included): Allen Key
- * If you are having difficulty, our friendly customer care team is always here to help.

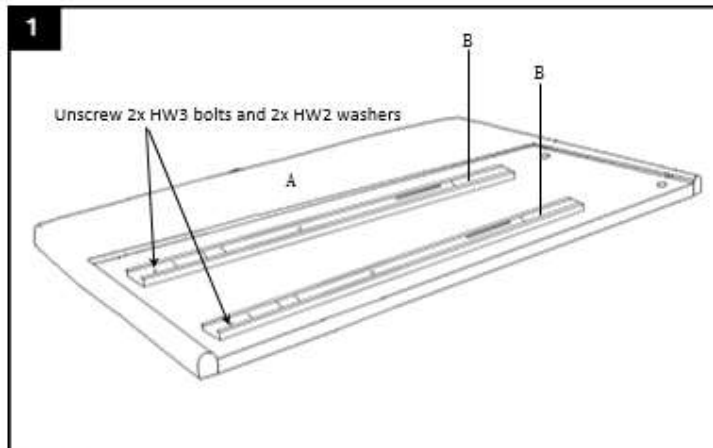

Step 1
Remove the legs (B) from the back of the headboard (A) by unscrewing the 2 Philips bolts (HW3) and 2 washers (HW2). The bolts and washers need to be re-used to attach the legs in the correct position in Step 2.

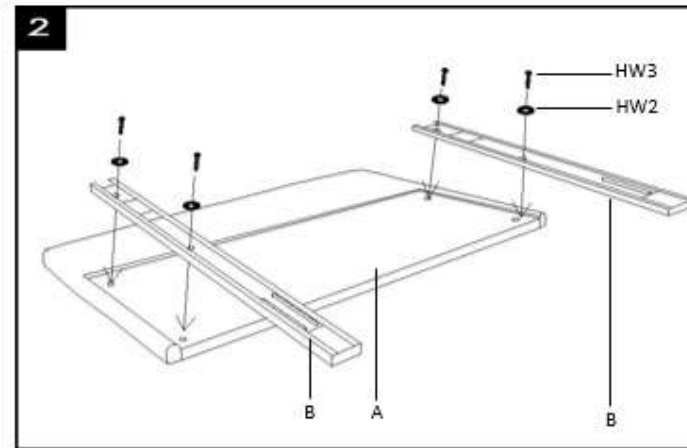

Step 2
Attach the two legs (B) to the headboard (A) using 4 Philips bolts (HW3) and 4 washers (HW2). The vertical slots at the lower part of the leg must be facing the outside of the bed.

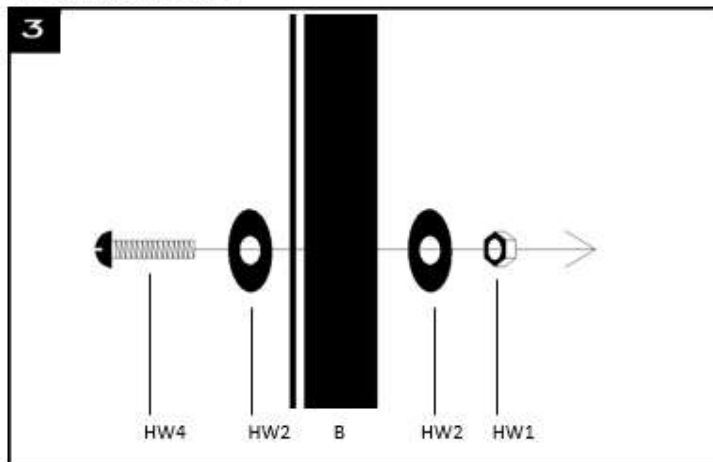

Step 3
The hardware needed to connect the headboard to the bed frame are 4 Philips bolts (HW4), 8 washers (HW2), and 4 nuts (HW1)

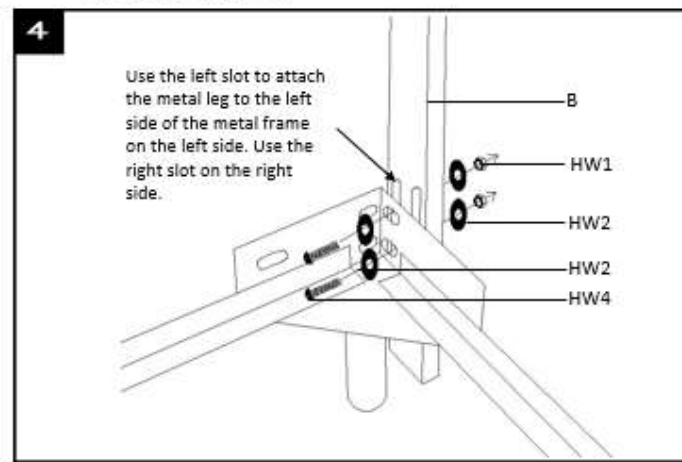

Step 4
Attach the legs of the headboard (B) to the bed frame or mounting bracket by fixing them together through the 2 holes in the bed frame and the vertical slot in the leg using 4 small bolts (HW4), 8 washers (HW2) and 4 nuts (HW1)