

ASSEMBLY INSTRUCTIONS

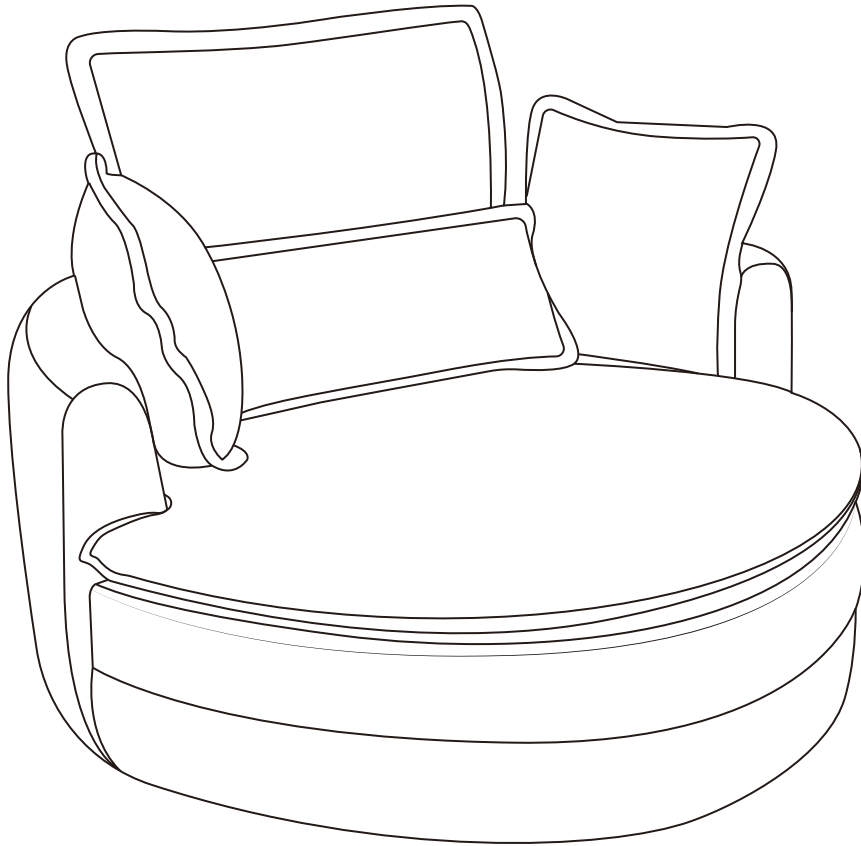







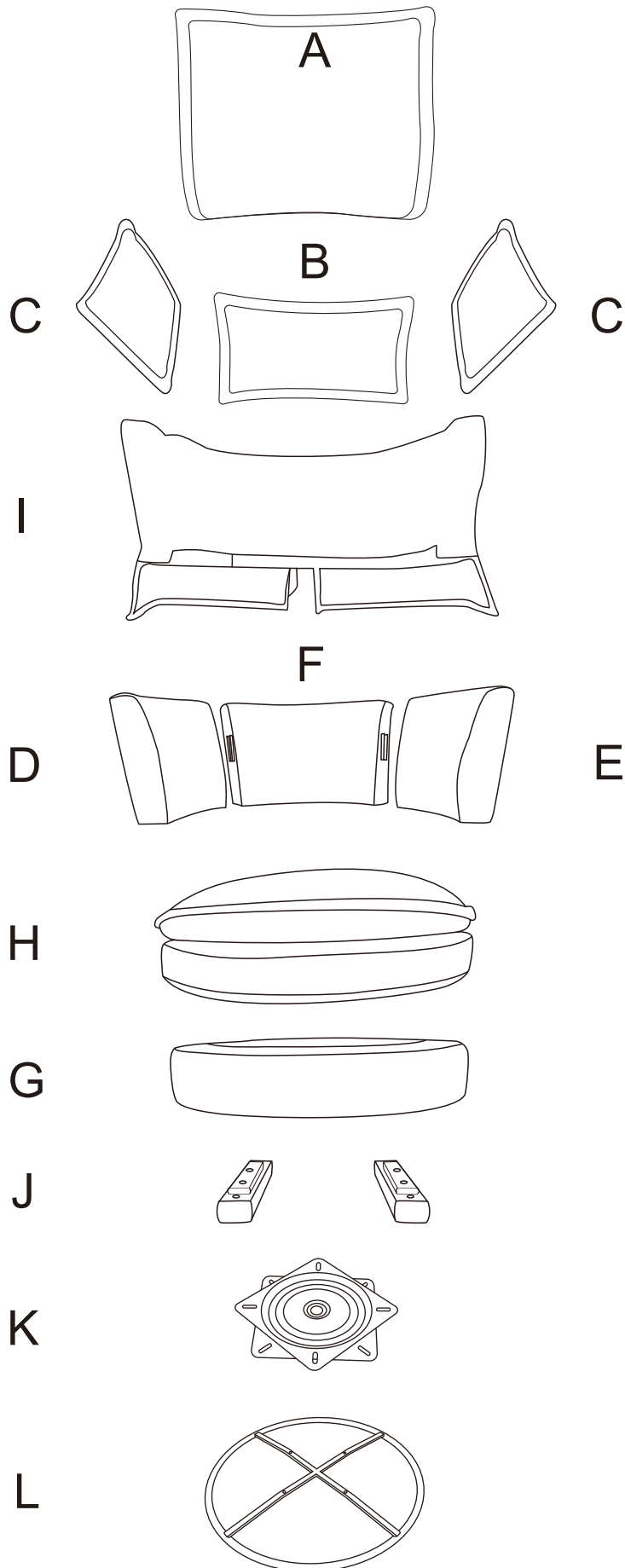

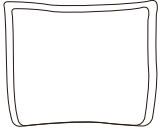
Thank you for your purchase.

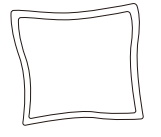
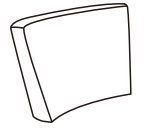
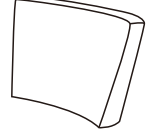
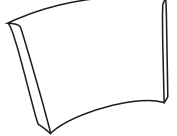
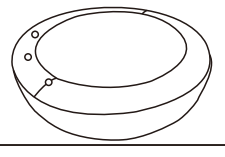
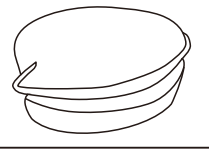
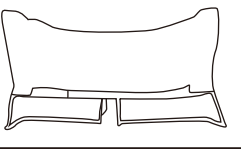
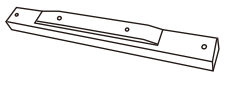
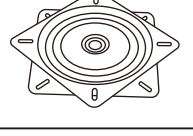
If you have difficulty with assembly or find a part is missing or damaged, please don't hesitate to contact us for solution. Customer Service team will work hard to put a smile back on your face.

Components

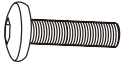

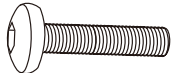
NO	PARTS	QTY	DESCRIPTION
A		1PC	Lay-up Bag
B		1PC	Lumbar Pillow
C		2PCS	Armrest Bag
D		1PC	Left Armrest
E		1PC	Right Armrest
F		1PC	Back Frame
G		1PC	Seat Frame
H		1PC	Seat Cushion
I		1PC	Back Cover
J		2PCS	Wooden Crossbar
K		1PC	Turntable
L		1PC	Round Foot

NO	PARTS	QTY	DESCRIPTION
M	 M8X30MM	10+1PCS	Shim
N	 M6X65MM	4+1PCS	Screw
O	 M8X65MM	4+1PCS	Screw
P	 M8X45MM	6+1PCS	Screw
Q	 M6X16MM	4+1PCS	Screw
R		1PC	Allen Wrench

STEP 1

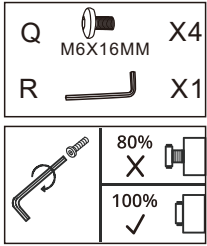

The convex side of the round foot faces up. Rotate the turntable to cross and separate the upper and lower iron plates, aligning the four holes in the lower iron plate with the four screw holes on the round foot.

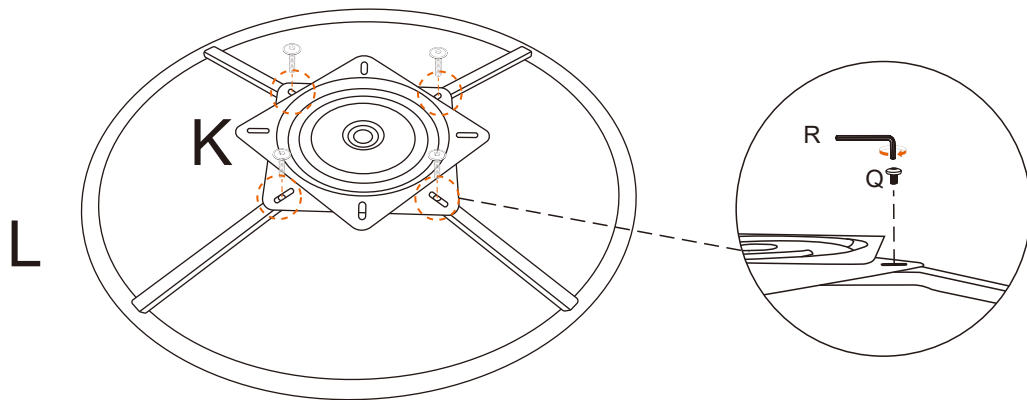

STEP 2

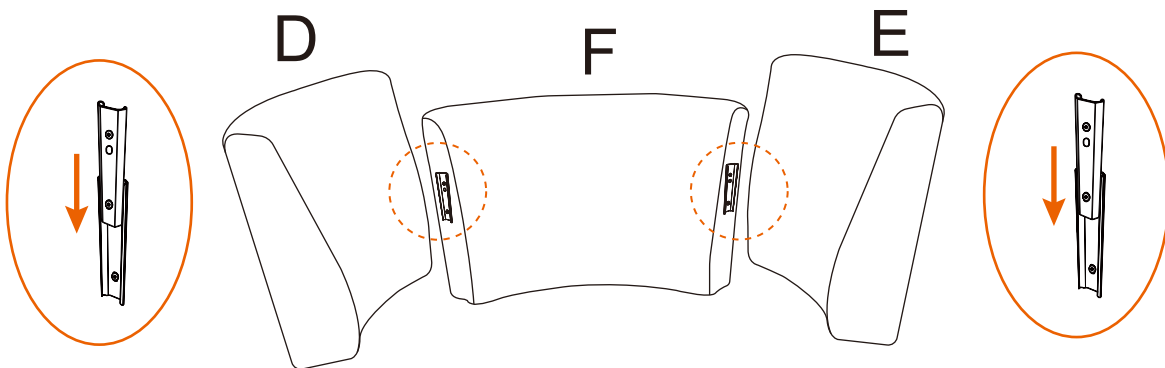

STEP 3

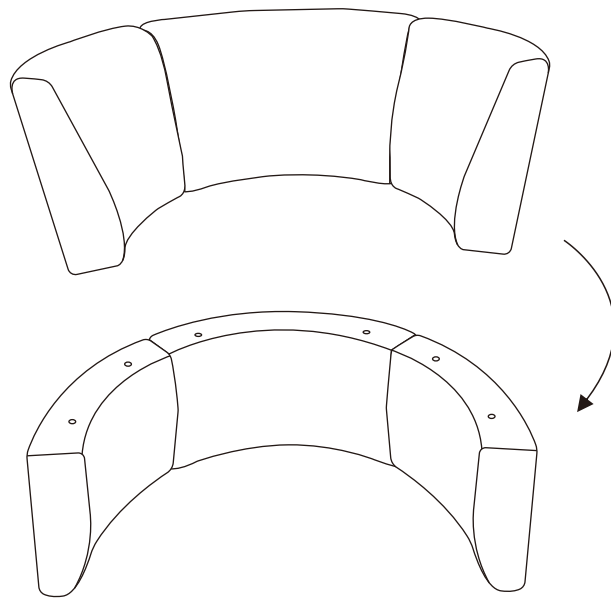

Flip 180°

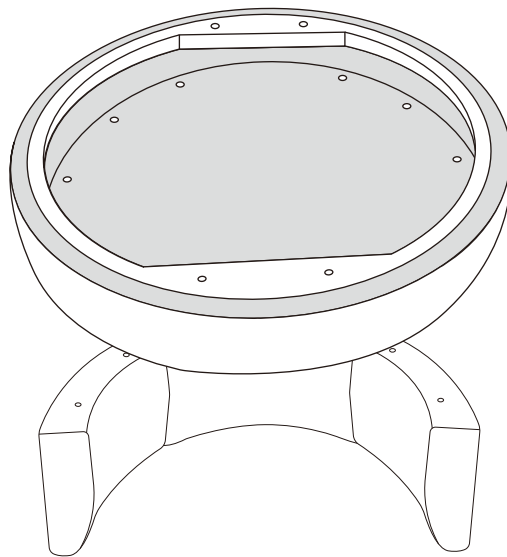

STEP 4

G





Place the seat frame directly above the armrest

STEP 5

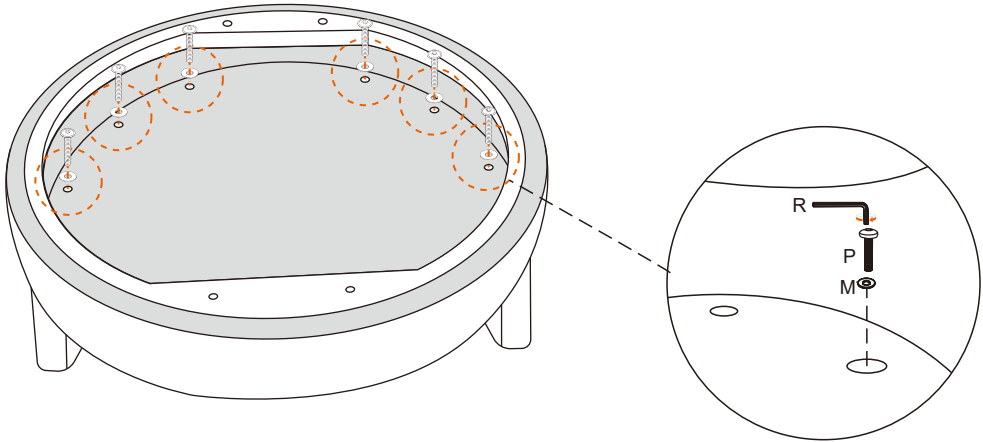
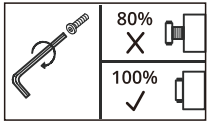
- P  X6
M8X45MM
- R  X1
- M  X6
M8X30MM



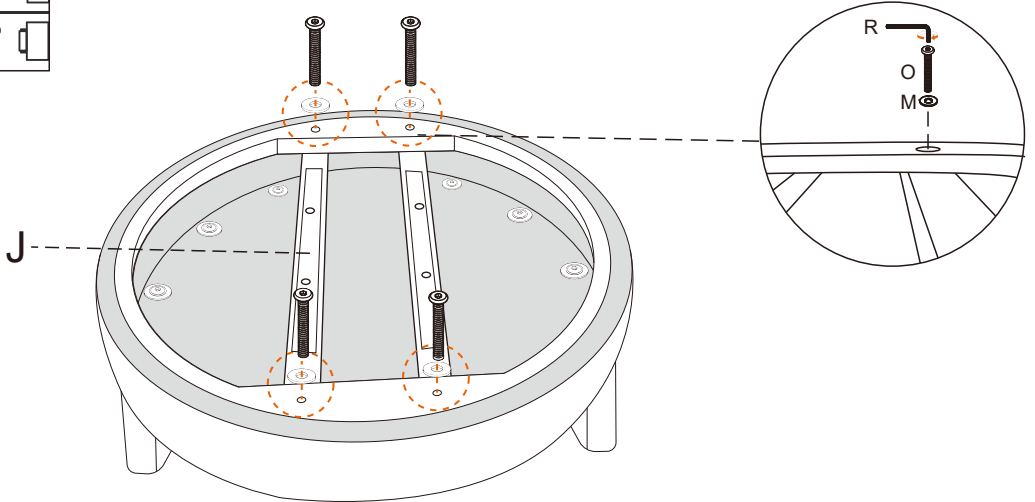
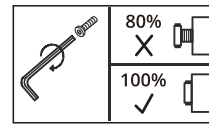

STEP 6

- O  X4
M8X65MM
- R  X1
- M  X4
M8X30MM

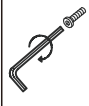

STEP 7

N		X4
R		X1

	80%	
	100%	

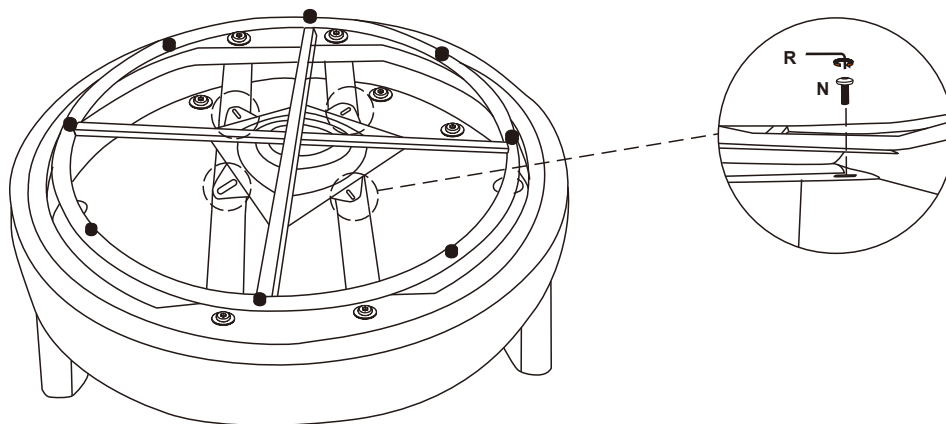

STEP 8

Put the cover I on one armrest first, then smooth out the two corners of the backrest and place it on the other armrest. Finally, attach the Velcro on cover I to the inner and outer sides of the backrest and armrest respectively.

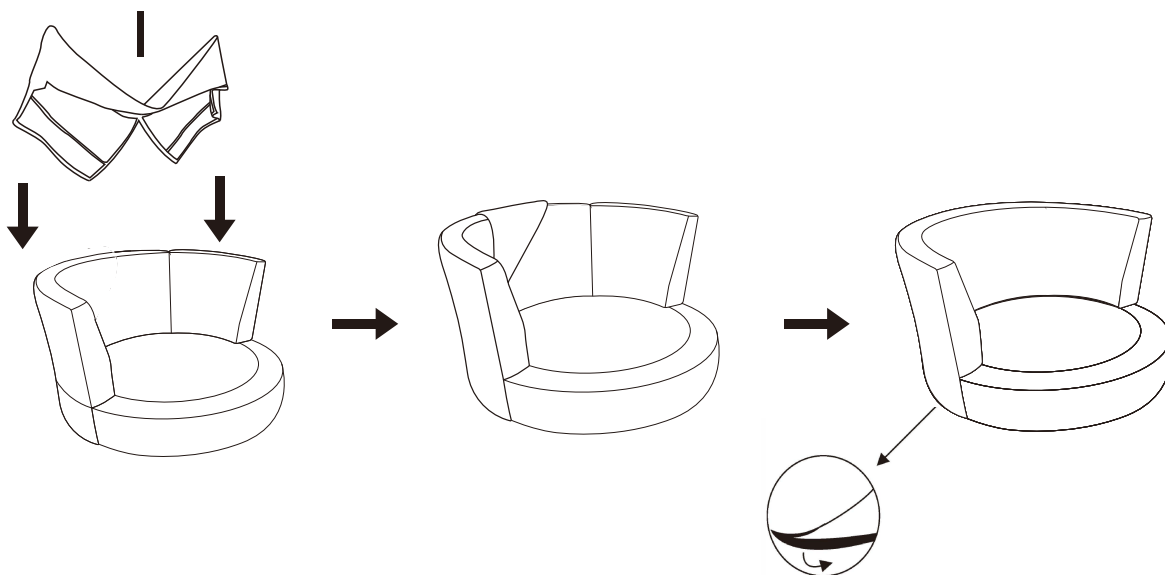

STEP 9

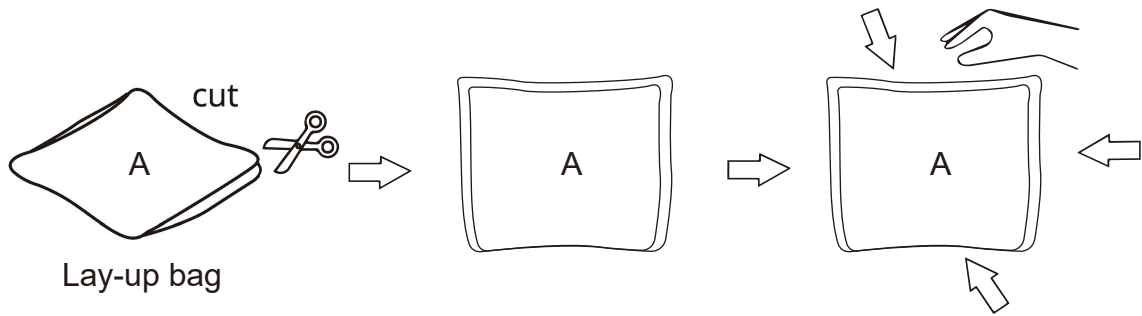

Pat the (A) and wait about 36 hours for full recovery.

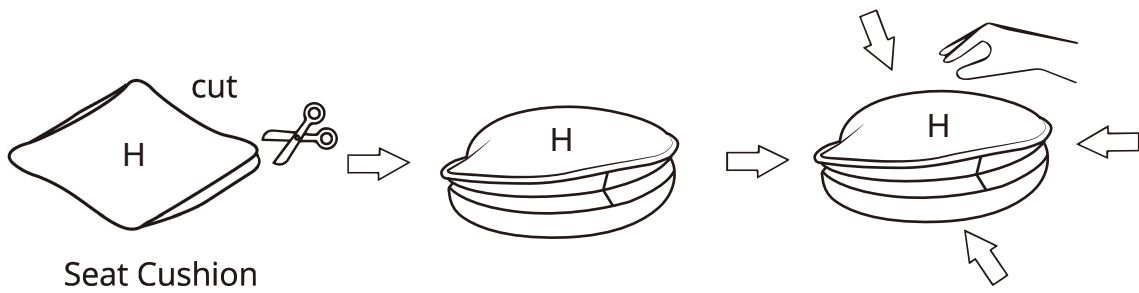

Pat the (H) and wait about 36 hours for full recovery.

STEP 10

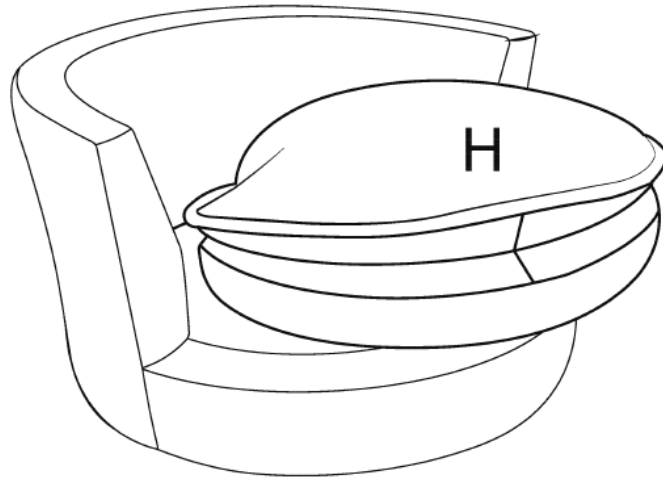

STEP 11

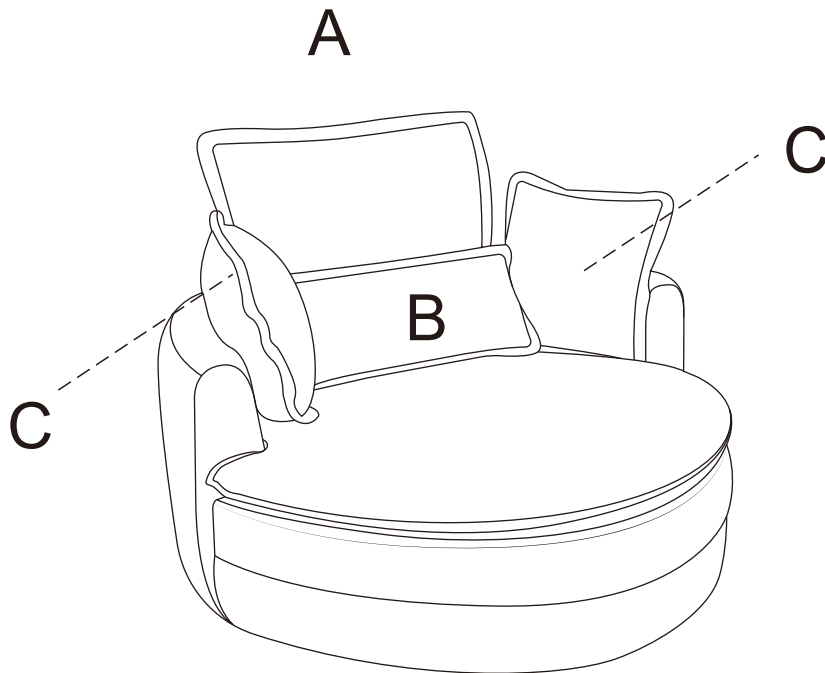

FINISHED

