

Assembly Instructions

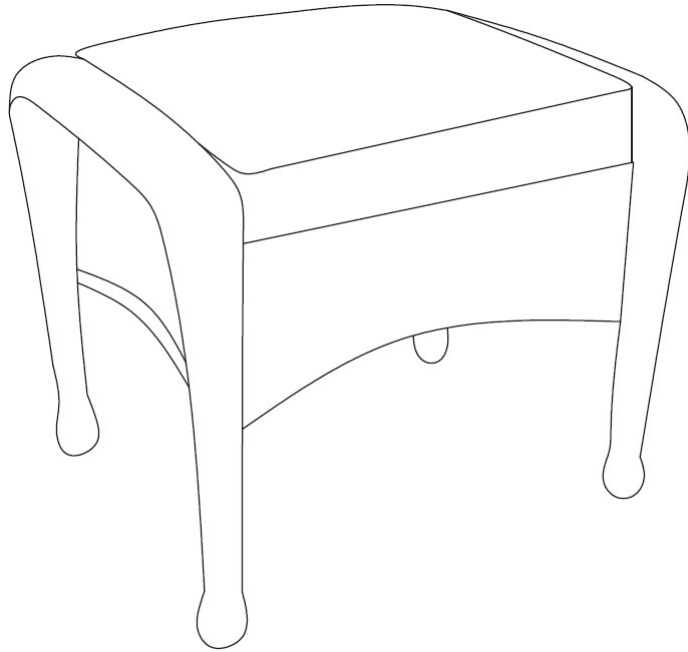





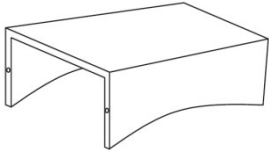

For any missing hardware, damaged parts and other problems. Email us

***Don't fully tighten all the bolts till the very end!**

PRE-ASSEMBLY PREPARATION:

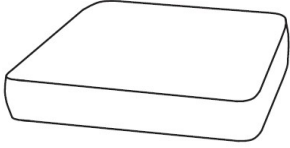
- Please read through the instructions before beginning assembly.
- Clear out the space for assembly and lay out all of the parts based on the Parts List, extra room will allow you to easily determine if all the pieces are present.
- Keep small parts and pieces away from children until fully assembled.

Part no.	Part	QTY	Image	Part no.	Part	QTY	Image
A	Seat panel	1		D	Bolt (M6*38mm)	4	
B	Leg	2		E	Washer M6	4	
C	Cushion	1		F	Allen wrench	1	

Step 1: Attach legs B to seat panel A with 4pcs bolts D and 4pcs washers E, using Allen wrench F. Note: Please fully tighten all the bolts.



Bolt D x 4
M6*38mm



Washer E x 4

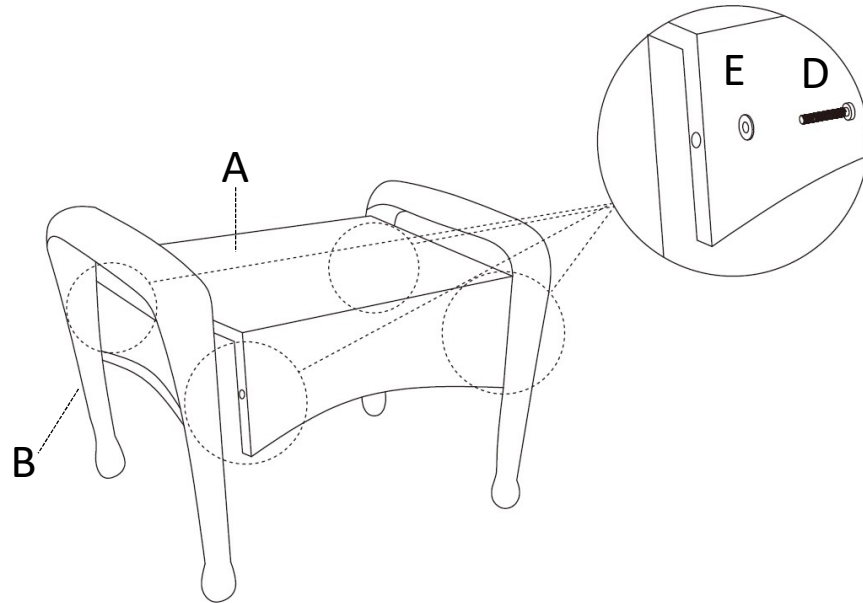

Step 2: Put the cushion C onto the seat. Assembly is now complete and the product is ready for use.

