

Wood Platform Bed

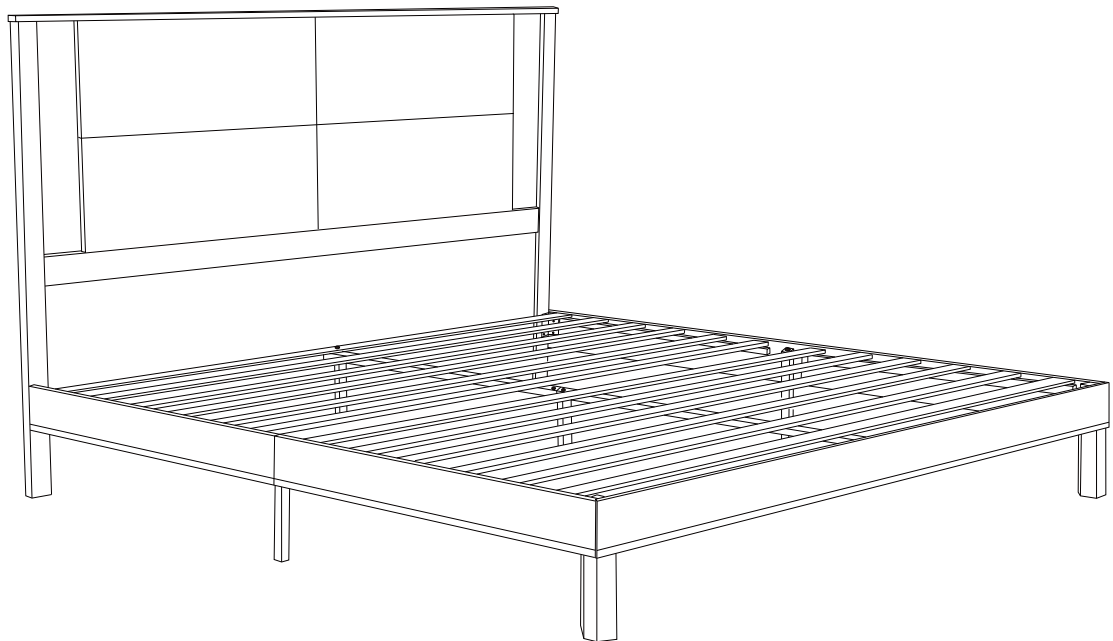

Dear Customers,

Thank you for purchasing our product. Please read this instruction manual carefully after receiving this product. It will help you assemble this product quickly, safely and correctly. You can keep this manual for future reference.

! IMPORTANT

Please follow the instruction manuals and use a pad to protect the product during your assembly.

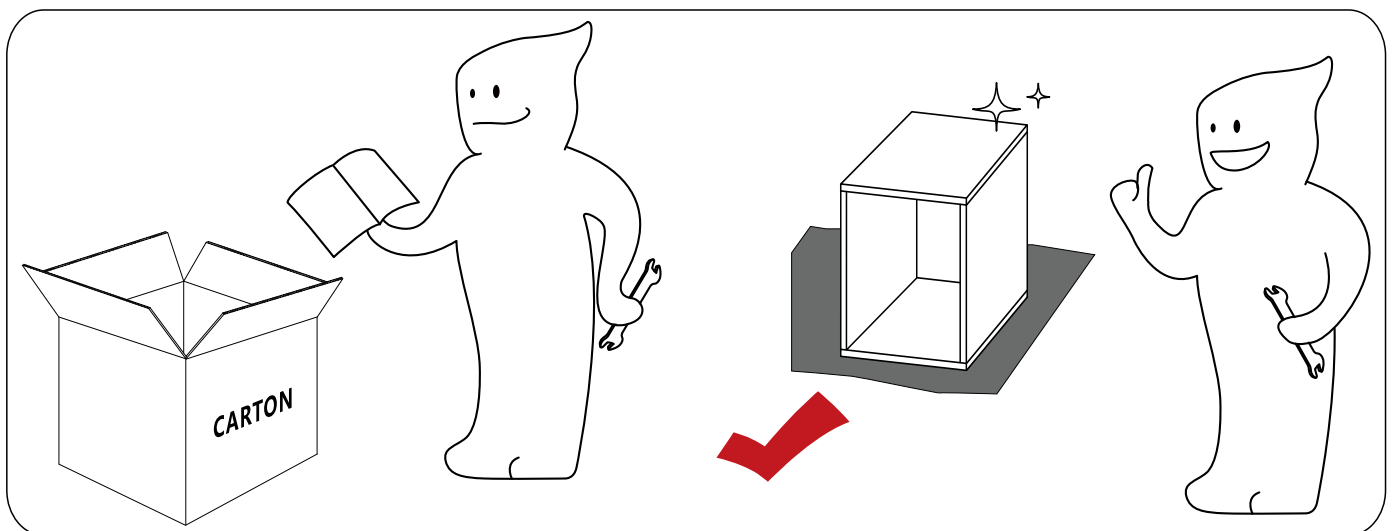
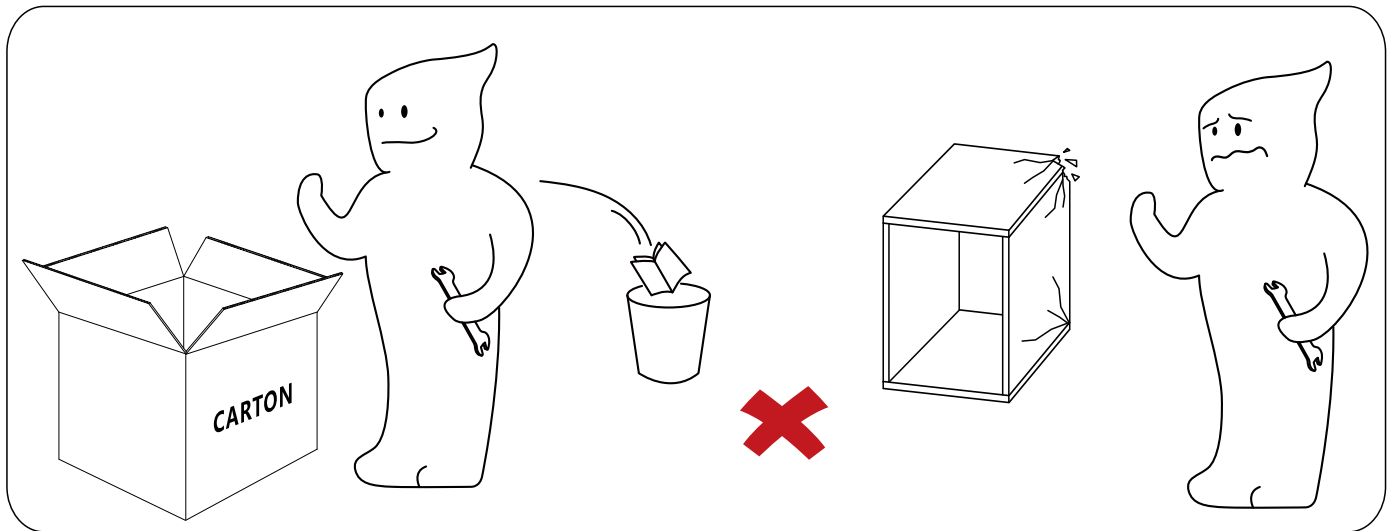











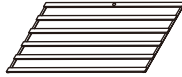

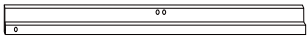
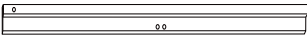
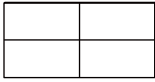
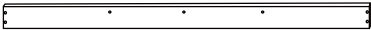

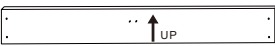
Note:

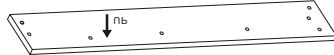
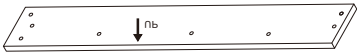
1. Should be assembled on flat ground to keep balance.
2. Before completing the installation, do not tighten the screws.
3. **Finally, tighten all the screws manually.**



For easier and better assembly, **2** or more adults are required.

ASSEMBLY INSTRUCTIONS

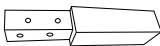
ALPHABETICAL NUMBERING	DESCRIBE	ILLUSTRATION	NUMBER
A	Slat		1pc
B	Slat		1pc
C	Up headboard		1pc
C1	Headboard leg		1pc
C2	Headboard leg		1pc
C3	Middle headboard		1pc
C5	Down headboard		1pc
C6	Connector wood		3pcs
E	Footboard		1pc
F1	Side panel		2pcs
F2	Side panel		1pc
F3	Side panel		1pc
G	Support bar		1pc
H	Support bar		1pc
I	Support bar		1pc
J	Support wood		4pcs
K	Support leg		2pcs
L	Support leg		2pcs
M	Wood leg		1pc
M1	Wood leg		1pc

ASSEMBLY INSTRUCTIONS

Ruler-Use this ruler to help correctly identify the screws.

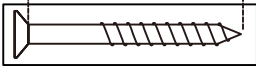

The length of the screw is measured from the rod part excluding the screw cap (30mm screw shown).

ALPHABETICAL NUMBERING	DESCRIBE	ILLUSTRATION	NUMBER
X	Connector plate 100x2 mm		2pcs
D	Connector plate 30x2 mm		4pcs
T	Connector plate 70x2 mm		2pcs
O	Sponge-cushion		4pcs
P	Washer φ8x18x1.5 mm		46pcs+1pc
P1	Washer φ6x18x1.5 mm		18pcs
Q	Wrench M6		1pc
R	Screw M8x50 mm		9pcs
R1	Screw M8x35 mm		5pcs
R2	Screw M8x30mm		12pcs
R3	Screw M8x14mm		20pcs+1pc
R4	Screw M6x25 mm		6pcs
R5	Screw M6x14 mm		16pcs
S			6pcs
S1			6pcs

1

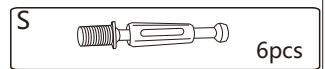
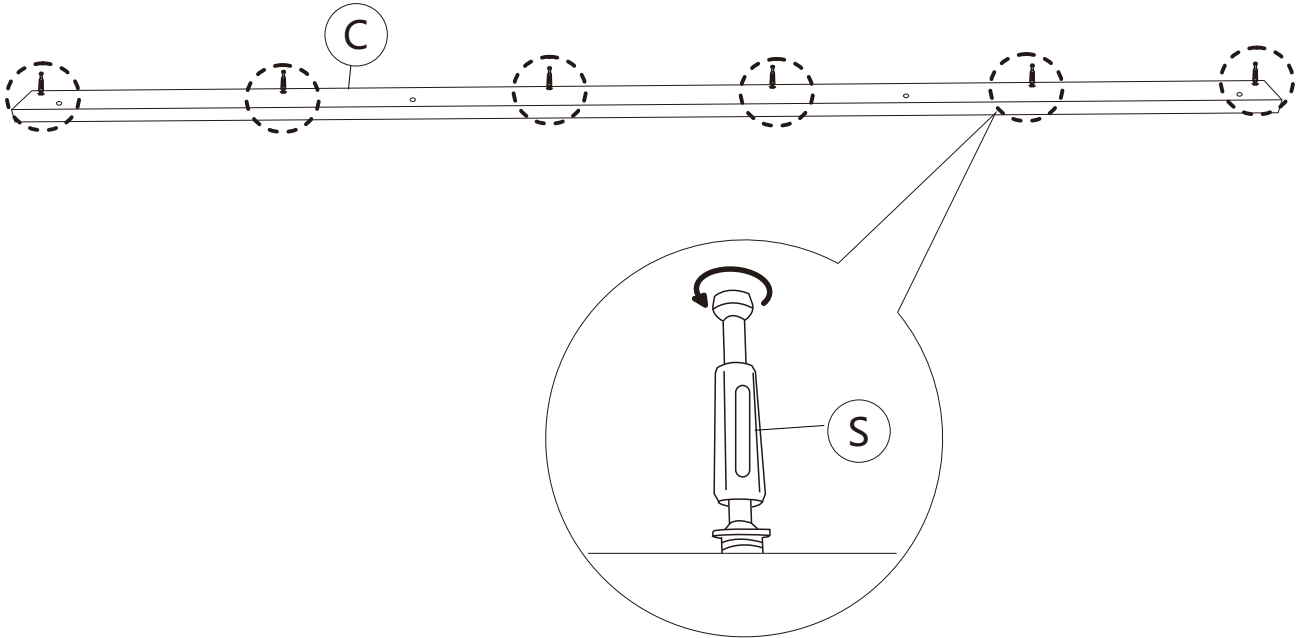



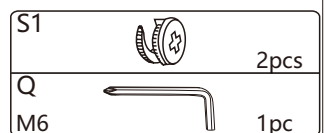
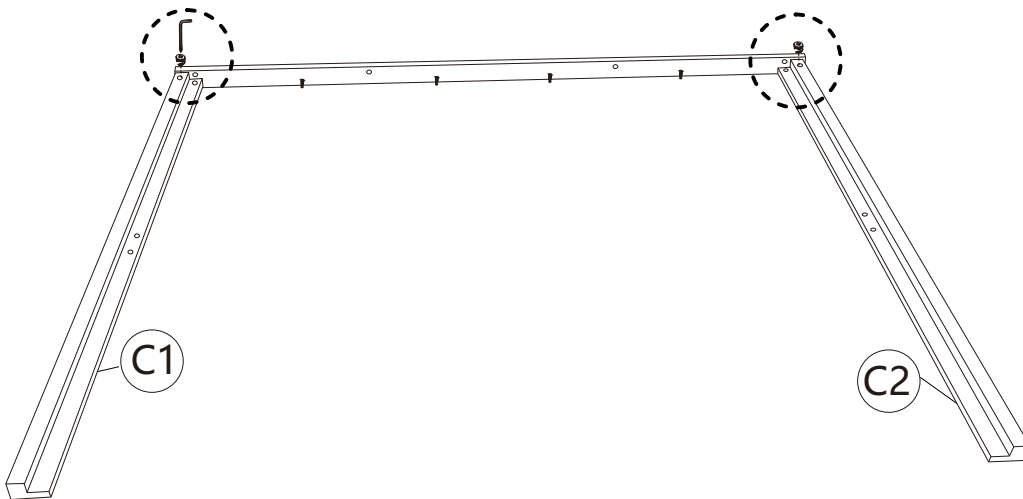
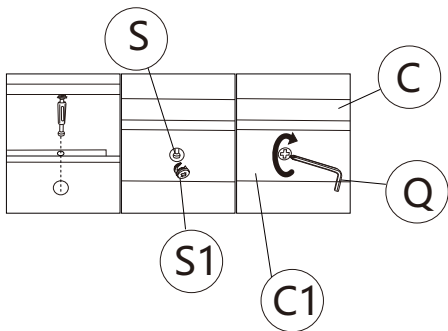

2

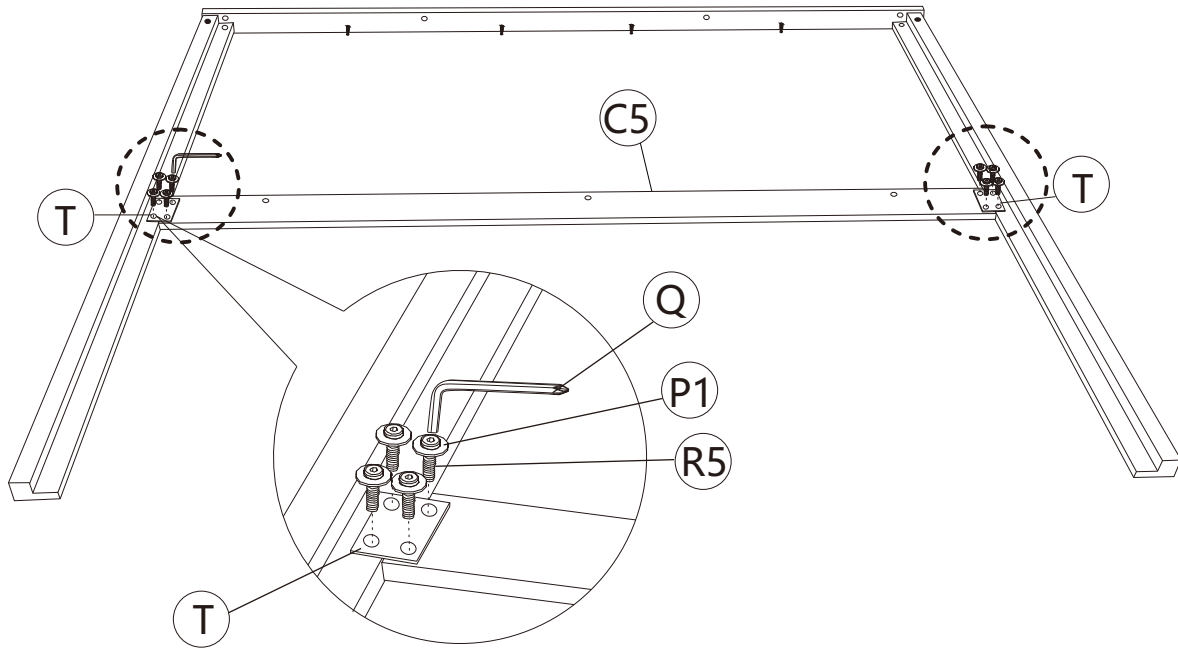

ASSEMBLY INSTRUCTIONS



3

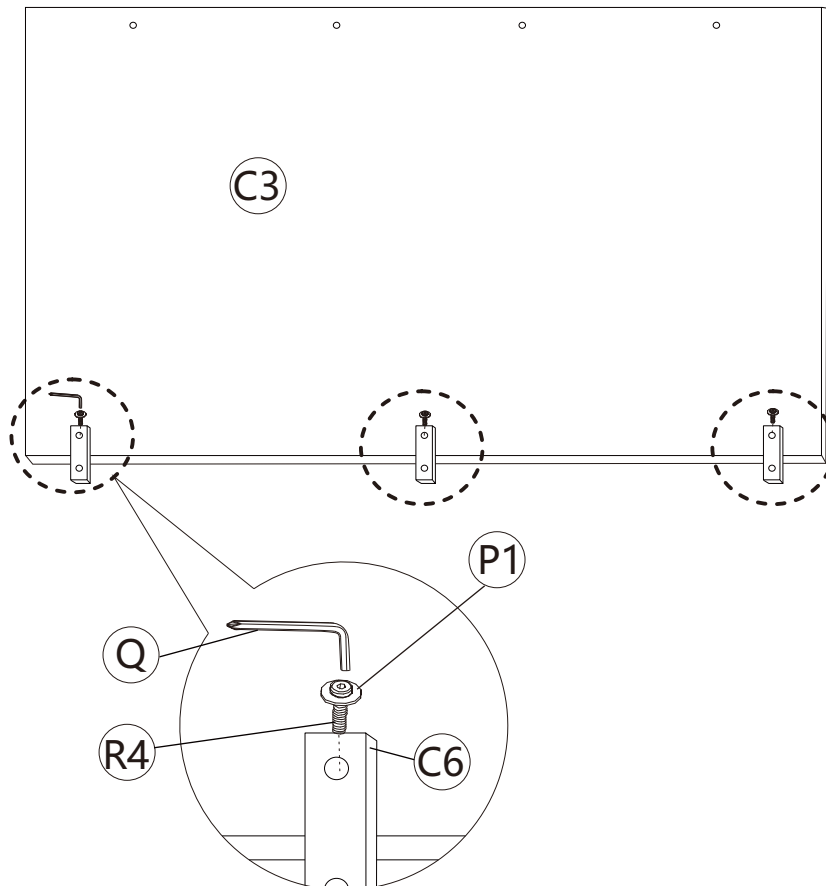

T	70x2 mm		2 pcs
R5	M6x14 mm		8 pcs
P1	φ6x18x1.5 mm		8 pcs
Q	M6		1 pc

4





R4	M6x25 mm		3 pcs
P1	φ6x18x1.5 mm		3 pcs
Q	M6		1 pc

ASSEMBLY INSTRUCTIONS

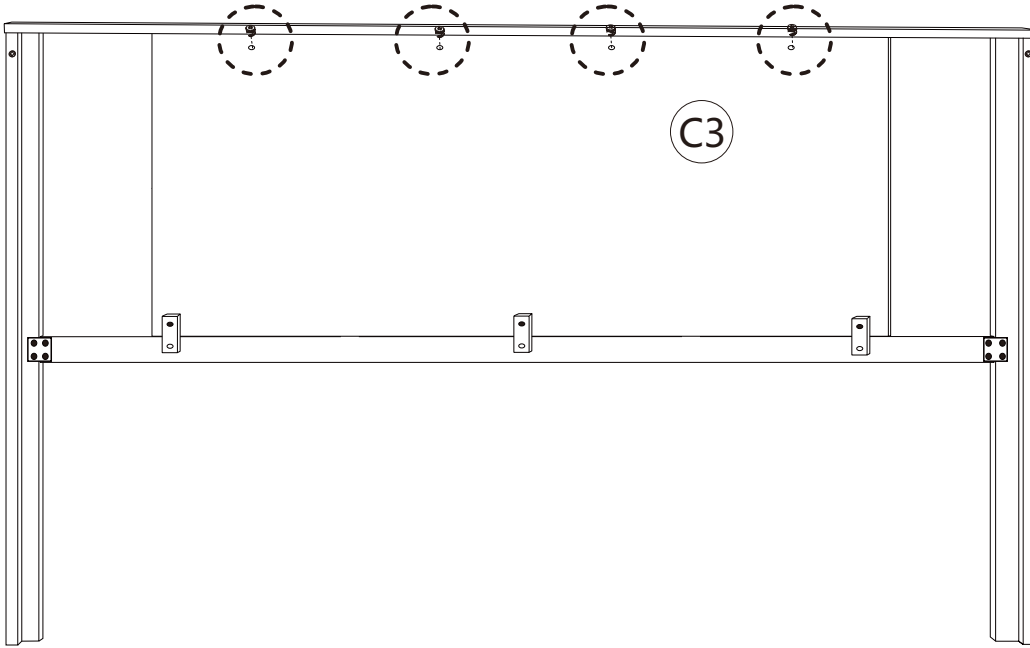
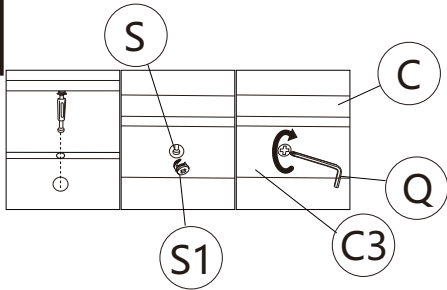

5



S1		4pcs
Q		1pc
M6		

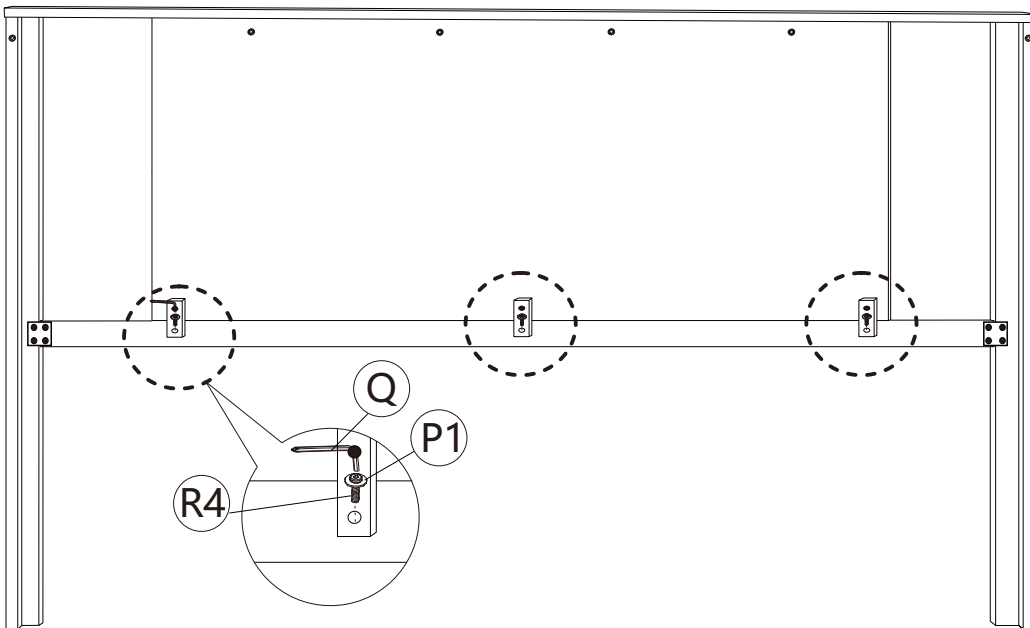

6



R4		3pcs
M6x25 mm		
P1		3pcs
φ6x18x1.5 mm		
Q		1pc
M6		

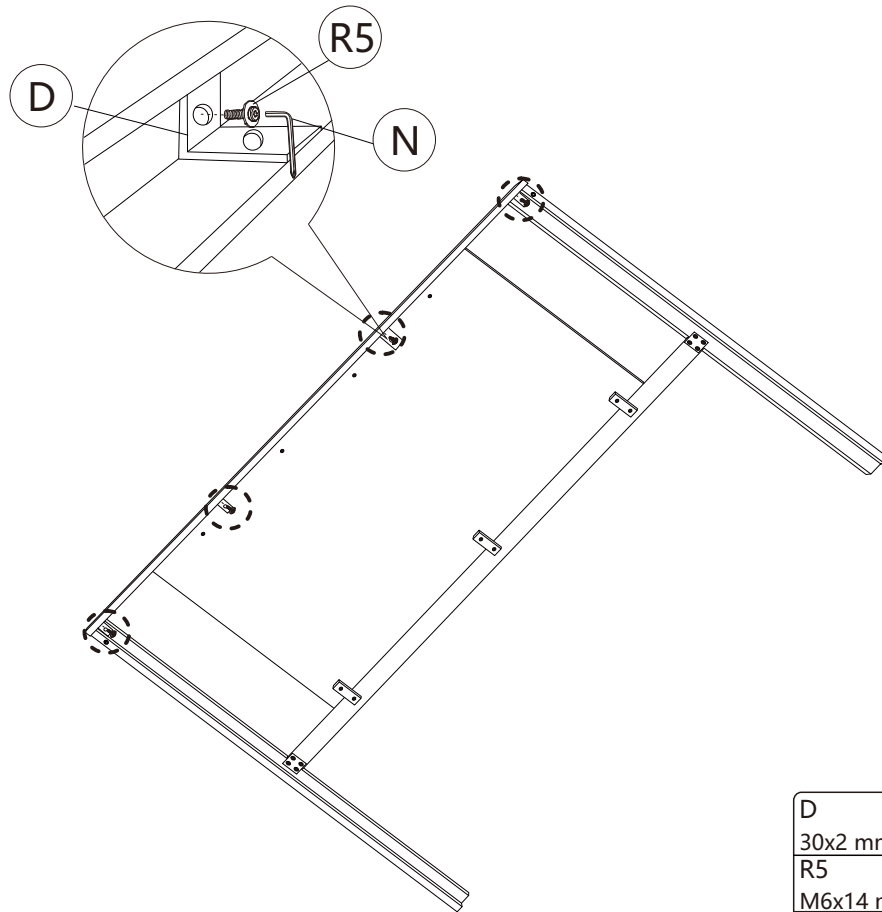

7

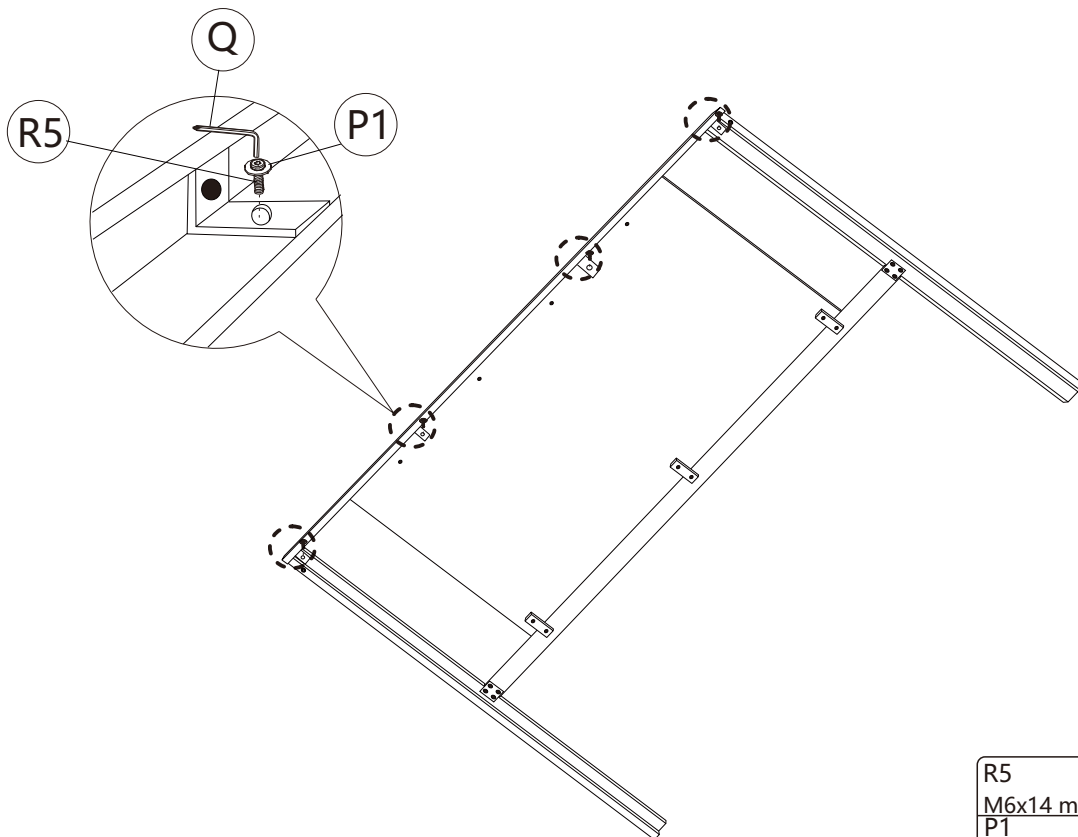

D		4pcs
R5		4pcs
Q		1pc
M6		

8



R5		4pcs
P1		4pcs
Q		1pc
M6		

9

Take out parts F1 and F3, and lock the iron frame foot L in the middle according to the figure. Note that there are **2 holes** located on the inner side of the board. Then lock the bed hanging piece X on the front and rear of the board, with **3 holes** on each side.

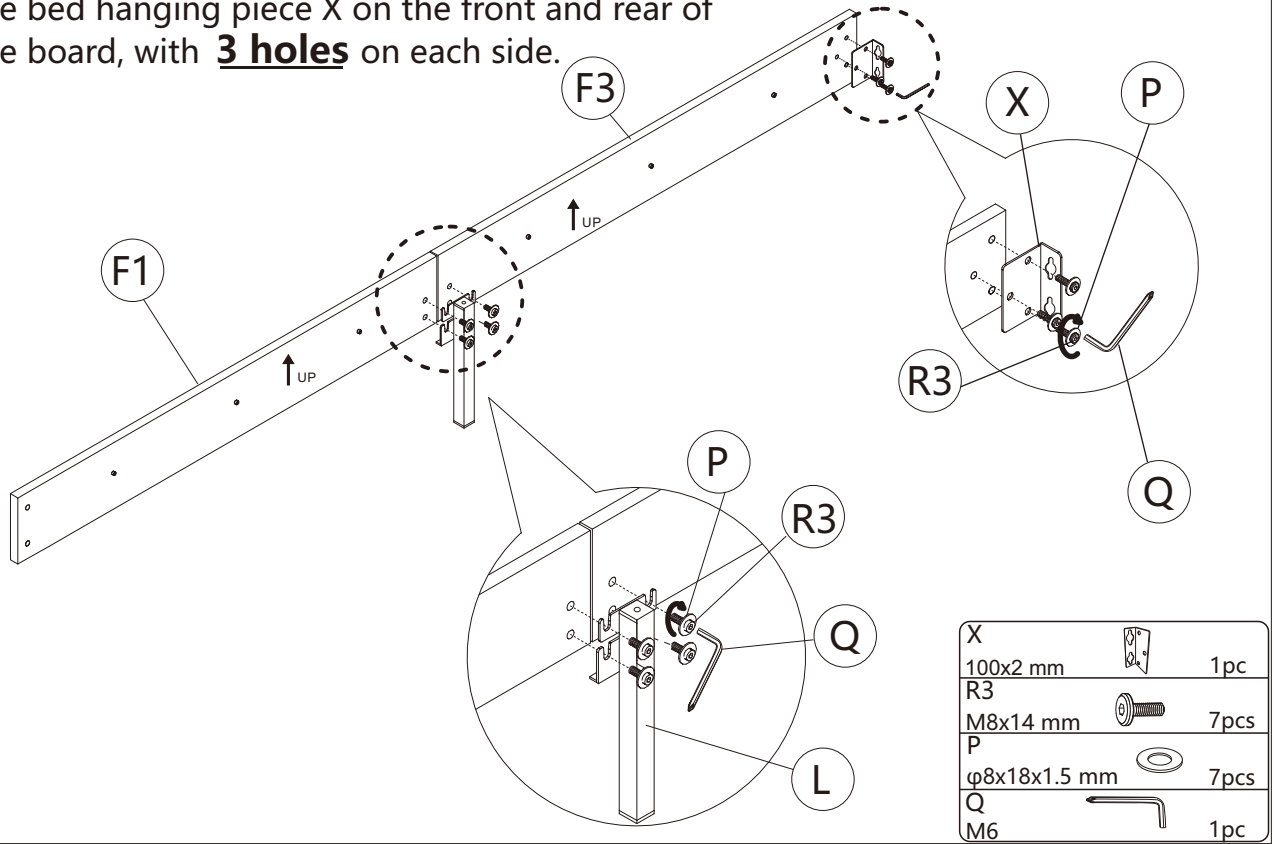

10

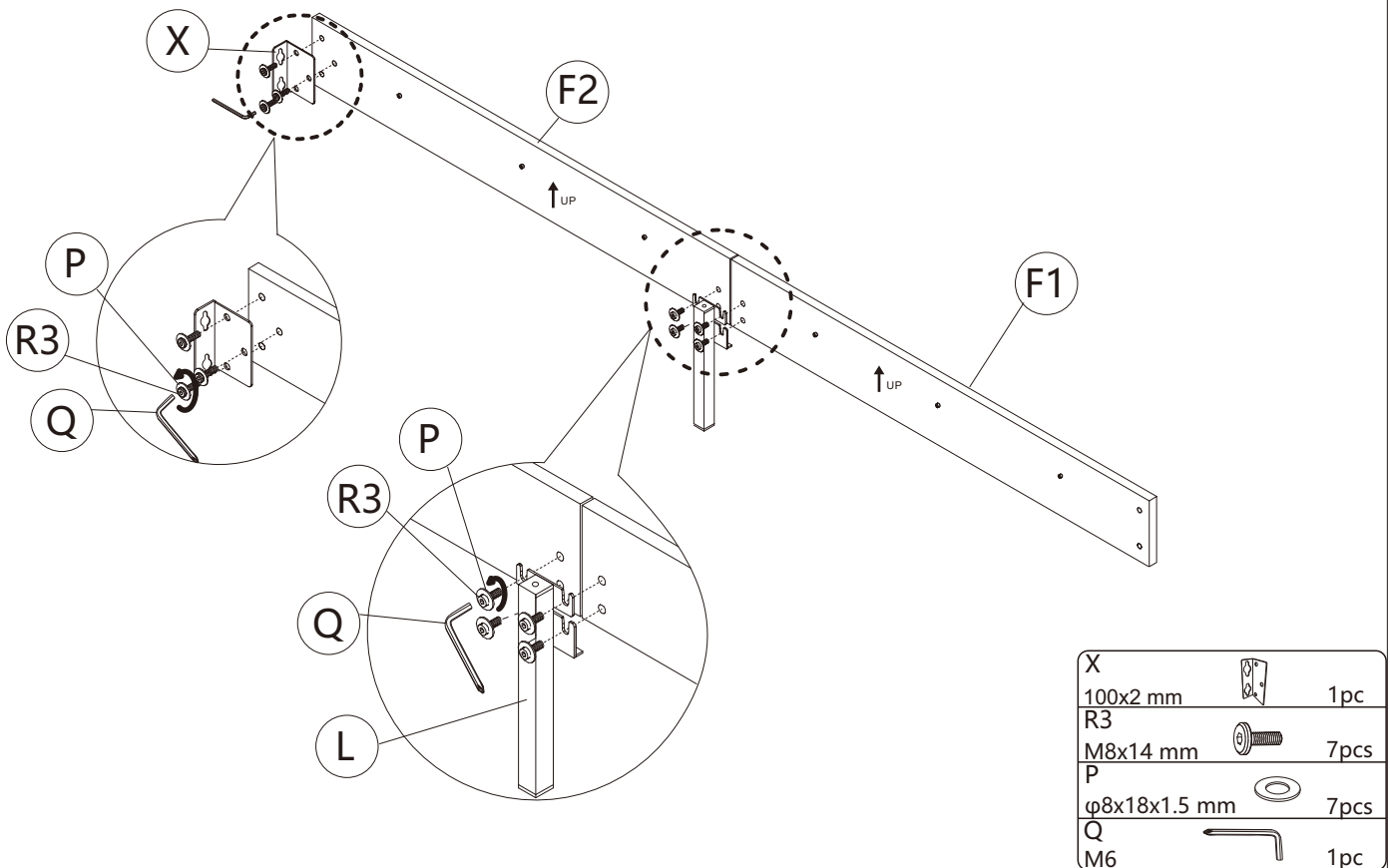

Same as Step 9.



ASSEMBLY INSTRUCTIONS

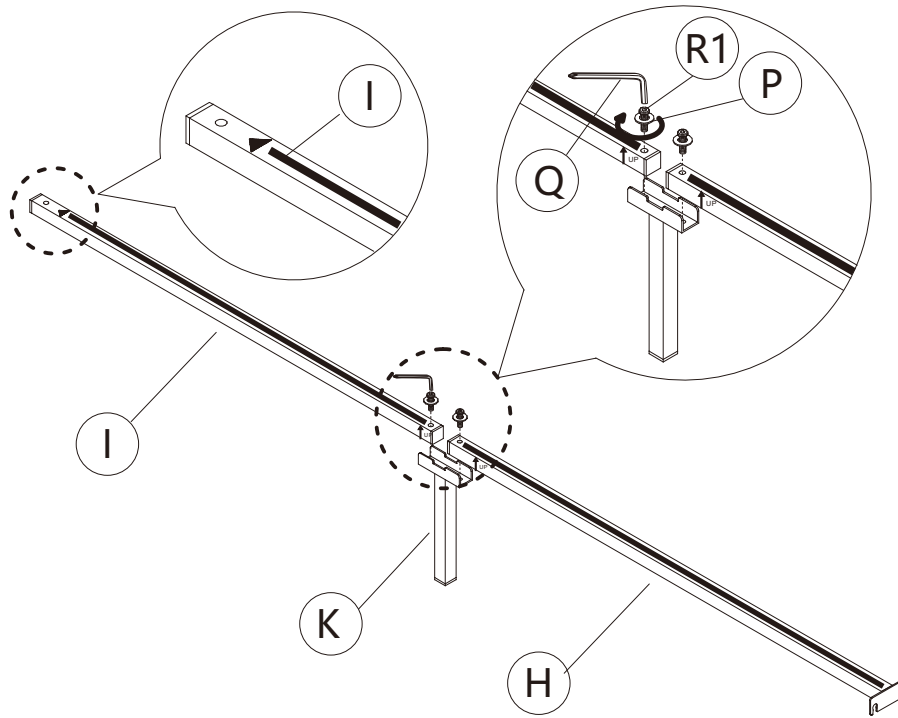

11

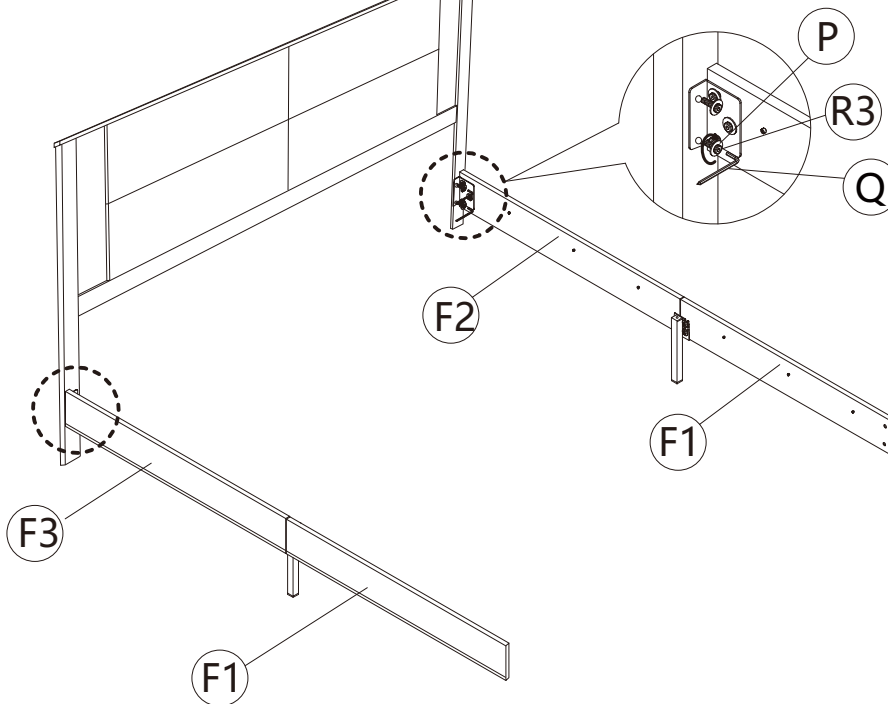

R1		2 pcs
M8x35 mm		
P		2 pcs
φ8x18x1.5 mm		
Q		1 pc
M6		

12



R3		4 pcs
M8x14 mm		
P		4 pcs
φ8x18x1.5 mm		
Q		1 pc
M6		

ASSEMBLY INSTRUCTIONS

13

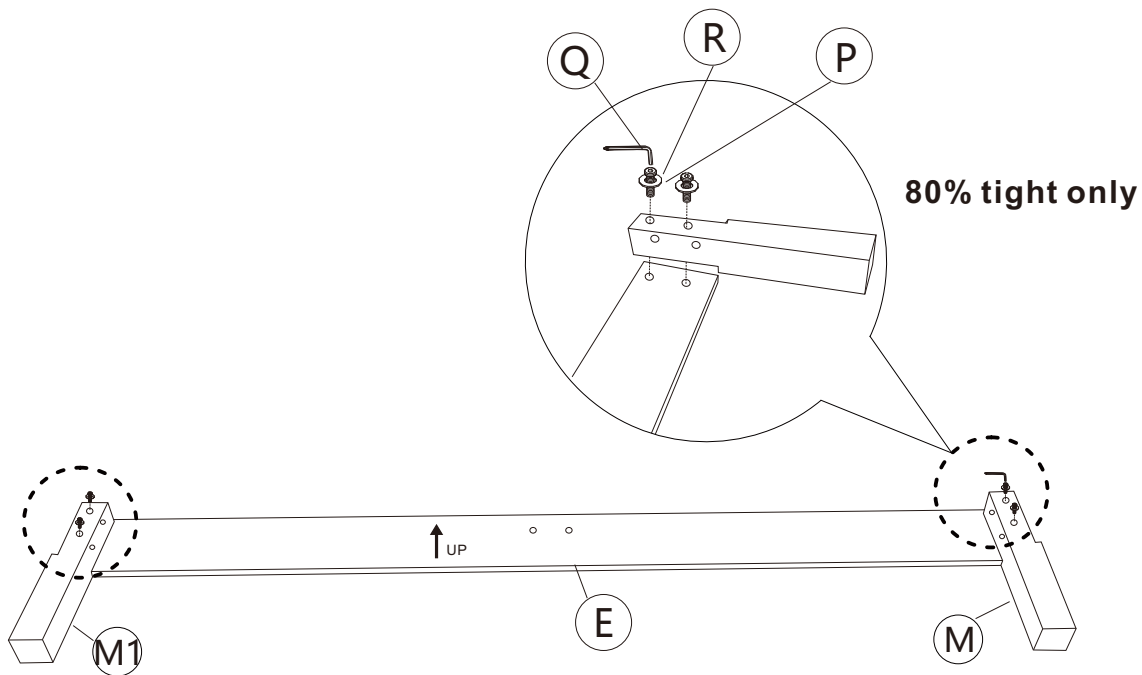

R		4pcs
M8x50 mm		
P		4pcs
ø8x18x1.5 mm		
Q		1pc
M6		

14

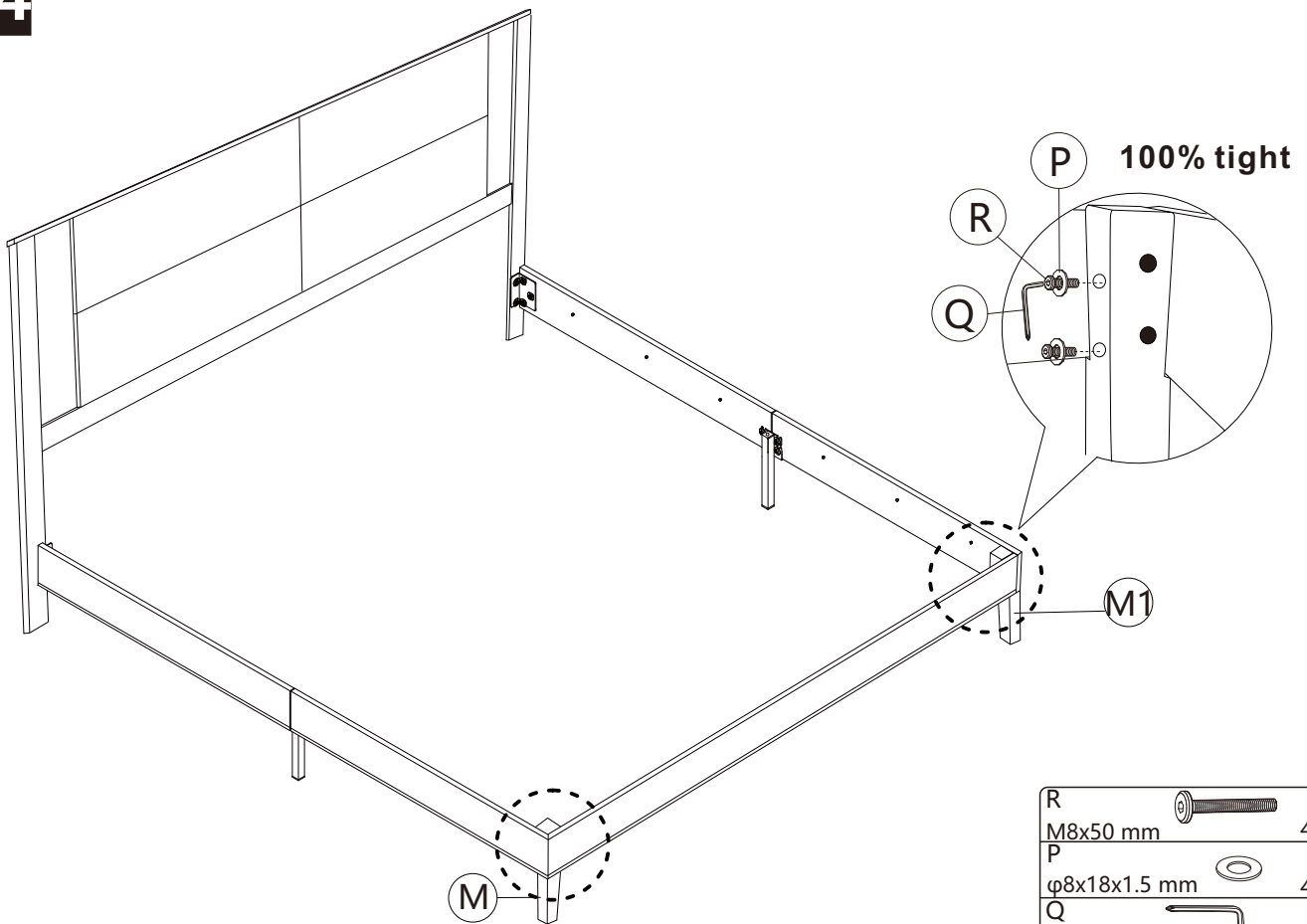



R		4pcs
M8x50 mm		
P		4pcs
ø8x18x1.5 mm		
Q		1pc
M6		

ASSEMBLY INSTRUCTIONS

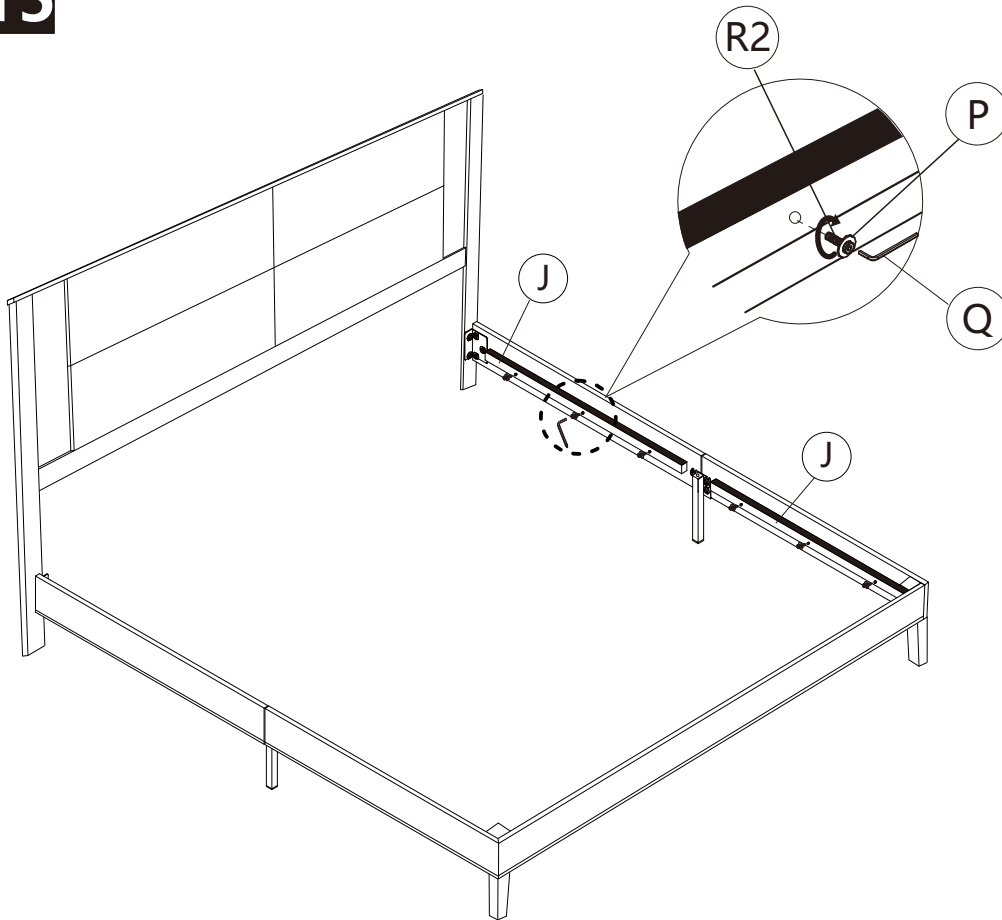

15

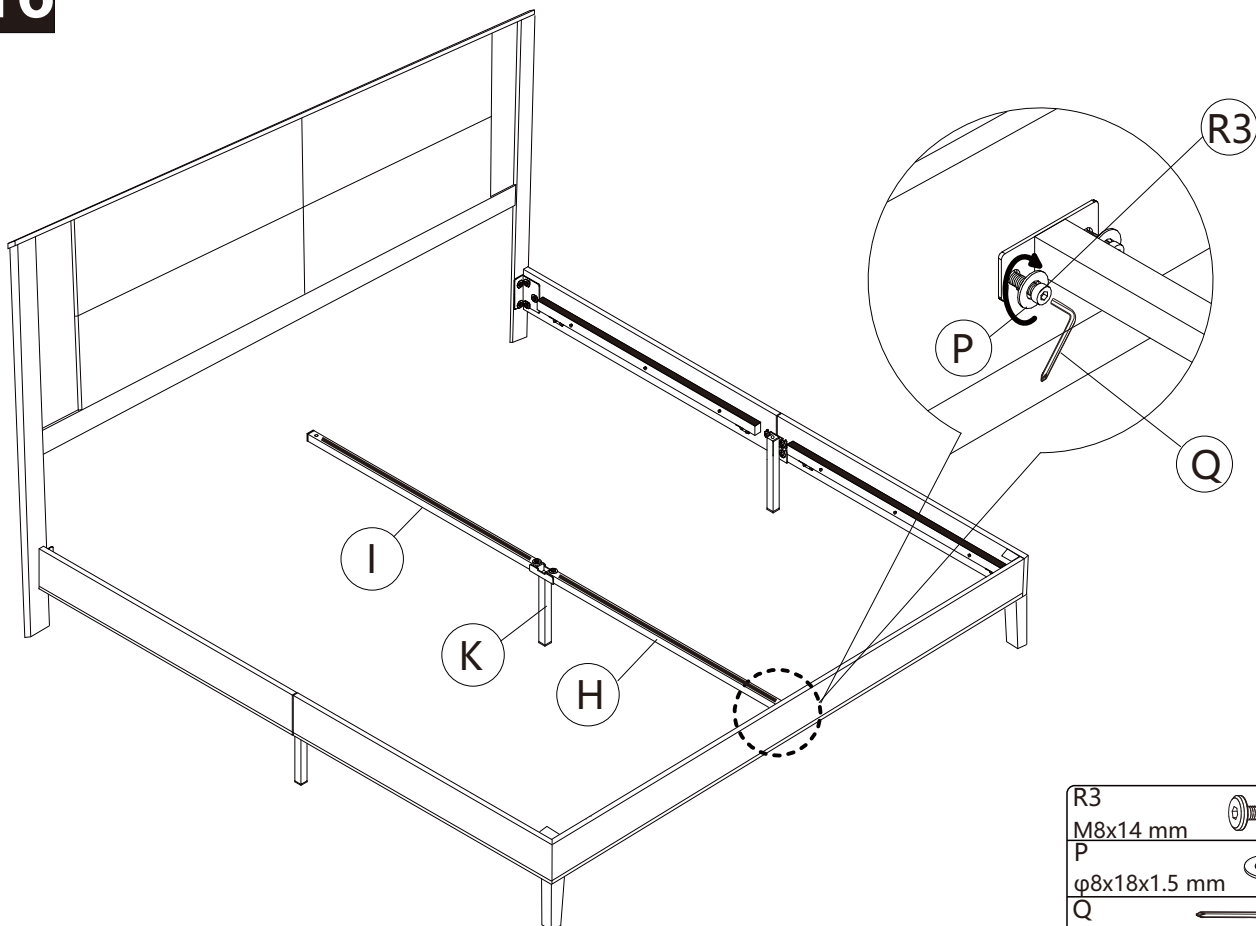

R2		12pcs
M8x30 mm		
P		12pcs
φ8x18x1.5 mm		
Q		1pc
M6		

16





R3		2pcs
M8x14 mm		
P		2pcs
φ8x18x1.5 mm		
Q		1pc
M6		

ASSEMBLY INSTRUCTIONS

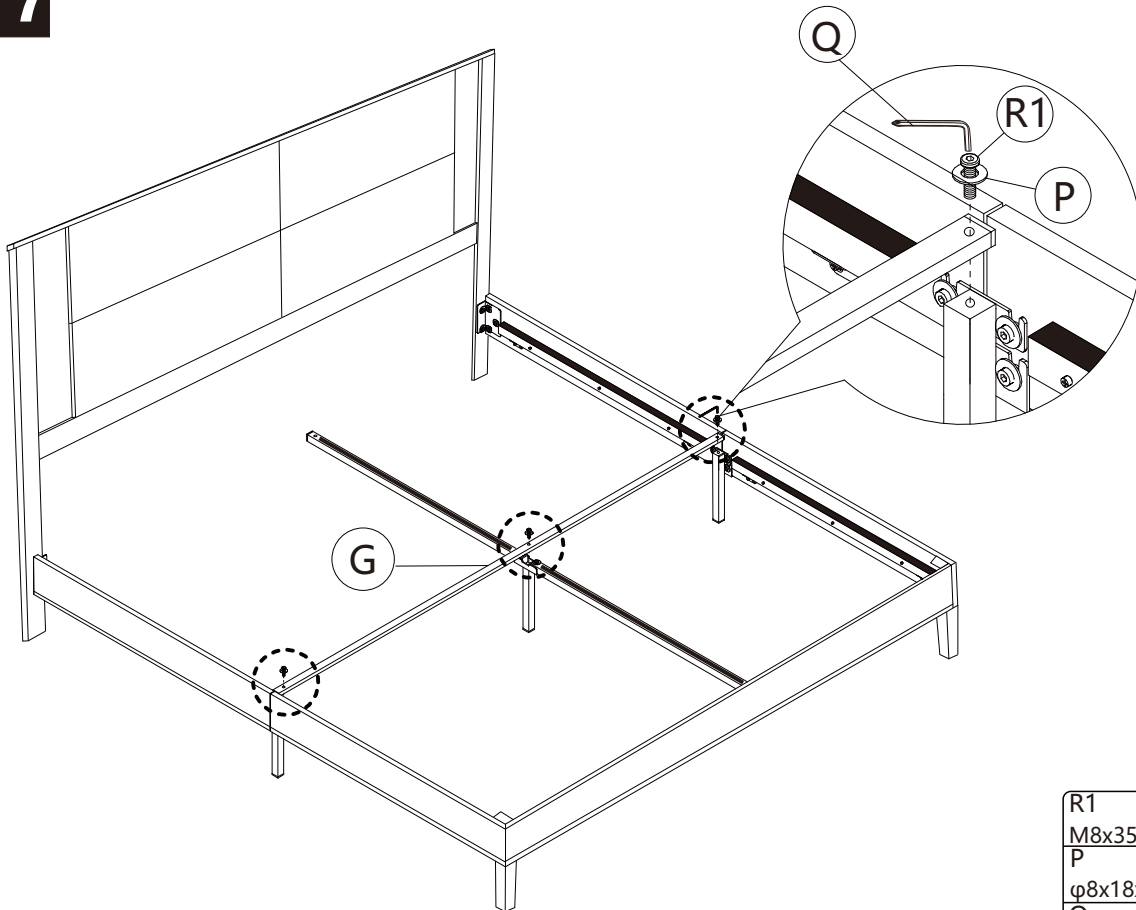
17





R1		3 pcs
M8x35 mm		
P		3 pcs
φ8x18x1.5 mm		
Q		1 pc
M6		

18

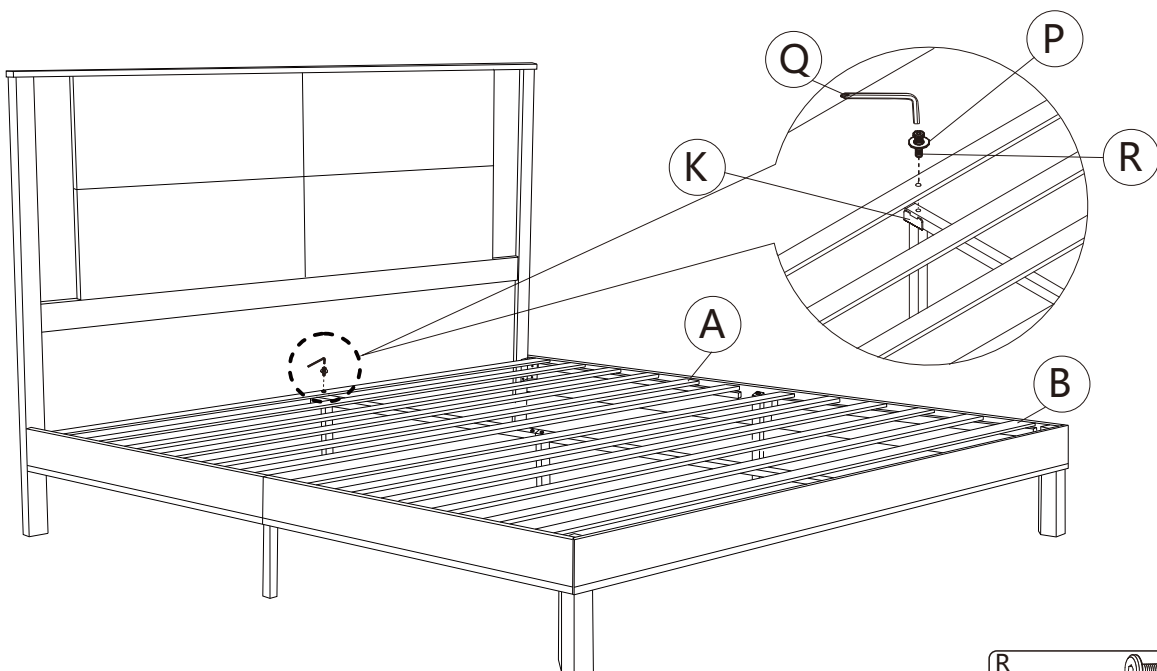
Note that there is a slat with a hole in part A for connecting to part K.



R		1 pc
M8x50 mm		
P		1 pc
φ8x18x1.5 mm		
Q		1 pc
M6		

Pls make sure that all screws are 100% tight.

19 Stick **○** on the back to avoid noise.

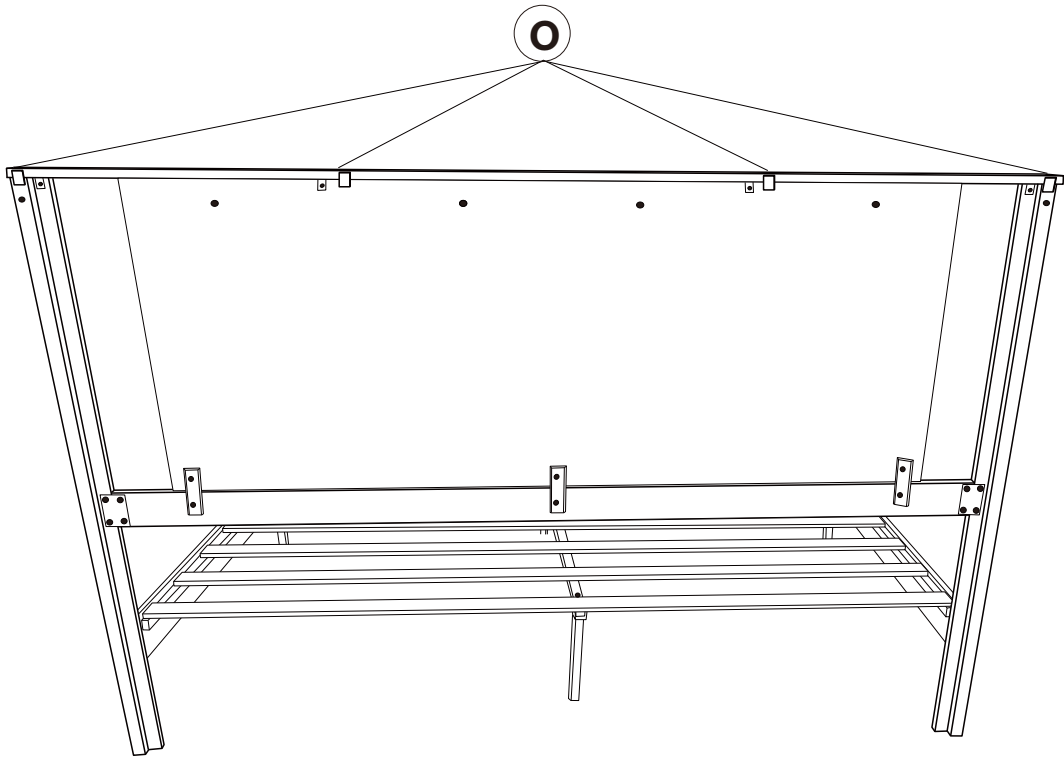

20

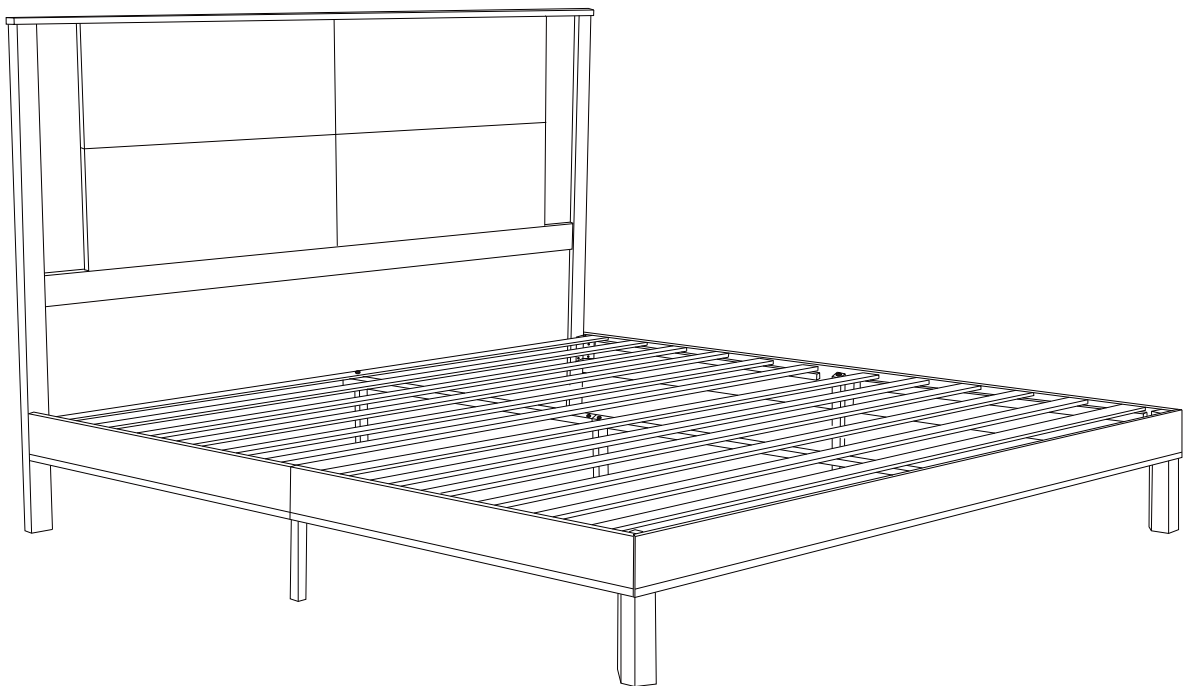

Installation Complete