

Installation & Assembly

Sideboard

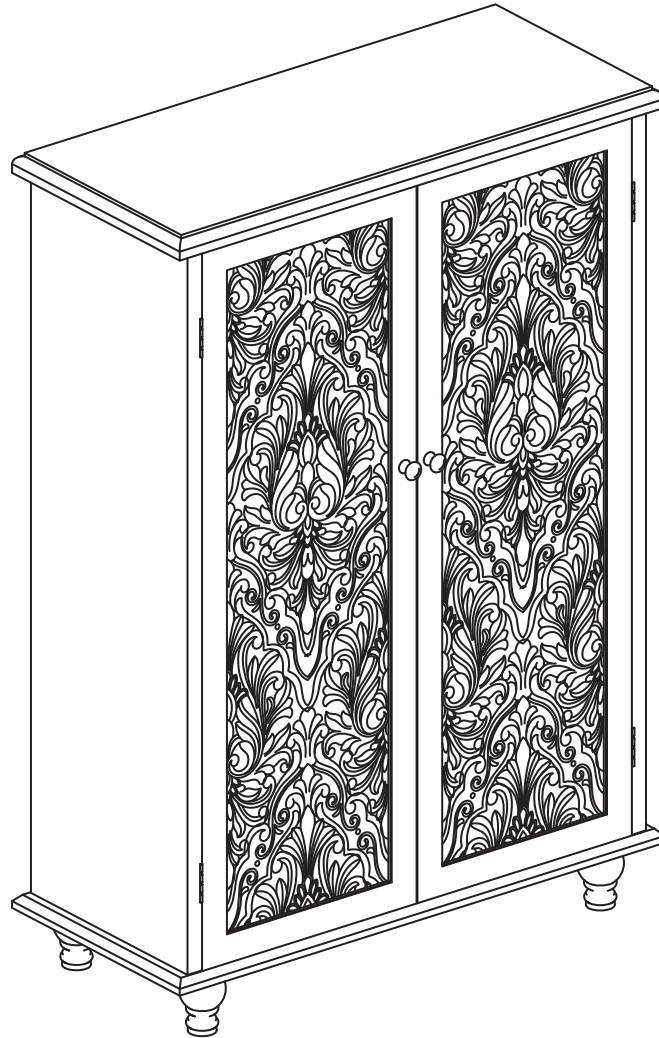

Please make sure to read the instruction manual carefully before installing the product.

Do Not Return This Product!

Contact our customer service team
for help first.

WARNING

- Unit can tip over causing severe injury or death.
- Anchor unit to stud in wall (if instructed to)
- Do Not allow children to climb on unit.
- put heavy items on lower shelves or drawers.

**PEOPLE NEEDED
FOR ASSEMBLY: 2**

CONTACT US!

Do NOT return this product!

Contact our friendly customer service team first for help.

- Open your item in the area you plan to keep it to avoid excessive heavy lifting.
- Identify, sort and count the parts before attempting assembly.
- Back panel must be used to make sure your unit is sturdy.
- Do NOT use harsh chemicals or abrasive cleaners on this item.
- Never push,pull,or drag your furniture.



BEFORE YOU START

- Read through each step carefully and follow the proper order
- Separate and count all your parts and hardware
- Give yourself enough room for the assembly process
- Have the following tools:Flat Head Screwdriver,#2 Phillips Head Screwdriver and Hammer
- Caution: IF using a power drill or power screwdriver for screwing,please be aware to slow down and stop when screw is tight.Failure to do so may result in stripping the screw.



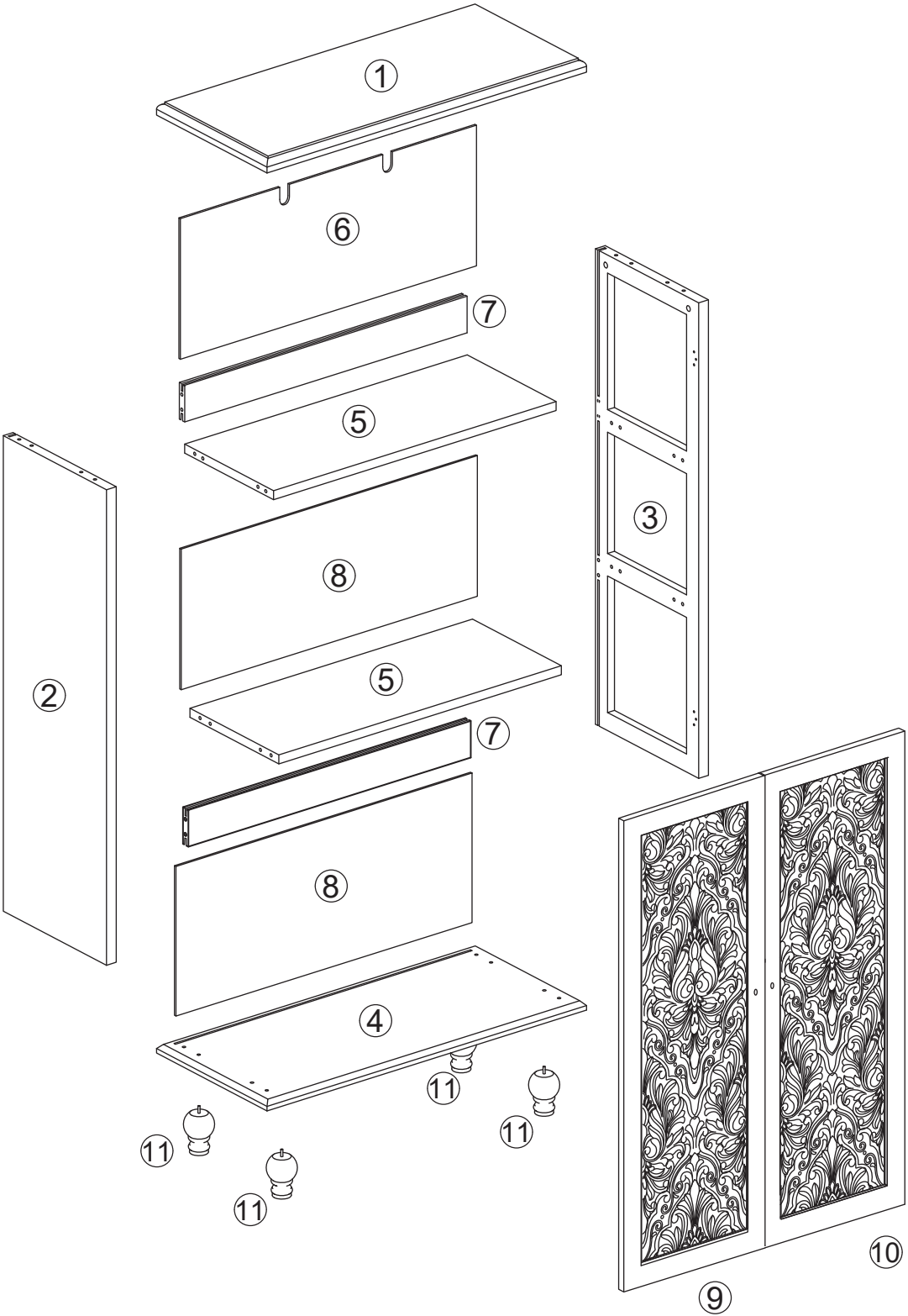



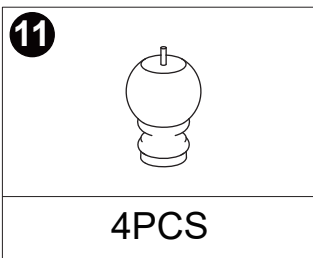
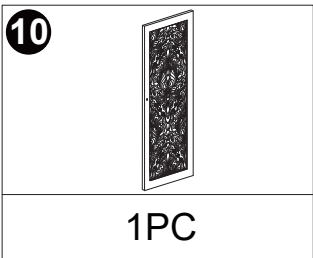
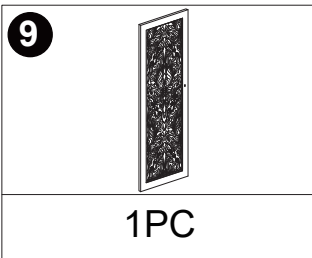
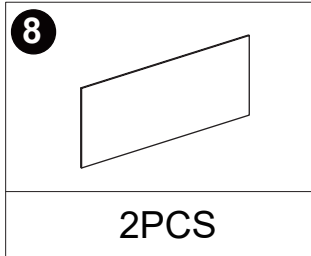
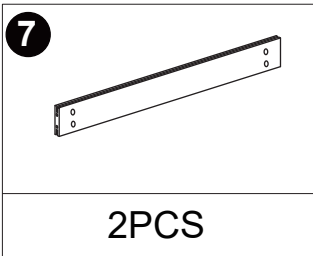
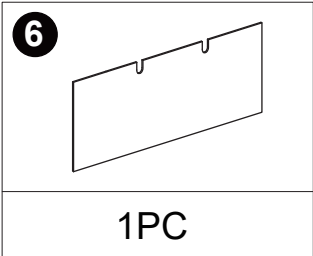
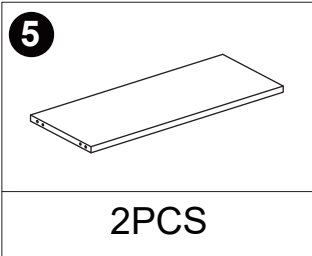
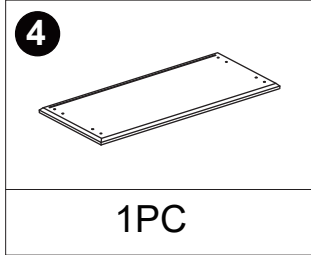
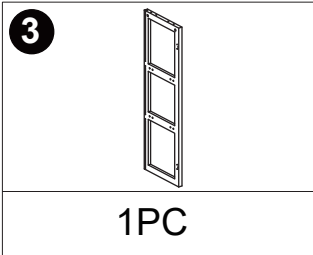
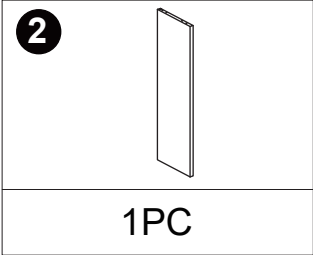
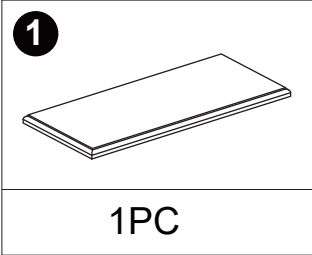



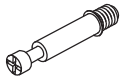



BOARD IDENTIFICATION



BOARD IDENTIFICATION



THE HARDWARE

A x20  Cam Bolt	B x20  Cam Lock	C x16  Wood Dowel Ø8x30mm	D x6  Screw Ø4x35mm	E x42  Screw Ø3x16mm
F x12  Wedge	G x2  Wall Anchor	H x2  Safety bracket kit	I x2  Screw Ø4x12mm	J x4  Hinge
K x2  Bolt and Handle Ø4x22mm	L x4  Foot pad	M x2  Magnetic Catch	N x2  Metal Plate	

IMPORTANT :

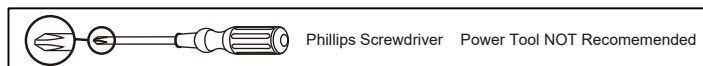

1. Do not tighten bolts / screws completely until all bolts / screws are lined up and inserted into holes.
2. Do not over tighten screws and bolts to avoid stripping.
3. Please use hand tools to assemble this product. Do not use power tools.

CAM LOCK FASTENING SYSTEM

This Cam Lock Fastening System will be used throughout the assembly process.

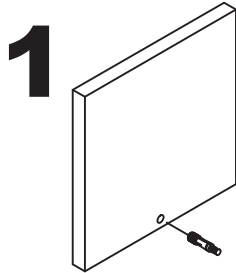

1
Press CAM BOLT into hole.

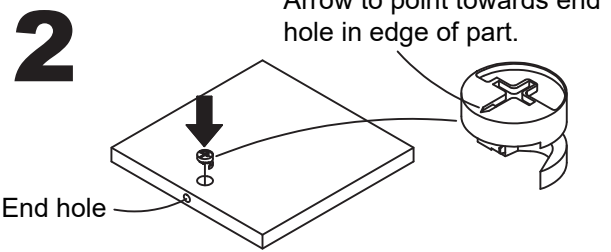

2
Press CAM LOCK into hole.

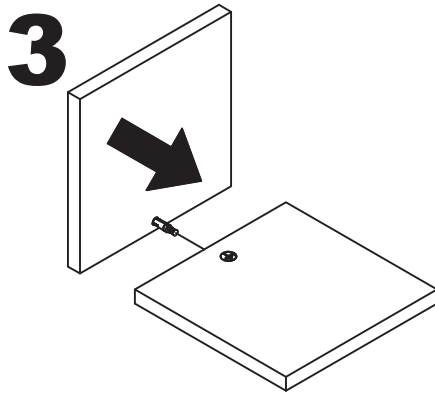

3
Press parts together so CAM BOLT inserts into edge hole.

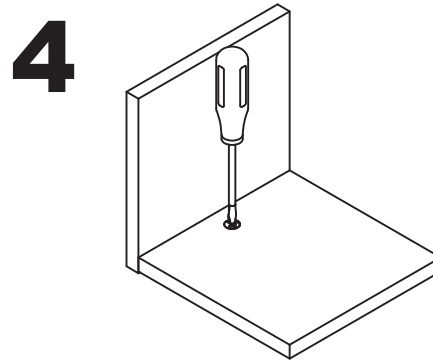

4
Using a screwdriver, turn the CAM LOCK clockwise to lock the CAM LOCK and CAM BOLT into their holes and fastening parts together.

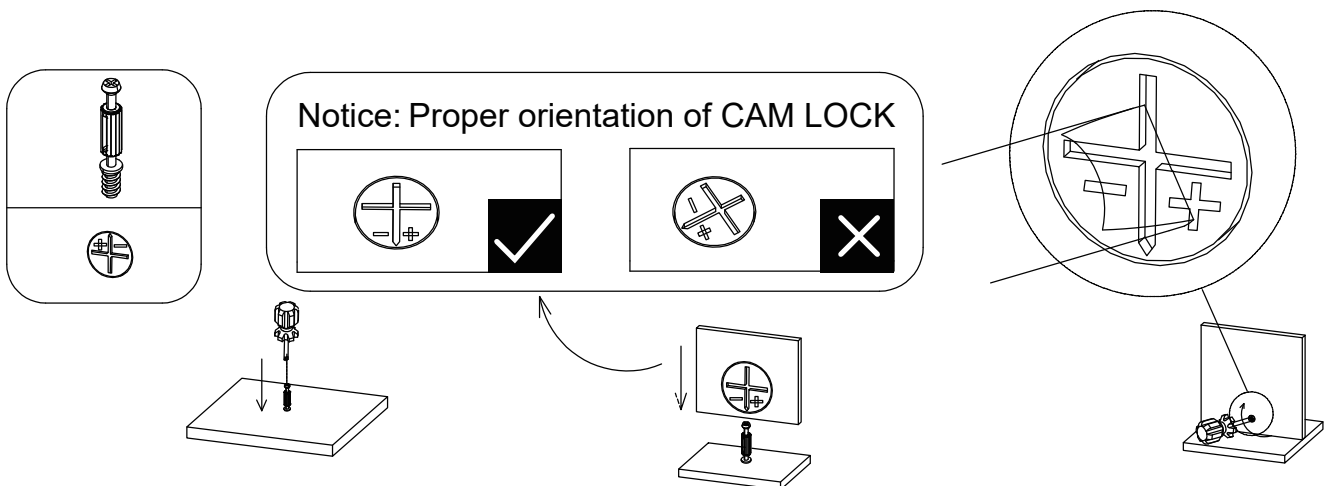

INSTALLATION STEPS

STEP 1

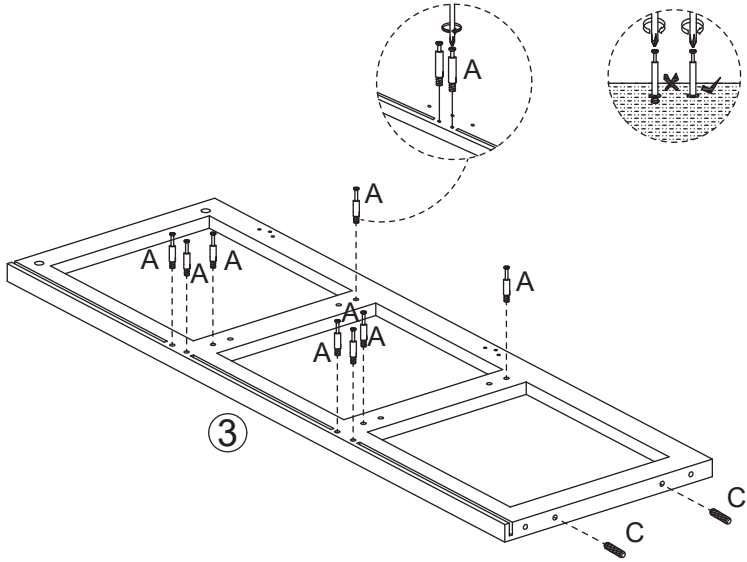
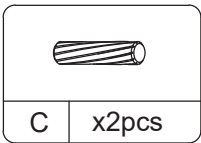
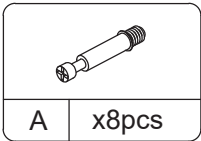

STEP 2

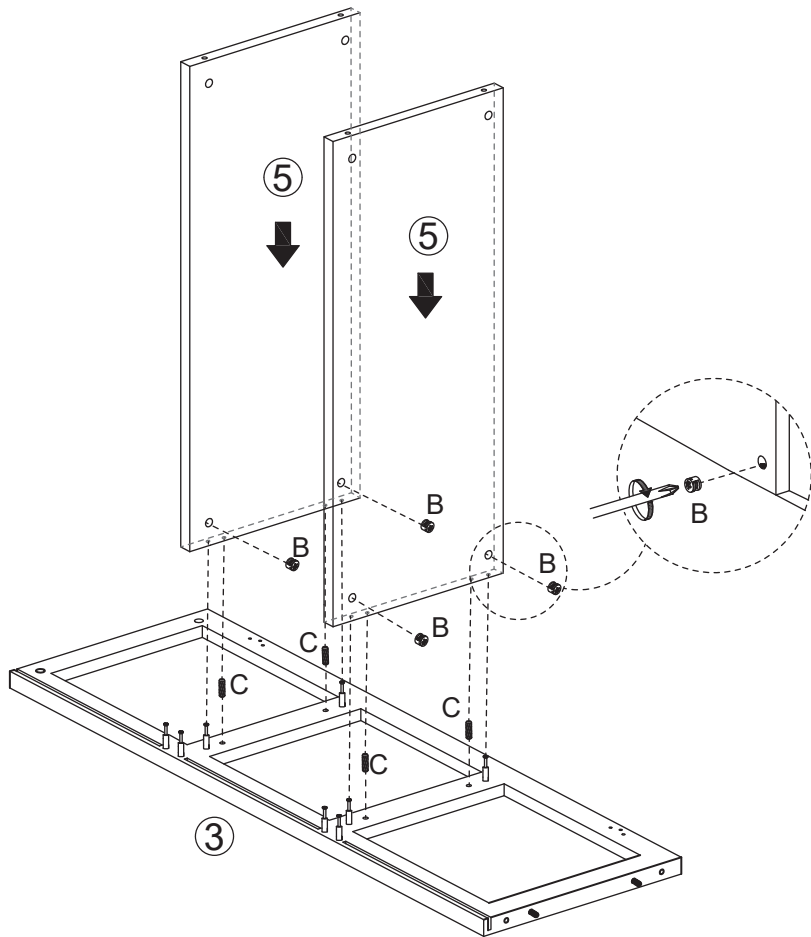
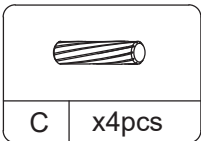
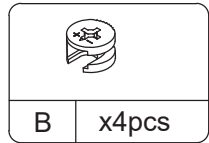

INSTALLATION STEPS

STEP 3

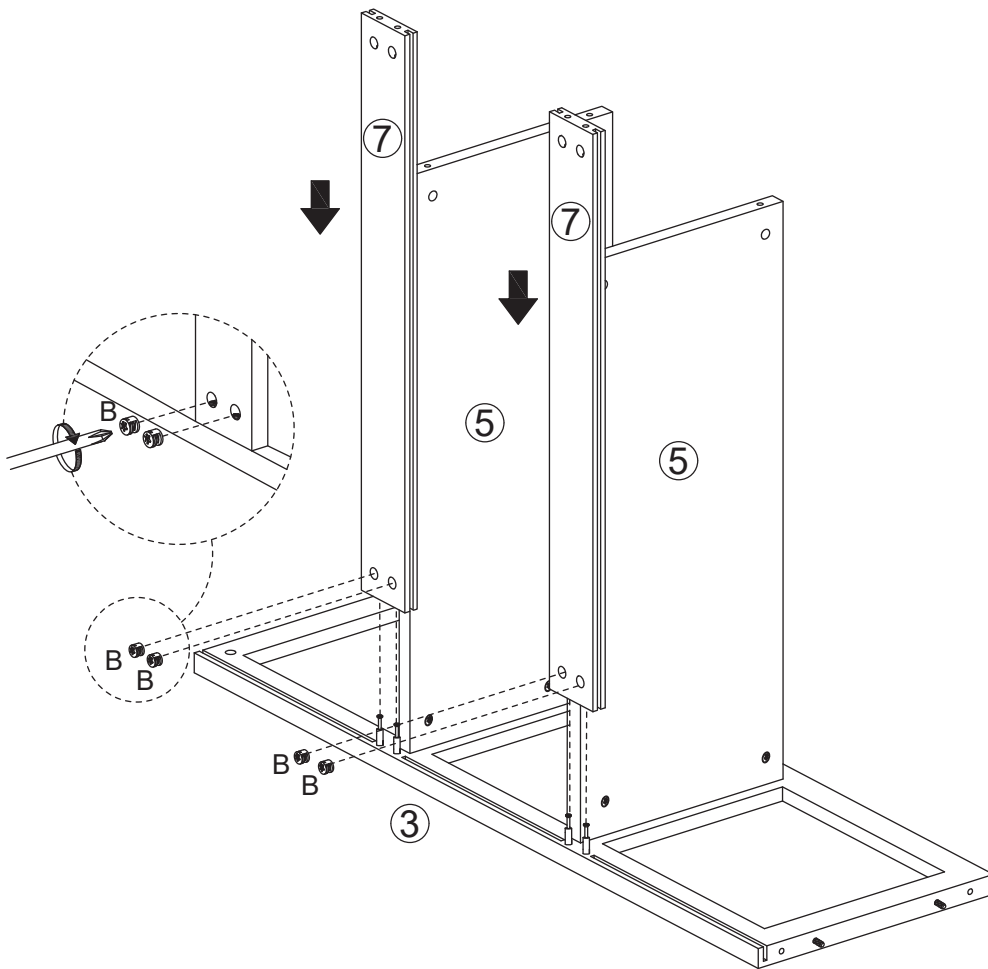

INSTALLATION STEPS

STEP 4

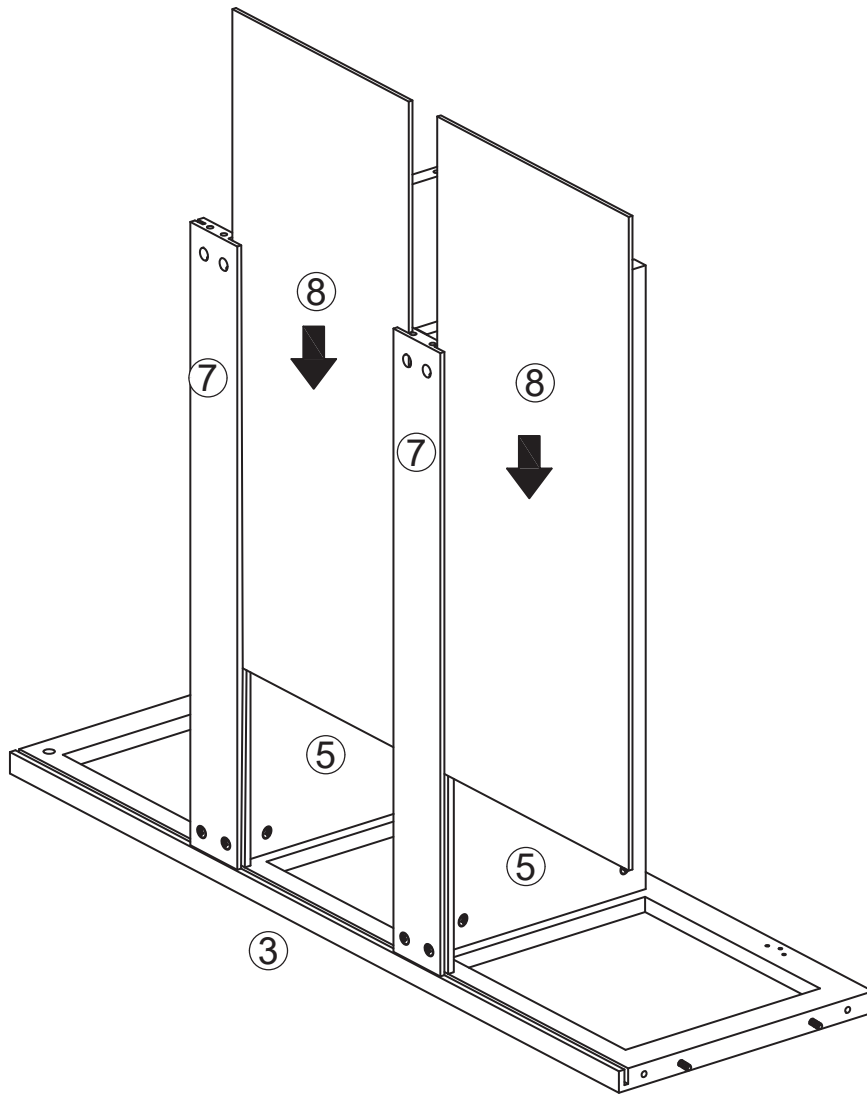

INSTALLATION STEPS

STEP 5

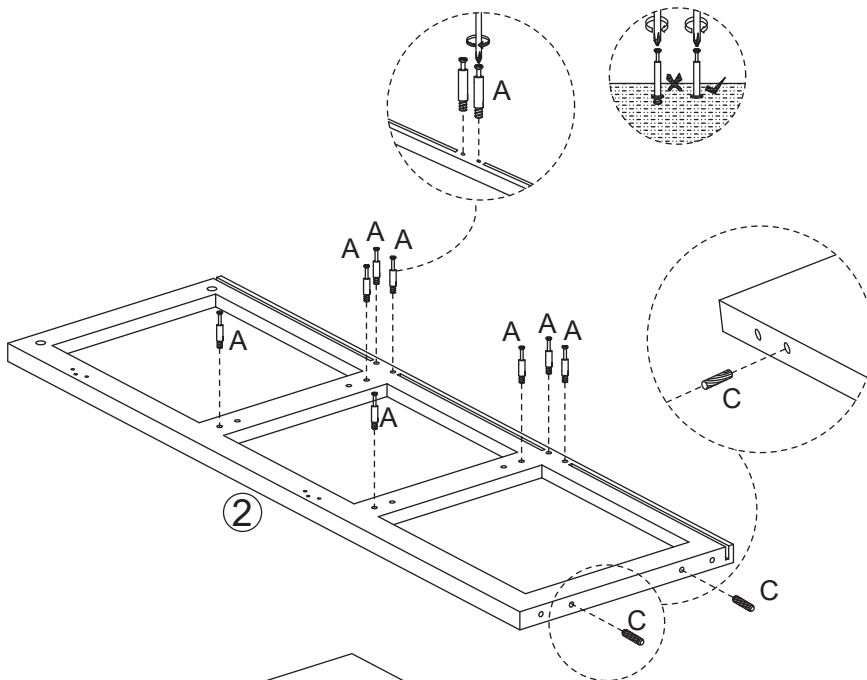
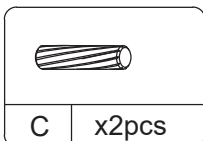
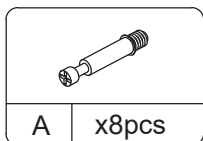

STEP 6

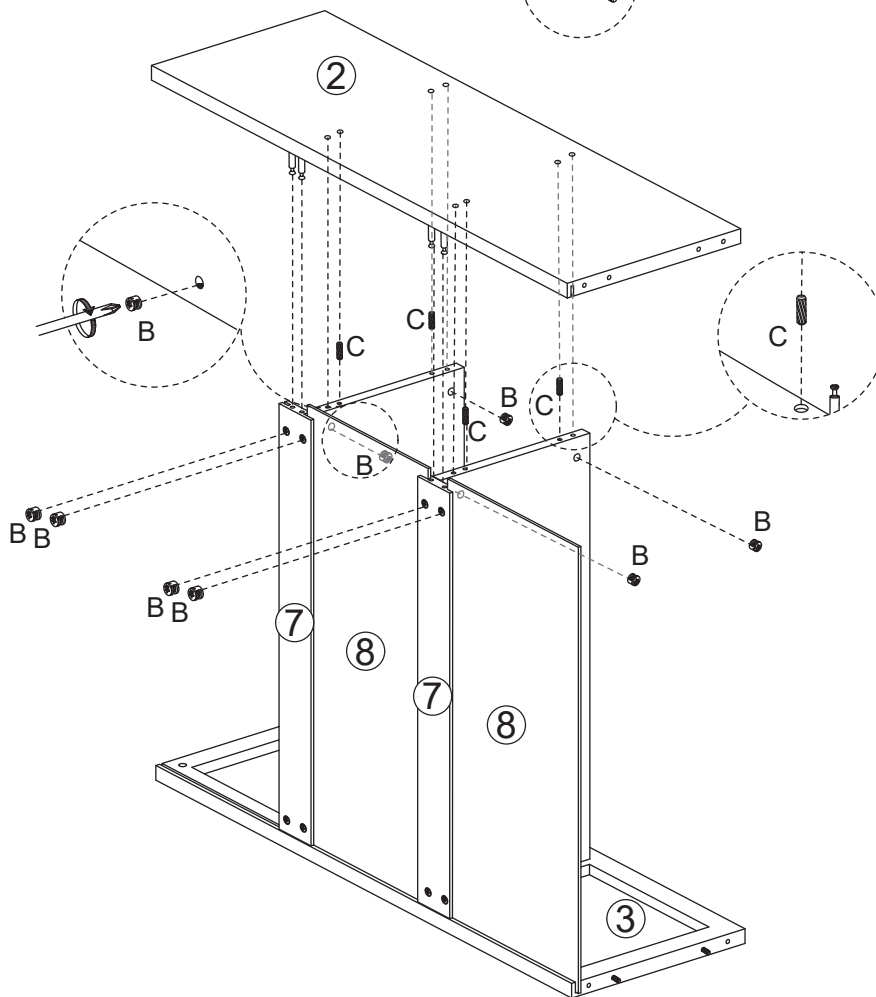
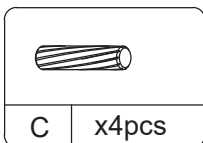
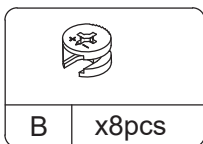

INSTALLATION STEPS



STEP 7

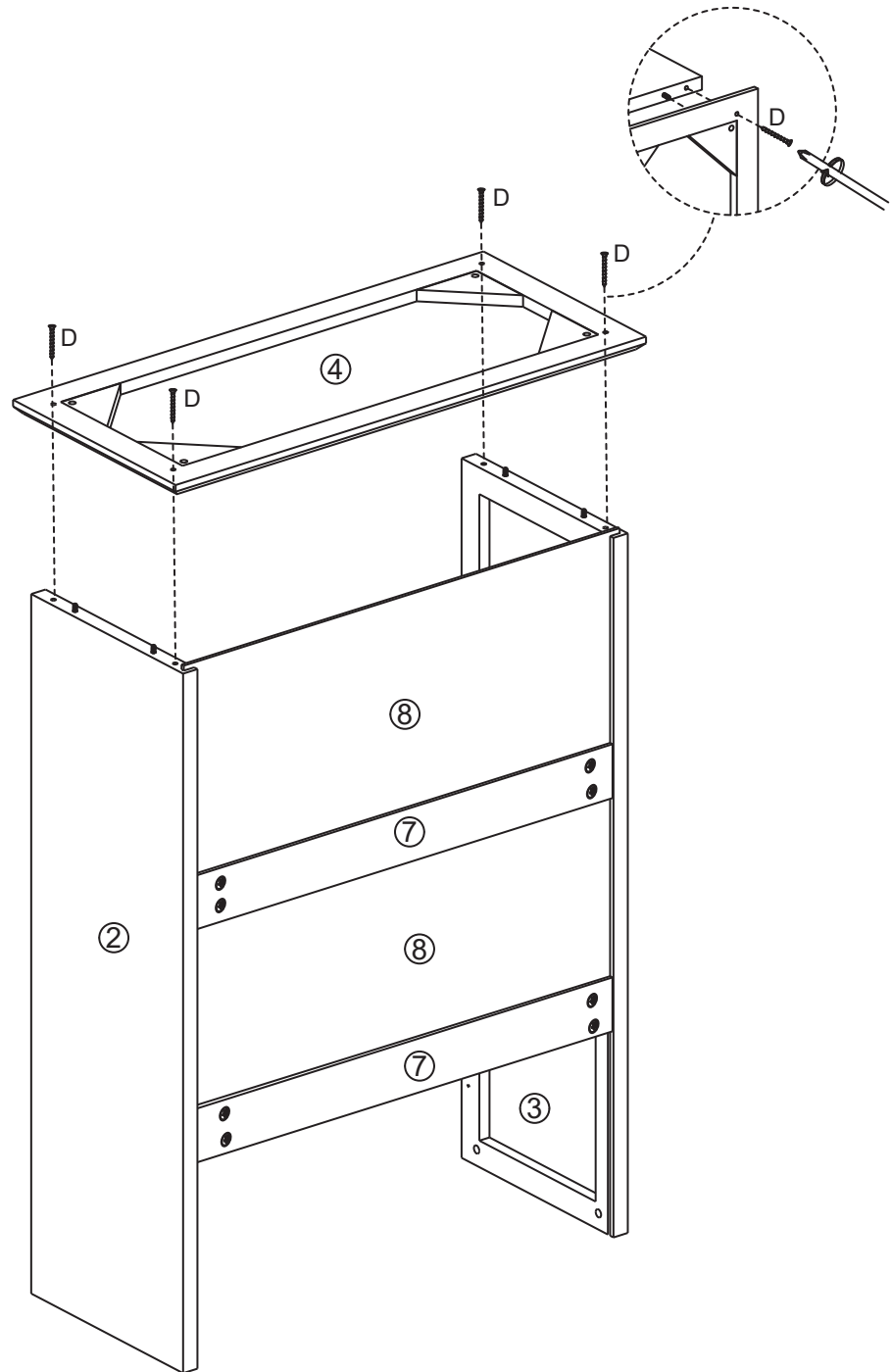
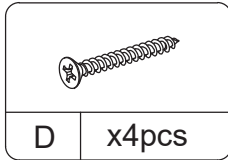

INSTALLATION STEPS



STEP 8

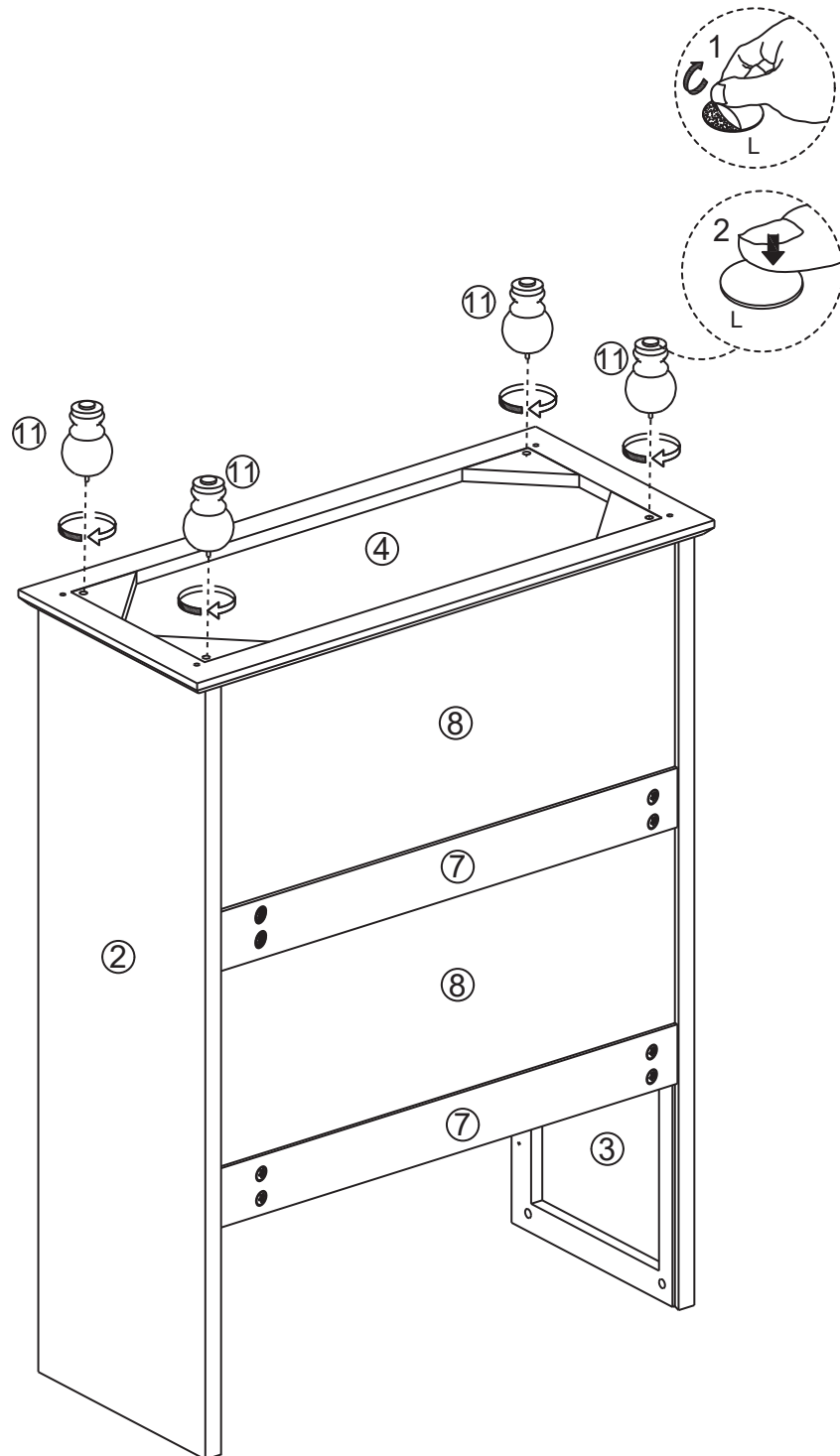
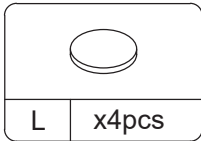

INSTALLATION STEPS

STEP 9

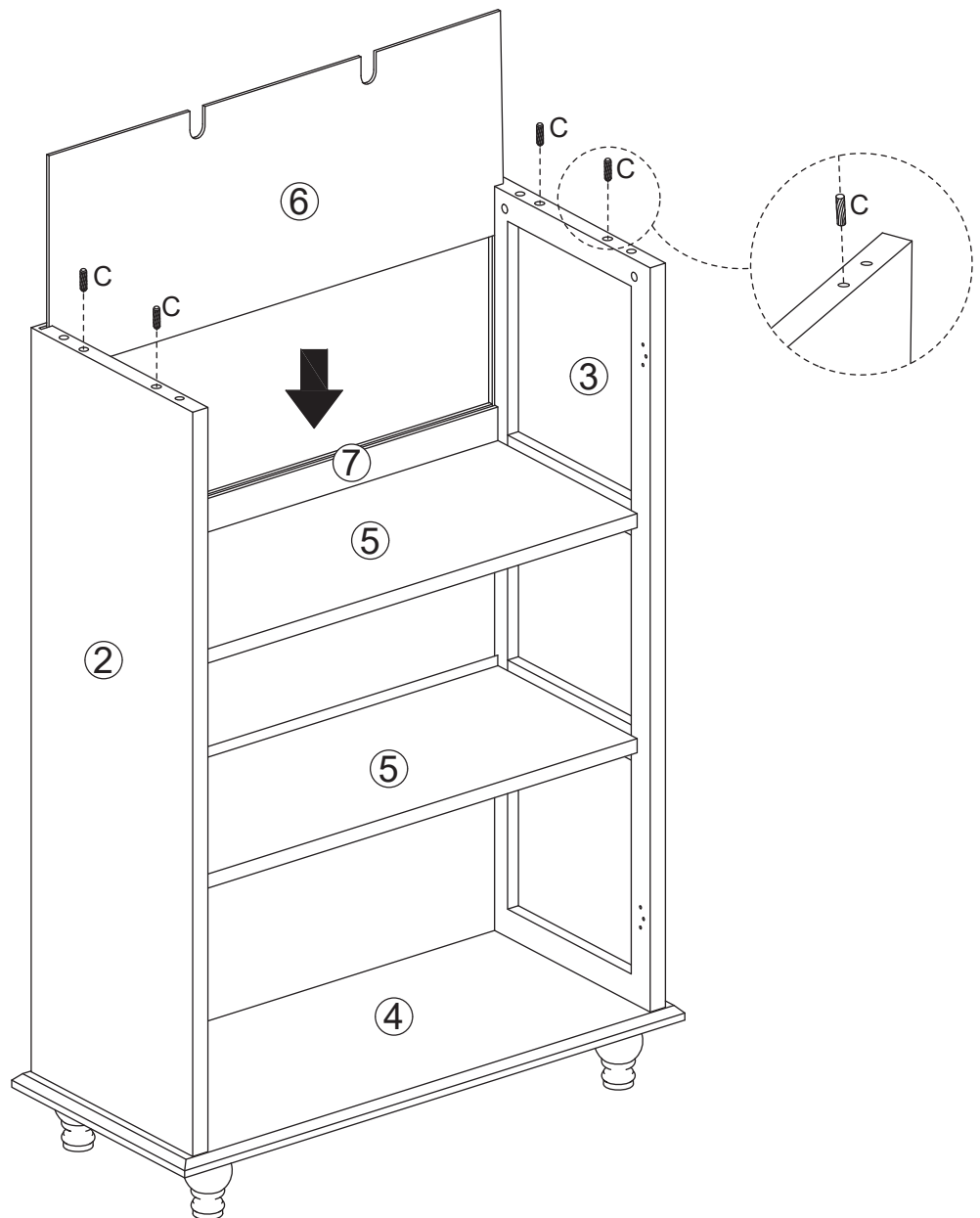
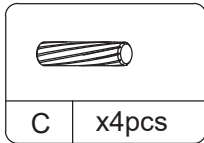

INSTALLATION STEPS

STEP 10

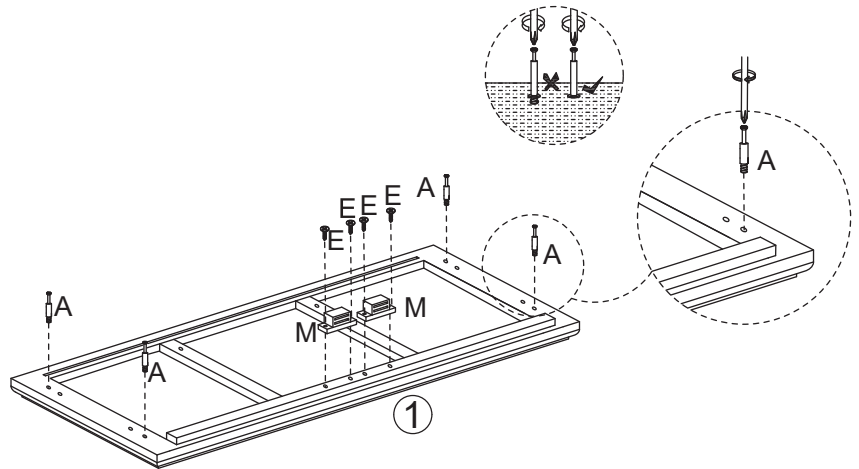
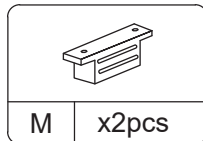
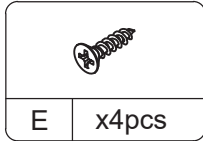
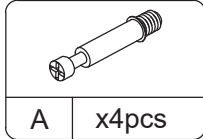

STEP 11

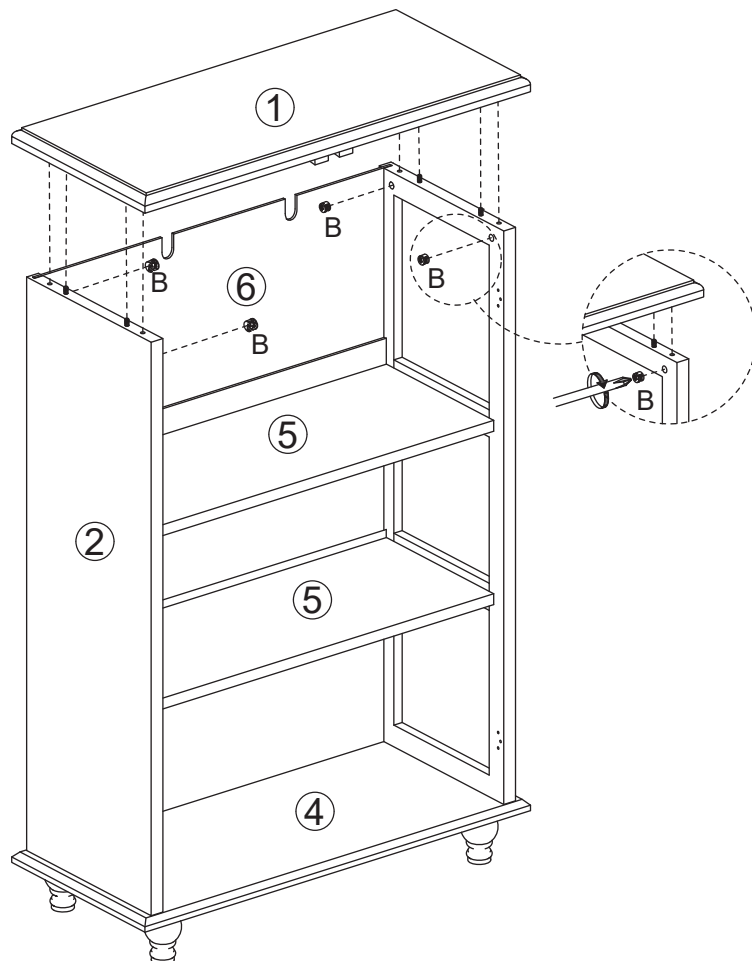
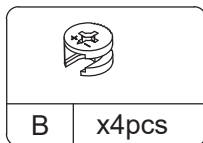

INSTALLATION STEPS



STEP 12

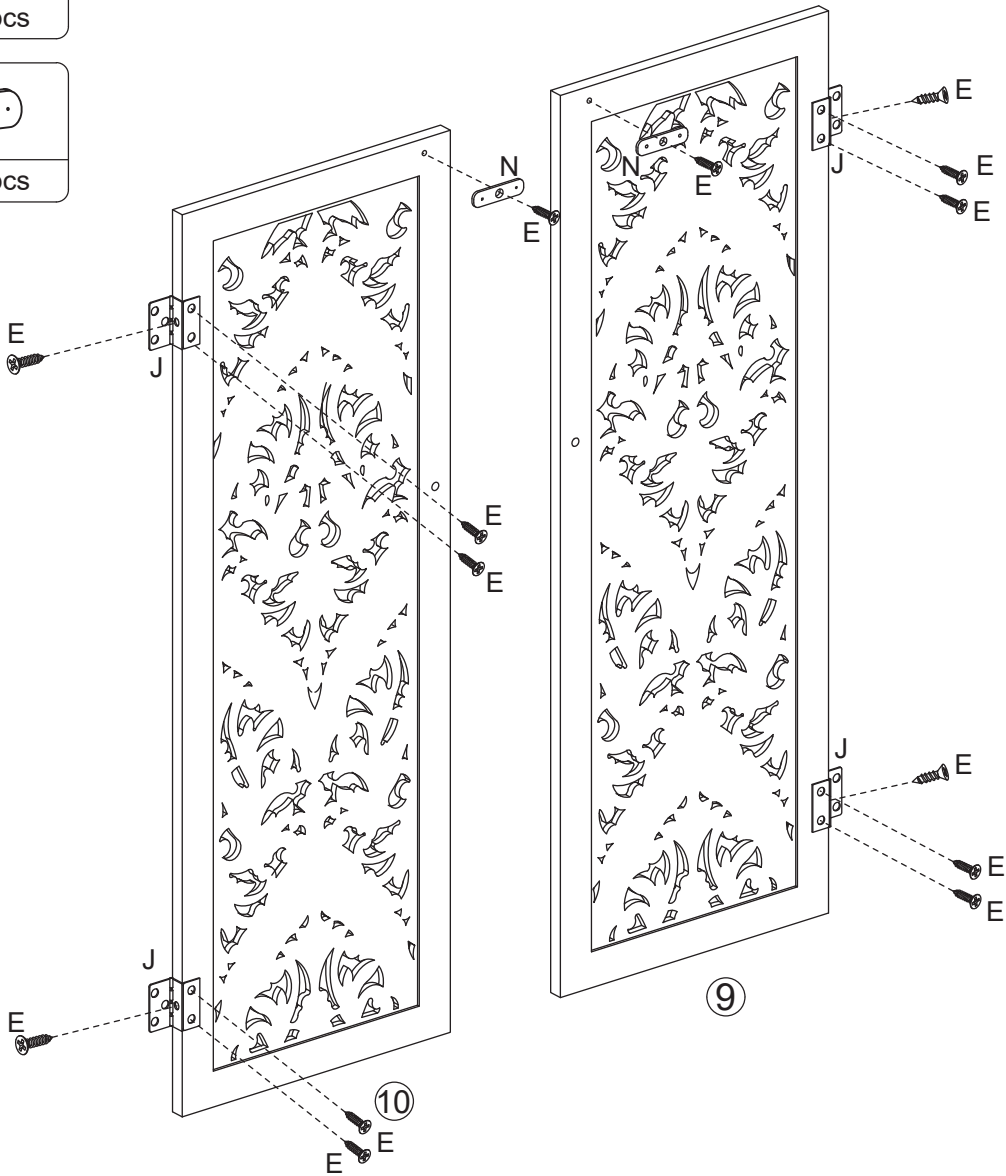
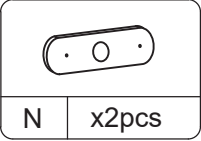
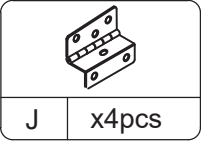
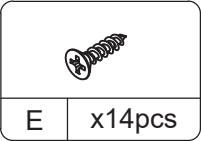

INSTALLATION STEPS

STEP 13

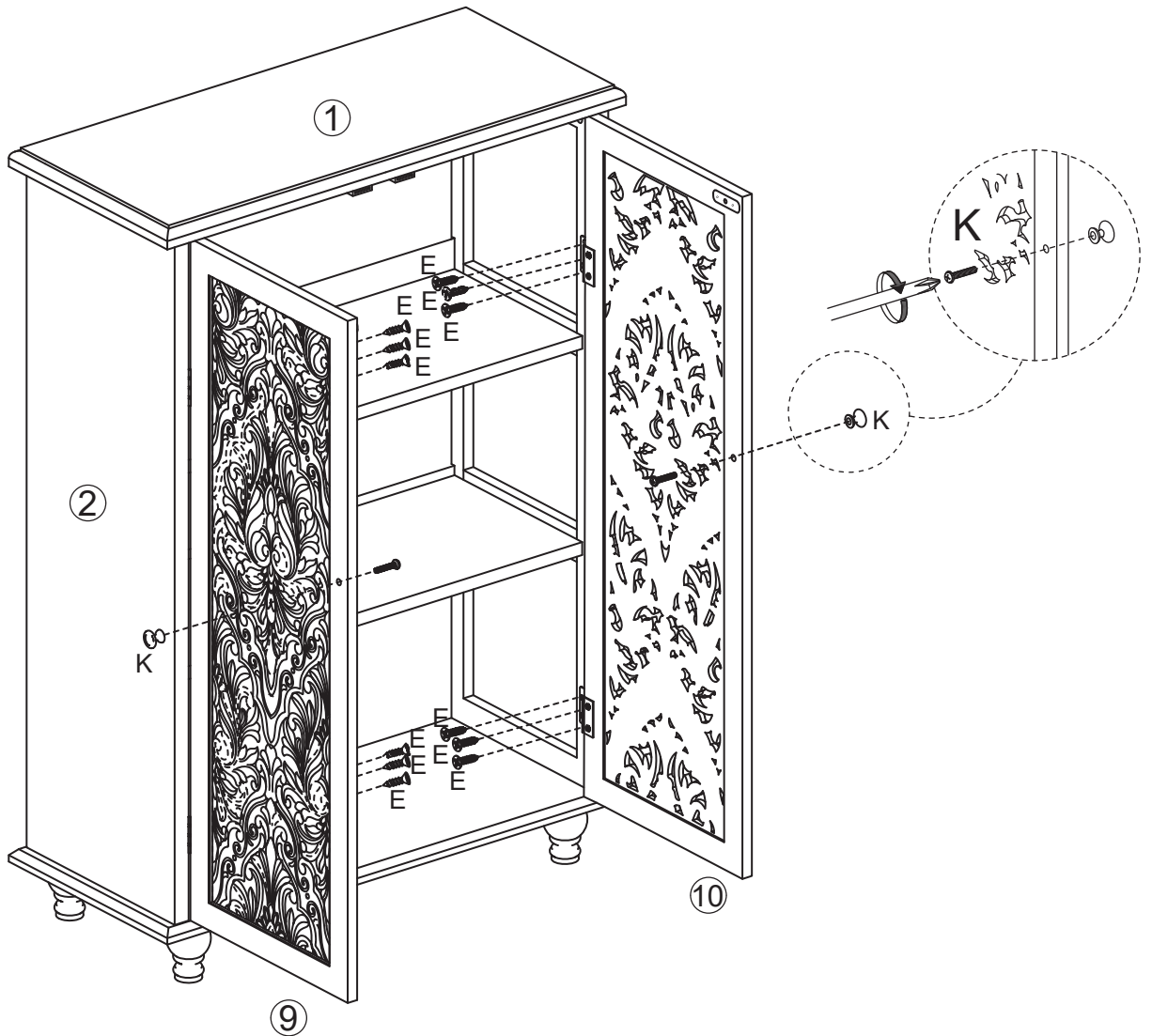
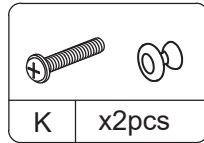
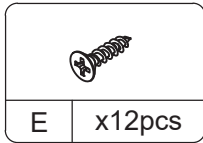

INSTALLATION STEPS

STEP 14

