

www.FlowWall.com

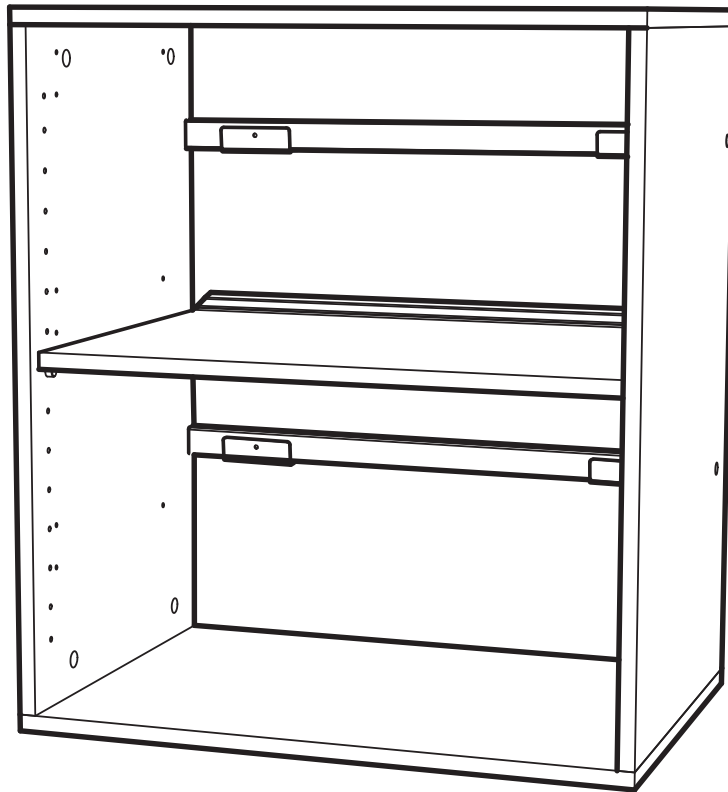

model number:

FWC-C03-G

Base Cabinet Body





Distributed by:

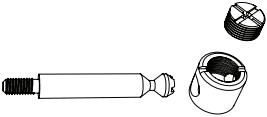
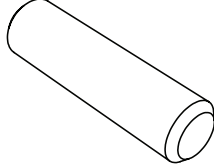

RST Brands / 1775 West 2300 South / Salt Lake City, Utah 84119
Ph: 801.924.2090 / www.rstbrands.com
Flow Wall is a registered trademark of Red Star Traders, LLC

Step 1.

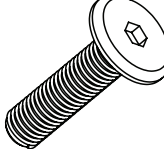
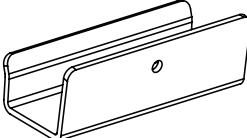
Parts List - Review this parts list and reference for future assembly steps. If you find any parts are missing, please contact Flow Wall via phone or email.

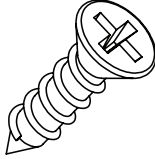
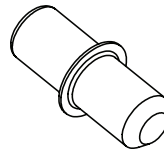
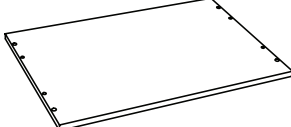
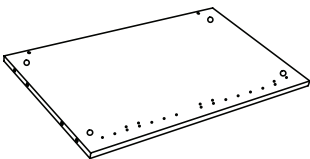
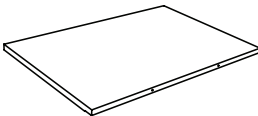
	A Cam & Post x8		B Wood Dowel x8
	C Steel Spanner x2		D Spanner Screw x4
	E Spanner Bracket x4		F Shelf Bracket x1
	G Shelf Screws x5		H Shelf Pin x2
	I Top / Bottom x2		J Side Panel x2
	K Shelf x1		



Step 2.

Mount Posts - ScREW post into receiver holes on Top & Bottom Panel.

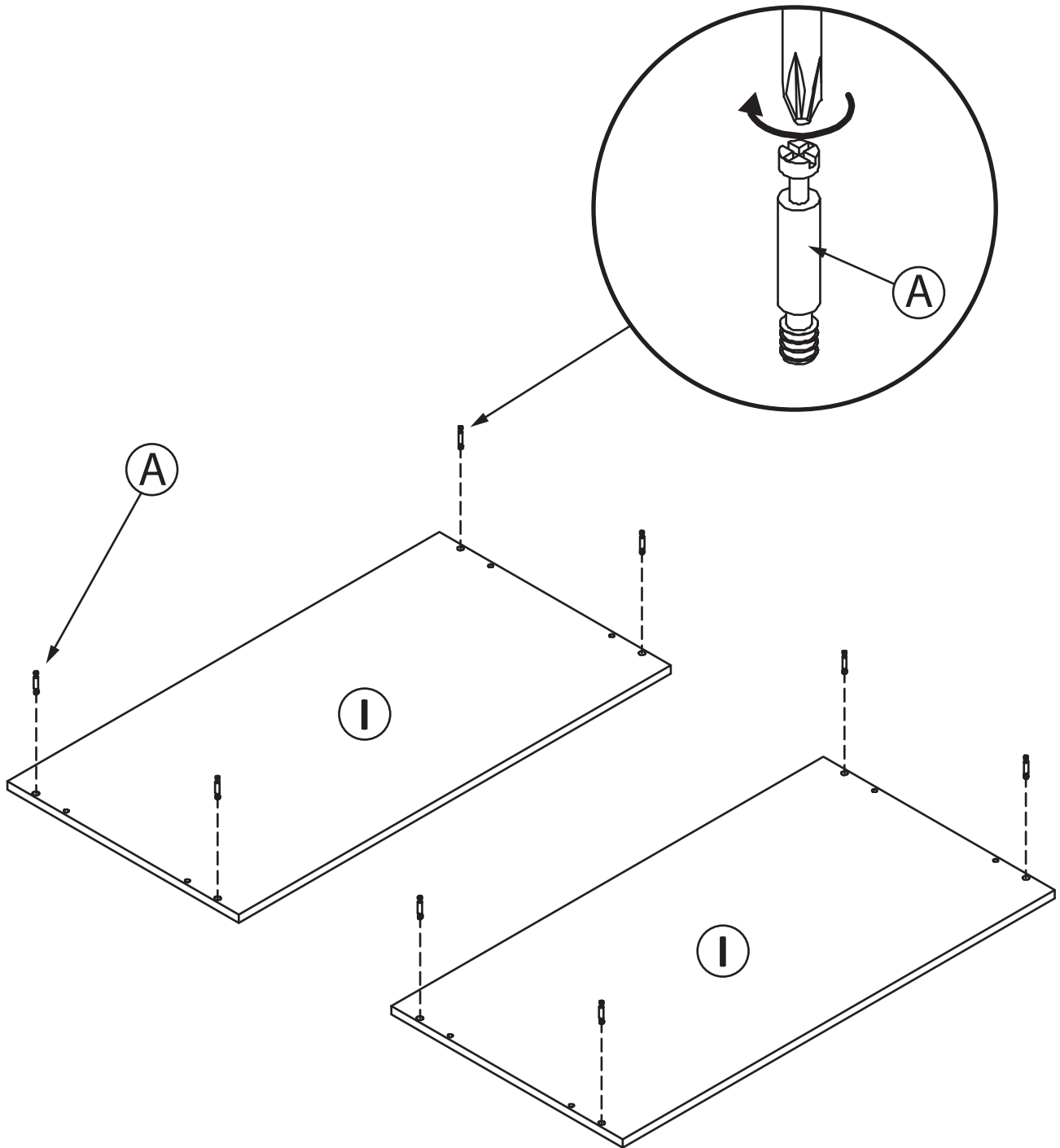

Step 3.

Side Panel - Glue and insert dowels into side panel.

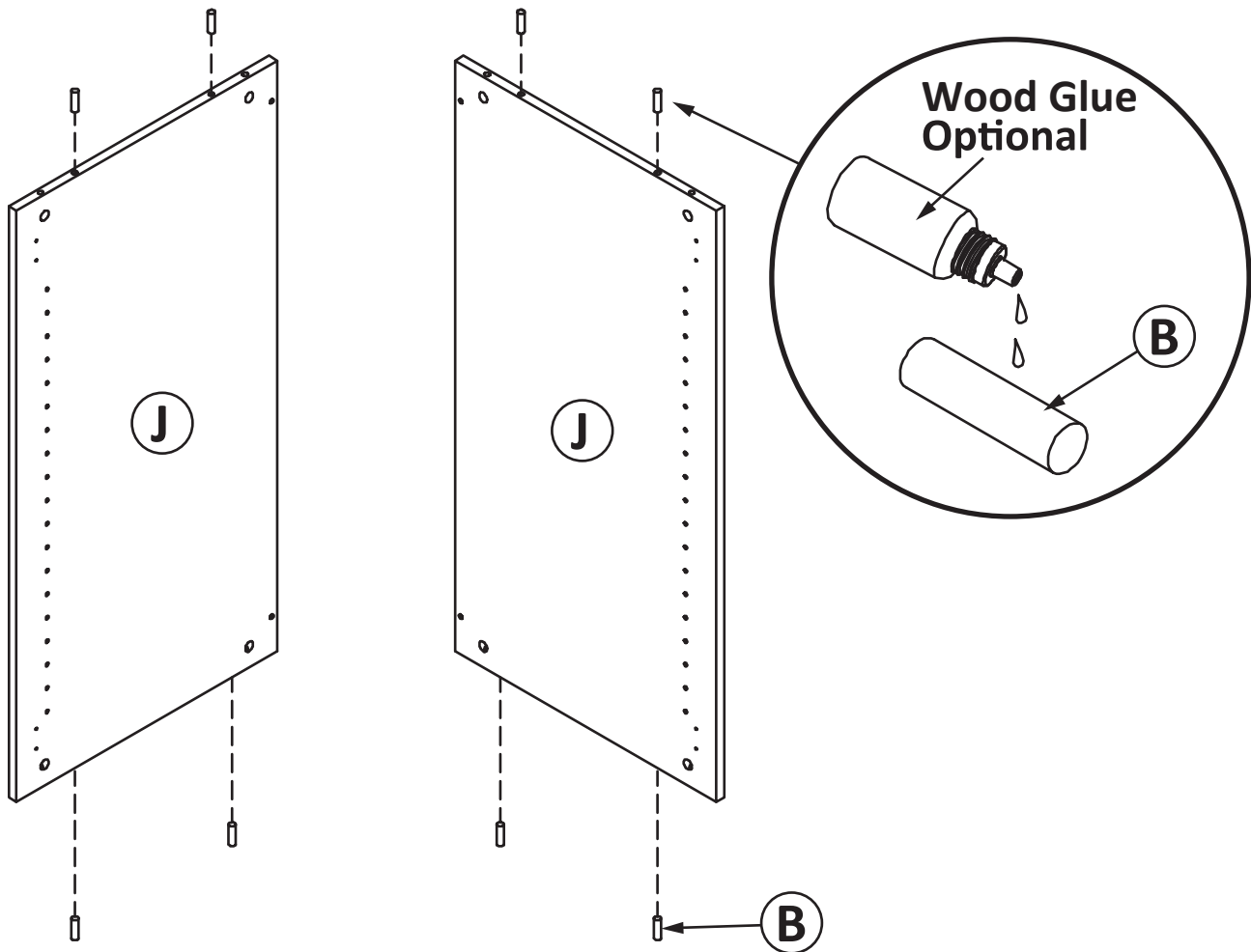

Step 4.

Assemble Cabinet Body - Use the top and bottom from Step 2 and assemble side panels. Assemble the box on its back as shown.

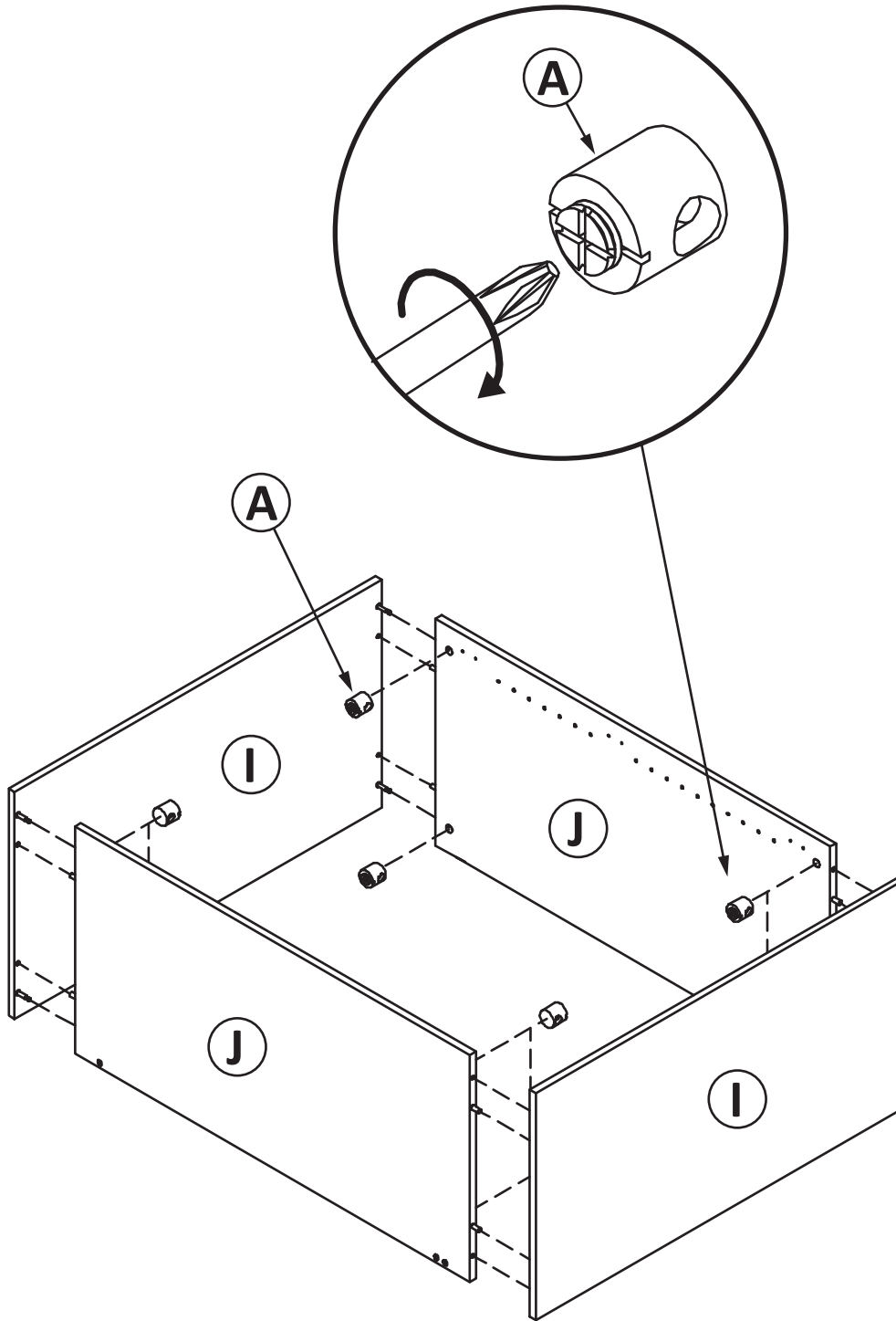

Step 5.

Add Spanner Brackets - Assemble the spanner brackets to your Flow Wall panel wherever you would like to hang your cabinet.

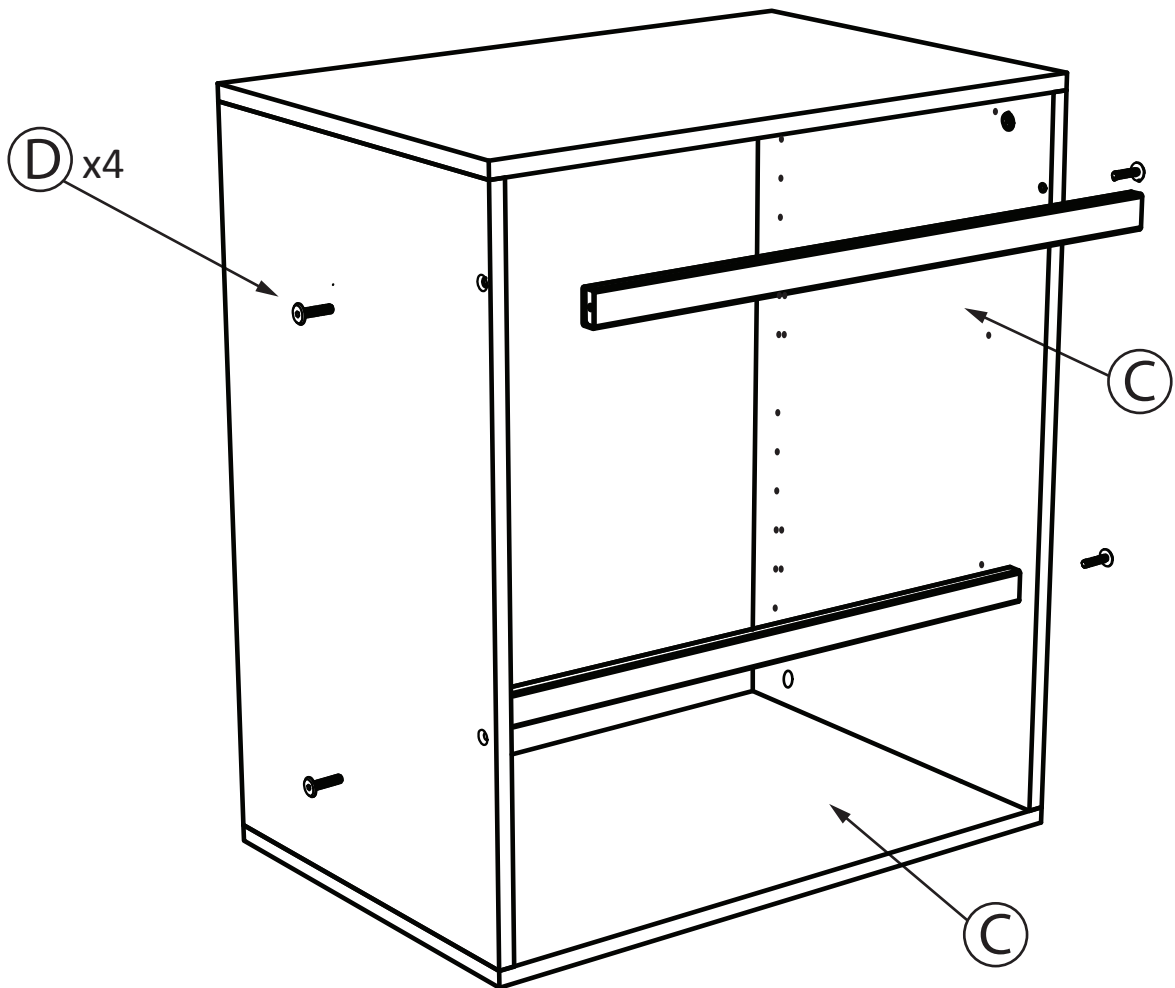
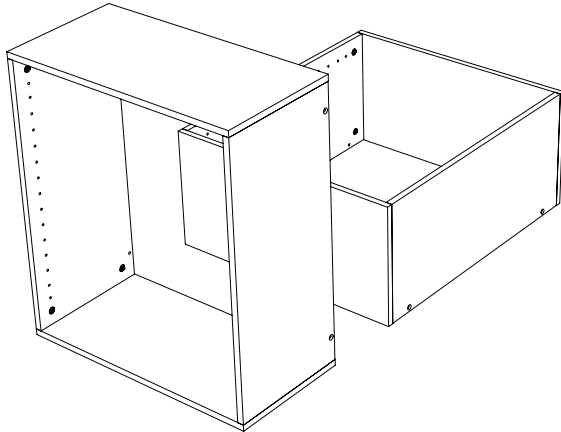

Step 6.

Hang the Cabinet - Hang the cabinet on the spanner brackets. After hanging, the cabinet can be adjusted side to side by sliding shell and brackets.

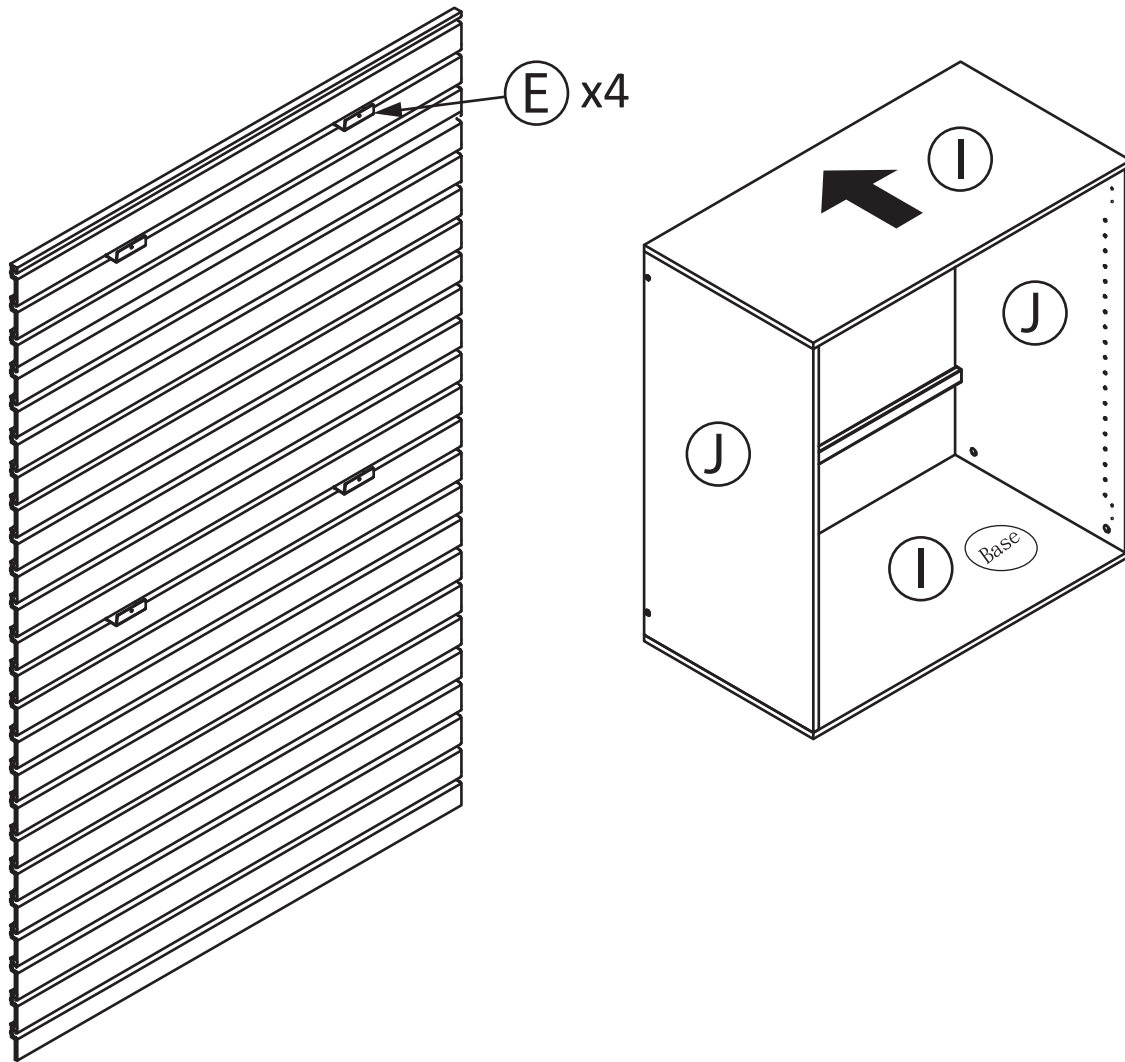
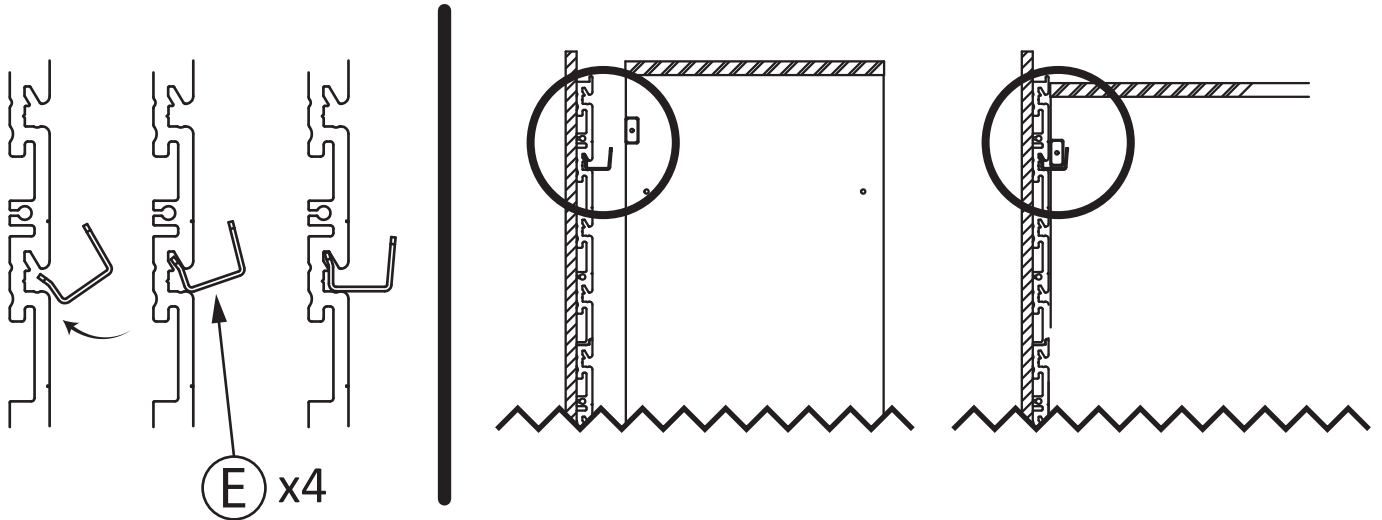

Step 7.

Assemble Shelf - Screw shelf bracket to the shelf using 5 screws.

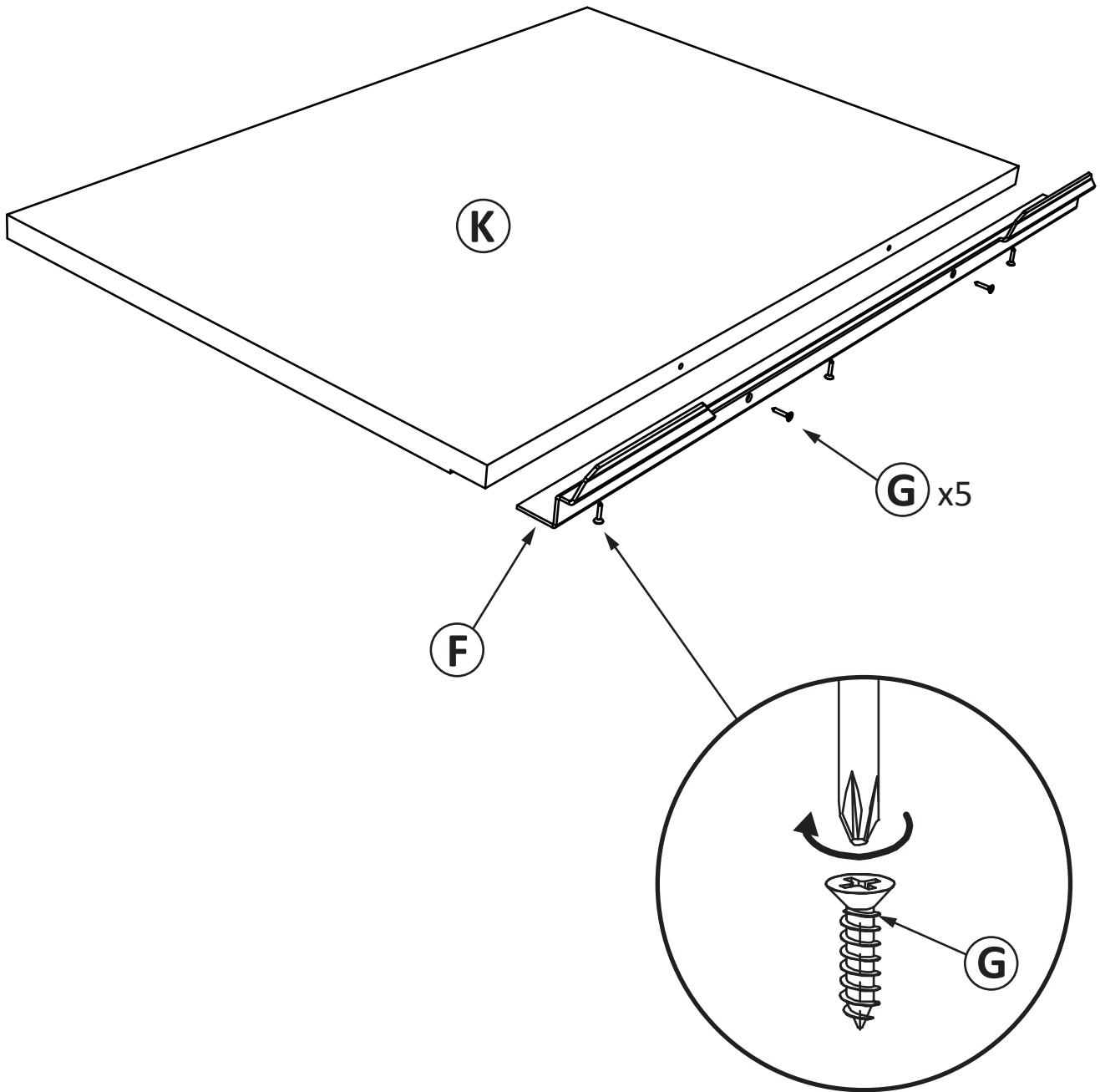



Step 8.

Insert Shelves - Hang the shelves from any slat on your wall in the back and then rest the front on the appropriate shelf pin.

