

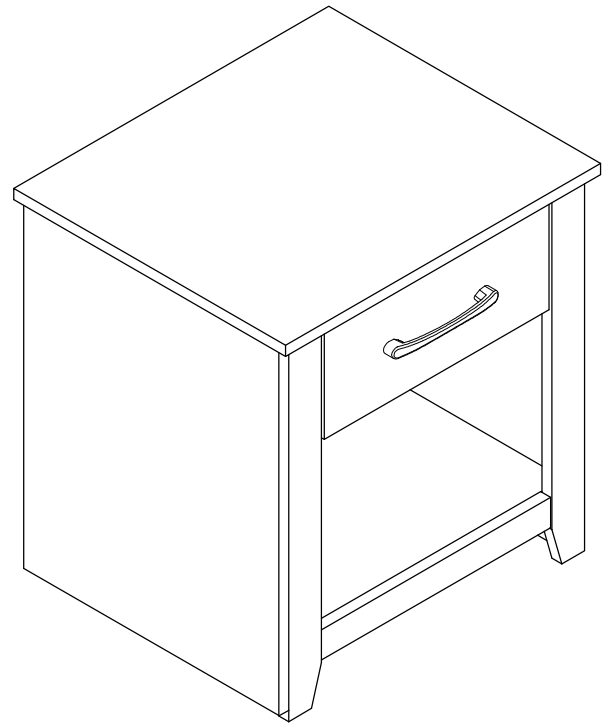

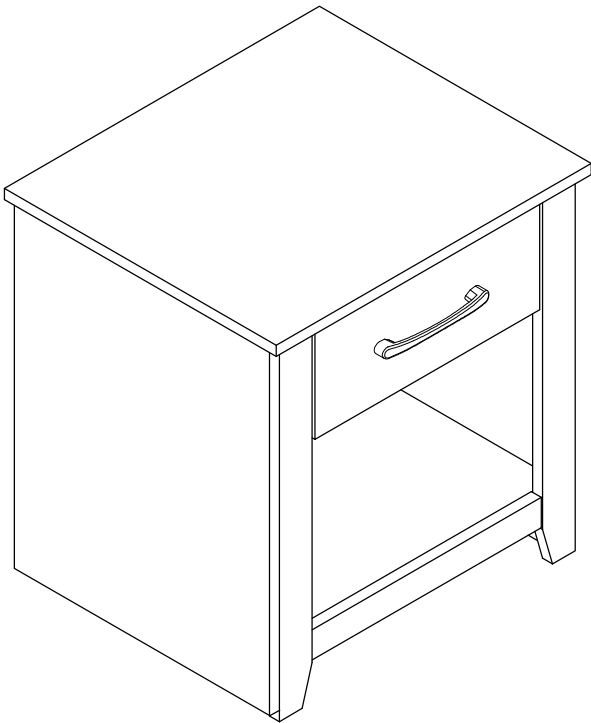



**ASSEMBLY INSTRUCTIONS / INSTRUCTIONS
D'ASSEMBLAGE / INSTRUCTIVO DE ARMADO**



NOTES ON ASSEMBLY / NOTES POUR L'ASSEMBLAGE / NOTAS SOBRE EL ENSAMBLE

- To ensure ease of assembly read all instructions before assembly and follow step by step illustrations.
- Keep instructions for future use.
- Adult assembly required.  2 person required. 
- Due to the presence of small parts during assembly, keep out of reach of children until assembly is complete.

- Pour assurer l'assemblage facile veuillez lire toutes les instructions avant l'assemblage et veuillez suivre les illustrations pour chaque etapes.
- Veuillez garder ces instructions pour l'usage ulterieur.
- Assemblage requis pas un adulte.  2 personnes requises. 
- Due a la presence de petite pieces durant l'assemblage, veuillez garder hors de porter des enfants jusqu'a ce que l'assemblage soit completer.

- Para garantizar la facilidad de ensamble lea las instrucciones antes de iniciar y siga paso a paso las ilustraciones.
- Guarde las instrucciones para futuras referencias.
- El ensamble requiere de un adulto.  2 personas requeridas. 
- Debido a que hay piezas pequeñas, mantenga fuera del alcance a los niños durante el ensamble, hasta que haya terminado.

MAINTENANCE TIPS / CONSEILS D'ENTRETIEN / CONSEJOS DE MANUTENIMIENTO

- Never let liquids or damp cloths sit on this furniture.
- Never use chemical cleaning products. They can damage the finish. For cleaning, use only a slightly damp cloth and wipe dry.
- To avoid dulling of the finish, do not place furniture in direct sunlight.
- Do not put plastic or rubber rings under appliances. Use cloth of felt protectors.
- To clean, use a soft or slightly damp cloth, then wipe with a clean, dry cloth.

- Ne jamais laisser de liquide ou linge humide sur le meuble.
- Ne jamais utiliser de nettoyeurs à base de produits chimiques, cela va endommager le fini. Utiliser seulement un linge légèrement humide.
- Ne pas placer le meuble directement au soleil pour prévenir le ternissement.
- Évitez de déposer des appareils avec des rondelles de plastique ou de caoutchouc. Utilisez un protecteur en tissu ou en feutre.
- Pour nettoyer, utilisez un linge doux ou légèrement humecté. Essuyez par la suite avec un linge propre et sec.

- Nunca deje un líquido o un trapo húmedo sobre el mueble.
- Nunca utilice limpiadores a base de químicos, estos dañaran le acabado. Use sólo un paño húmedo.
- No esponga el mueble directamente al sol para prevenir empañamiento.
- Evite apoyar aparatos con redondeles de plástico o de goma. Utilizar un protector de tela o de fieltro.
- Para limpiar, utilice un trapo suave o ligeramente humedecido. Seque luego con un trapo limpio y seco.

MINIFIX CAM & MINIFIX BOLT & WOOD DOWEL
CAMÉRA MINIFIX & BOULON MINIFIX & CHEVILLE BOIS
CÁMARA MINIFIX & PERNO MINIFIX & PASADOR DE MADERA

MINIFIX BOLT
BOULON MINIFIX
PERNO MINIFIX

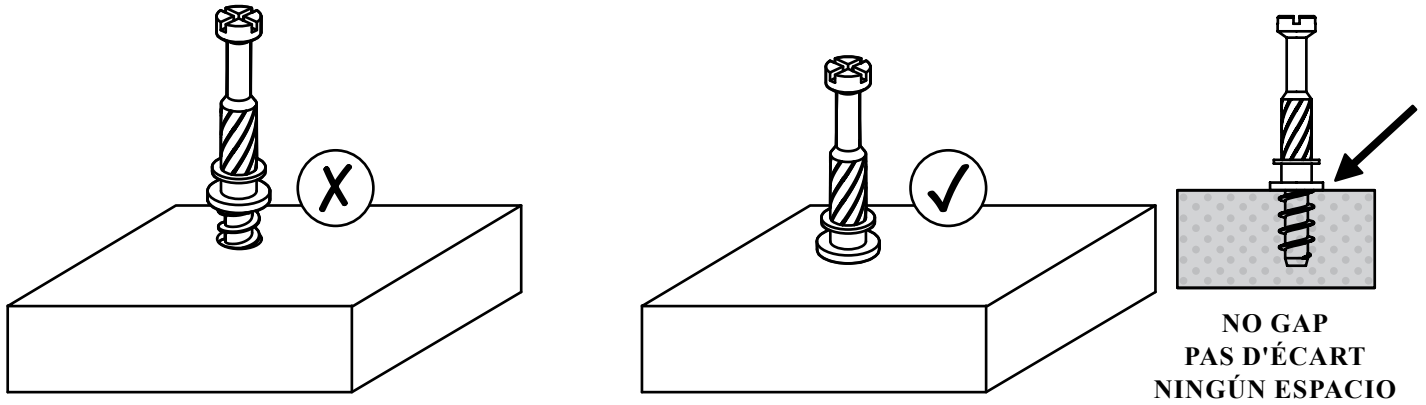

MINIFIX CAM
CAMÉRA MINIFIX
CÁMARA MINIFIX

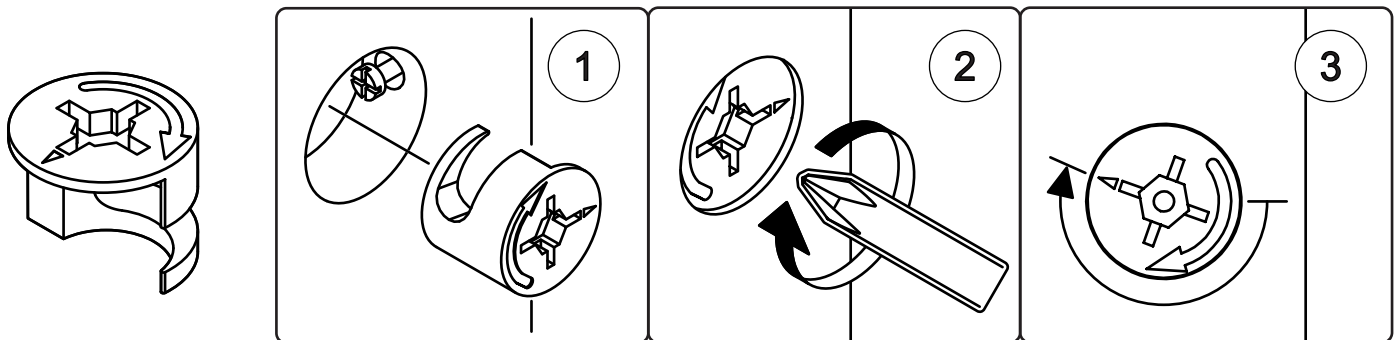

WOOD DOWEL
CHEVILLE BOIS
PASADOR DE MADERA

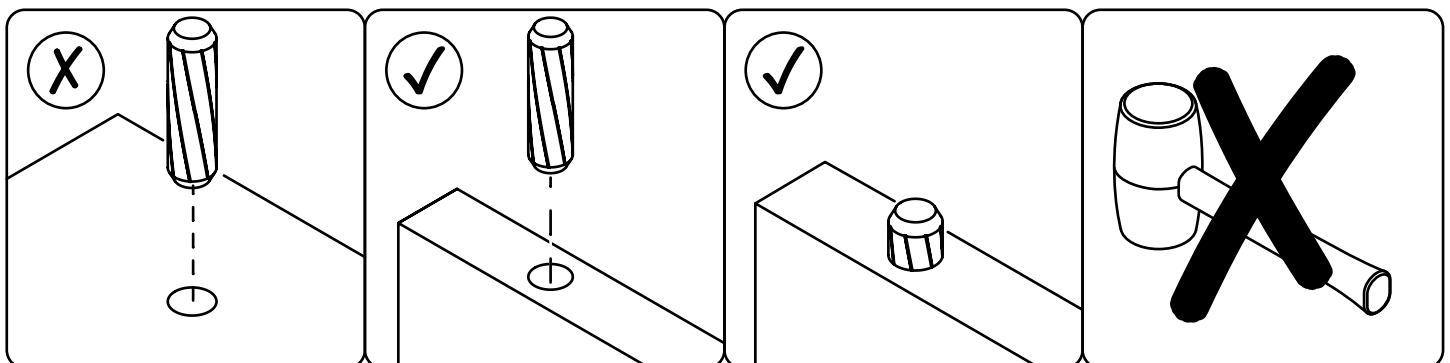

SPECIAL TIPS FOR FITTING DRAWER

CONSEJOS ESPECIALES PARA EL MONTAJE DEL CAJÓN

CONSEILS SPÉCIAUX POUR LE MONTAGE DU TIROIR

DRAWER SLIDE - CABINET MEMBER - LEFT

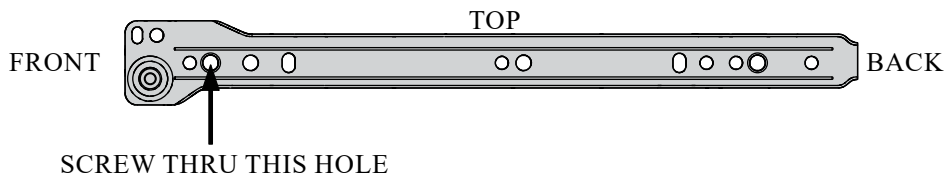

DRAWER SLIDE - CABINET MEMBER - RIGHT

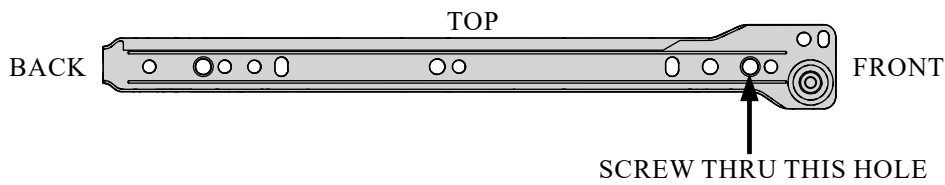

DRAWER SLIDE - DRAWER MEMBER - LEFT AND RIGHT

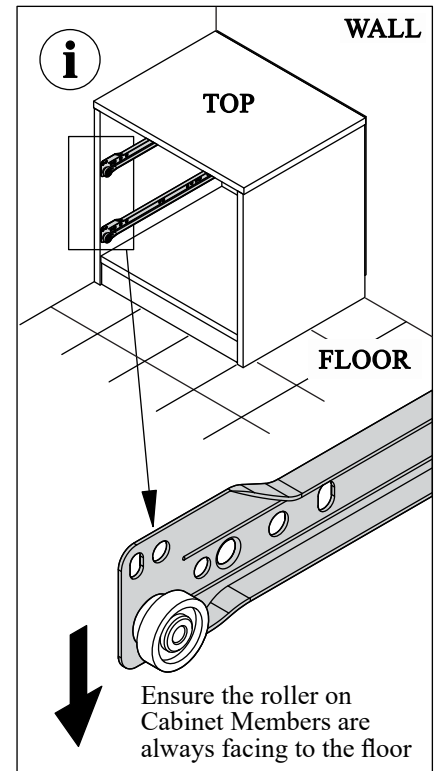
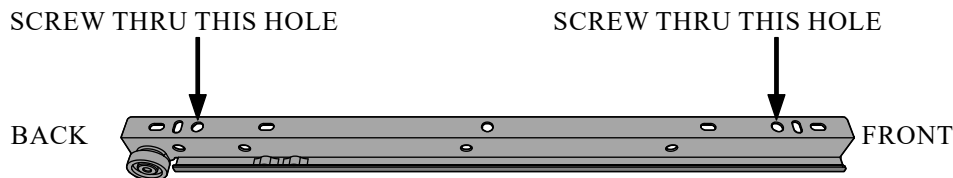
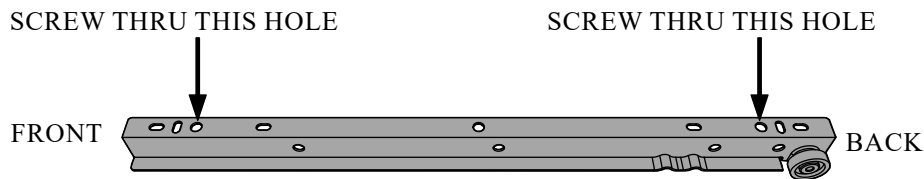

Ensure the drawer members are fully pushed to drawer front

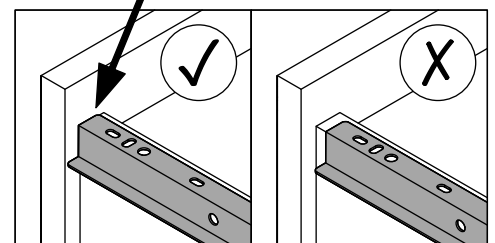

INSTALL DRAWER TO CABINET

INSTALE EL CAJÓN AL GABINETE



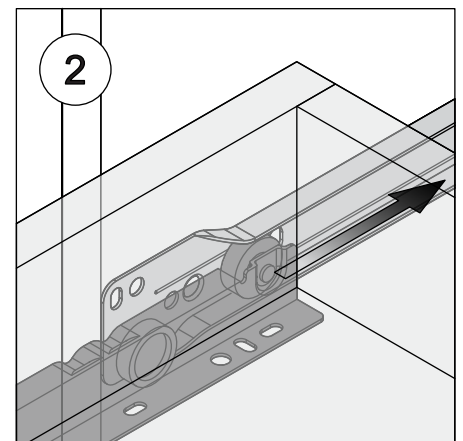
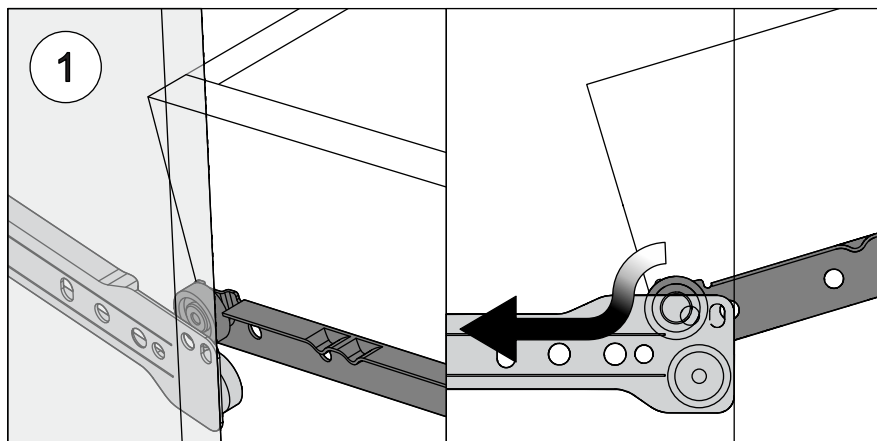

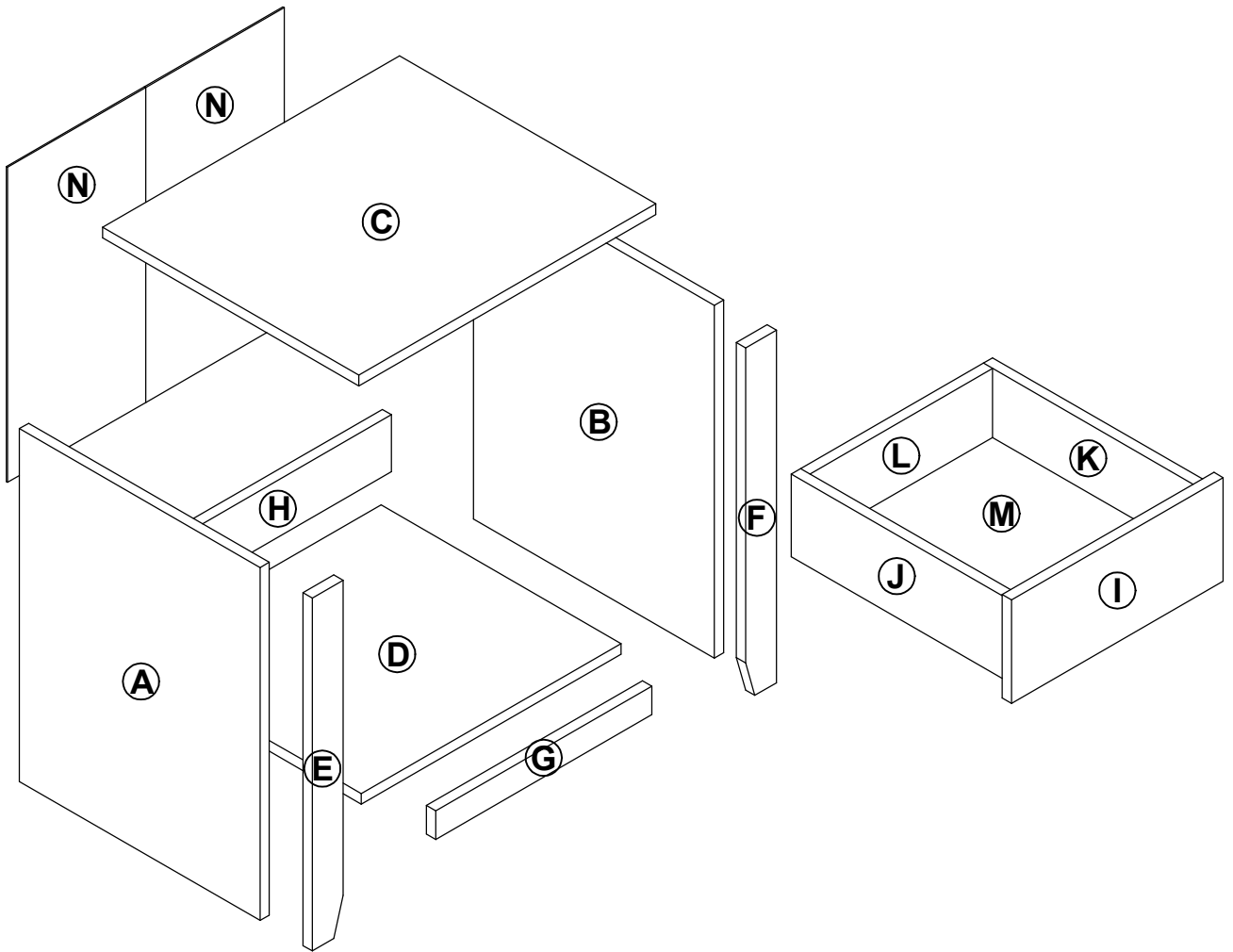



INSTALLER LE TIROIR SUR L'ARMOIRE

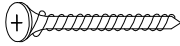
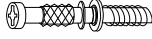

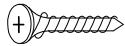
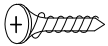
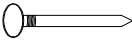

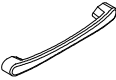
HARDWARE

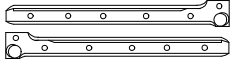
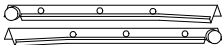
QUINCAILLERIE / HERRAJE

(A)	Screw M4 x 38mm  8 units	(B)	Cam Bolt  32 units	(C)	Dowel Ø8 x 30mm  38 + 2 units
(D)	Screw M4 x 19mm  4 units	(E)	Screw M4 x 20mm  16 + 2 units	(F)	Screw M3.5 x 15mm  16 + 2 units
(G)	Nail Pin  20 units	(H)	Floor Glide  8 units	(I)	Cam Lock  32 units
(J)	Bar Handle  2 units	(K)	PVC Block  8 units	(L)	Cabinet Member 14"  2 sets
(M)	Drawer Member 14"  2 sets	(N)	Hex Key M4  1 unit		

- Hardware quantity may supplied more than it required. Please keep spares and tools for future use.
- La cantidad de hardware puede suministrarse más de lo requerido. Guarde los repuestos y las herramientas para uso futuro.
- La quantité de matériel peut fournir plus que nécessaire. Veuillez conserver les pièces de rechange et les outils pour une utilisation future.

TOOLS NOT INCLUDED

OUTILS PAS INCLUS / HERRAMIENTAS NO INCLUIDAS

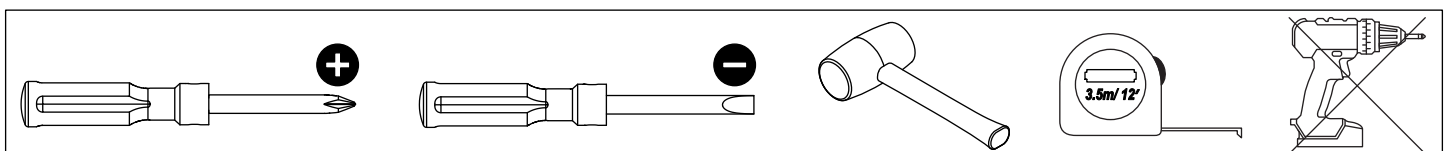

STEP 1

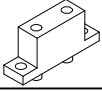
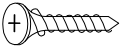
	
K x 8	E x 16

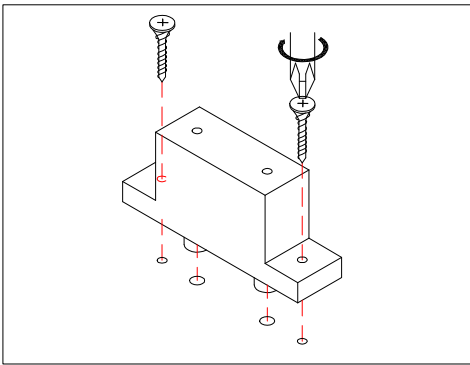
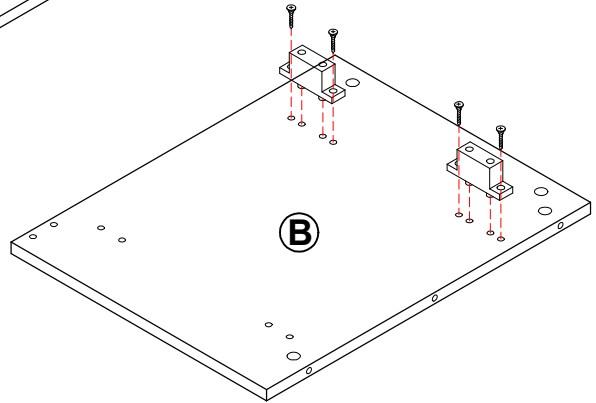
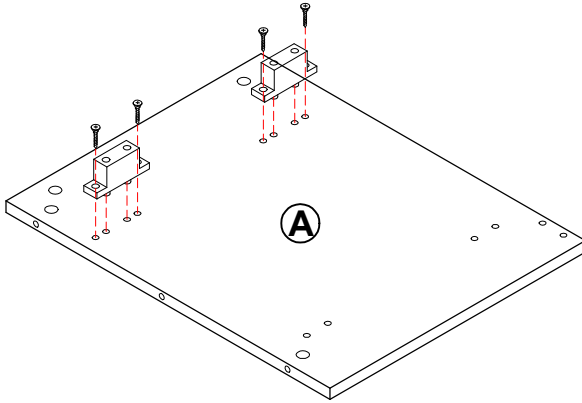

(2x)

STEP 2

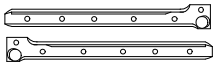
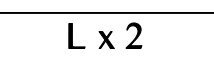
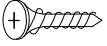
 	
L x 2	F x 8

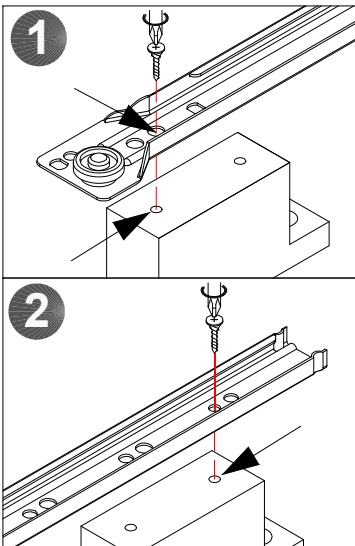
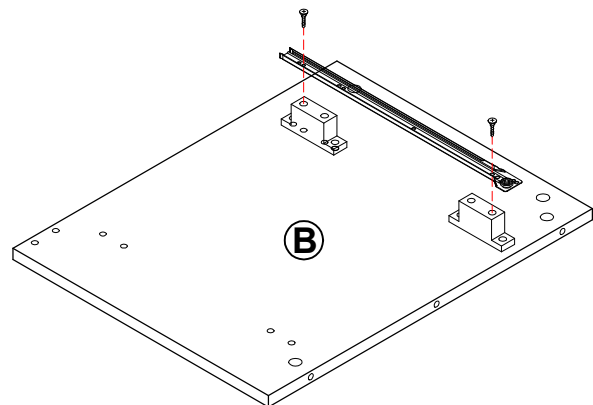
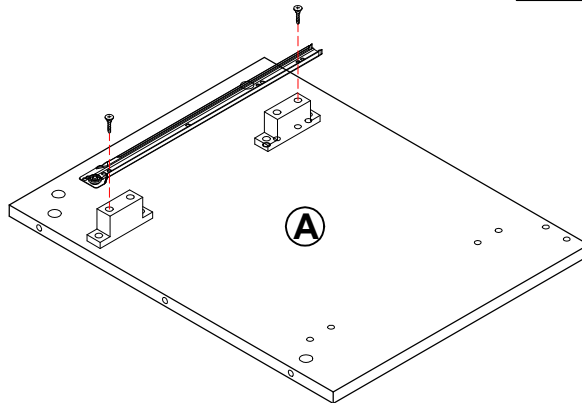

(2x)

STEP 3

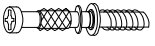
	
H x 8	B x 8

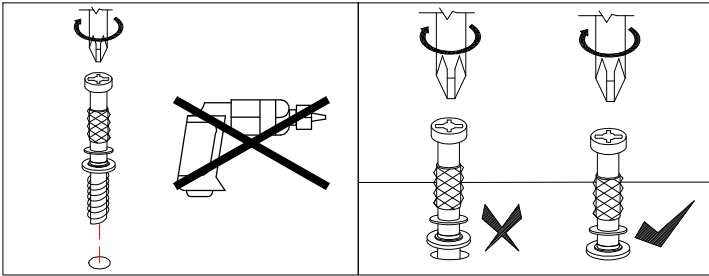
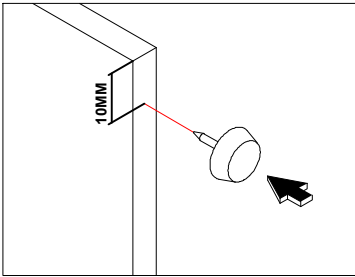
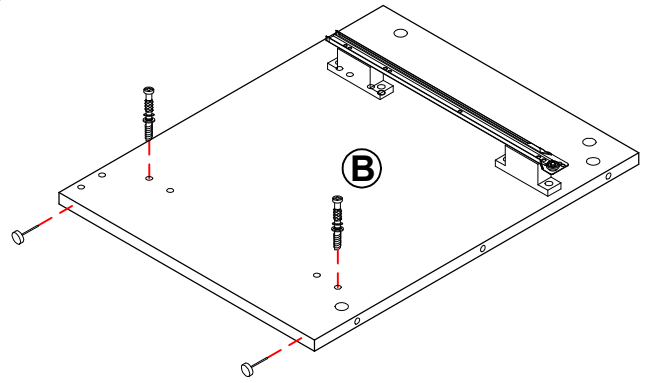
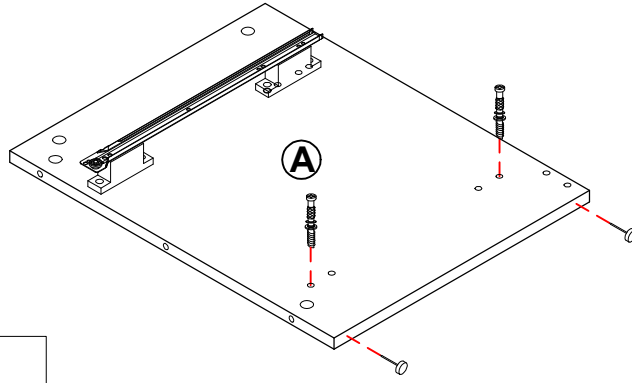

(2x)

STEP 4

B x 20

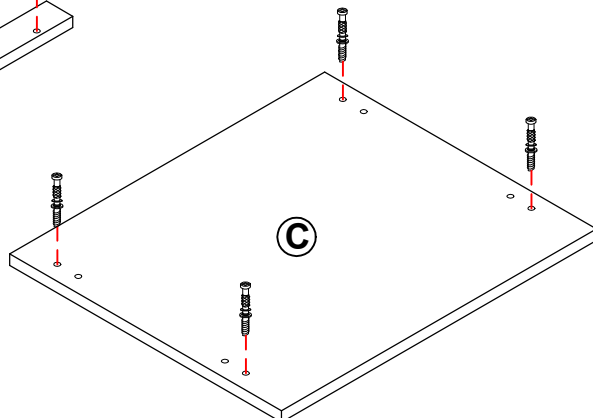
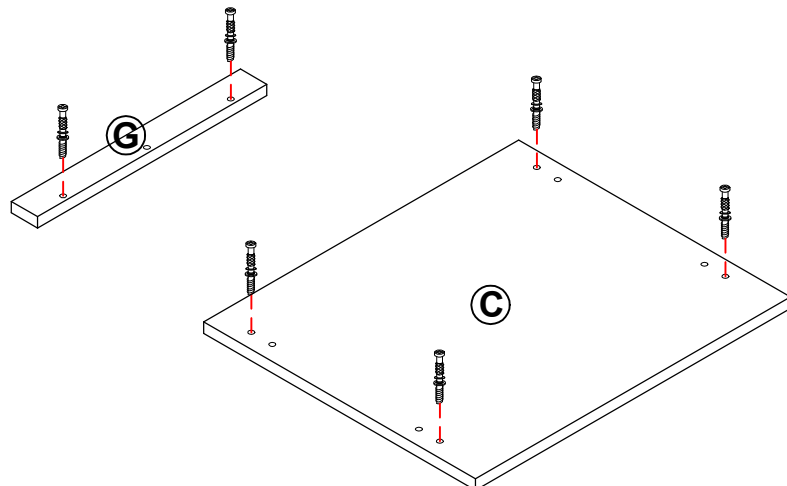
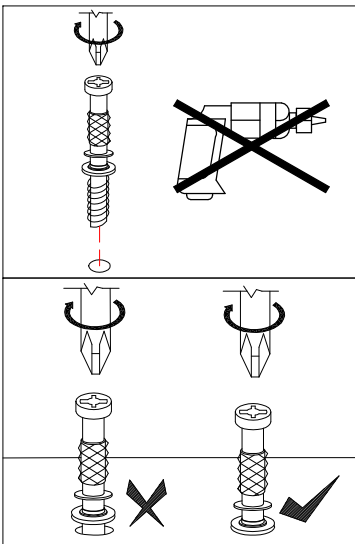
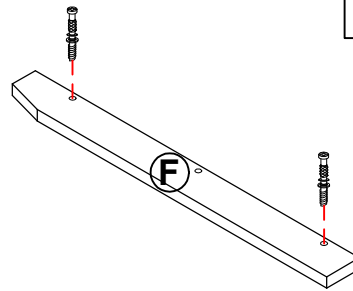
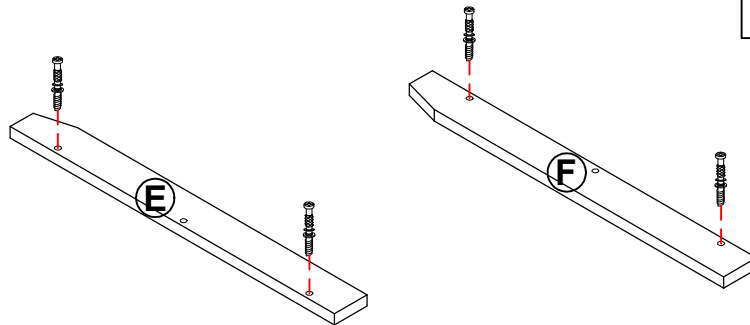

(2x)

STEP 5

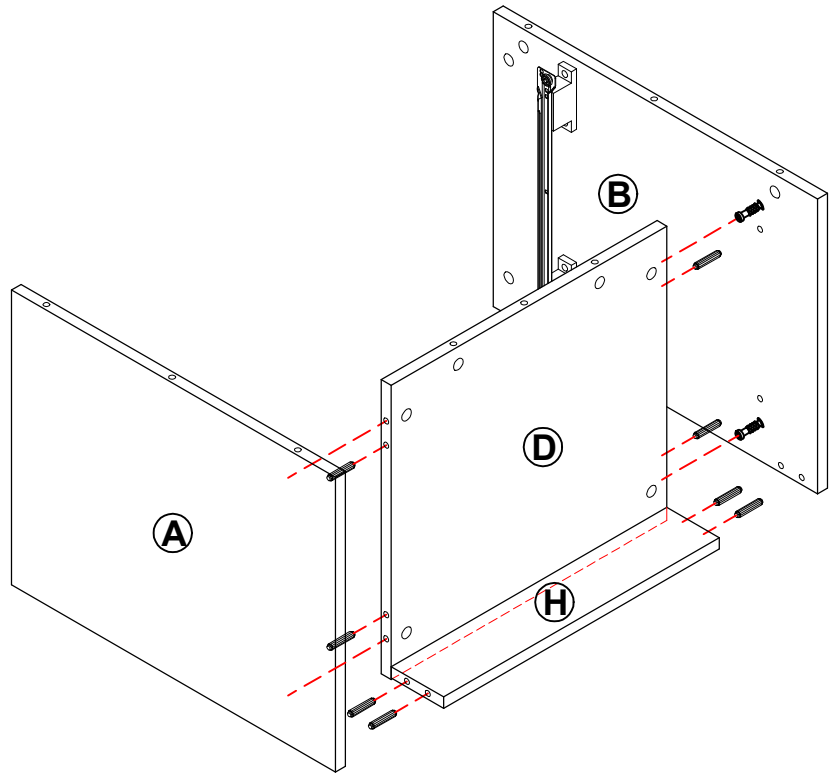
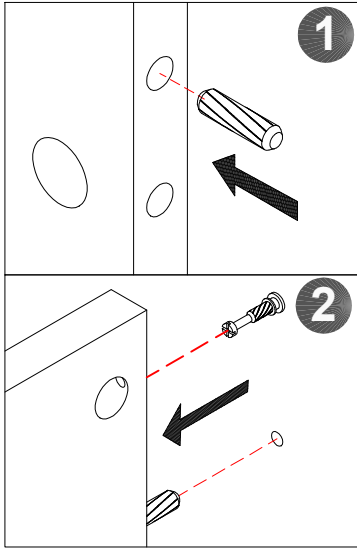
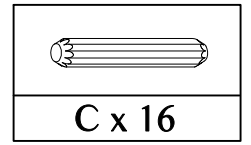

(2x)

STEP 6

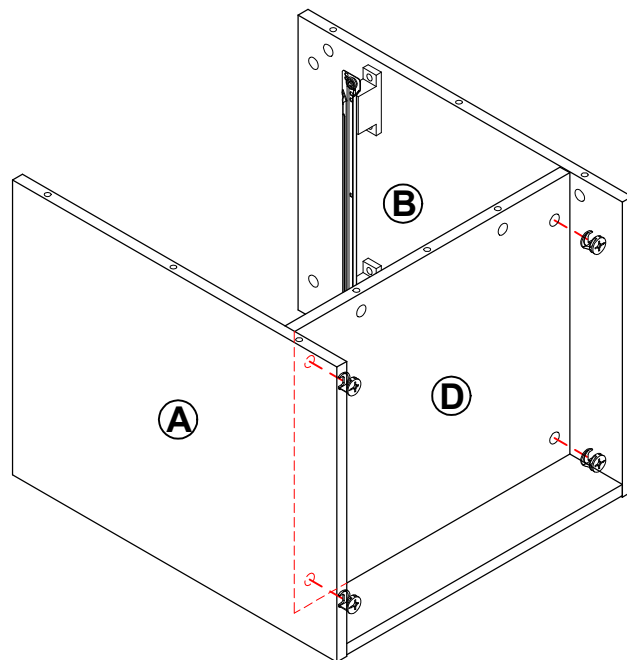
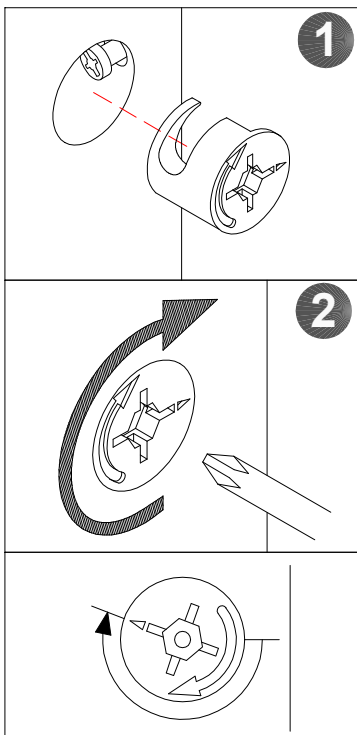
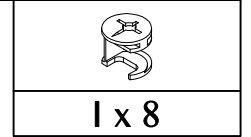

(2x)

STEP 7

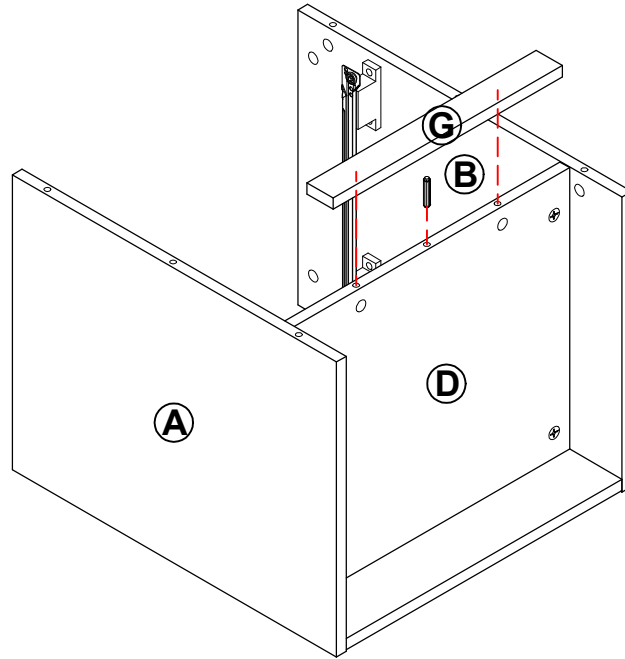
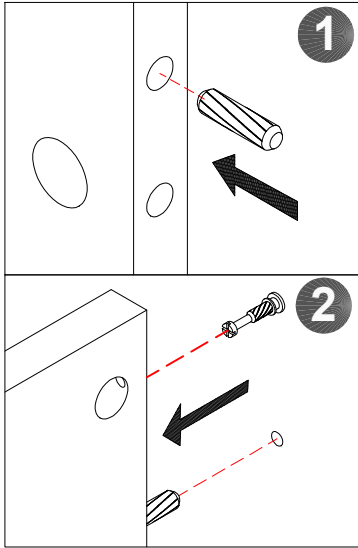
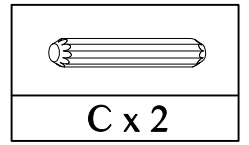

(2x)

STEP 8

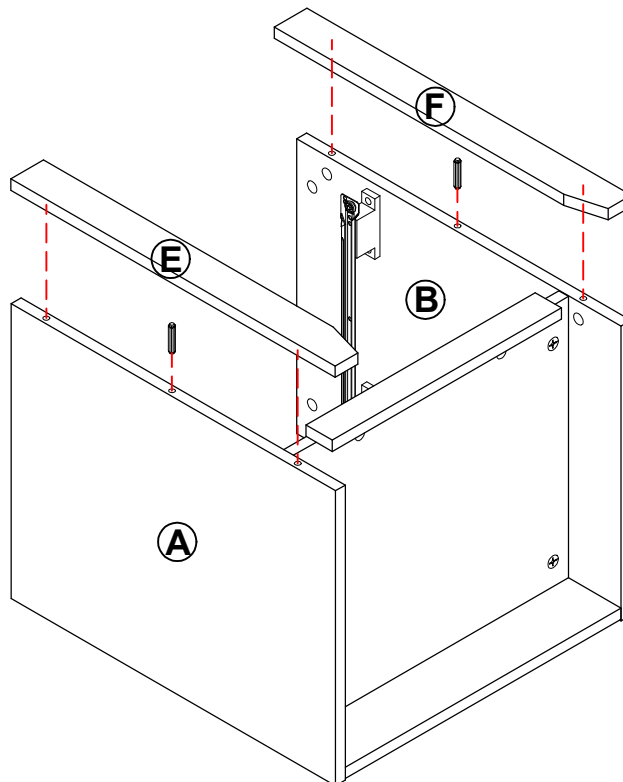
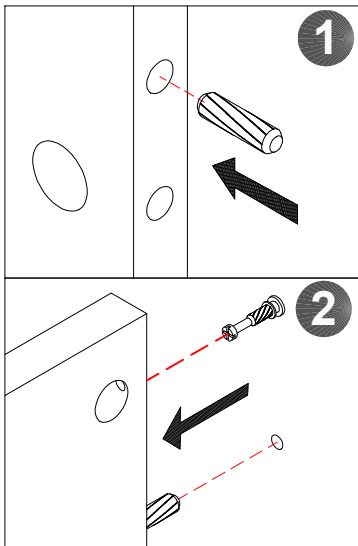
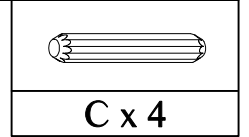

(2x)

STEP 9

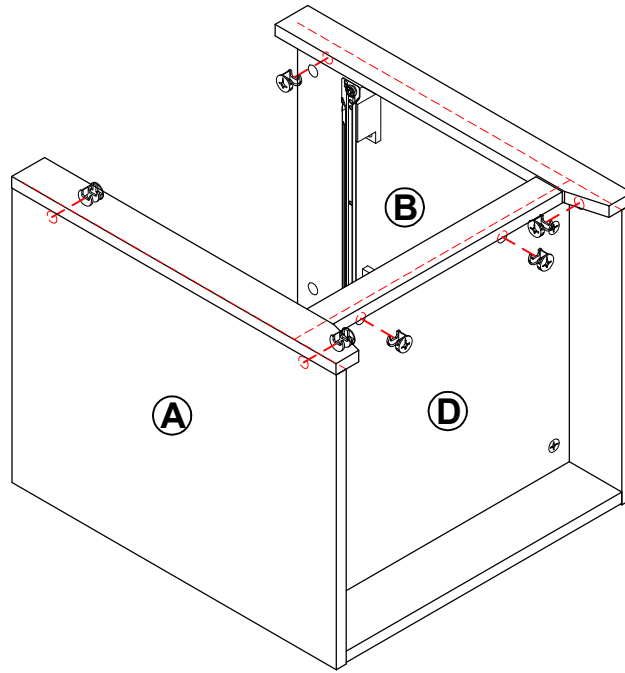
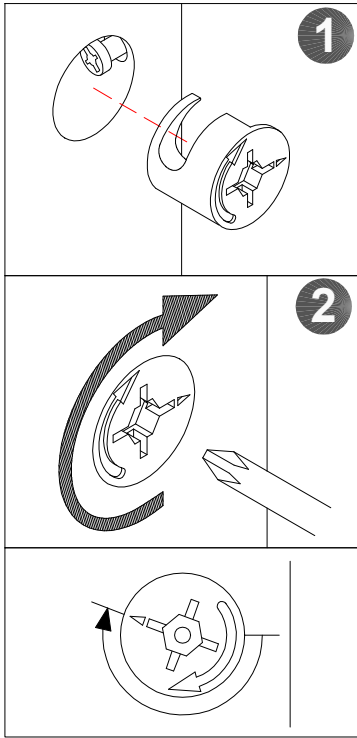
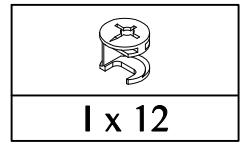

(2x)

STEP 10

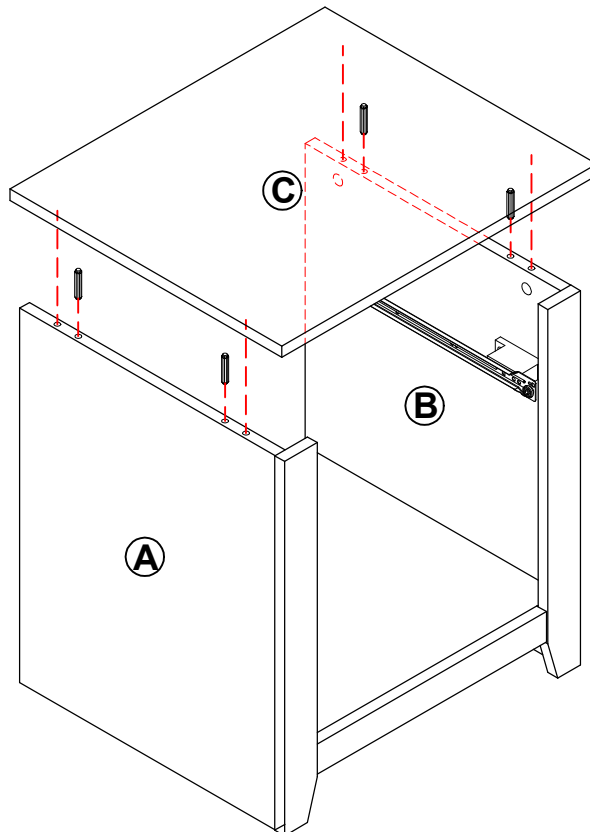
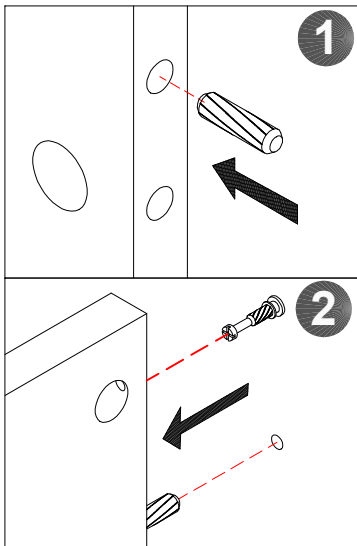
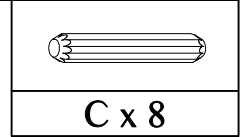

(2x)

STEP 11

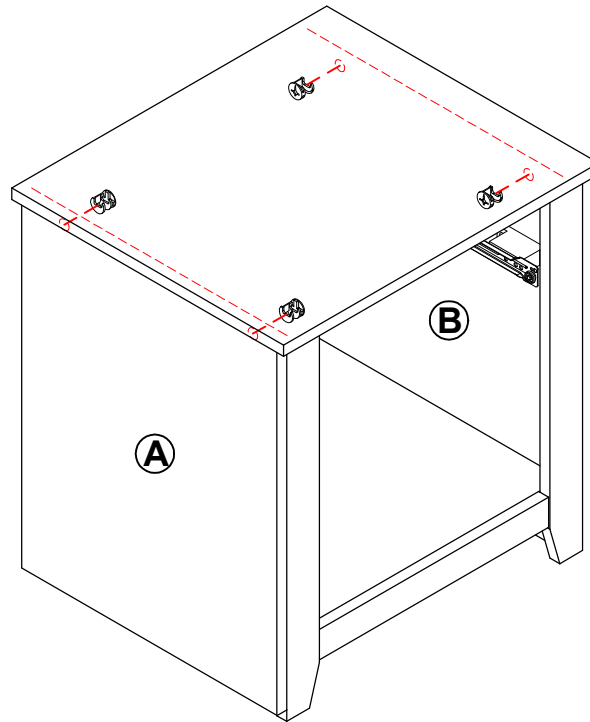
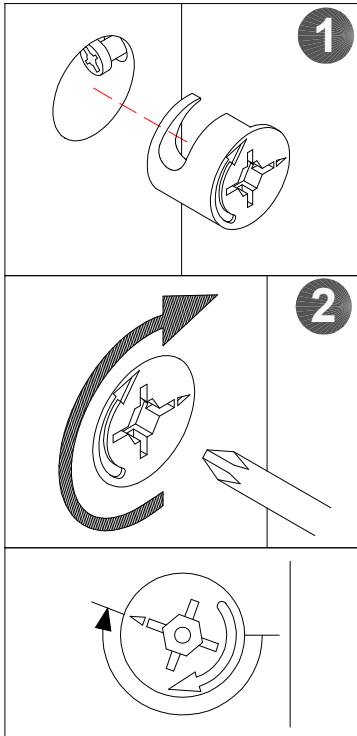
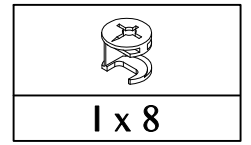

(2x)

STEP 12

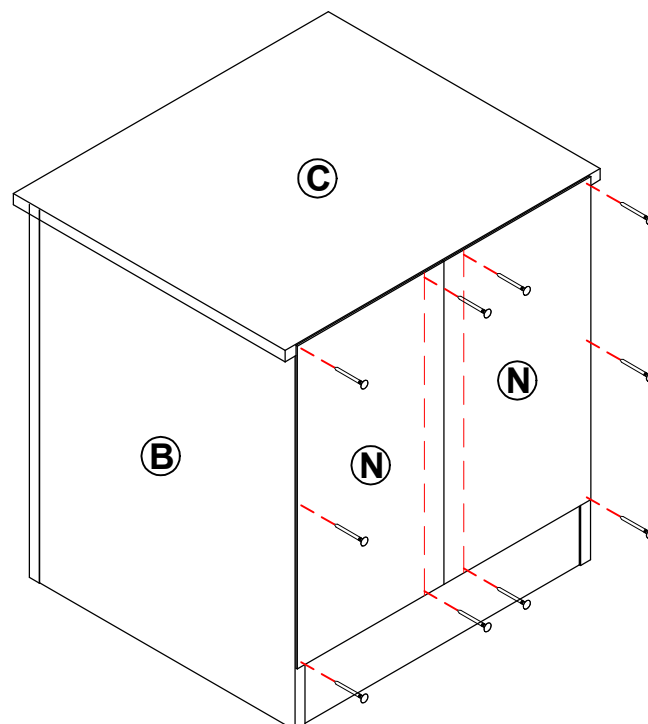
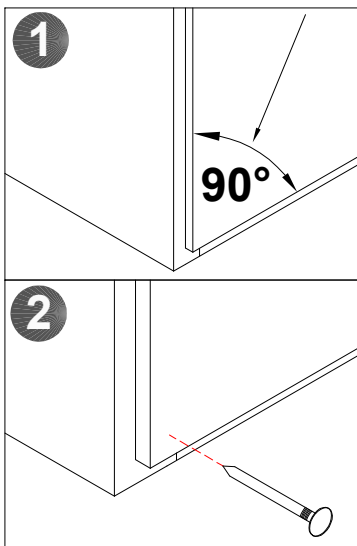
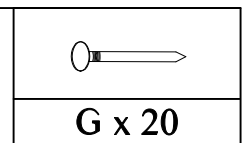

(2x)

STEP 13

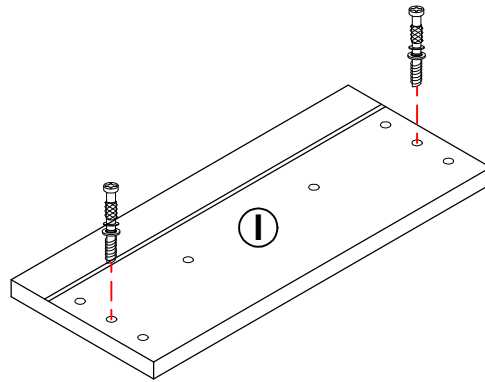
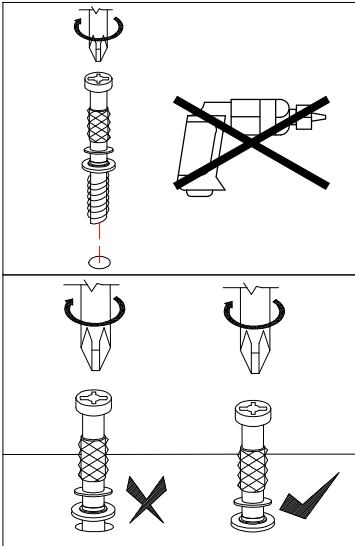
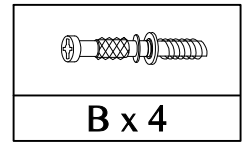

(2x)

STEP 14

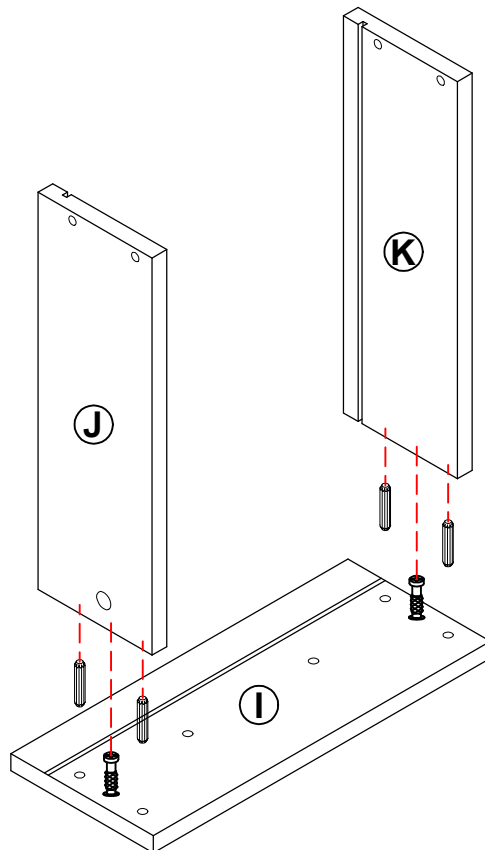
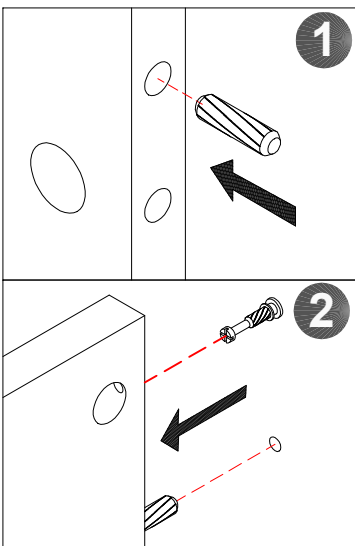
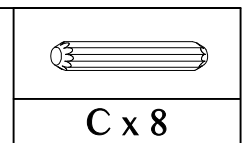

(2x)

STEP 15

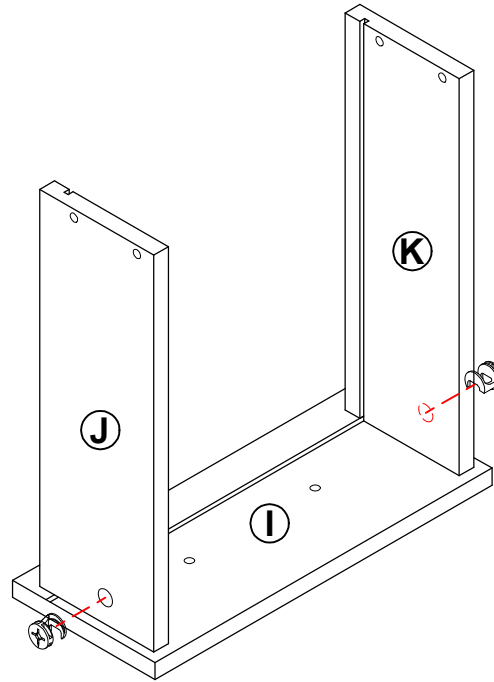
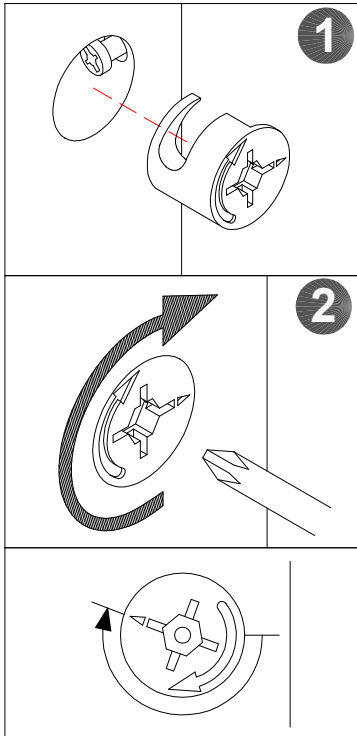
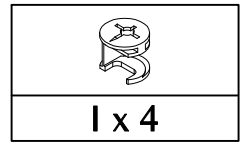

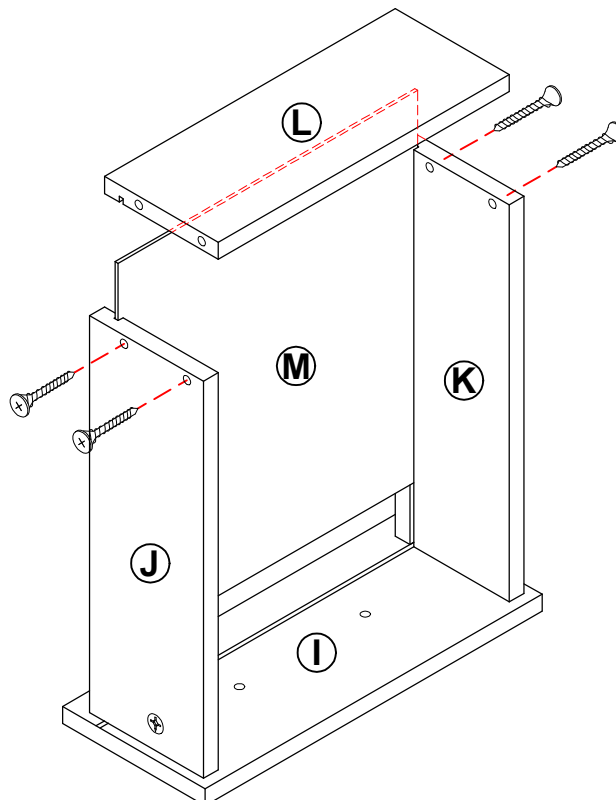
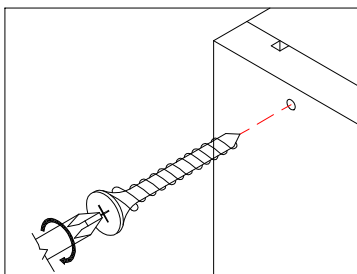
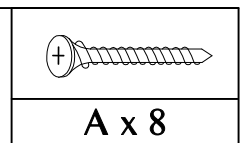

(2x)

STEP 16

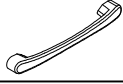

(2x)

STEP 17

	
J x 2	D x 4

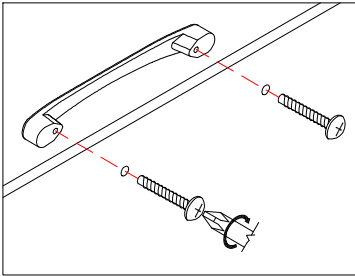
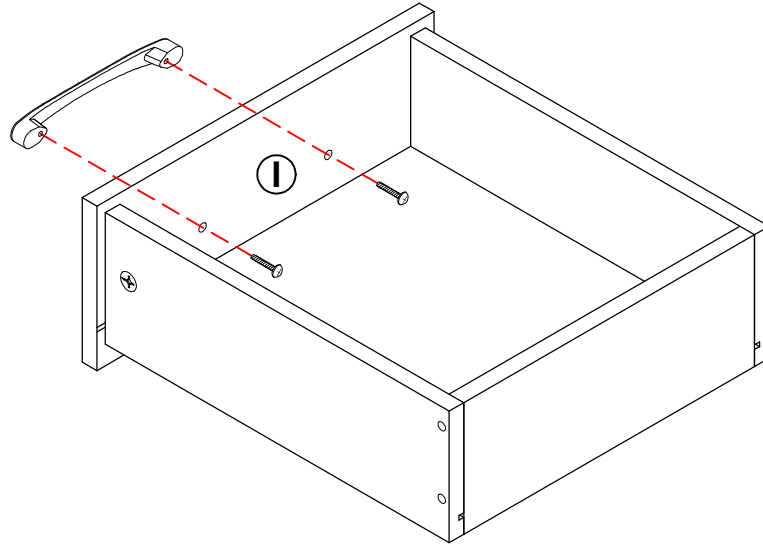

(2x)

STEP 18

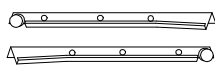
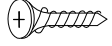
	
M x 2	F x 8

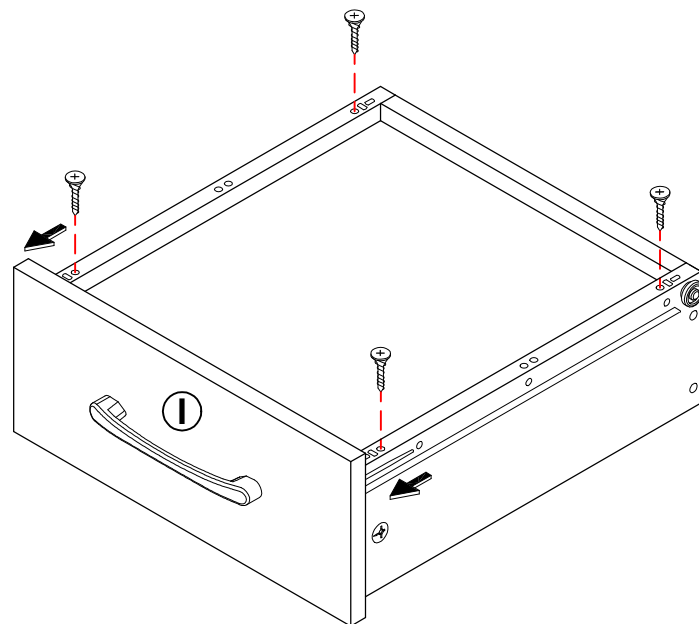
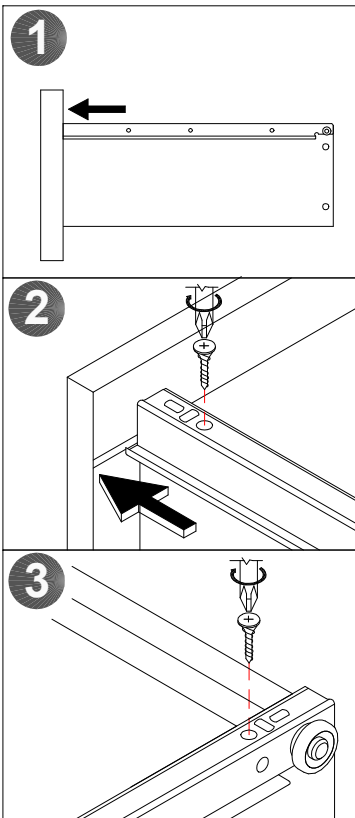

(2x)

STEP 19

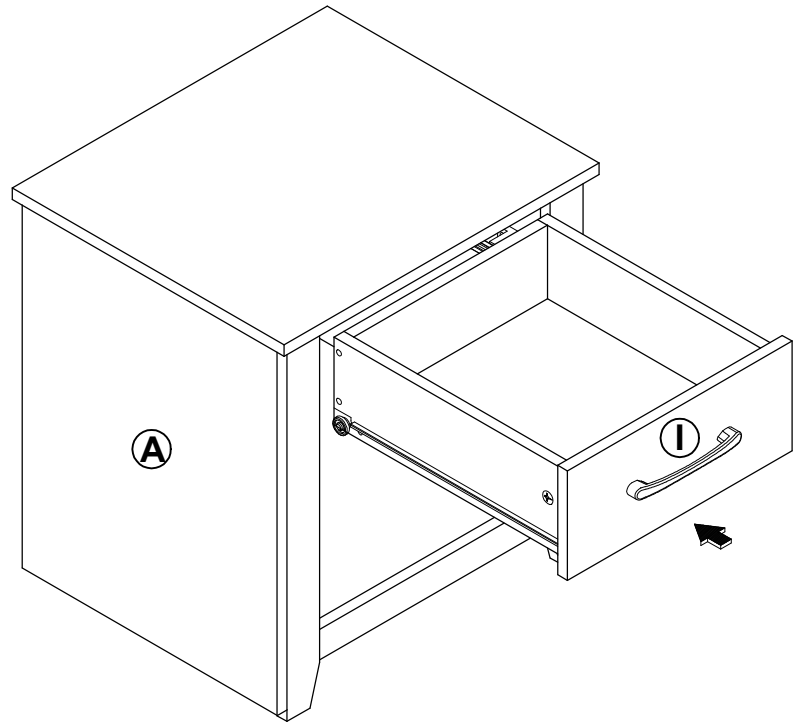
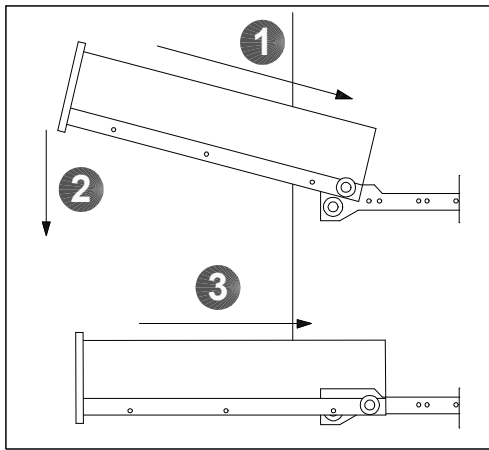

(2x)

STEP 20

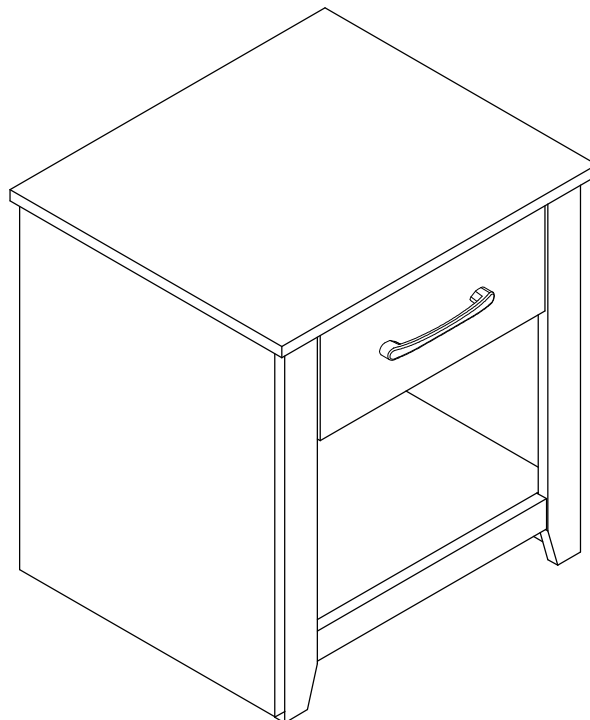

(2x)

MAXIMUM LOADS CHARGES MAXIMALES / CARGA MAXIMA

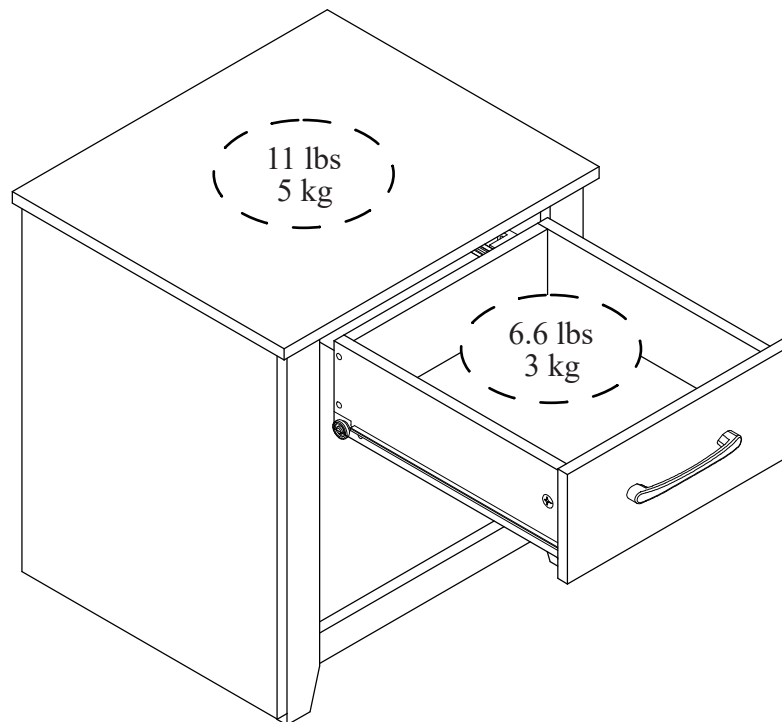

This unit has been designed to support the maximum loads shown. Exceeding these load limits could cause sagging, instability, product collapse, and/or serious injury.

Ce meuble a été conçu pour supporter les charges maximales indiquées. En excédant ces limites de charge, le meuble pourrait devenir instable, s'effondrer, et/ou causer des blessures graves.

Esta unidad ha sido diseñada para soportar la carga máxima anotada. El exceder estos límites puede causar inestabilidad, colapsarse y/o causar serias lesiones.
