

**These instructions are for your safety. Please read through them thoroughly before use .
PLEASE KEEP THIS BOOKLET FOR FUTURE REFERENCE**

Let's get started...



Important information...

Safety	03
Base and positioning	04
Warranty	04
Before you start	12
Care maintenance & Recycling	05



In more detail...

Hardware chart	06
Parts List	07
Detailed Technical Drawing	08-11
Assembly instructions	13-24

EN	For a copy of the instructions or a copy in another language please send an email or write to the address below.
F	Pour obtenir un exemplaire des instructions ou une copie dans une autre langue s'il vous plaît envoyez un e-mail ou écrire à l'adresse ci-dessous.
PL	Na kopii instrukcji lub kopii w innym języku prosimy o wysłanie maila lub pisać na adres podany poniżej.
RUS	Для получения копии инструкции или копия на другом языке, пожалуйста, отправьте по электронной почте или написать по указанному ниже адресу.
TR	Başka bir dilde talimatları veya bir kopyasını bir kopyası için bir e-posta gönderebilir veya aşağıdaki adrese yazınız.

Check that you have noted all the following instructions



- We advise the use of non slip protective gloves throughout the assembly process.
- We advise the use of steel capped protective footwear throughout the assembly process
- We advise that you use a helper to hold the glass in position whilst you nail the beading in place
- We advise the use of protective headwear and safety goggles throughout the assembly process
- Where a ladder is in use another person must hold the ladder.
- Do not attempt to work in windy conditions
- We advise the use of a scaffold tower when fitting the roof , for felting or if you cannot reach from the ground.
- Do not allow children near the tools and work area
- Follow any safety precautions quoted by the manufacturer for any equipment you use
- Check all parts before assembly
- Only use child and animal safe wood preservative
- Do not use creosote
- Allow the wood preservative to fully dry before use
- Regularly check the building for wear and tear

Important!



EVERY PRECAUTION IS TAKEN TO ENSURE THAT YOUR BUILDING HAS NO ELEMENT INCORRECTLY PLACED OR POSSIBLY HAZARDOUS, HOWEVER PRIOR TO USE PLEASE CHECK ALL SURFACES FOR THE FOLLOWING:

- (1) RAISED GRAIN, SPLINTERS: Sand down timber to smooth finish
- (2) NAIL/SCREW/PIN HEADS PROUD: Tap home to be flush with surface of timber
- (3) DAMAGED SCREW HEADS RESULTING IN SHARP SPLINTERS OF METAL: Replace
- (4) SHARP ENDS OF NAILS/ SCREWS/ PINS PROTRUDING THROUGH THE PANEL: Remove and reposition.
- (5) ENSURE ALL PARTS ARE SECURED AGAINST REASONABLE FORCE: Remove and refit
- (6) ENSURE THERE ARE NO LOOSE PARTS: Remove and refit/discard



IMPORTANT ! For your safety please read carefully the safety warnings

Preparation of base...

We recommend that the base onto which your building will stand should be at least 75mm larger in each direction than the total floor size of the building.

Actual floor area of the building: 2248mm x 2248mm

Total height clearance: 2140mm

The chosen position in your garden for the siting of the building should be excavated to a depth of 75mm to allow a base of sand, on to which paving slabs can be evenly laid.

You may also use an adjustable timber base or a concrete base. Whatever base you decide upon IT MUST BE LEVEL AND FIRM.

Warranty...

The 5 golden rules of care

- (1) Ensure your base is level and firm
- (2) Ensure the building is not sitting directly on the ground using damp proof membrane or the optional timber base.
- (3) Ensure every piece of timber and surface, especially that which will be hidden upon assembly is treated with a top quality wood preservative at least twice (see note on pressure treated buildings in warranty section)
- (4) Garden buildings are not waterproof we recommend you seal between all the panels with a silicone based sealant .
- (5) Regularly check your roofing felt for weather damage and leaks

The 7 golden rules of maintenance

- (1) Re apply the timber treatment annually. (see note on pressure treated buildings in warranty section)
- (2) Visually check for weather damage
- (3) Check and replace if necessary any Silicone sealant if used on your building.
- (4) Check the roofing material for wear
- (5) The doors and windows may require periodical adjustment
- (6) Ensure your building is well ventilated especially during hot weather
- (7) During extremely hot periods humidify your building to prevent the timber from drying out .and shrinking

Recycling and disposal



packaging

1. Pallet and timber widely recycled
2. Cardboard widely recycled
3. Plastic strapping subject to local regulations
4. Plastic sheeting subject to local regulations



Building

1. Timber widely recycled
2. Metal fixings widely recycled
3. Glass widely recycled
4. Roofing felt not currently recycled

Hardware Chart Scale 1:1

Felt Nail
(13mm FN) x150



15

Panel Pin
(16mm PP) x224

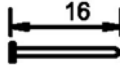

Round head nail
(40mm RH) x55

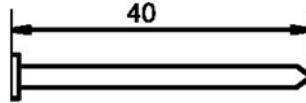

Black
Posi-drive screw
(25mm BLK) x12

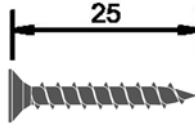

16
Posi-drive screw
(25mm) x94

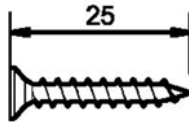

Posi-drive screw
(60mm) x62

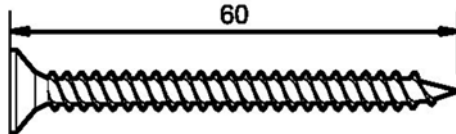

Posi-drive screw
(80mm) x06

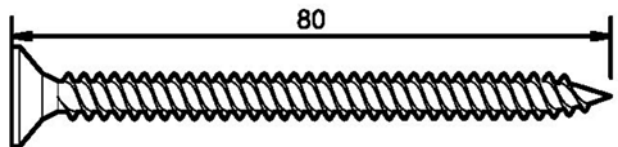

Parts List ...Not to scale

Doors LH RH 	Door Hinge (STH) x10 	Window Insert (WI7) x02 	Casement set (CS-AL) 	Window Panel LH (A1417) x01 	Window Panel RH (A1416) x01 	Floor panels (FP-114) x01
------------------------------	---------------------------------	------------------------------------	---------------------------------	--	--	--------------------------------------

Plain Panel (PP25) x04 	44s framework Square corner post (44s-1930) x01 	Angled door post (78R-2010-45) x02 	44D framework Door step (44D-1360) x01 	Gable Panel; (A1318) x01 	Door barrel bolt (DB) x02 	Turn button (TB) x02
-----------------------------------	--	---	---	-------------------------------------	--------------------------------------	---------------------------------

Gate Latch set (GL) x01 	44s framework Truss block (44s-150) x02 	44s framework Truss (44s-2335) x01 	Front LH Roof panel From inside looking (RP103-LH-F) x01 	Front RH Roof panel From inside looking (RP103-RH-F) x01
------------------------------------	--	---	---	---

Back LH Roof panel From inside looking (RP103-LH-B) x01 	Back RH Roof panel From inside looking (RP103-RH-B) x01 	LH Roof panel (RP104-LH) x01 	RH Roof panel (RP104-RH) x01 	Felt strips (FLT-3.7m) (FLT-2.1m) 	Cover strips (44C-1940) x04
--	--	---	---	--	--

Profiled cover (34C-1990) x02 	Fascia (70FC-1300) x02 (70FC-800) x02 	Diamond (DI) x01 	Glazing (GL268-373) x28 	Beading (8.5B-377) x56 	Beading (8.5B-270) x56
--	--	-----------------------------	------------------------------------	-----------------------------------	-----------------------------------

In more detail.....

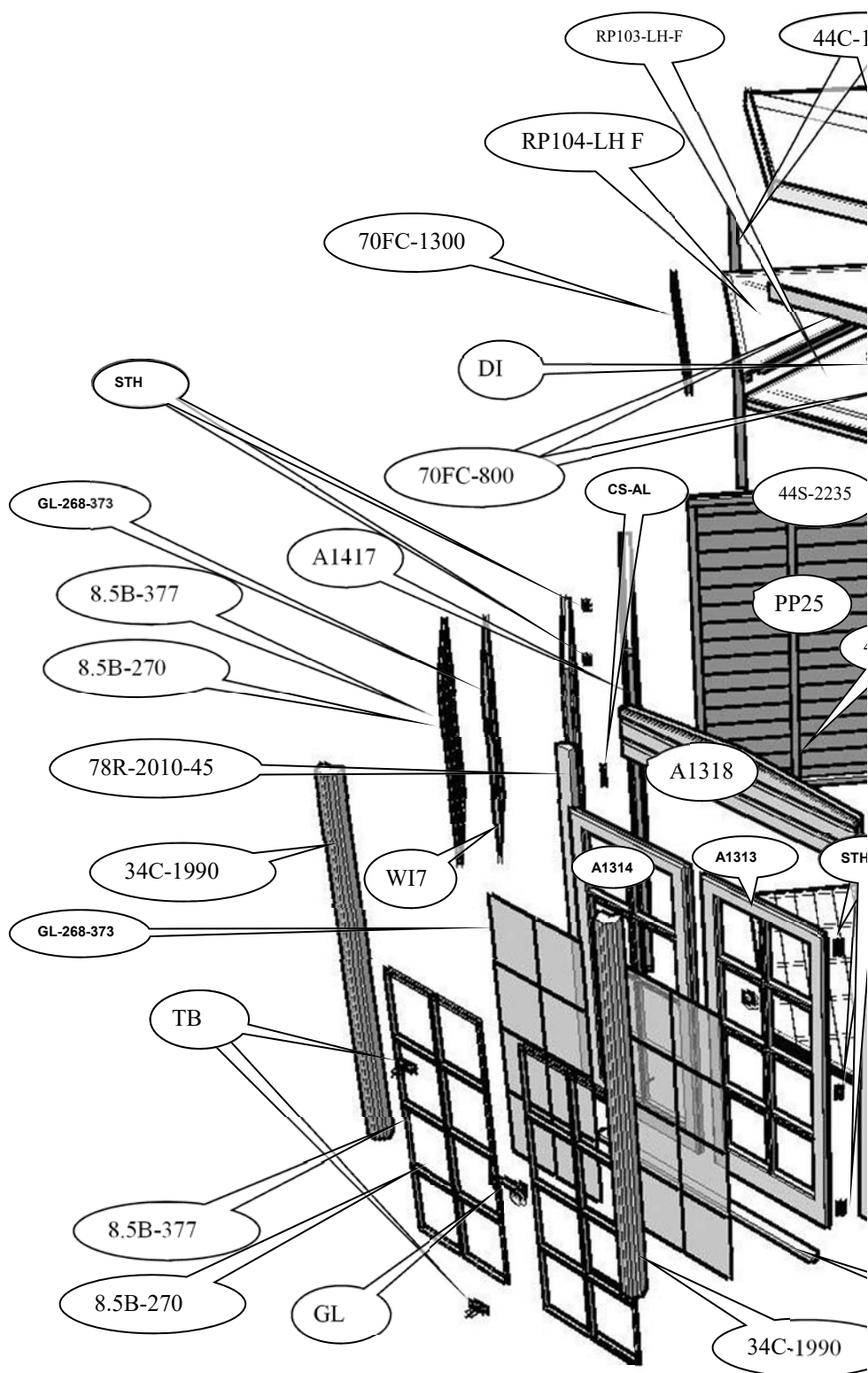

Detailed Technical drawing 1:20

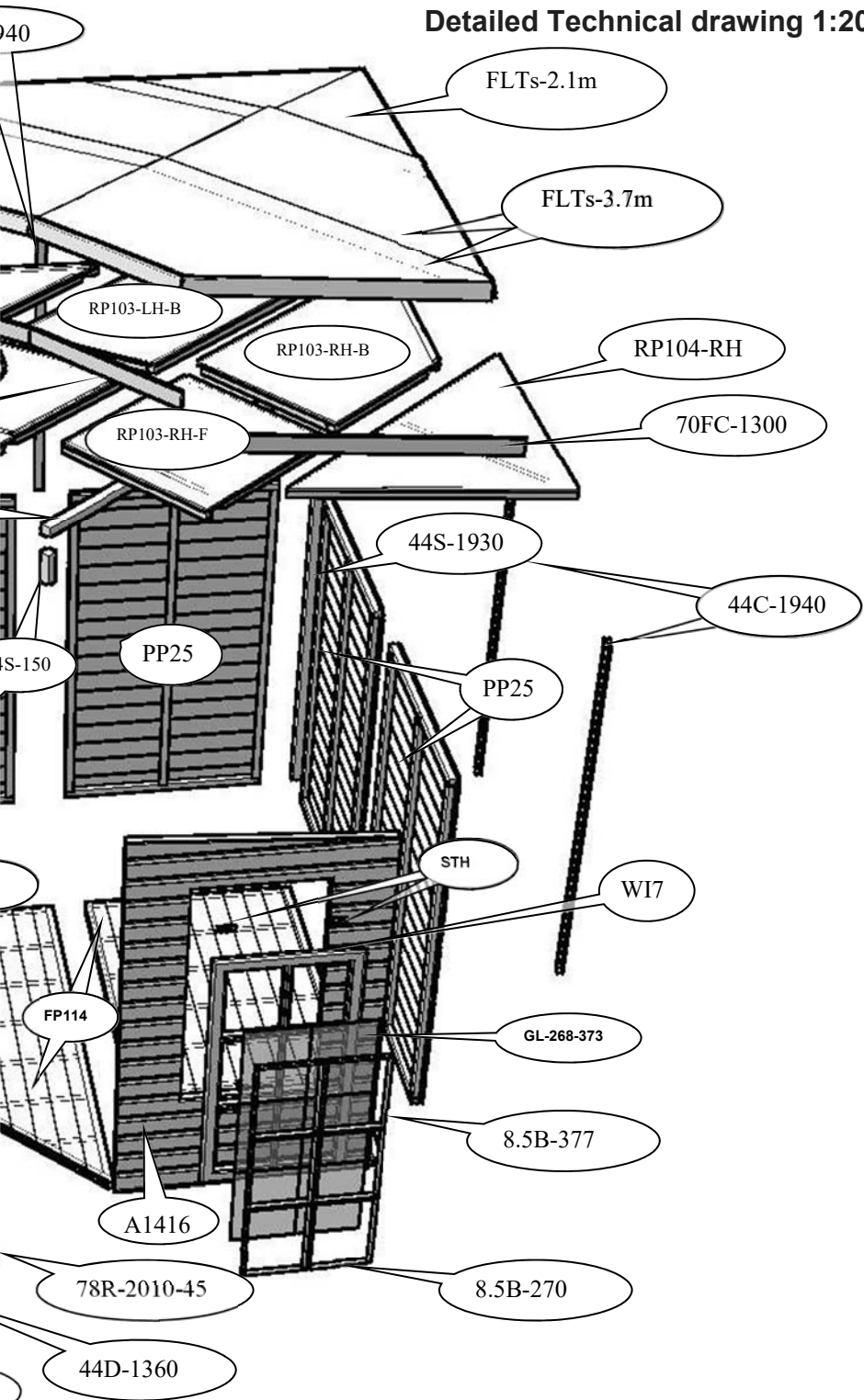

In more detail.....

In more detail.....

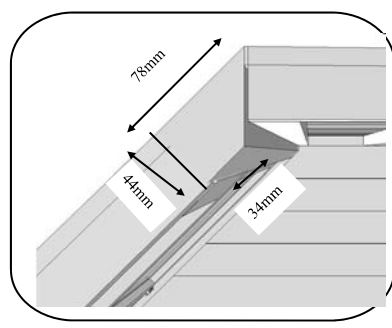

View from al

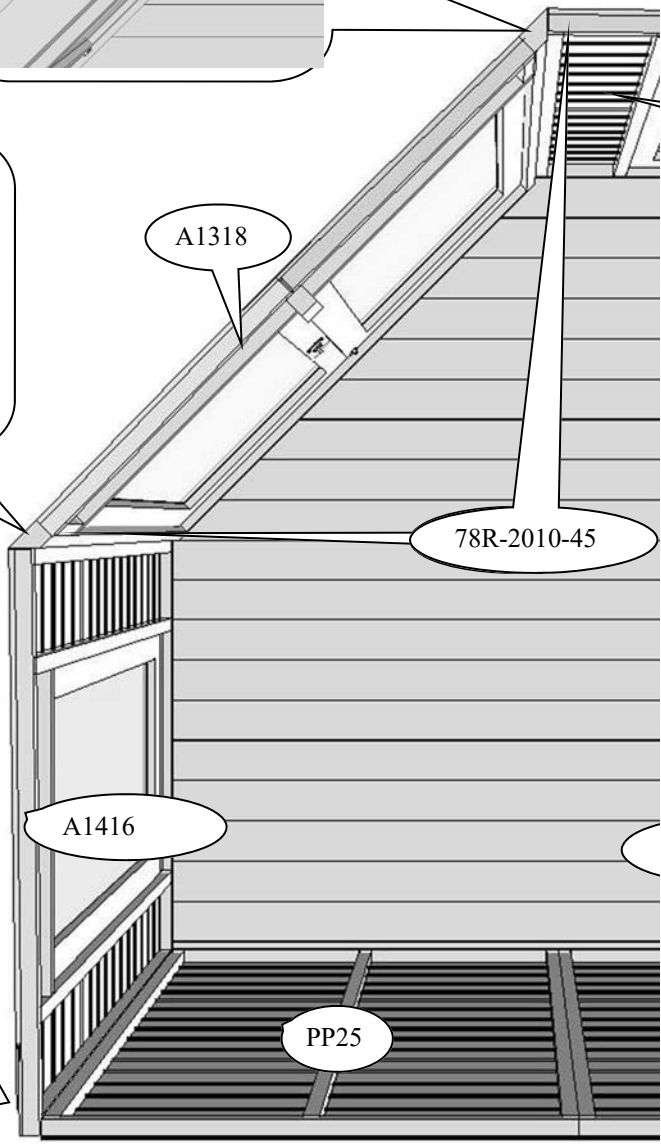
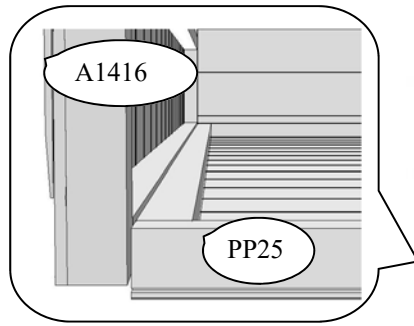
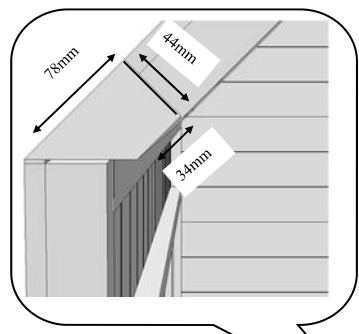

move and enlarged corner details

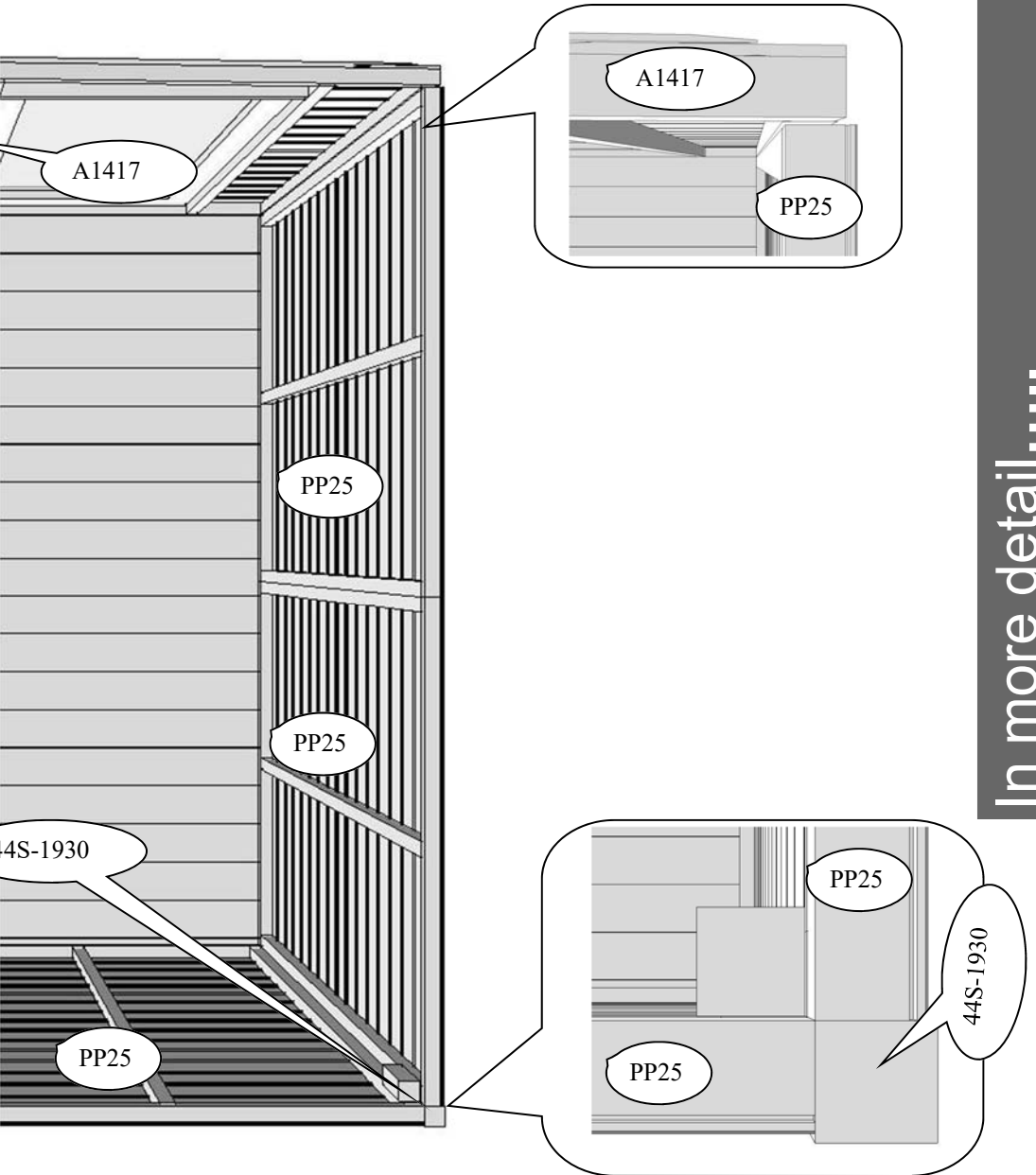

In more detail.....

Things to check before you start

- ✓ Ensure your base is ready– See page 3
- ✓ Check all parts as listed in the parts lists
- ✓ Read the instructions fully before starting work
- ✓ Follow all the health and safety guidelines



6mm

When you see the drill icon

Only ever drill through the first piece of framework which will be a pilot hole for the screw to attach the second piece of framework

The required drill bit size is shown with the icon.

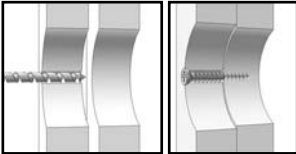

You will need



• Hammer



• Spirit level



• Ladder

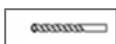

• 1mm, 3mm & 6mm drill bit



• Drill

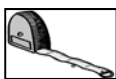

• Tape measure or Ruler



• Sand paper



• Gloves



• Saw



• Pencil



• Goggles



• Chisel



• A helper for some tasks



• Screwdriver



• Sharp knife

Getting Started.....

Assembly

These instructions are for your safety. Please read through them thoroughly before use .
Treat all the parts before assembly –see page 5

01

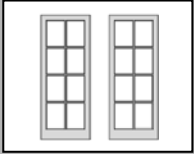

Doors
(A1314 A1313)

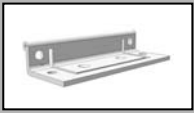

Door hinge
(STH)x06

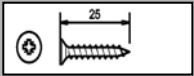

Screw
(25mm)x12

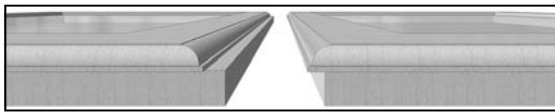
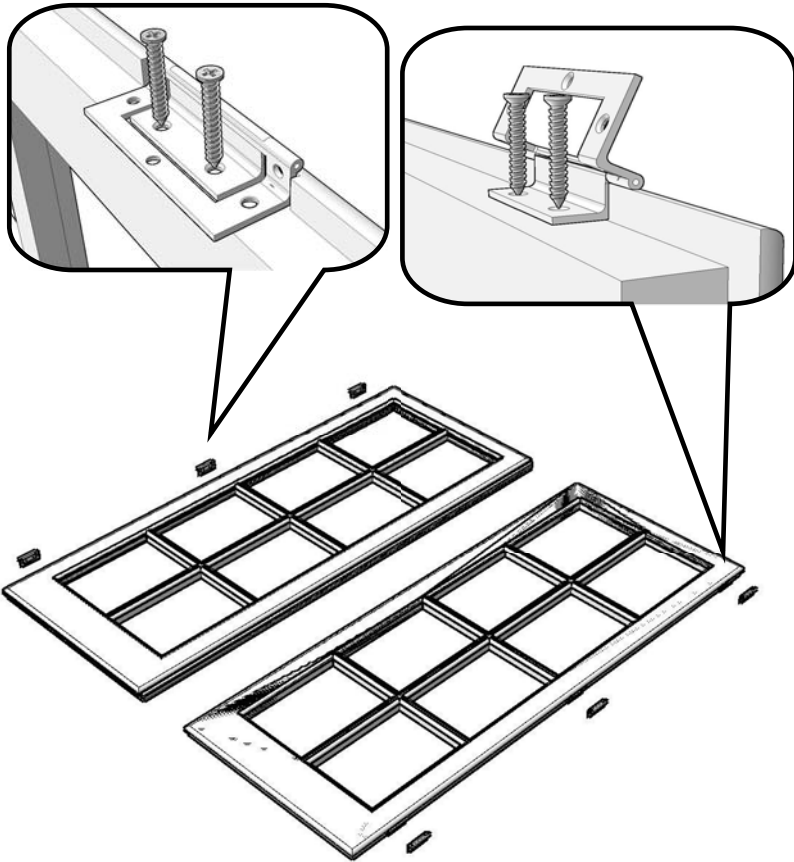

A1314
Secondary door
Bolted

A1313
Primary door
Opening first

View on bottom of doors

GB-IE

Try the window in position in the panel to check that you have it the correct way around. The hinges fit the top of the window.

02



Window insert
(WI7) x02



Hinge
(STH)x04

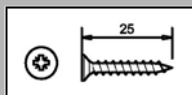

Screw
(25mm)x08

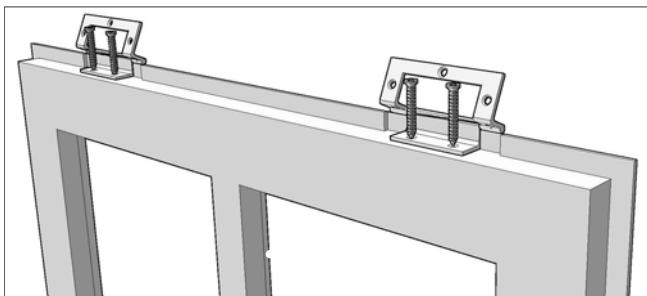
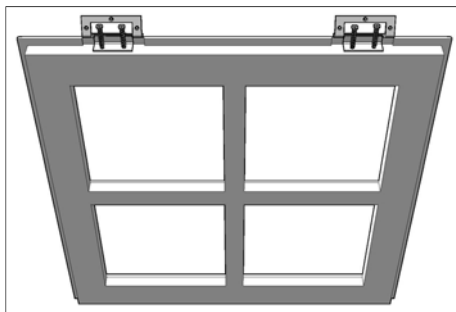
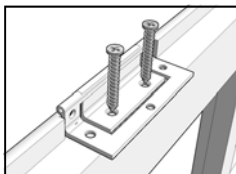

GB-IE

Position the window insert in the aperture and screw the inner screw holes that are just visible first. Open the window and insert the remaining screws.

03

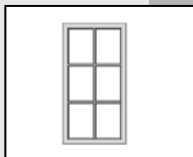

STEP 2
x02

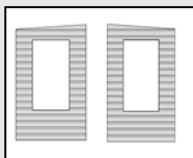

Window panels
(A1416 & A1417)

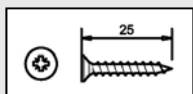

Screw
(25mm)x20

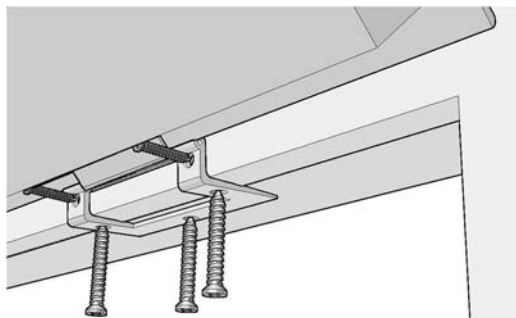
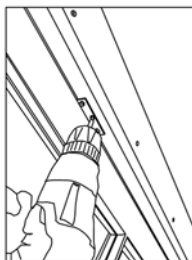

GB-IE

Casement stay and pins must fit together loosely.
Fix the casement stay to the window insert first.
Then mark and fix the pins .

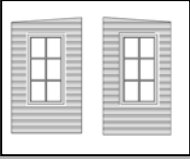

Step 3
x02

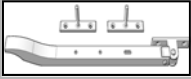

Casement set
(CS-AL) x01

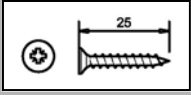

Screw
(25mm)x12

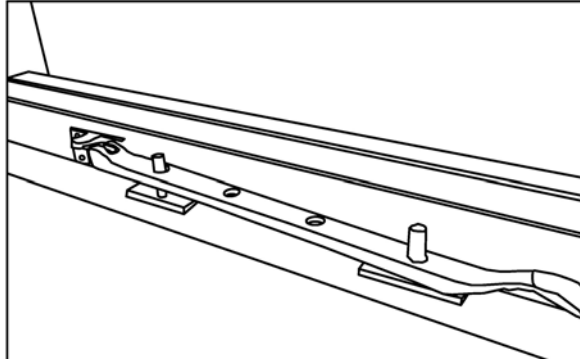

GB-IE

Stand both floor panels on edge, drill one floor panel and screw them together.
Lay your floors in position on your base.

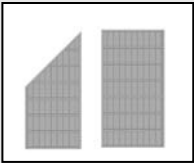

Floor
(FP114) x01 pair

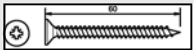

Screw
(60mm)x04

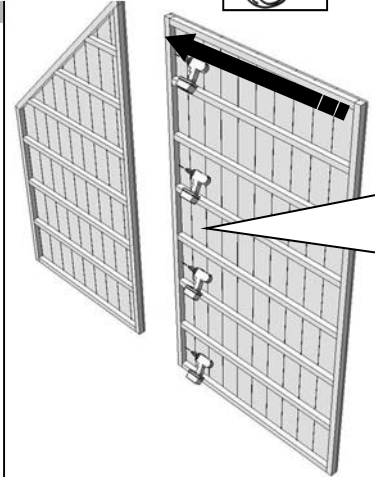
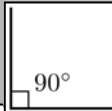

 If using a drill or electric screwdriver carefully but firmly push the opposite end to the screwdriver bit into the screw head and keep the pressure on to prevent the screwdriver spinning in the screw

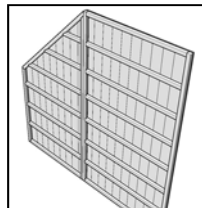

GB-IE

Attach the plain panel "PP25" to the post "44S-1930" so the post is flush with the framework and the face of the cladding. At the bottom the post is flush with the framework.

06



Plain panel (PP25 x01)

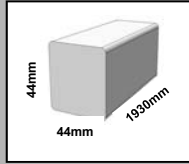

Corner post (44S-1930) x01

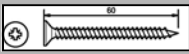

Screw (60mm)x03

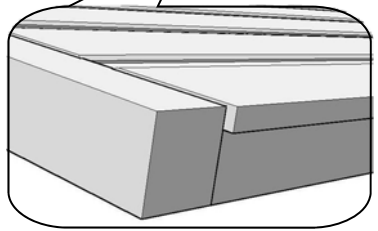
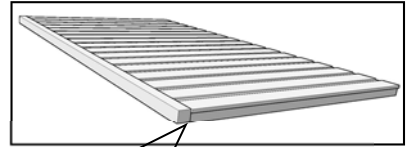
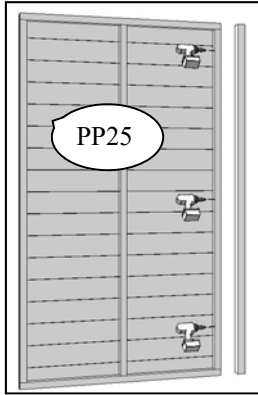
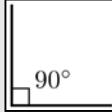

GB-IE

Place the panel from step 3 in the corner. Position & fix another "PP25" plain panel against the post as above so the post overhangs the floor and is not seen from inside the building.

07

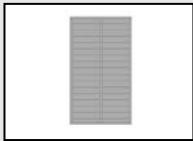
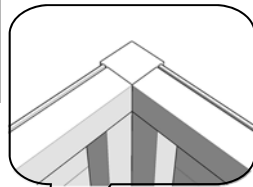
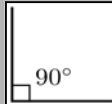

Plain panel (PP25 x01)

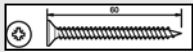

Screw (60mm)x03

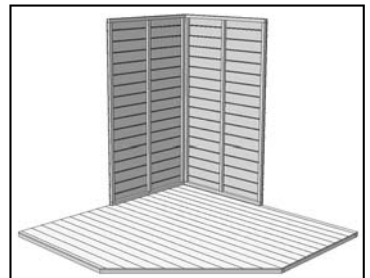
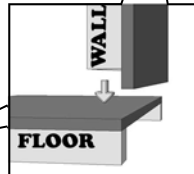
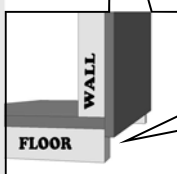
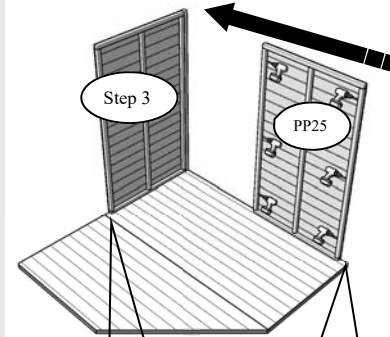

GB-IE

Add two more plain panels "PP25".
This will leave a 34mm step on both corners to the edge of the floor.

08

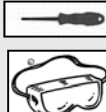
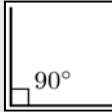

Plain panel
(PP25 x02)

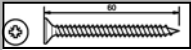

Screw
(60mm)x06

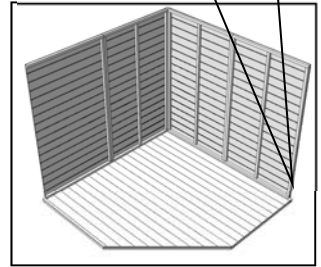
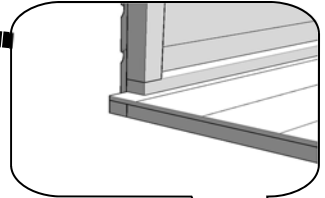
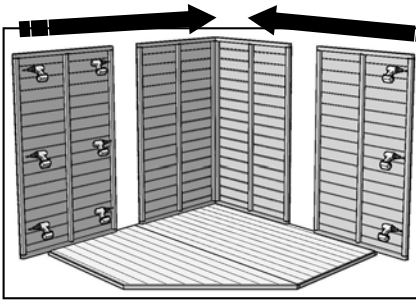

GB-IE

Position and fix the two window panels, the panels will be flush with the corners.
Drill 3 holes per window panel to fix the step 10 "78R-2010-45" angled posts

09

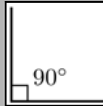

Window panel
(WP7) x LH & RH

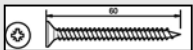

Screw
(60mm)x06

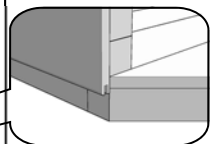
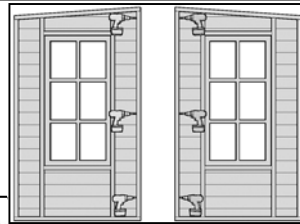
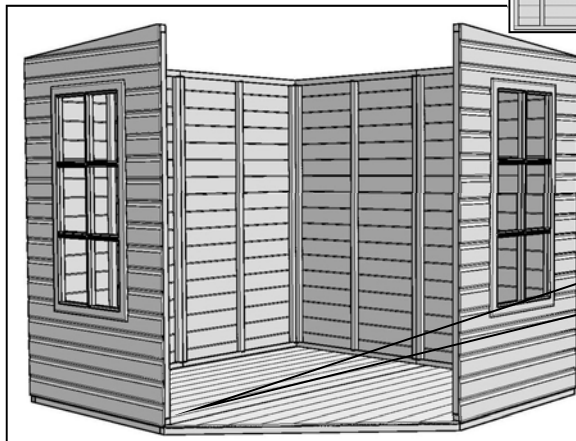

Place one Angled door post '78R-2010' at the edge of one window panel. The wider part of the post should be flush to the front of the window panel and the sawn edge should rest against the window panel. The post should rest on the floor, but will overhang slightly. Drill/screw into position through the panel framework into the post using 3x 60 mm screws. Repeat at other side.

10

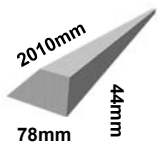

Angled door post
(78R-2010-45) x02

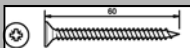

Screw
(60mm)x06

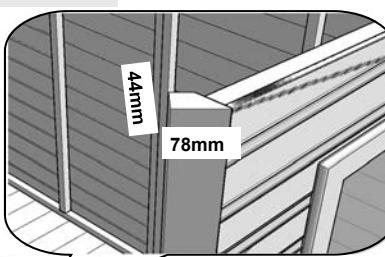
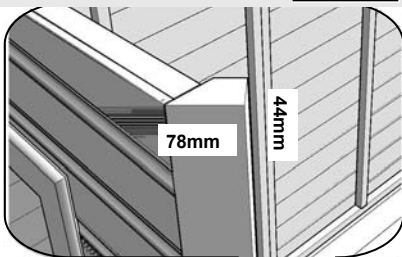
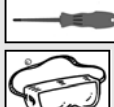
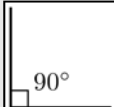

**SEE PAGES
10&11**

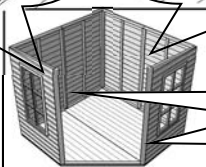

**MUST BE
1360mm
between posts**

- GB-IE Pre drill the door step "44D-1360" and the gable "A1318" before positioning. Also fix a truss block to the gable with 2 x 80mm screws. Fix the door step "44D-1360" on the floor between the posts from the previous step with 60mm screws. It should be central to the floor and it may be necessary to adjust the position wall panels to line up everything correctly. Fix the gable panel "GP05" level with the top of the posts with 60mm screws. Screw all the panels to the floor with 2 60mm screws each.

11

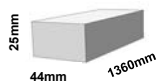

Door step
(44D-1360)x01



Gable Panel
(A1318)x01



Screws
(60mm)x19
(80mm)x2

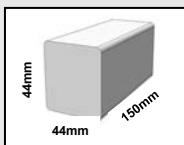

Truss block
(44S-150)x01

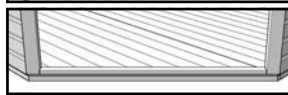
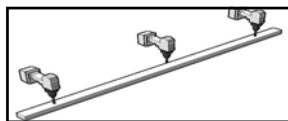
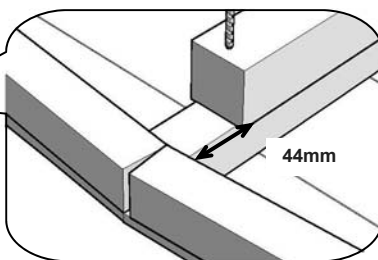
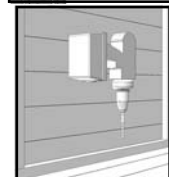
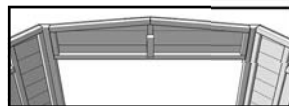
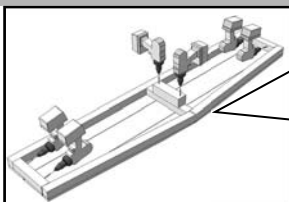
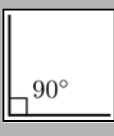

18

GB-IE Fix both doors leaving an even gap top and bottom with 1 x 25mm screw at first to the angled posts at each of the hinges
Adjust the door if necessary and fit the remaining screws

12

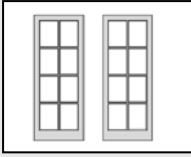

Doors
STEP1

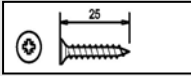

Screw
(25mm)x30

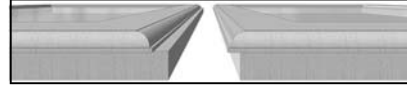
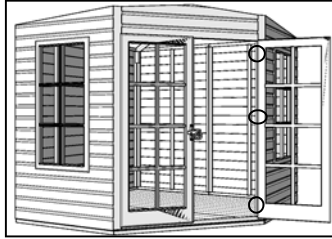

Secondary door
Bolted

Primary door
Opening first

View on bottom of doors

GB-IE Fix a bolt at the top and bottom of the secondary door, mark where the bolt strikes the frame and drill an 8mm hole to take the bolt.

13



Door barrel bolt
(DB)x02

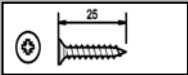

Screw
(25mm)x12

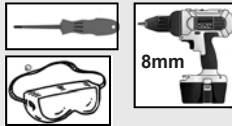

8mm

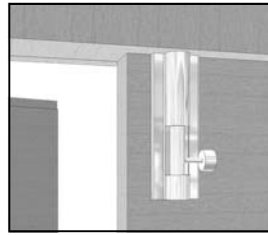
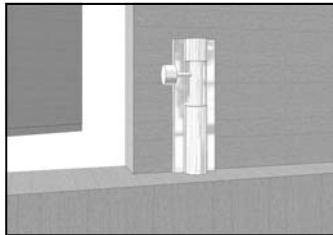

GB-IE Fix a turn button to the top and bottom of the secondary door so they hold the primary door shut. This is to help with natural timber movement during different weather conditions. Failure to fit these turn buttons may result in the doors bowing.

14



Black Turn button
(TB)x02

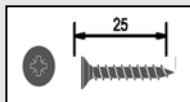

Black Screw
(25mm)x2

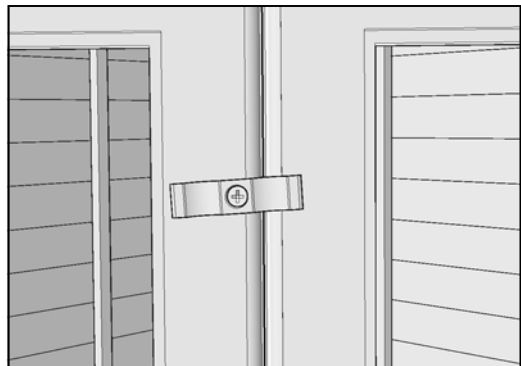

Position the "black ring handle B-RH" on the outside over the door framework, mark the screw holes as shown, drill the middle hole only for the "wooden knob WKB", attach the wooden knob on the inside of the door first with the 45mm flat head screw and then attach the ring handle on the outside of the door over the flat head screw.



Gate latch set
(GL) x01

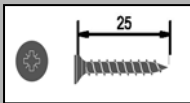

Black Screw
(25mm)x10



8mm

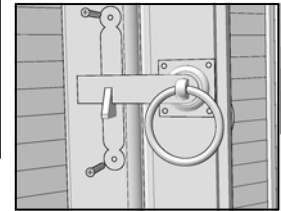
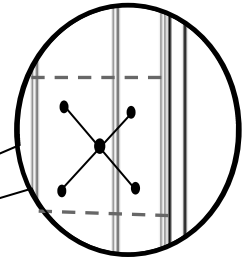
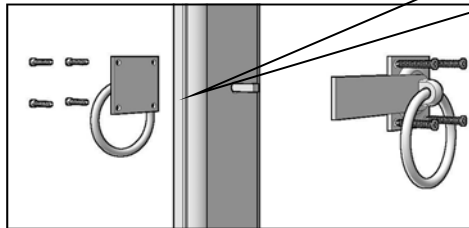

On the inside back corner fit a truss block 78mm down from the top with 2x 80 mm screws.
Position the truss on this block and the one fitted in step 8 to the gable
Pre drill the truss and fix with 2x80mm screws.
The truss will sit 34mm below the top of the panels (for the roof frame work to sit on top).

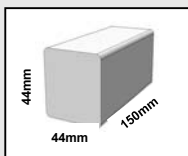

Truss block
(44S-150)x01

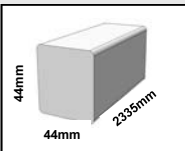

Truss
(44S-2335)x01

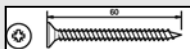

Screw
(80mm) x04



6mm

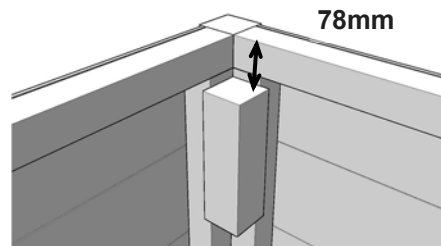

78mm

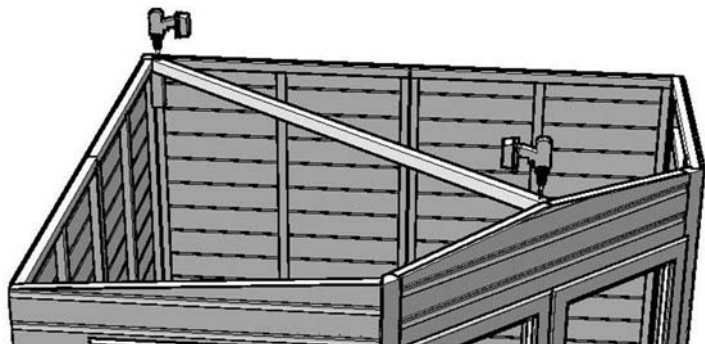

When joining the roof panels "RP103" together ensure the chamfered corners are positioned correctly.



Front LH Roof panel (RP103-LH-F) x01



Front RH Roof panel (RP103-RH-F) x01



Back LH Roof panel (RP103-LH-B) x01

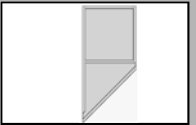

Back RH Roof panel (RP103-RH-B) x01

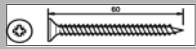

Screw



6mm

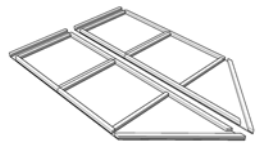
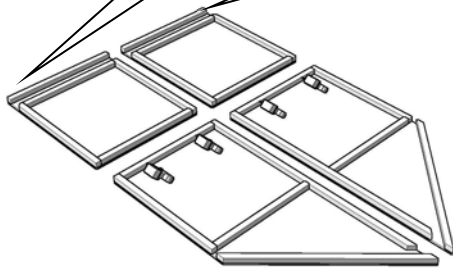
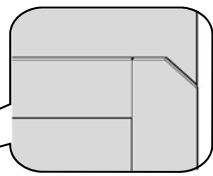
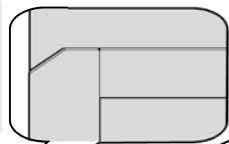

Pre drill the roof panels only ready for fixing together when in position on the building.

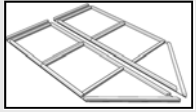

Assembly step



6mm



Roof Panel (RP104 RH)x01



Roof panel (RP104-LH)x01

Front

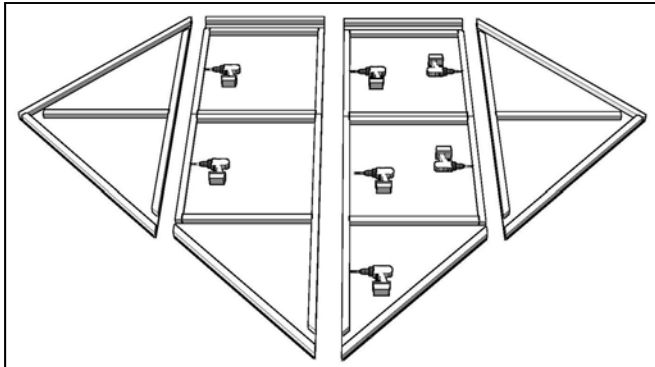

19

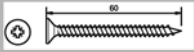
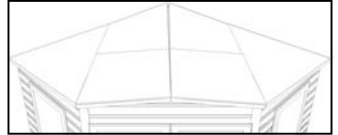
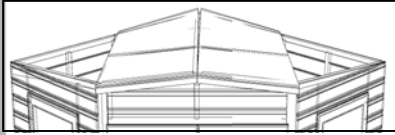
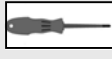
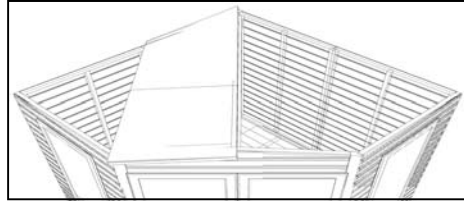

Screw
(60mm)x11

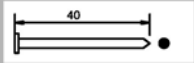

Nail
(40mm) x16

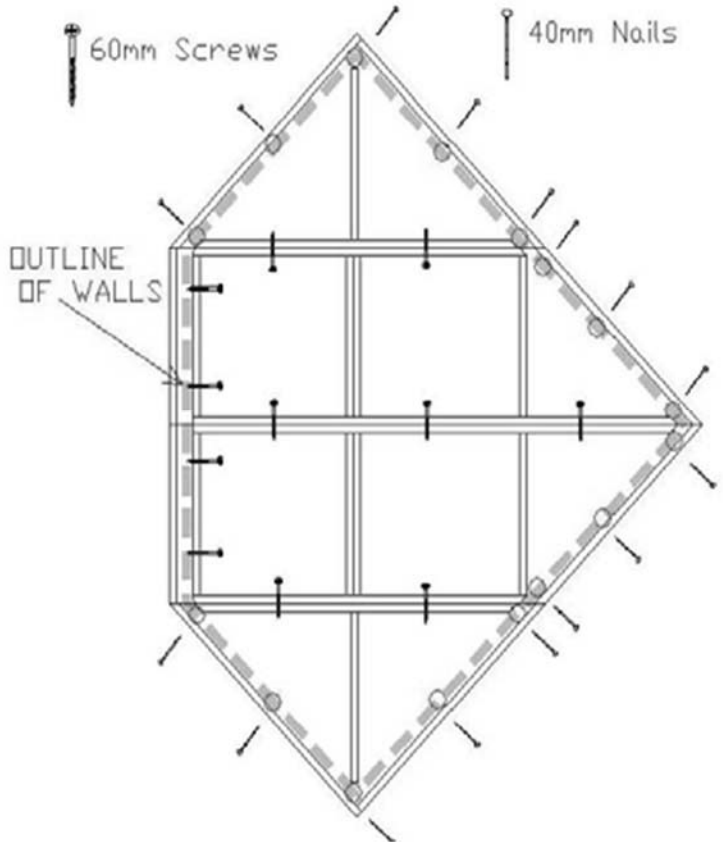

Carefully screw the panels together using the pre drilled holes and also use 3 screws to fix to the gable.
Nail through the roof panels into the top of the walls.

GB-

Position all the felt, starting from the back, without fixing first to ensure you have an even overlap and at least 50mm to fold over the roof edgings and trim later .
Once you are happy with the positioning nail on top of the felt near the edge approximately 75mm apart.
Fold down the excess over the roof edgings fix as above and trim off the excess felt level with the bottom of the roof edging.

20

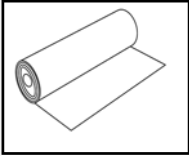

Felt strips
(FLT-3.7m) x02
(FLT-2.1m) x01

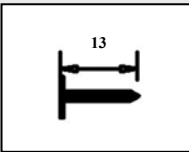

Felt Nail
(13mm) x150

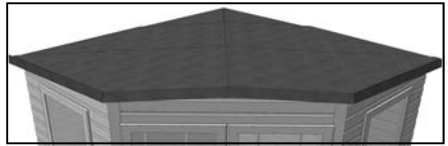
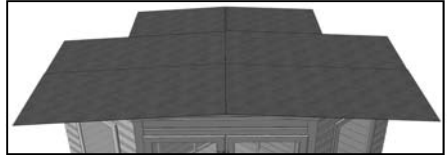
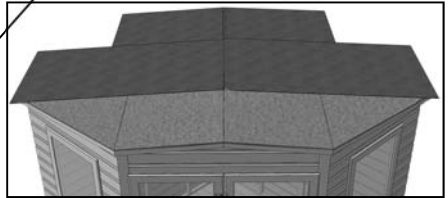
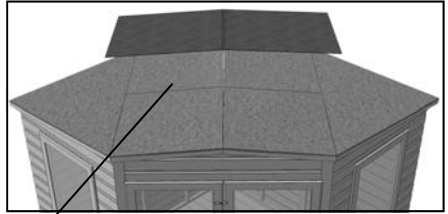

Reverse view

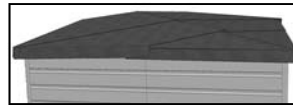

Reverse view

GB-IE

Fit cover strips at each corner with 4 nails each

21

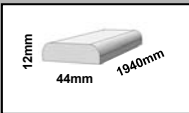

Cover strip
(44C-1190) x04



Cover strip
(34C-1990) x02

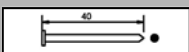

Nail
(40mm) x24

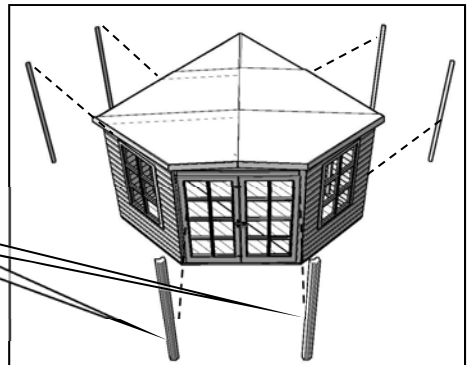

34C-1990

GB-IE

Fix the fascia's to the window panel first and then the gable with 3 nails each.
Fix the diamond over the fascia join with 3 nails

22

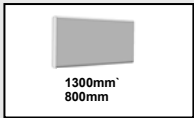

1300mm
800mm

Fascia
(70FC-1300) x02
(70FC-800) x02



Diamond
(D1) x01

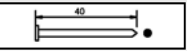

Nail
(40mm) x15

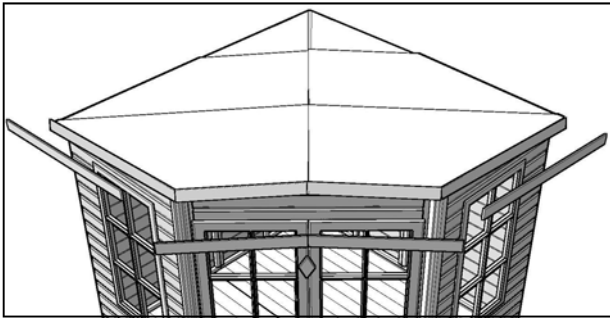
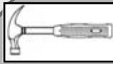

GB-IE

Remove the protective film from both sides of the glazing material before fitting.
Nail the beading at approximately 100mm spacing

Danger of cutting We advise you that a helper should hold the glass in position
whilst you nail the beading. Wear gloves, suitable clothing and shoes,



23

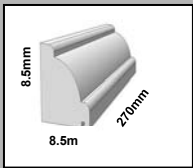

8.5mm
270mm
8.5mm

Beading
(8.5B-270)X56

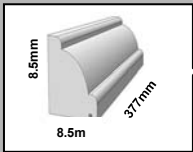

8.5mm
377mm
8.5mm

Beading
(8.5B-377)X56

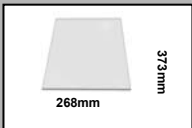

373mm
268mm

Glazing
((GL-268-373)) x28

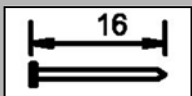

16

Panel pin
(PP 16mm) x224

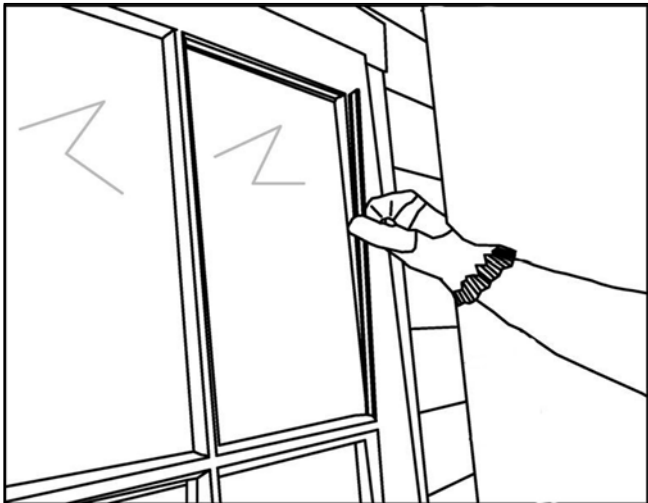
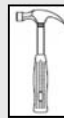

Glass
Danger of cutting