

ASSEMBLY INSTRUCTIONS

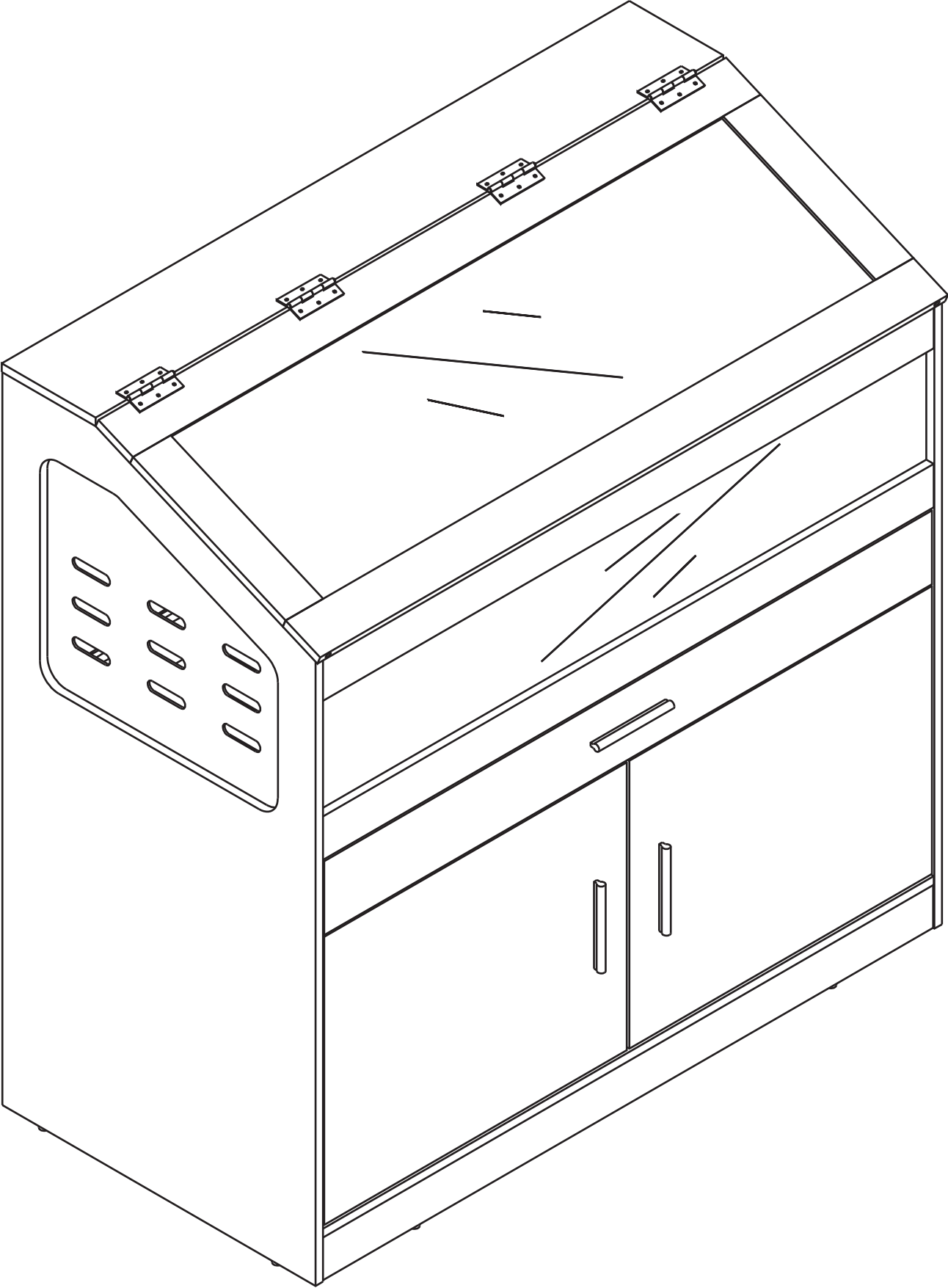

HOPE YOU HAVE A PERFECT SHOPPING EXPERIENCE!

Our product is designed with excellence crafted from premium materials, and exhibits a unique sense of style. Every detail has been thoughtfully considered to bring both elegance and functionality to your space.

Whether in the office or at home, our product offers long-lasting performance and versatile use. We believe it will enhance your environment and make your daily tasks easier.

If you encounter any issues or have questions, please don't hesitate to contact our dedicated customer service team. We are always here to assist and ensure your satisfaction.



1

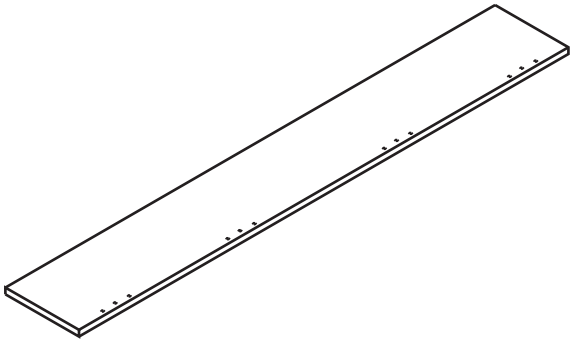

2

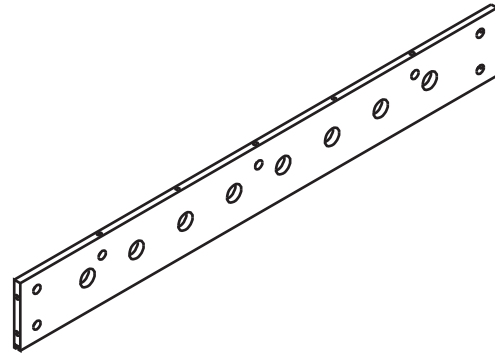

3

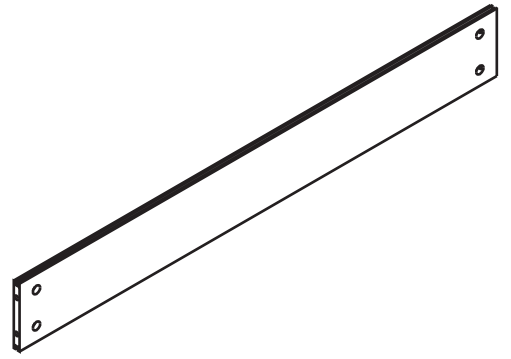

4

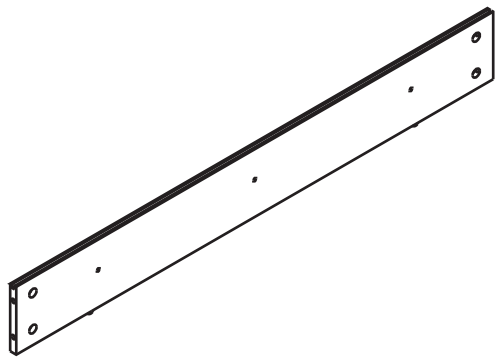

5

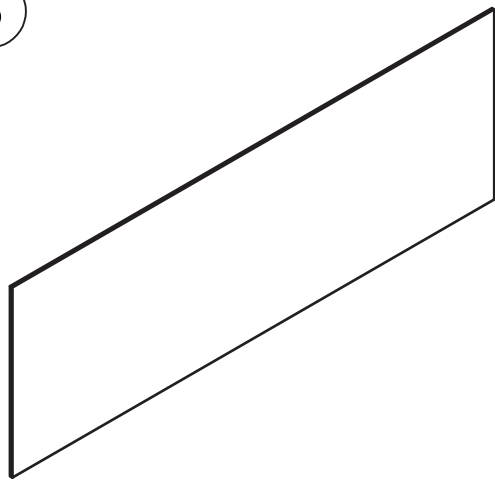

x 2

6

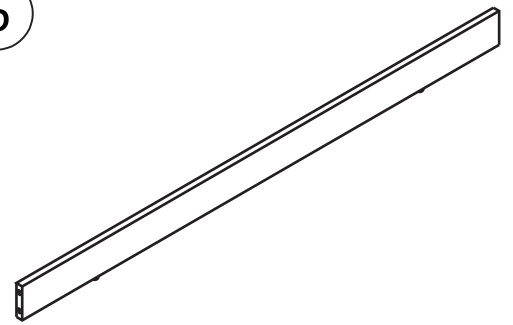

7

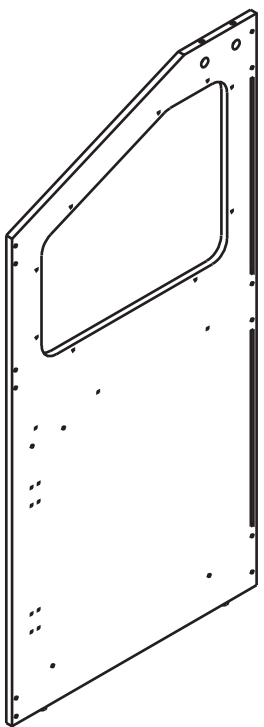

8

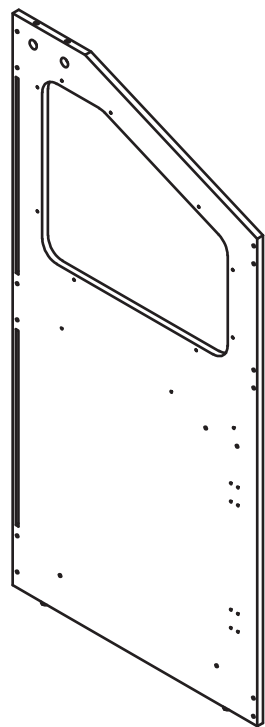

9

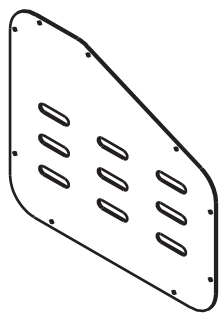

x 2

10

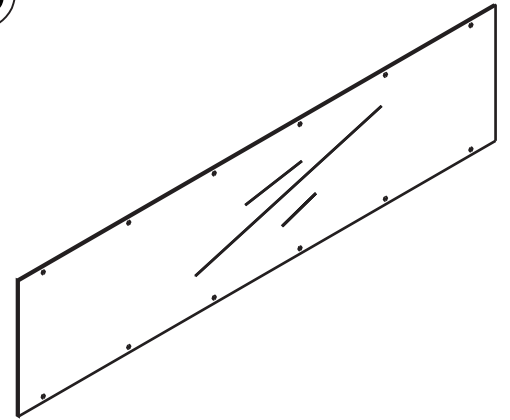

11

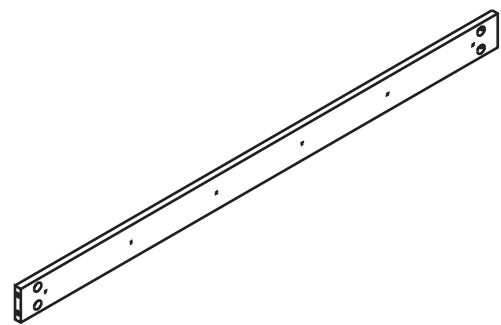

x 2

12

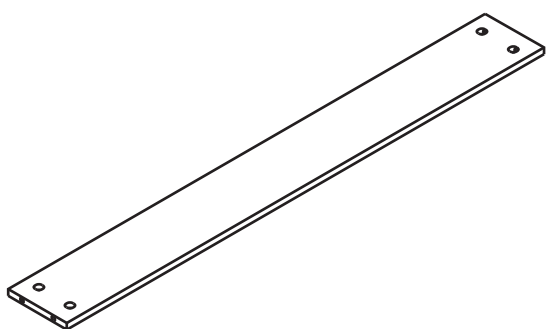

13

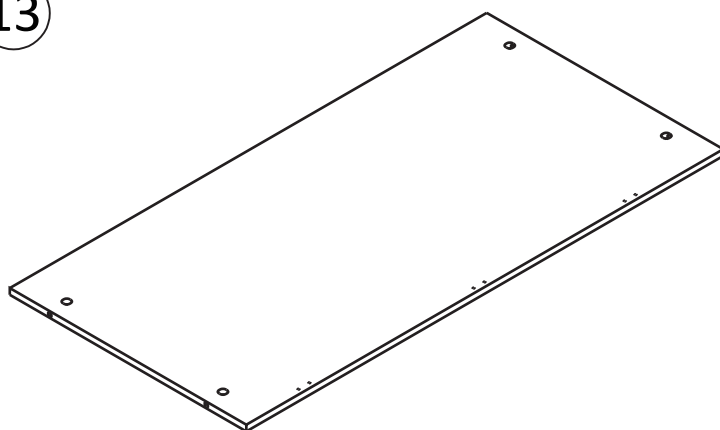



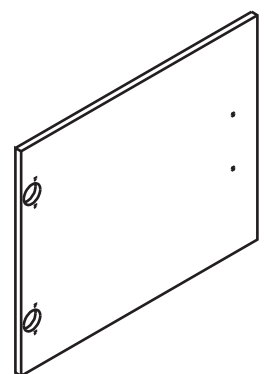



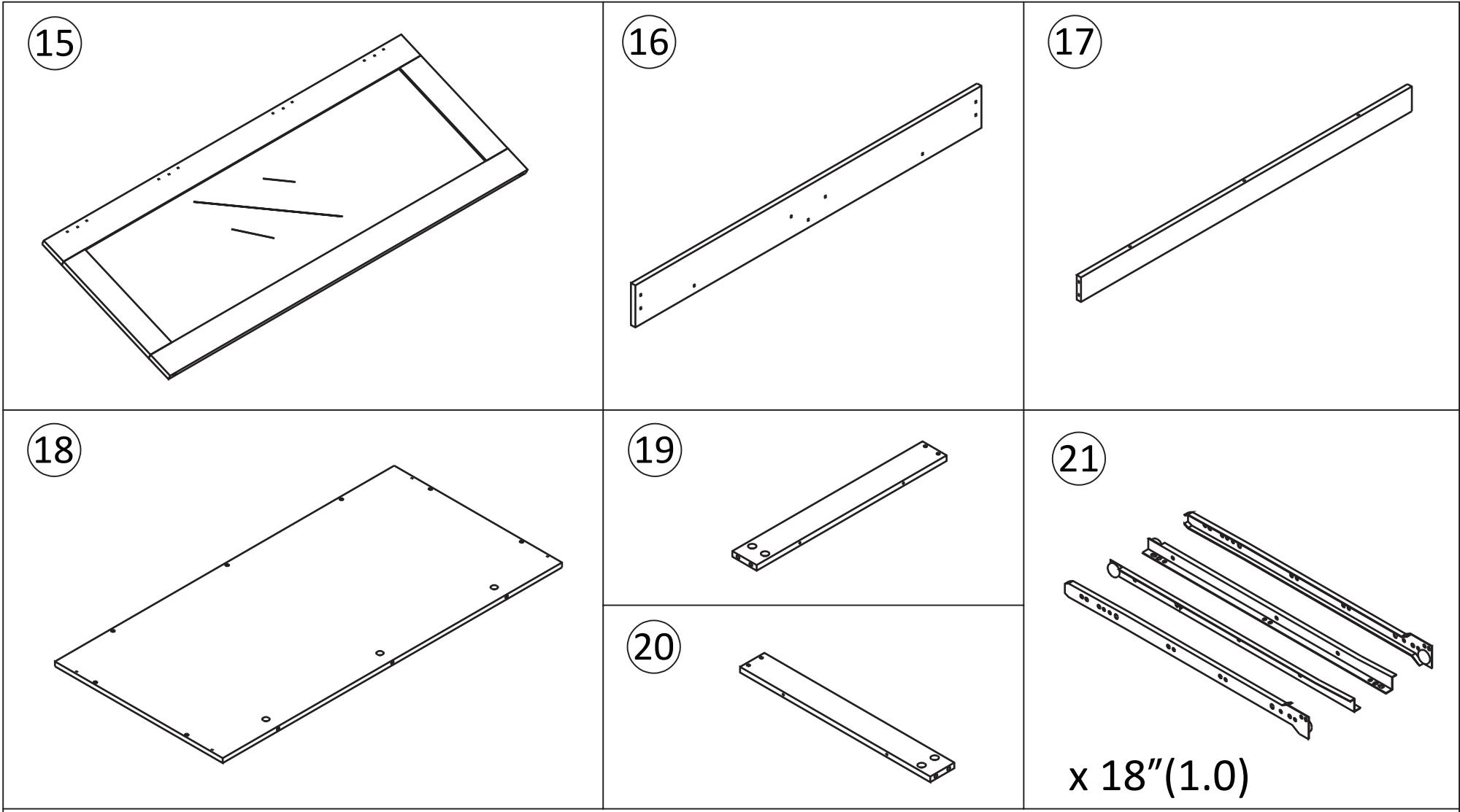

14

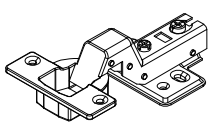
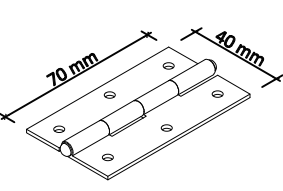
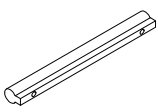

x 2

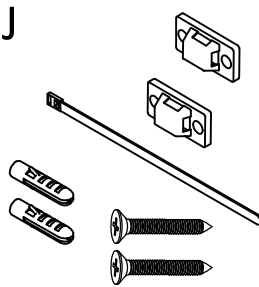
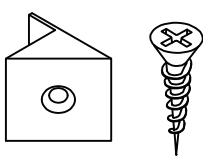
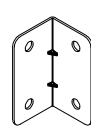

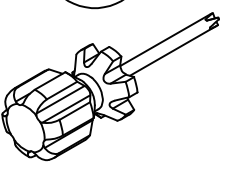
<p>A M5x42</p>  <p>46 PCS</p>	<p>B Ø15x10</p>  <p>46 PCS</p>	<p>C M5x40</p>  <p>14 PCS</p>	<p>D Ø6x40</p>  <p>2 PCS</p>	<p>E M3.5x12</p>  <p>104 PCS</p>	<p>F DW</p>  <p>4 PCS</p>
<p>G 70x40</p>  <p>4 PCS</p>	<p>H 220-96</p>  <p>3 PCS</p>	<p>I M4x15</p>  <p>6 PCS</p>	<p>J</p>  <p>2 SET</p>	<p>K M3.5x14</p>  <p>8 SETS</p>	<p>L 38x20x25</p>  <p>3 PCS</p>
  <p>1 PCS</p>					

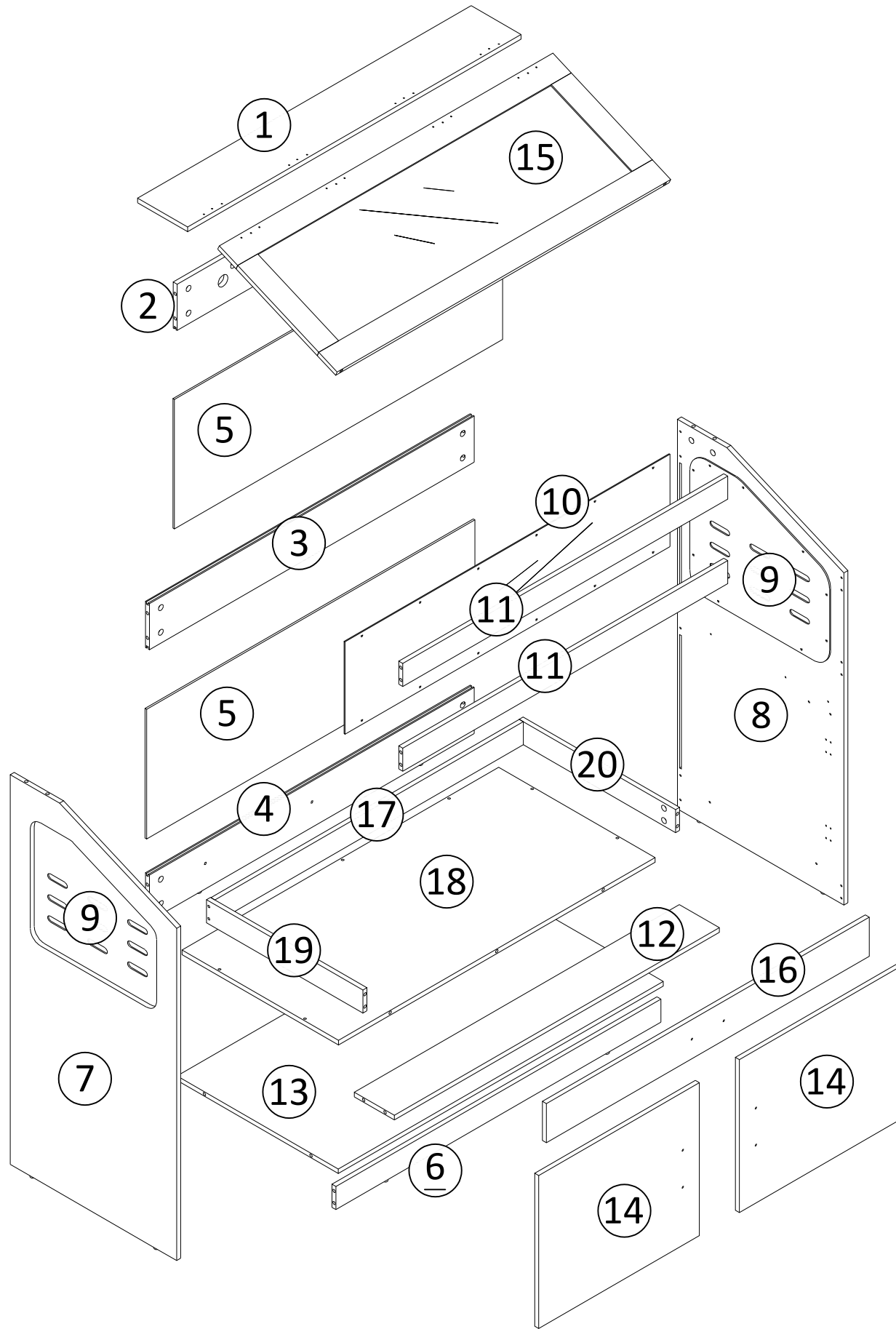

Cam Lock Fastening System

This Cam Lock Fastening System will be used throughout the assembly process

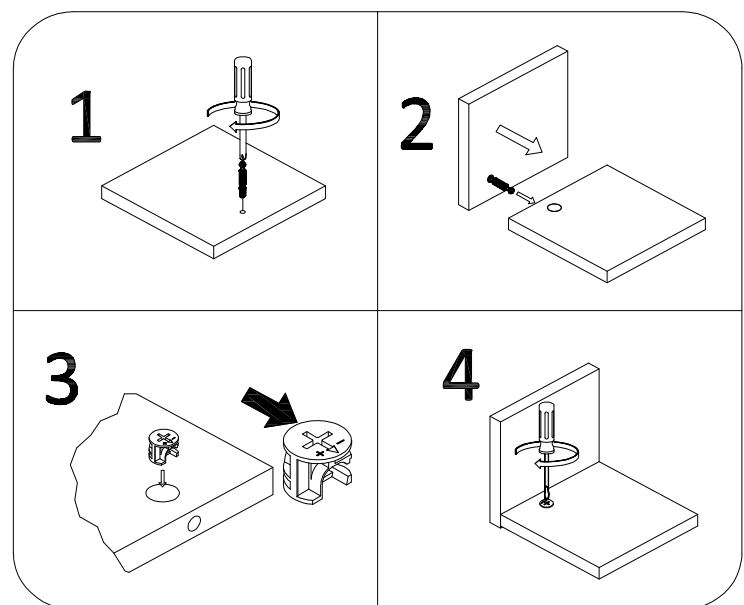
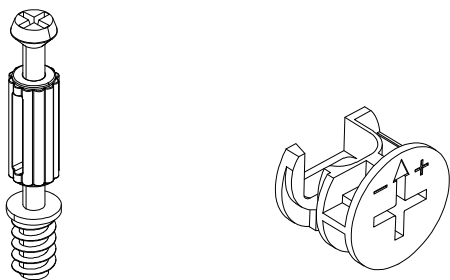

1

Please remove the film from Part 9

When installing Part 9, do not overtighten the screws to prevent cracking.

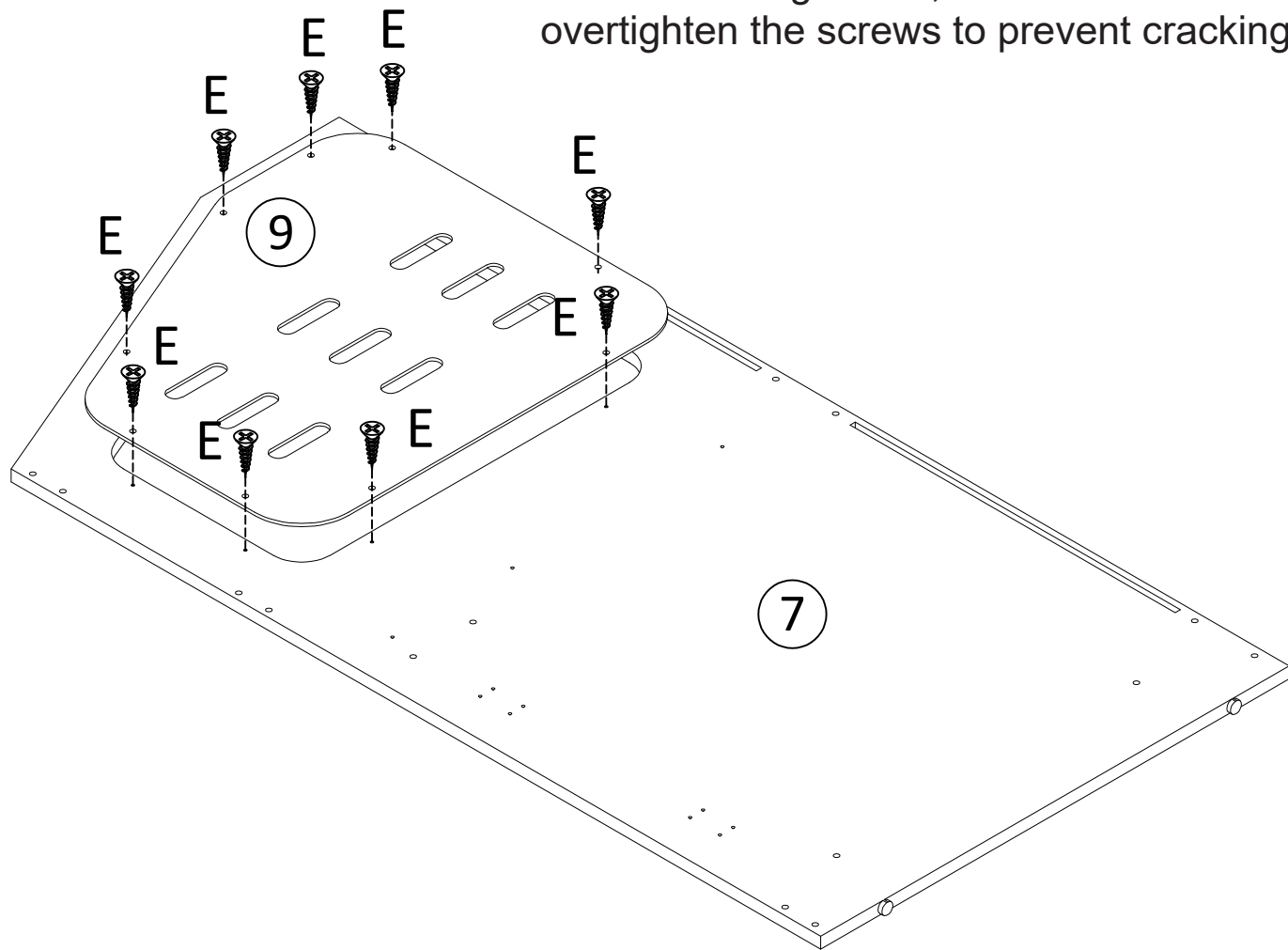

A M5x42



16 PCS

E M3.5x12



12 PCS

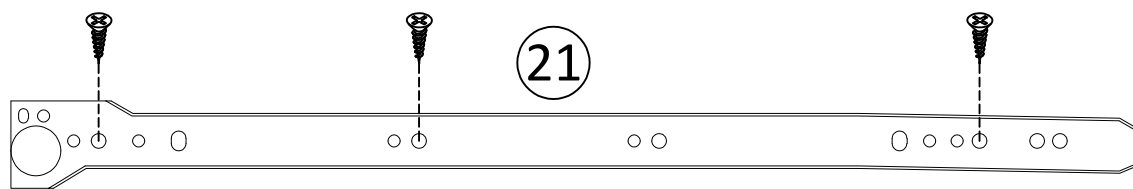

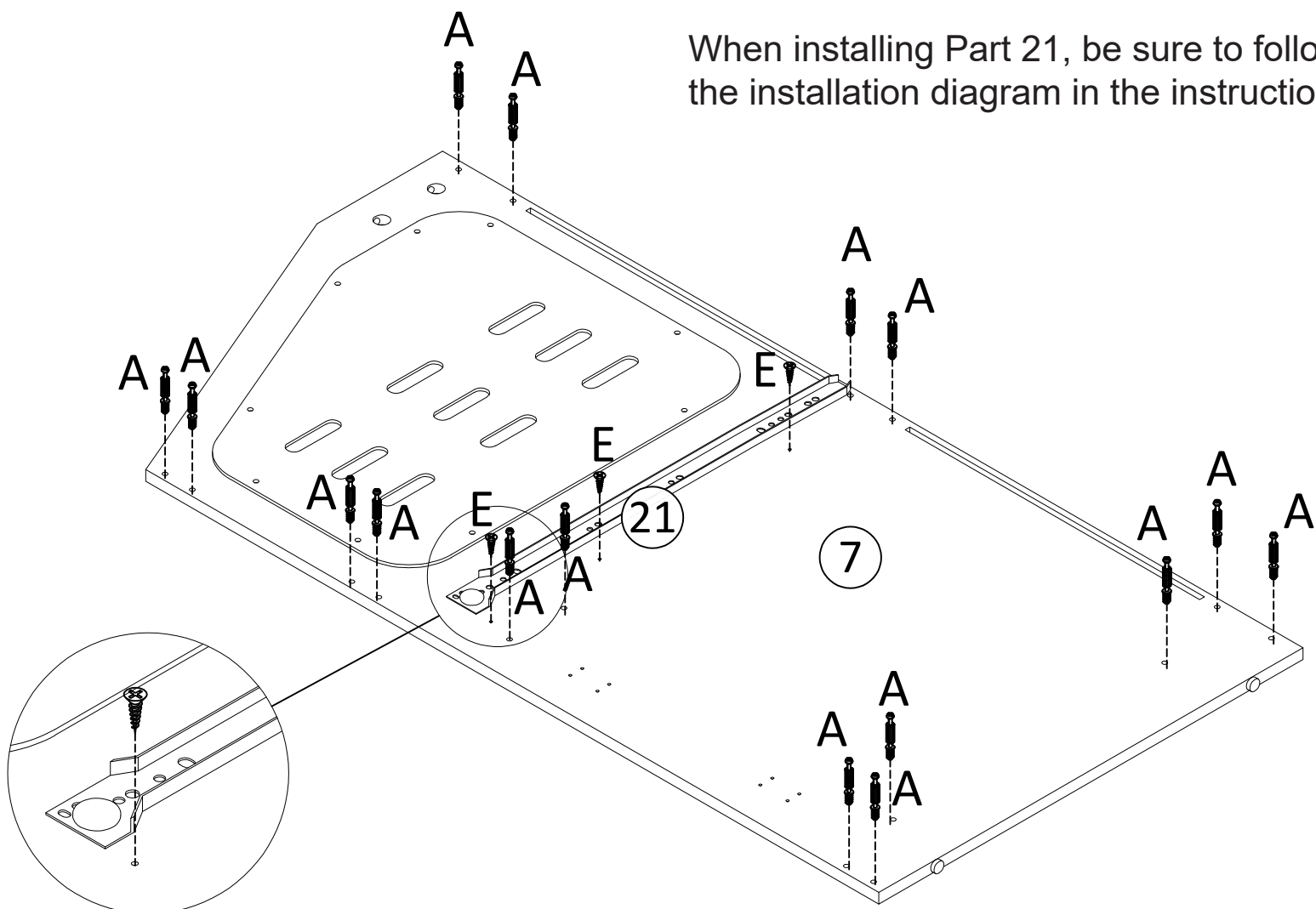

When installing Part 21, be sure to follow the installation diagram in the instructions.

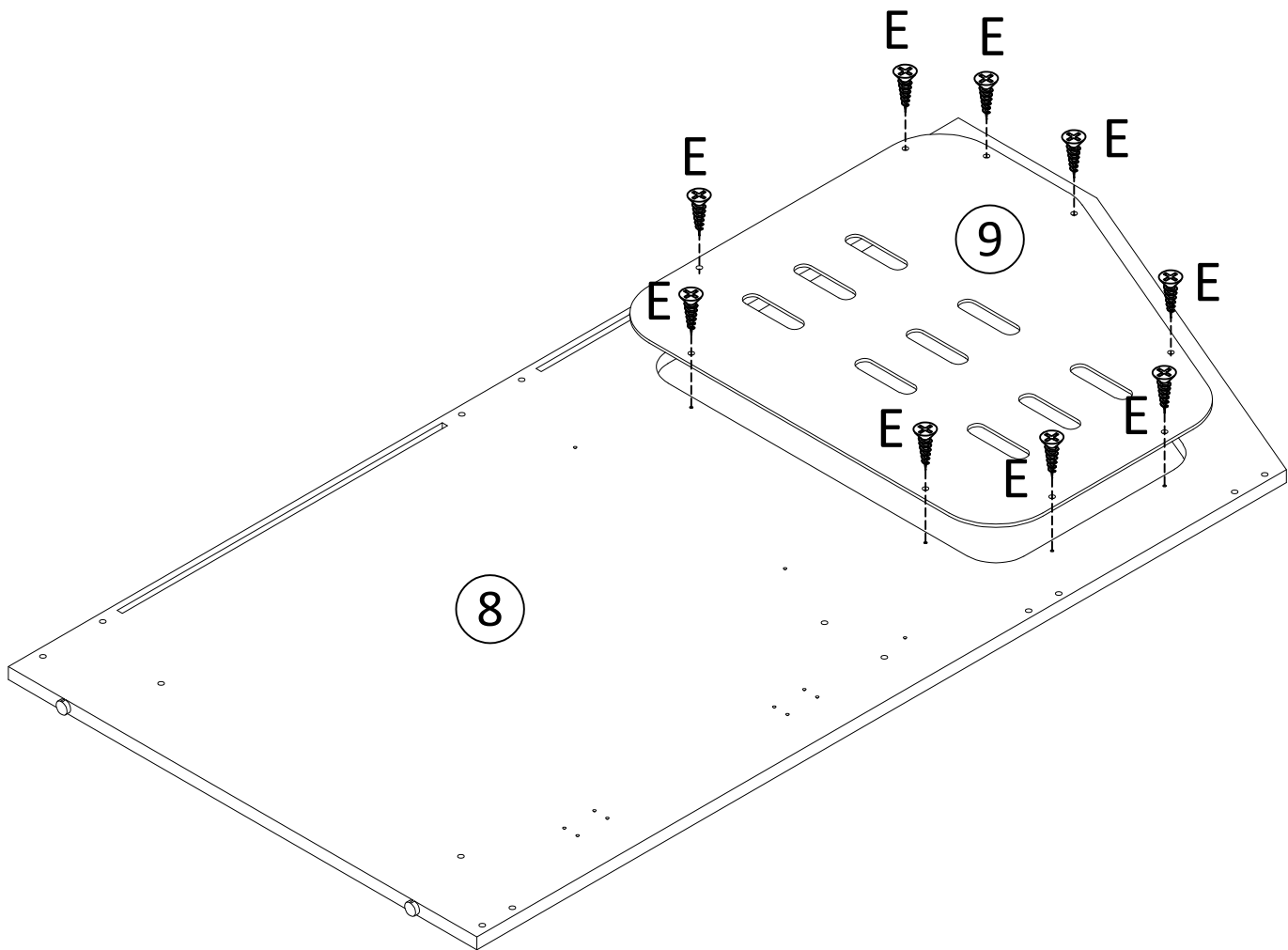

2

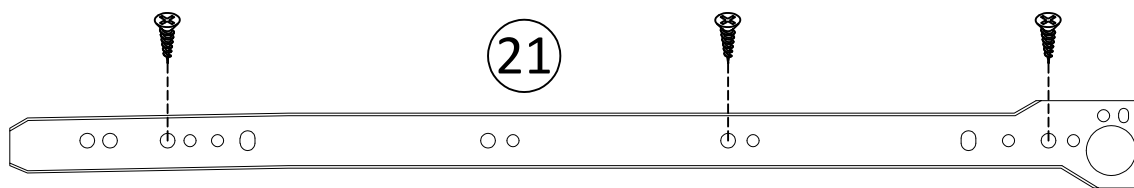

- A M5x42

16 PCS
- E M3.5x12

12 PCS

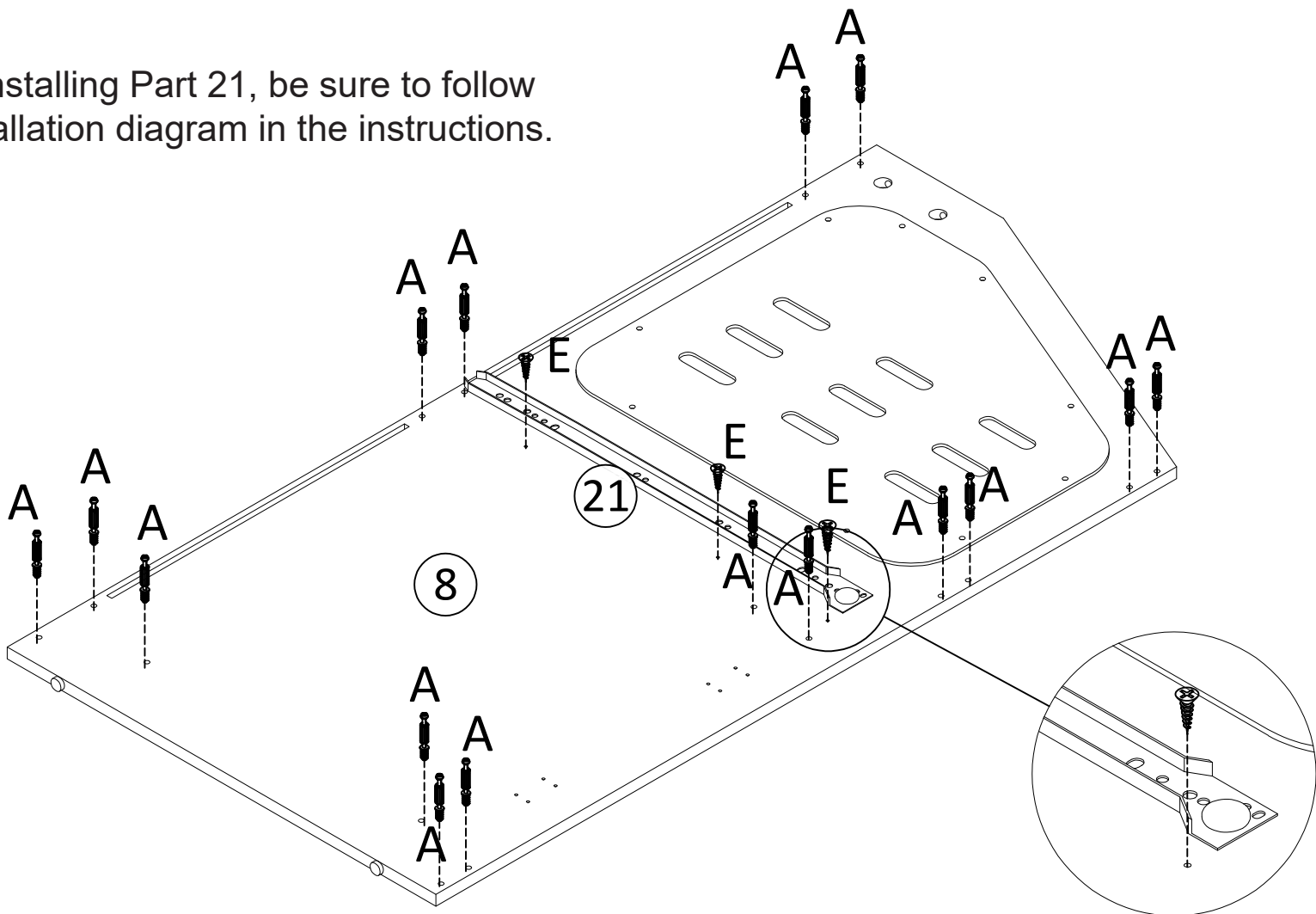

When installing Part 21, be sure to follow the installation diagram in the instructions.



3

B Ø15x10



4 PCS

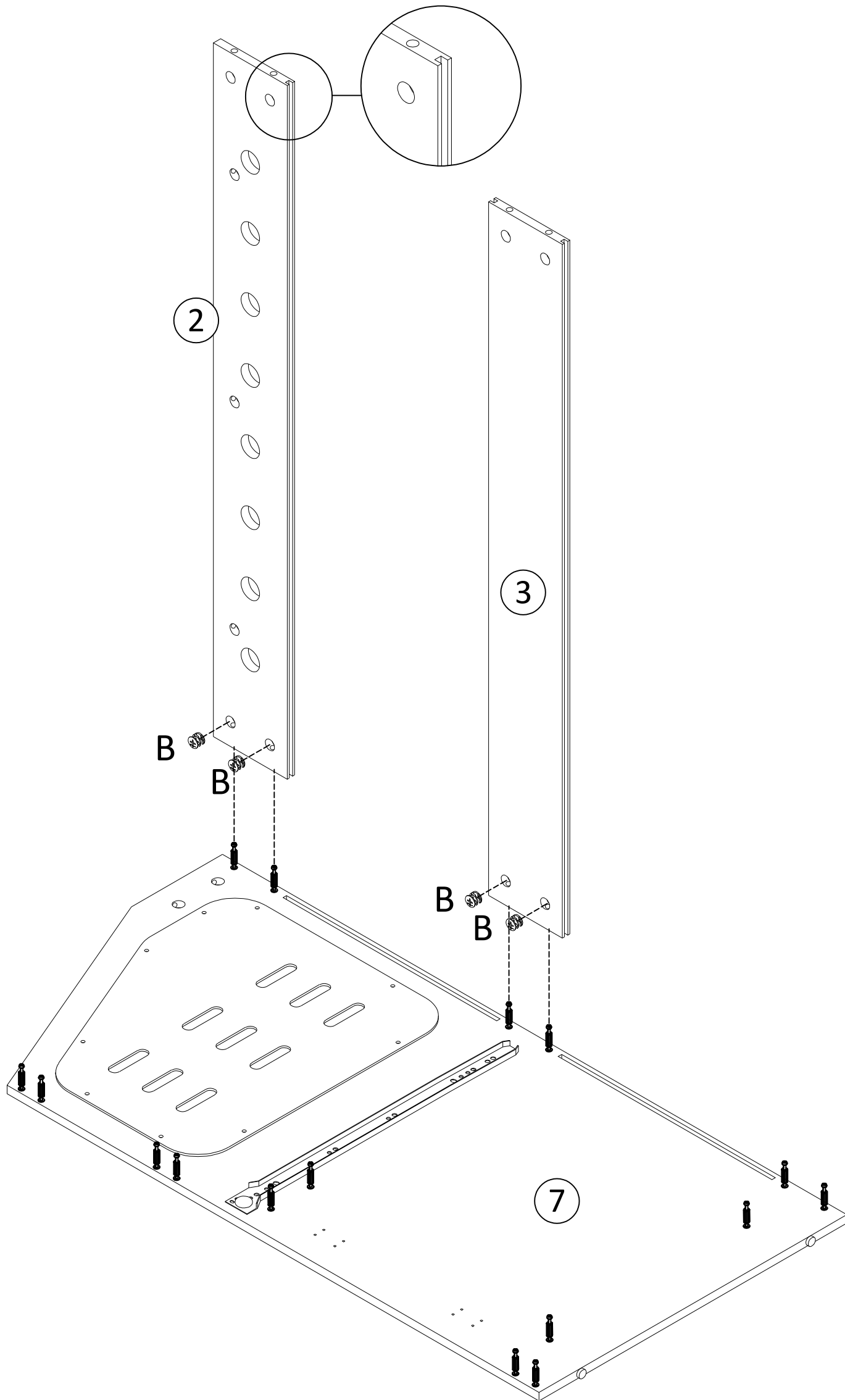

To ensure proper alignment, determine the installation direction of Part 2 and Part 3 by checking its holes.

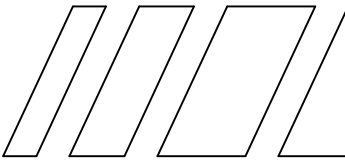

4

C M5x40

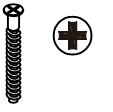

3 PCS

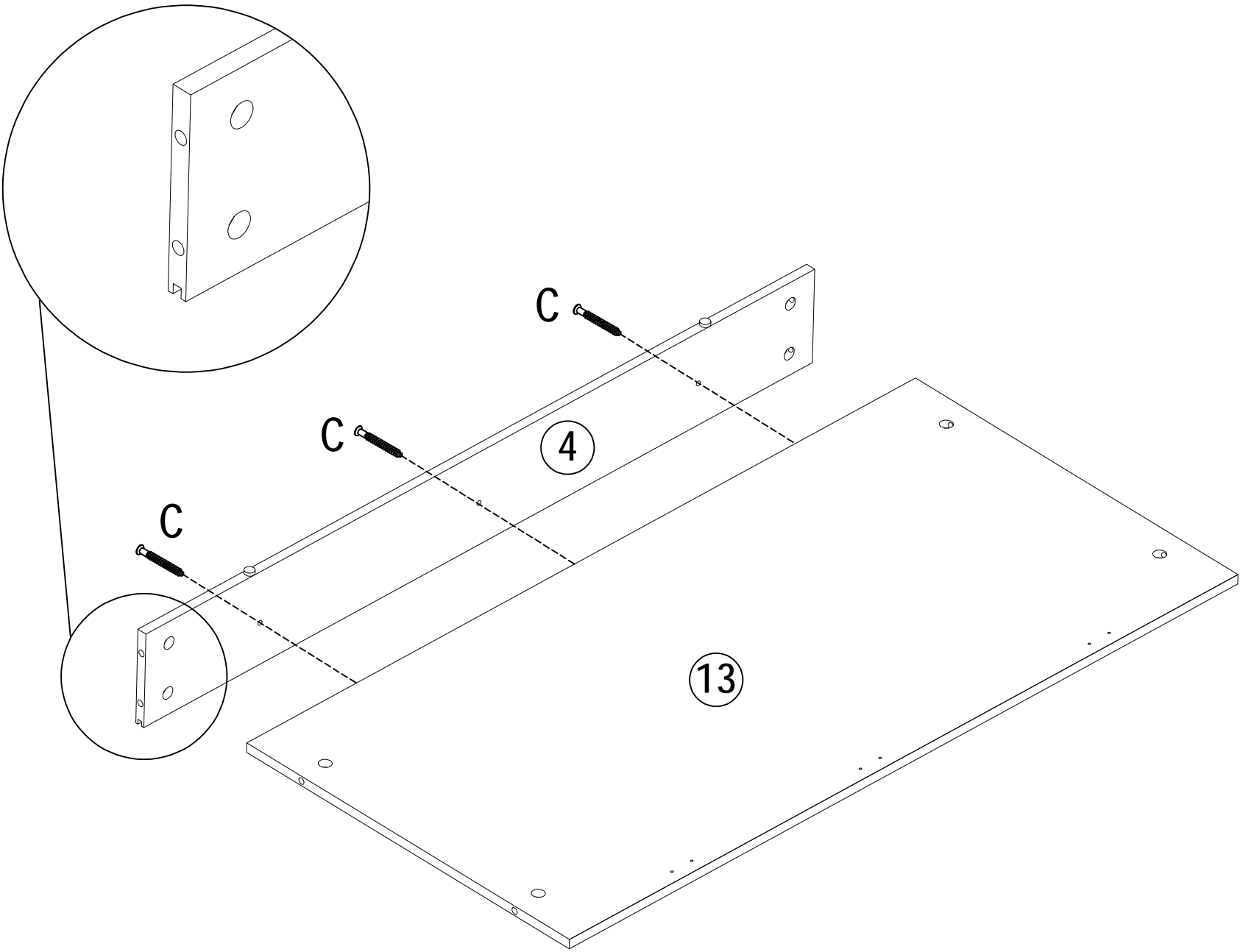

5

B Ø15x10



6 PCS

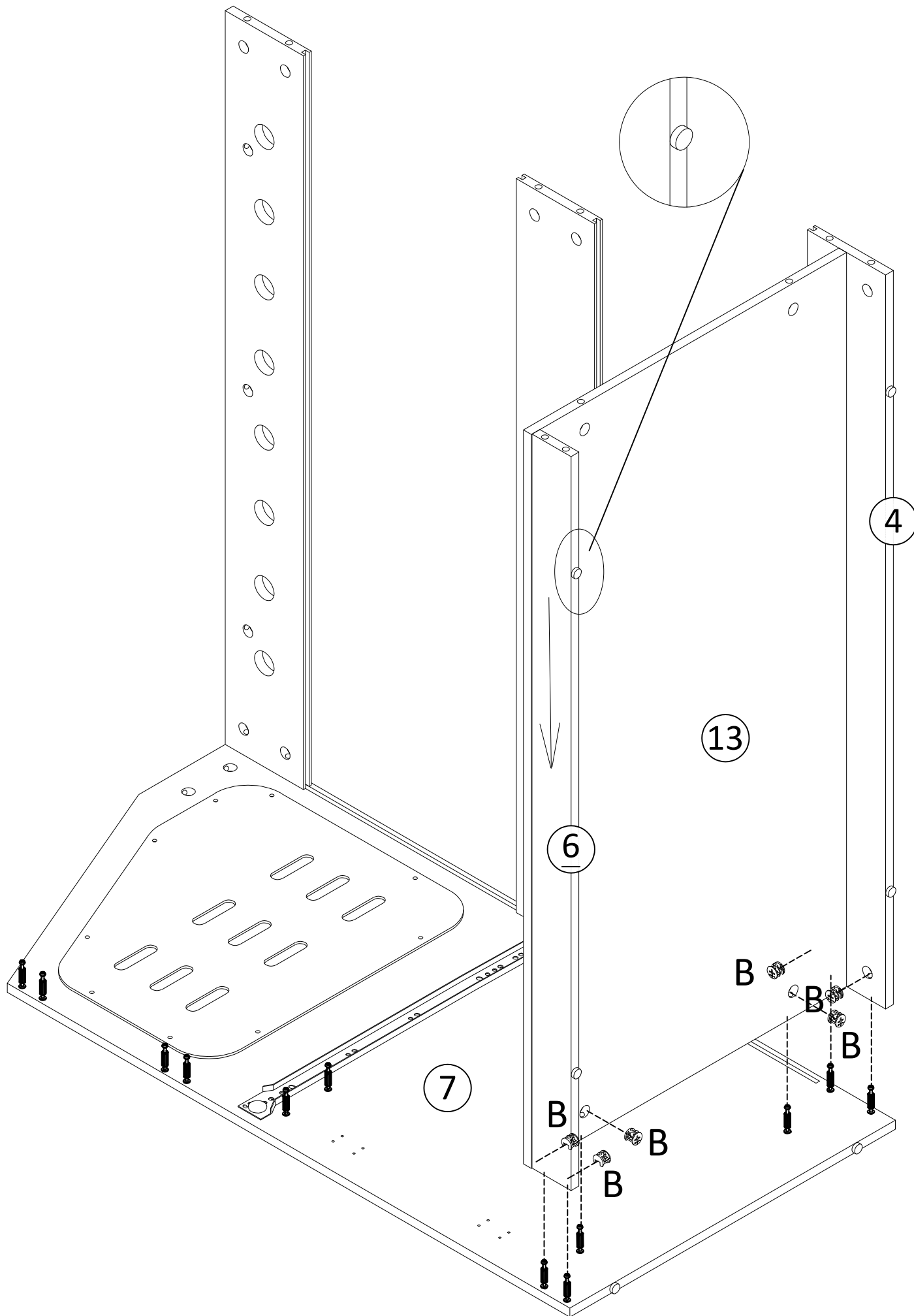

6

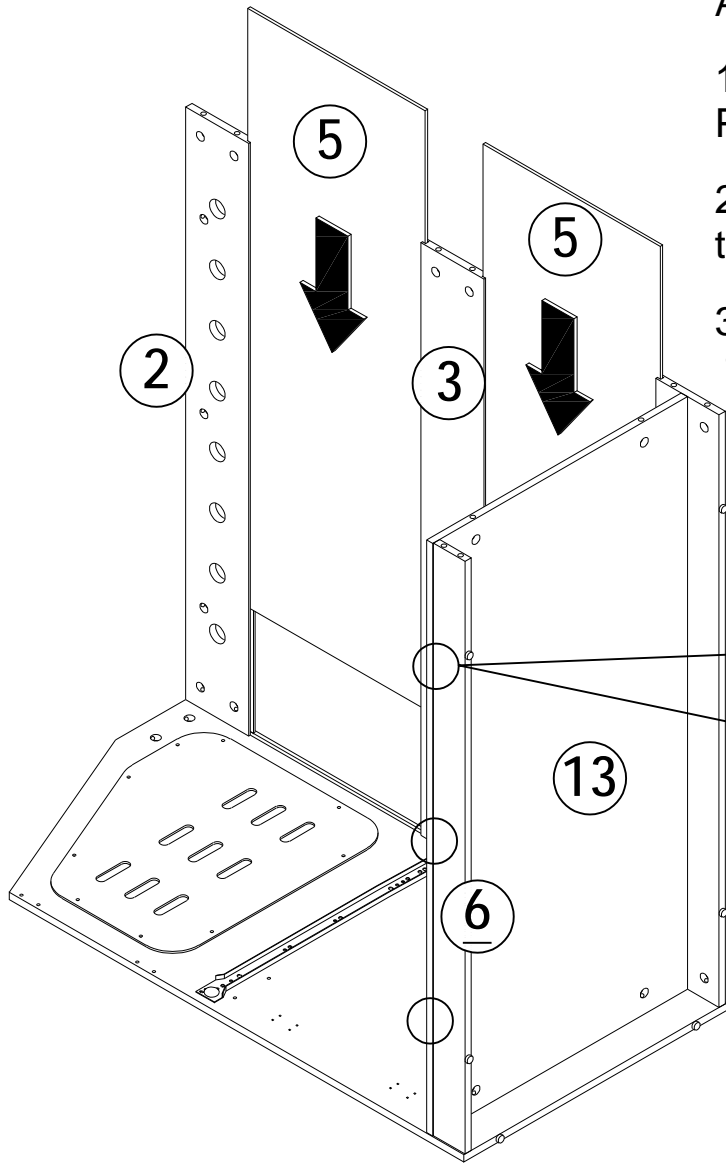

Align and Secure Part L

1. Locate the screw holes on the back of Panel 6 and Panel 13.
2. Carefully lay the product flat (as shown in the illustration).
3. Align Part L with the pre-drilled holes, then tighten the screws to secure it in place.

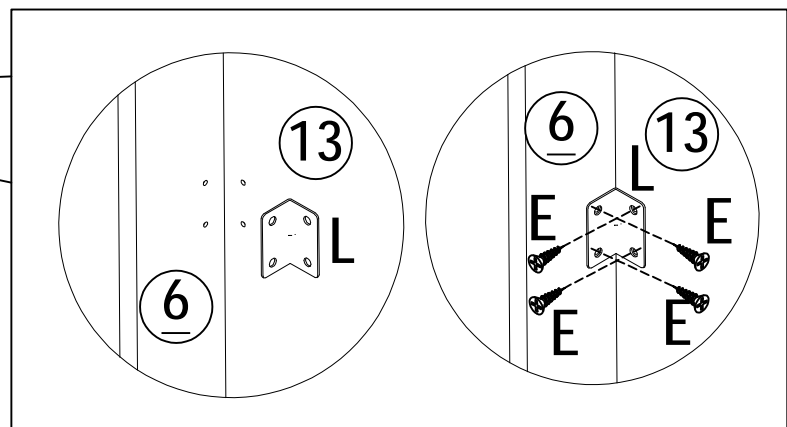

E M3.5x12



12 PCS

L 38x20x25



3 PCS

7

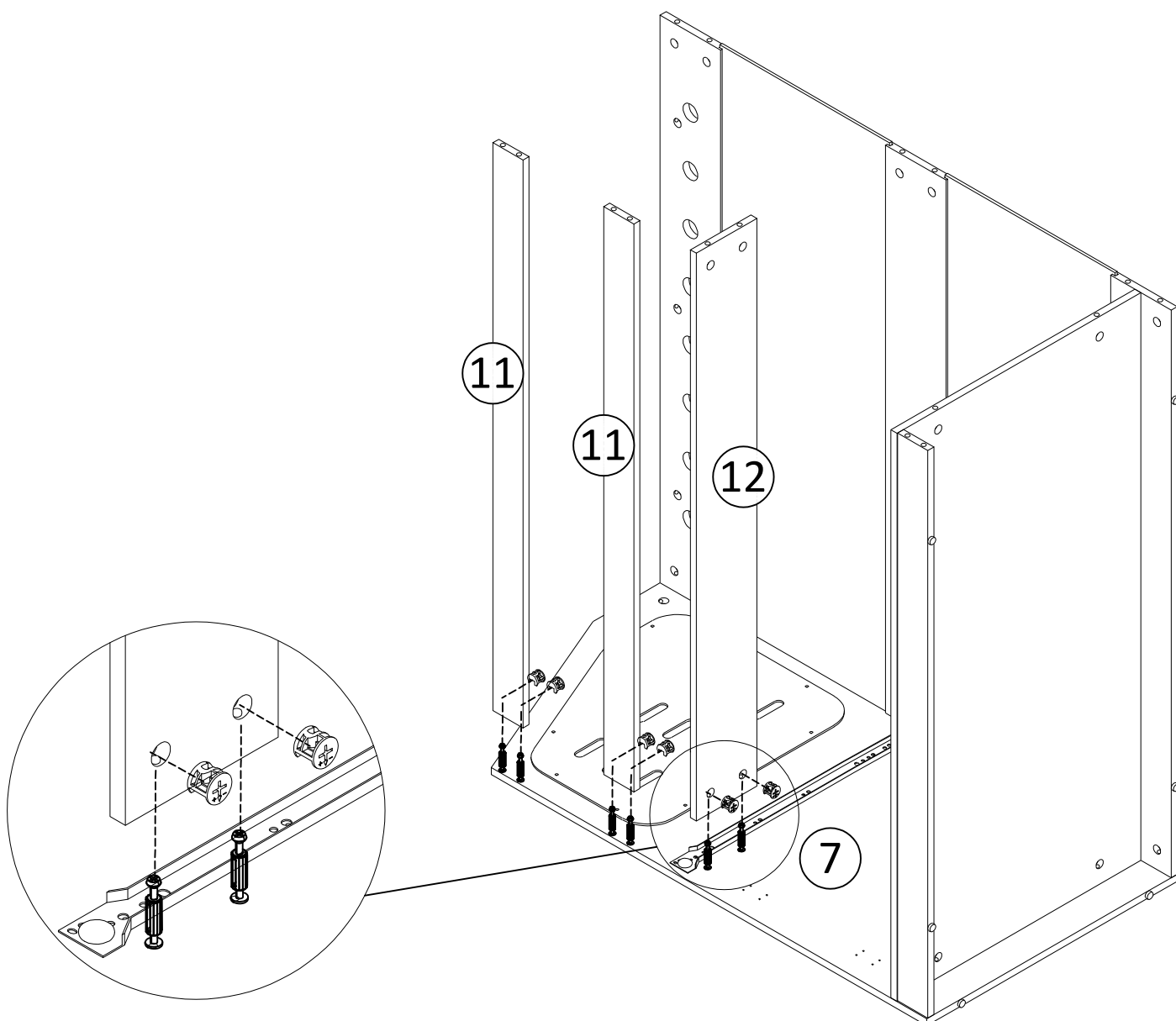

B Ø15x10



6 PCS

8

B Ø15x10



16 PCS

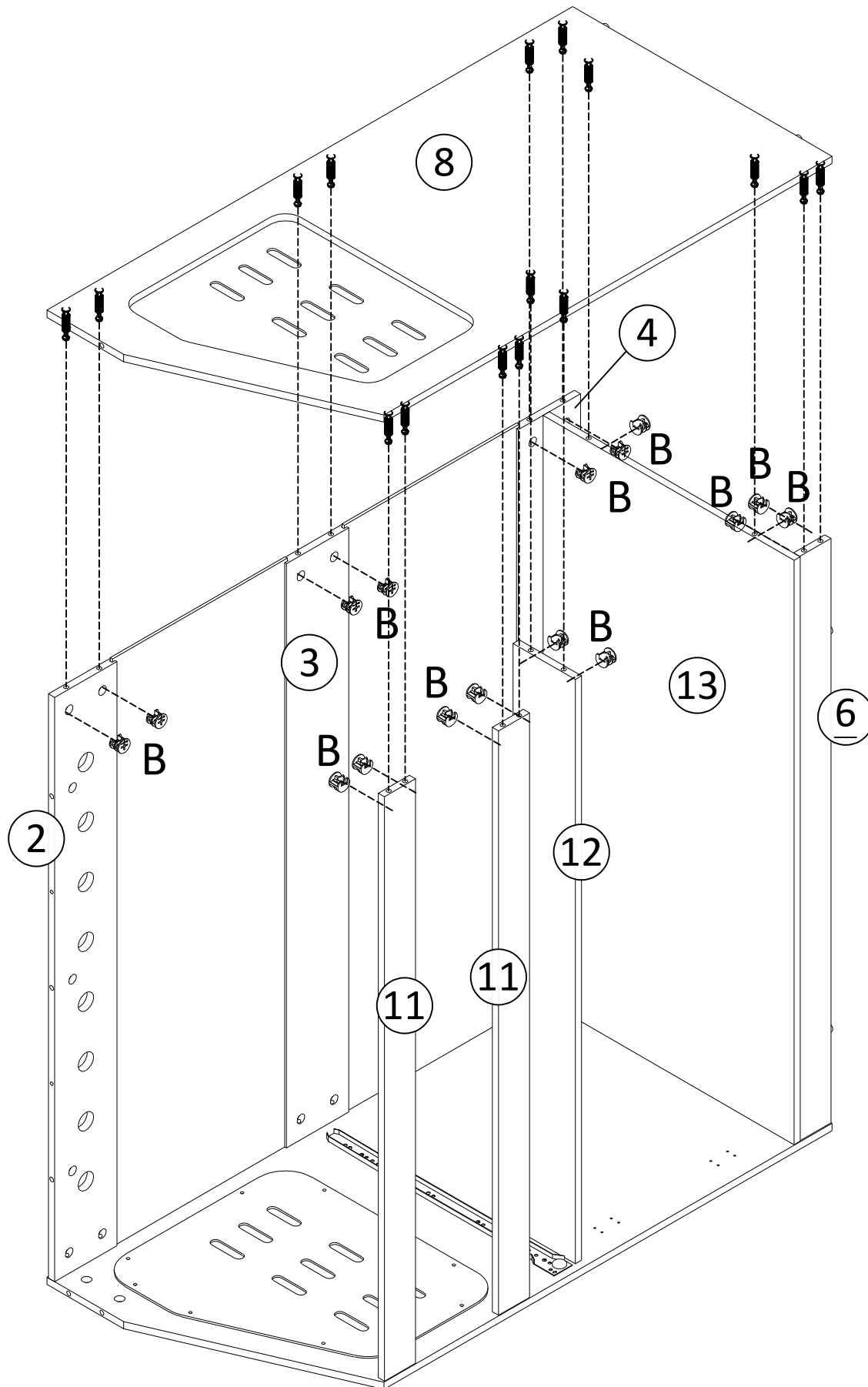

9

First tighten the center screw for positioning,
then install the other screws to prevent misalignment.

E M3.5x12



12 PCS

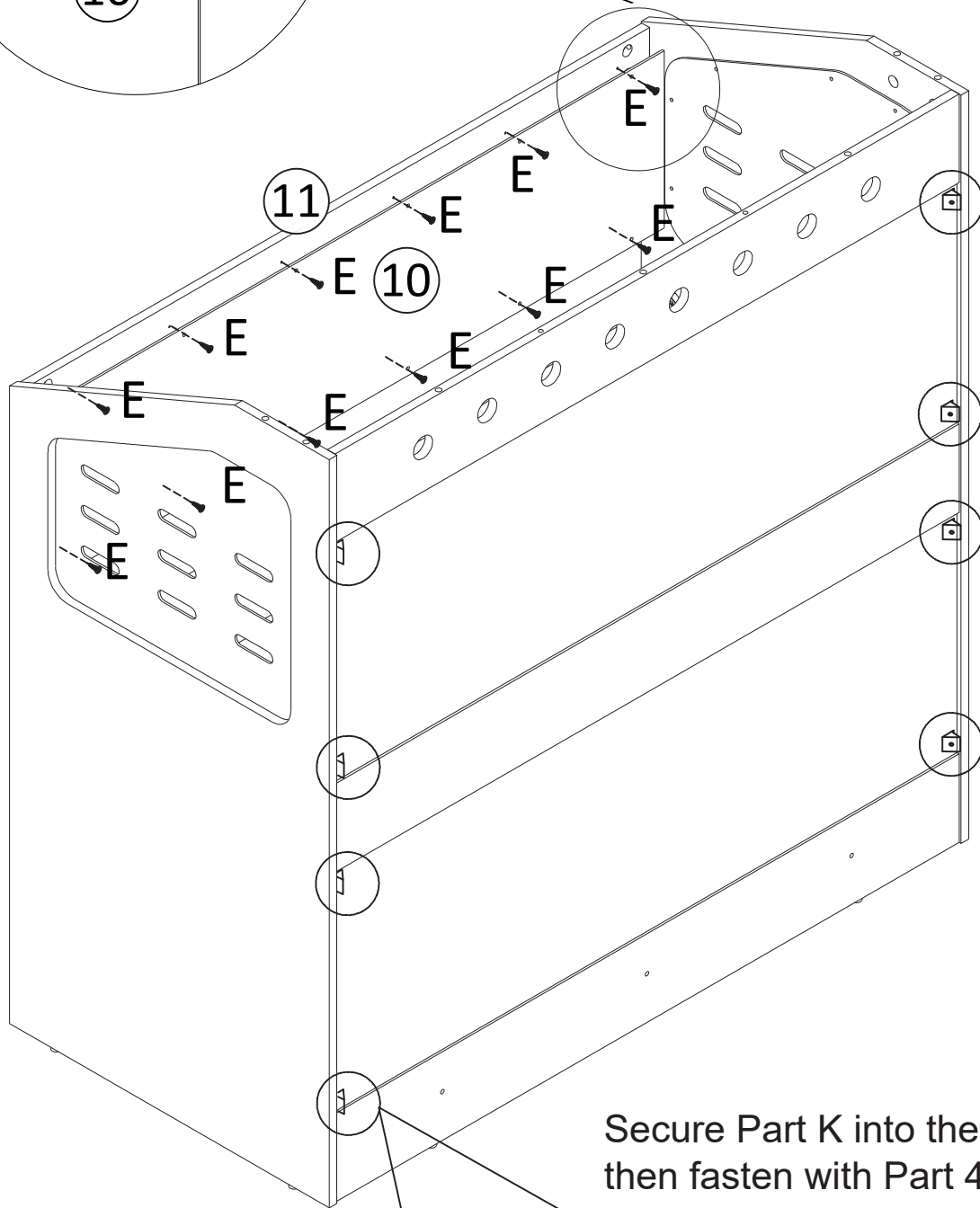
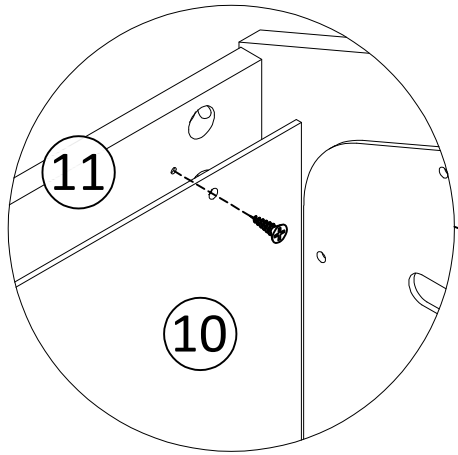

Secure Part K into the panel gap first,
then fasten with Part 4 screws.

K M3.5x14

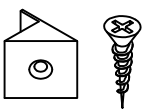

8 SETS

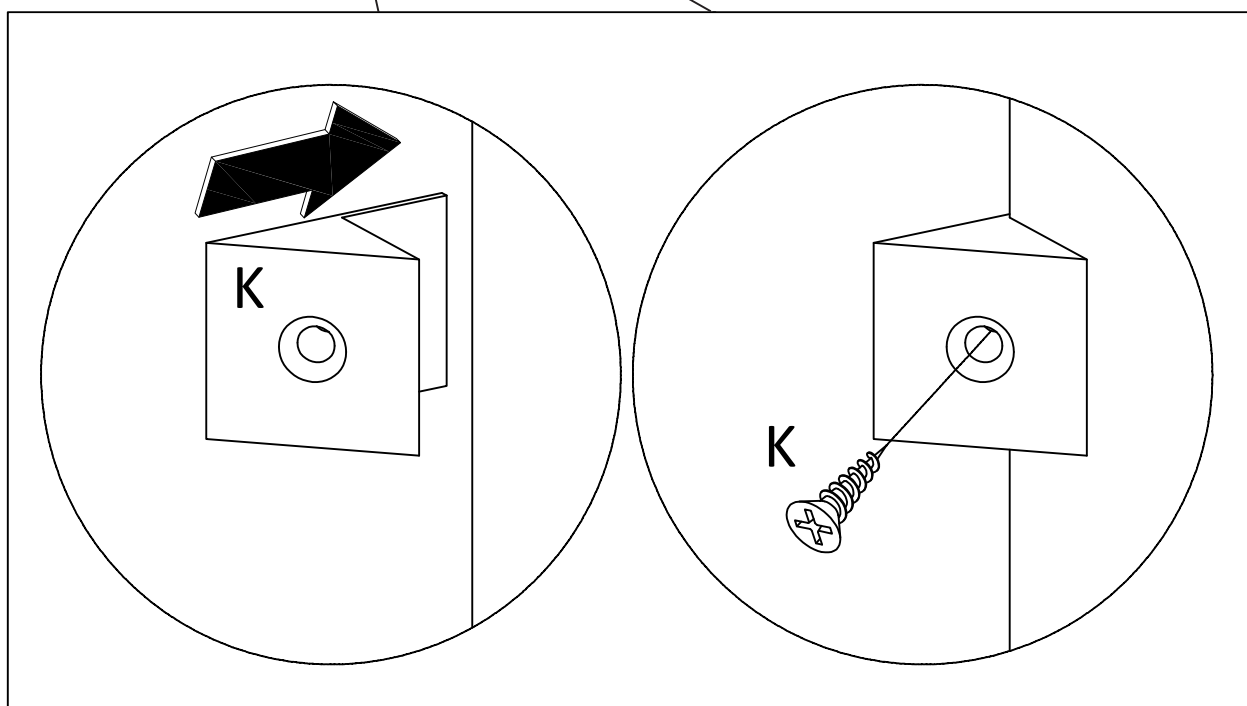

10

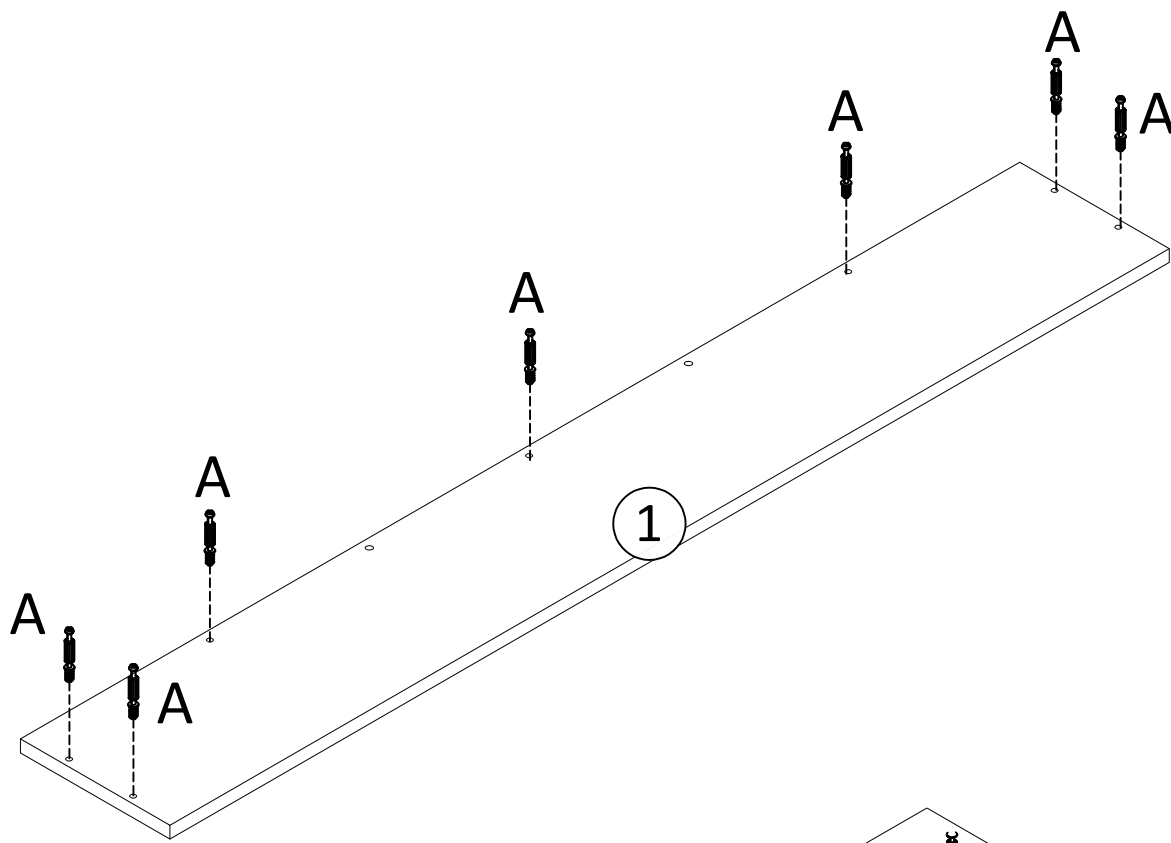

A M5x42



7 PCS

B Ø15x10



7 PCS

D Ø6x40



2 PCS

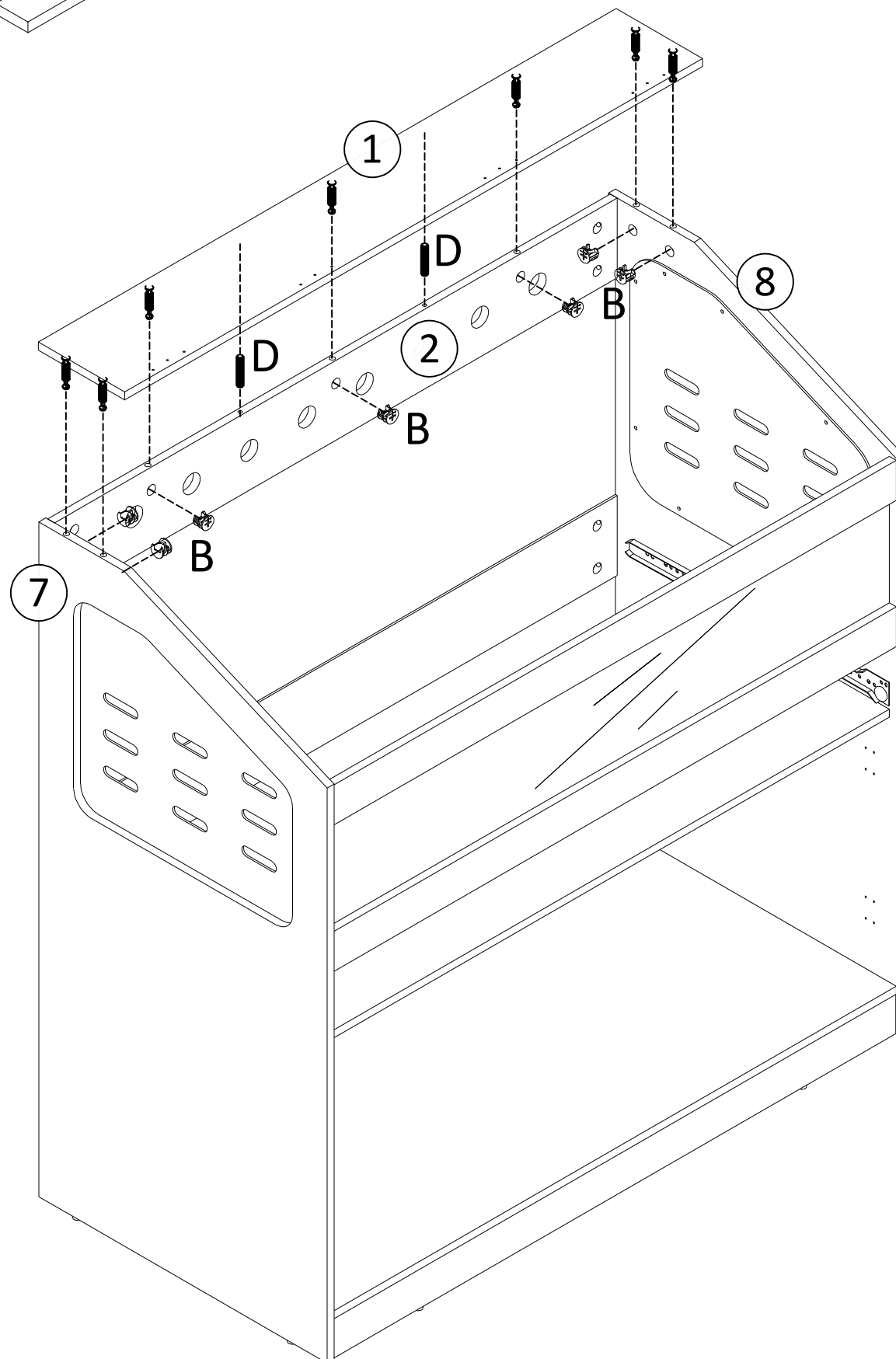

11

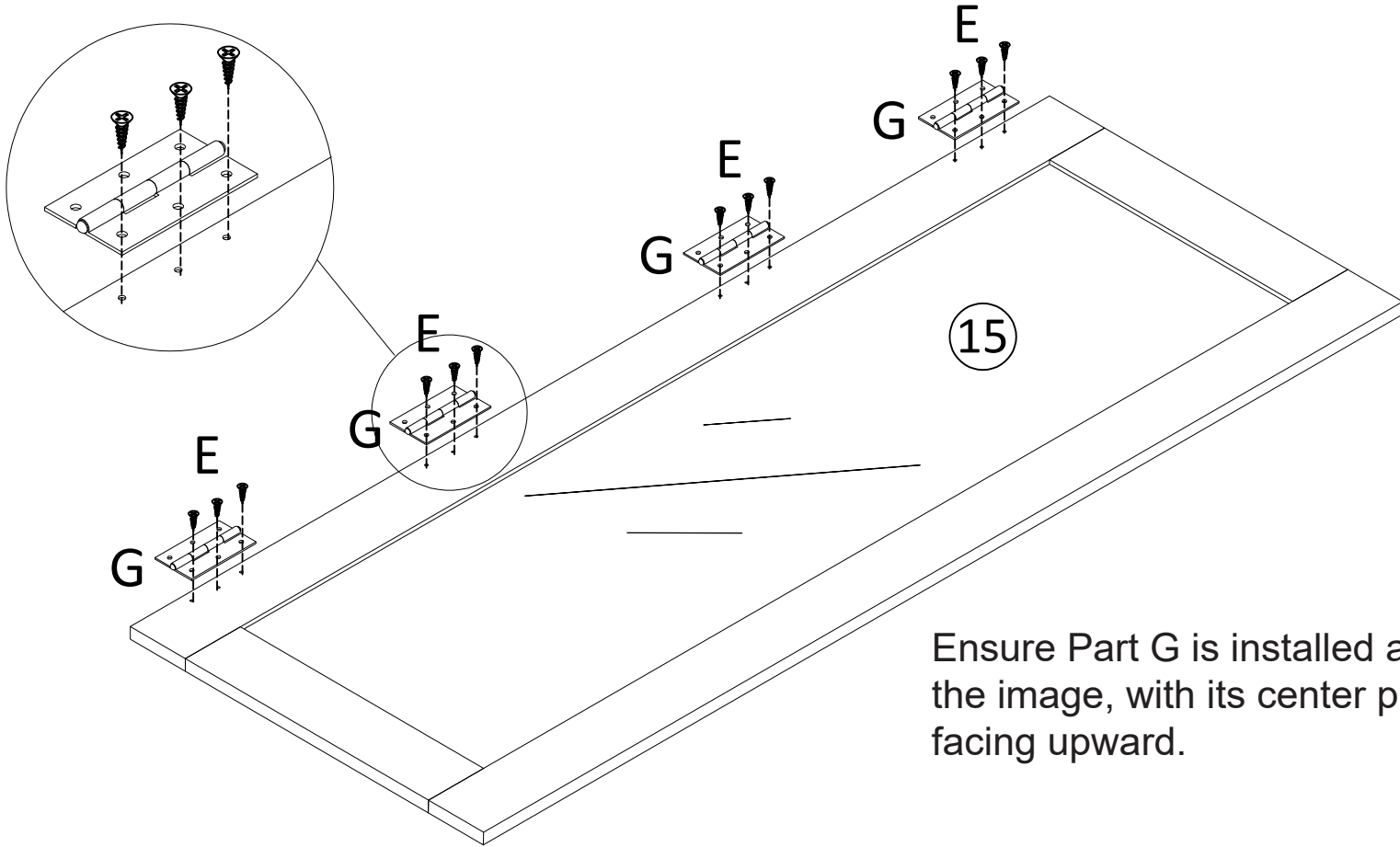

G 70x40

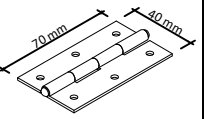

4 PCS

E M3.5x12



24 PCS

Ensure Part G is installed as shown in the image, with its center protrusion facing upward.

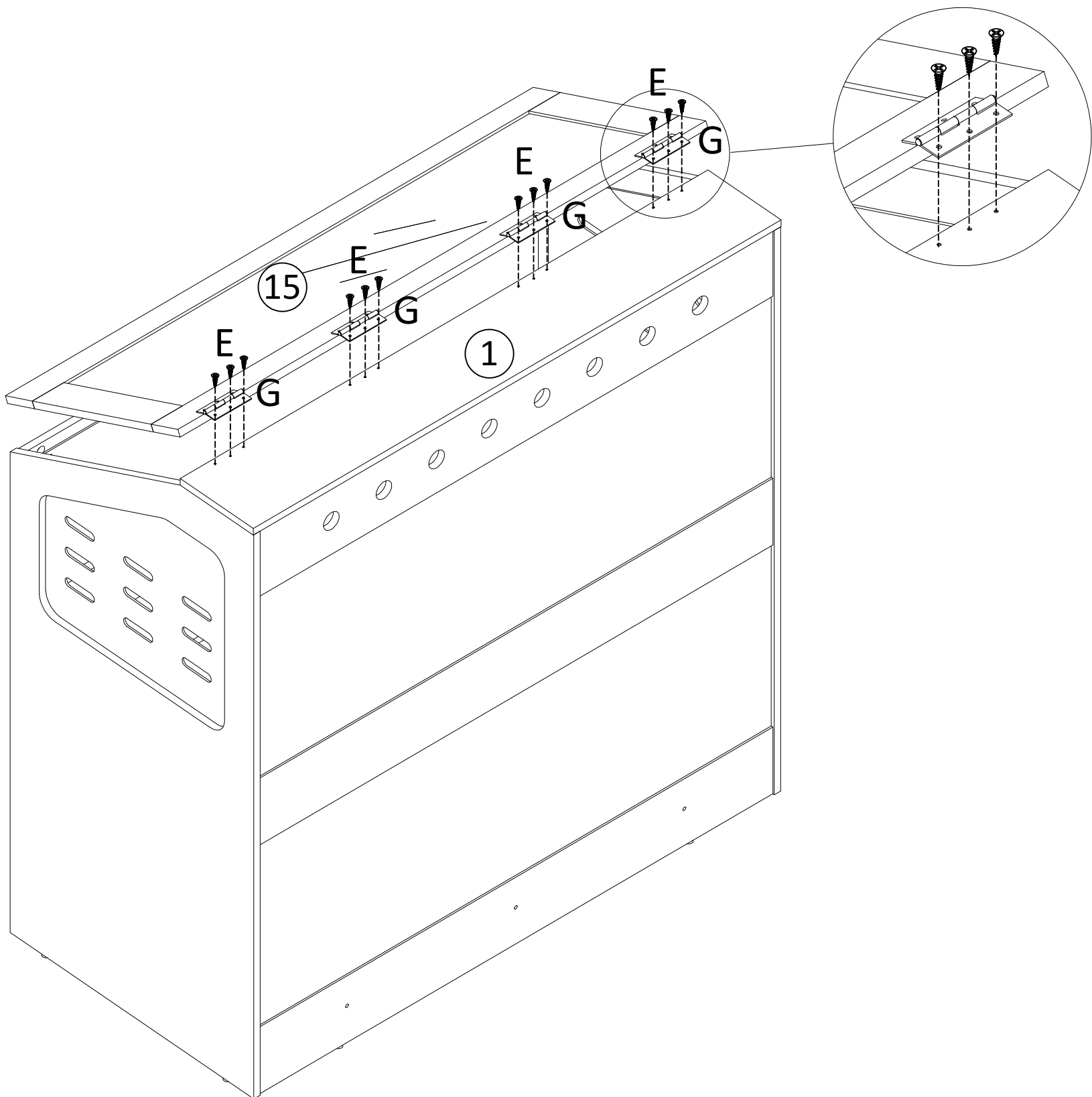

12

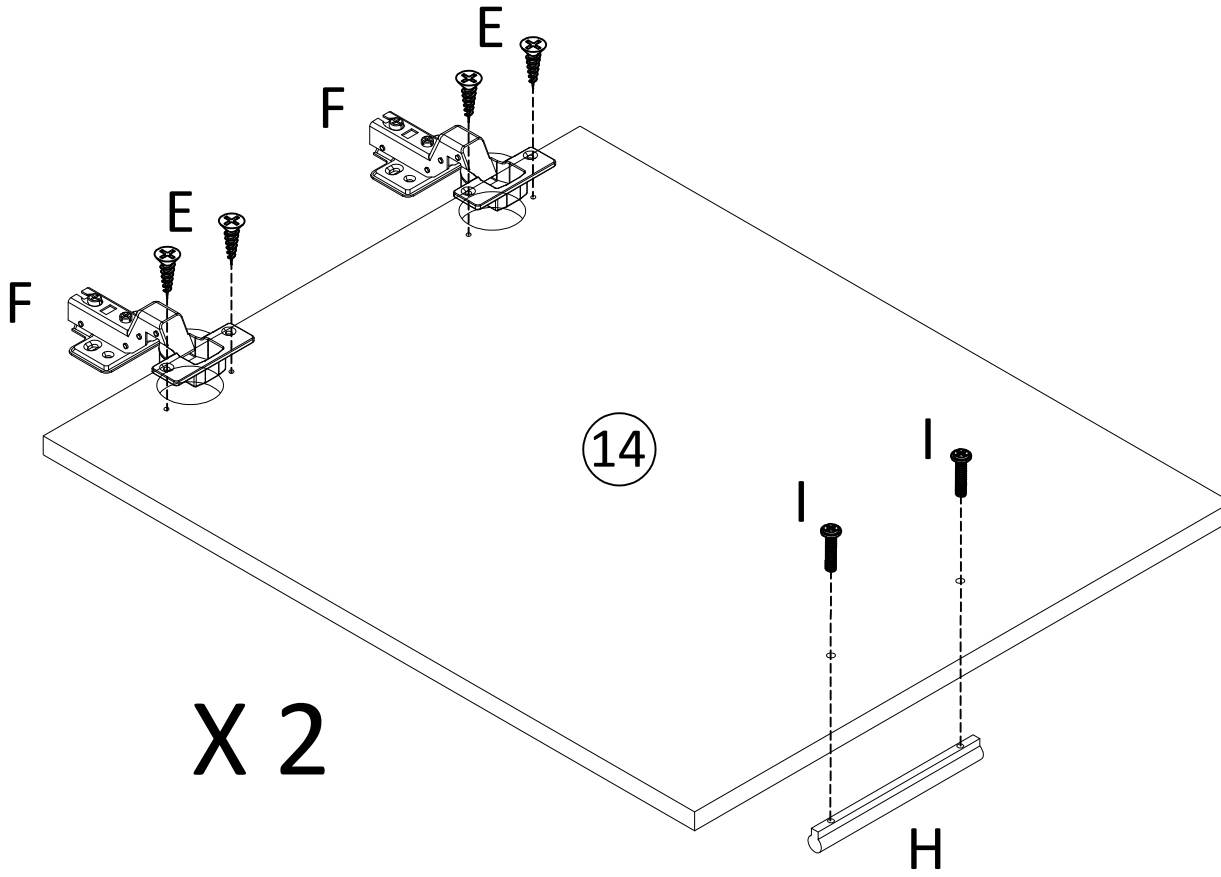

F DW

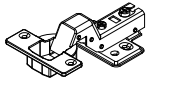

4 PCS

E M3.5x12



24 PCS

H 220-96

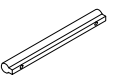

2 PCS

I M4x15



4 PCS

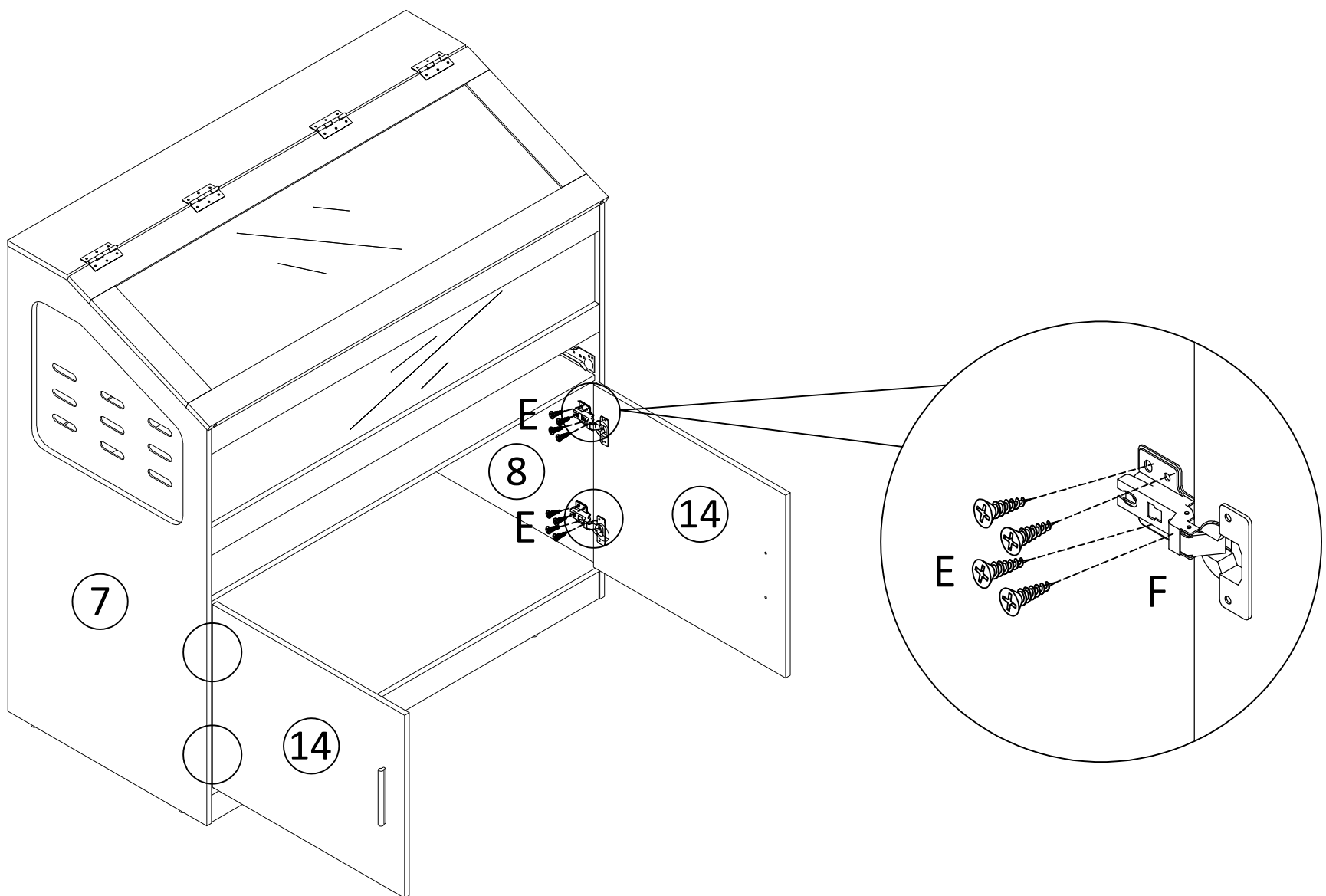

13

C M5x40

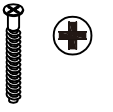

11 PCS

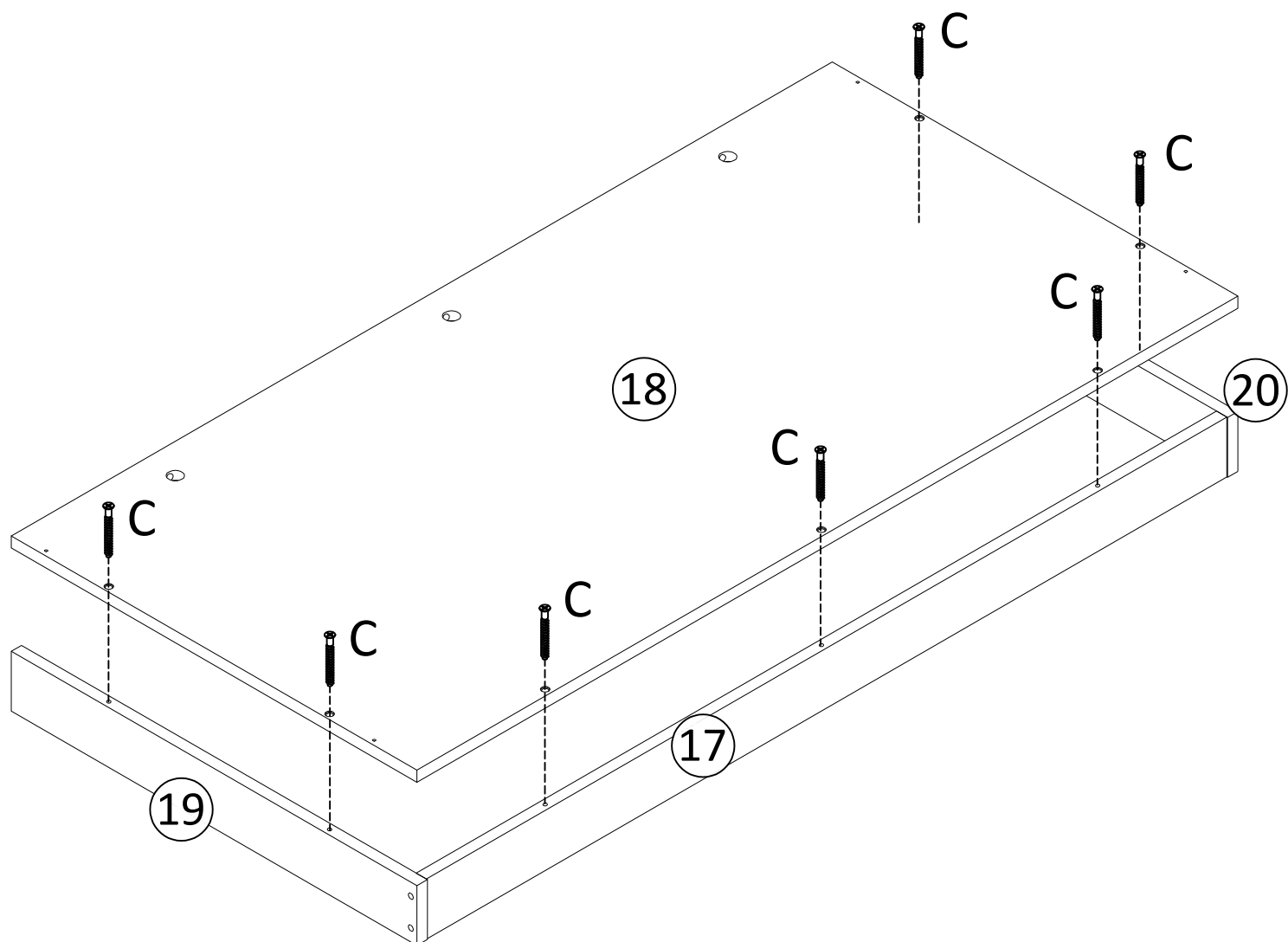
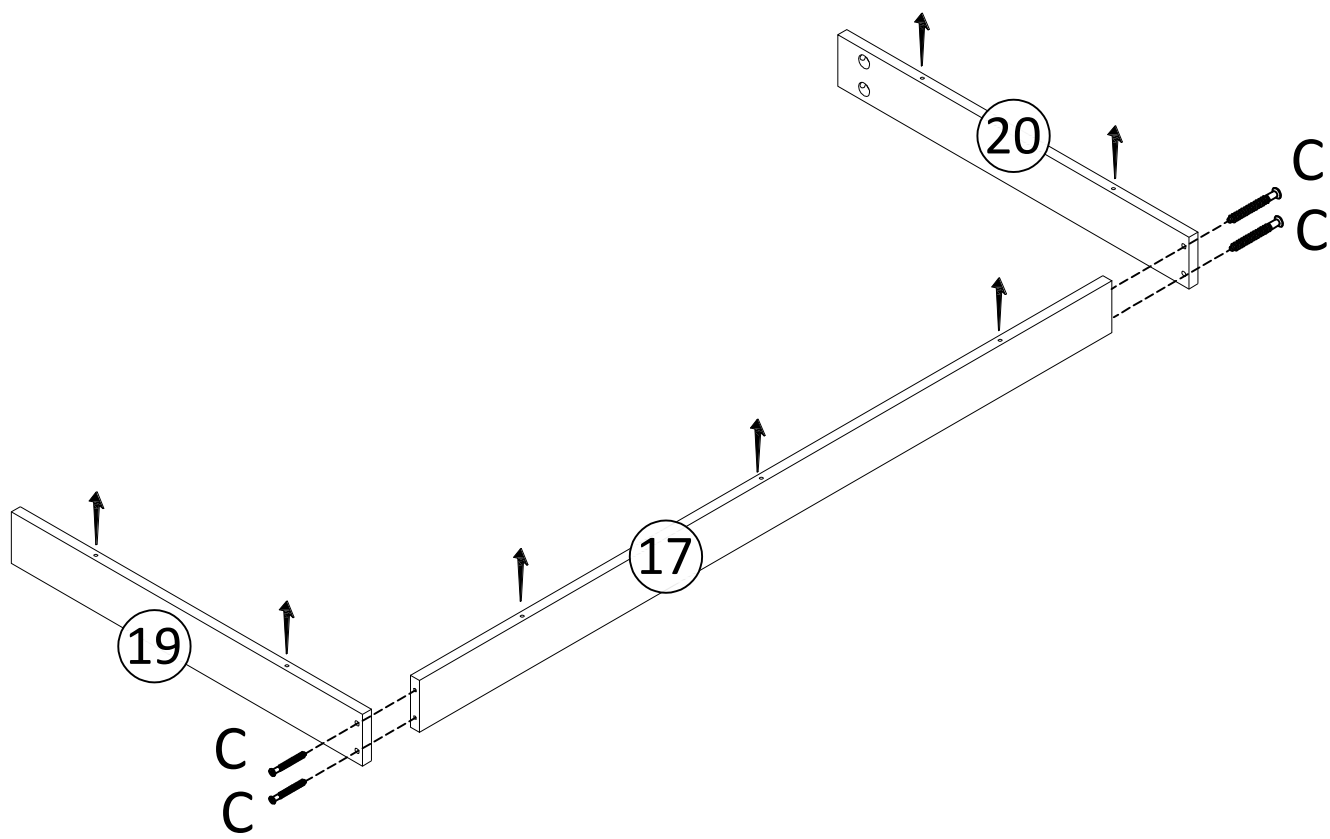

14

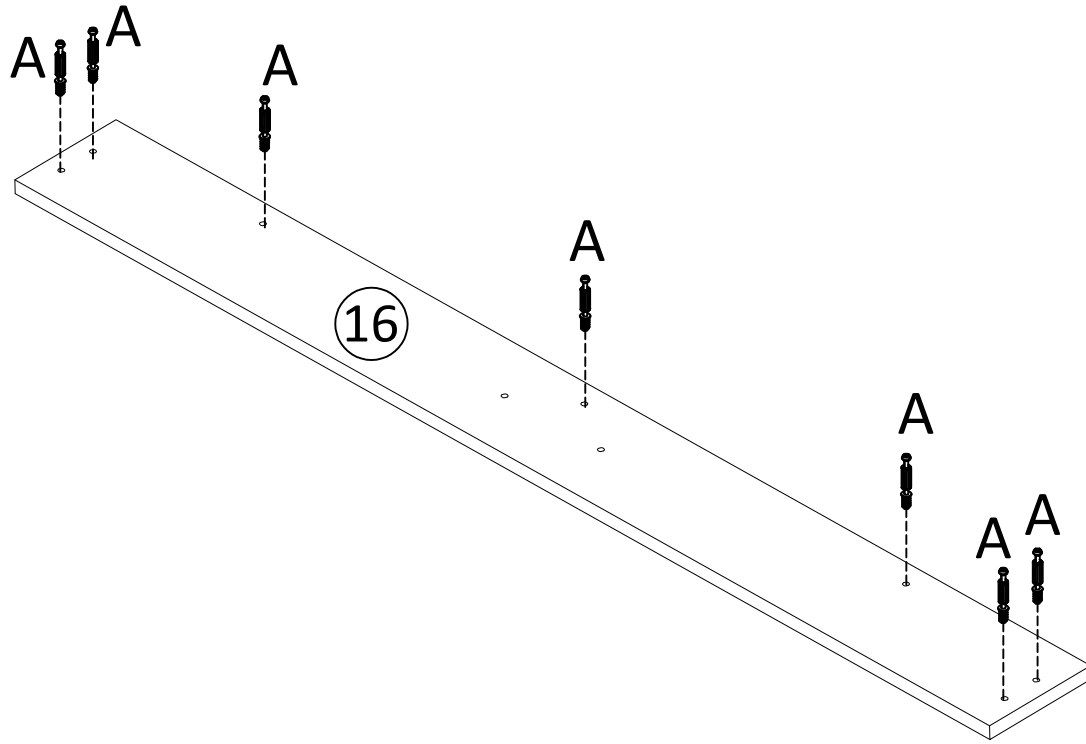

A M5x42



7 PCS

15

B Ø15x10



7 PCS

H 220-96

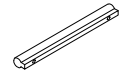

1 PCS

I M4x15



2 PCS

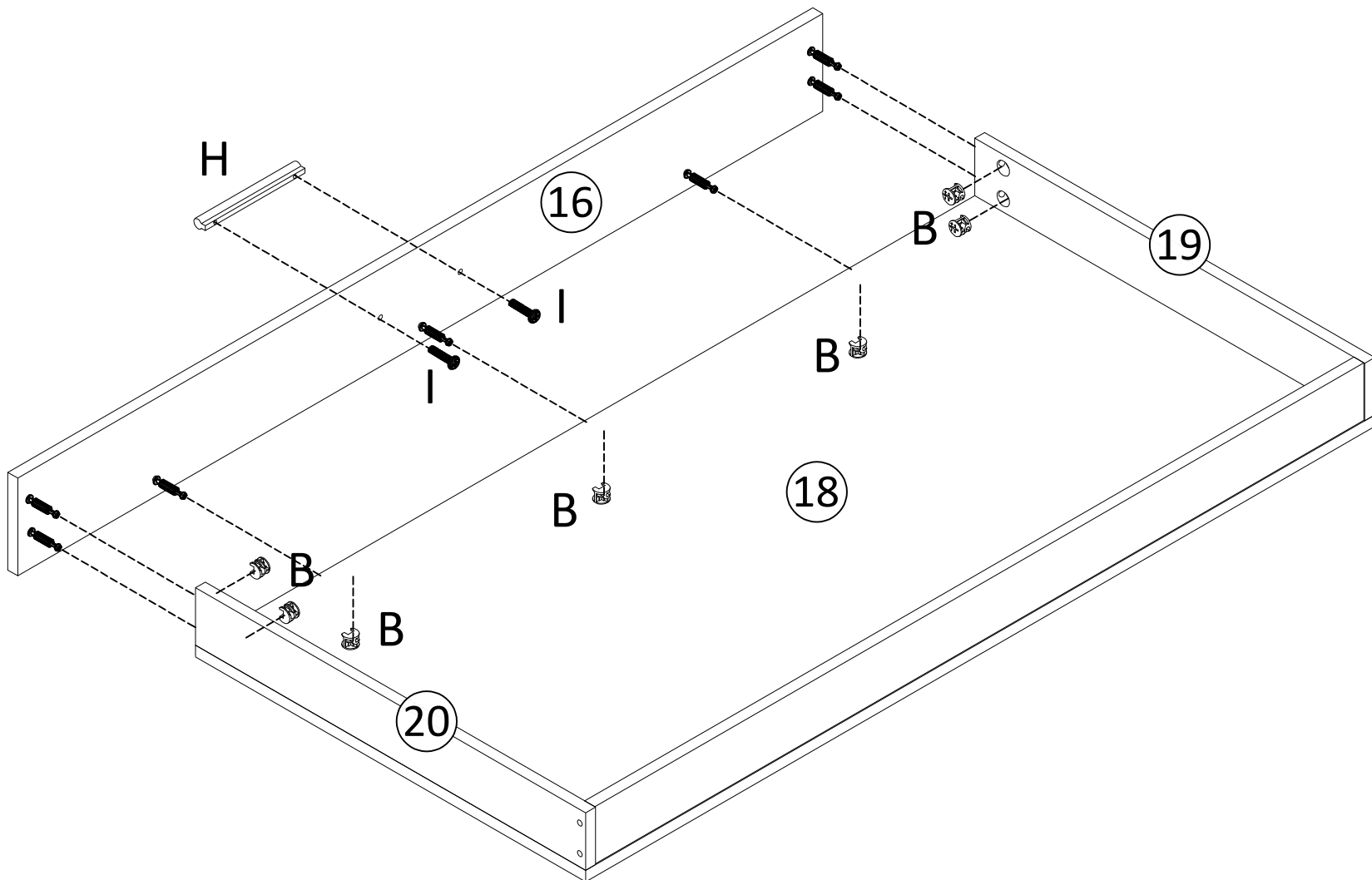

16

When installing Part 21, be sure to follow the installation diagram in the instructions.

E M3.5x12



4 PCS

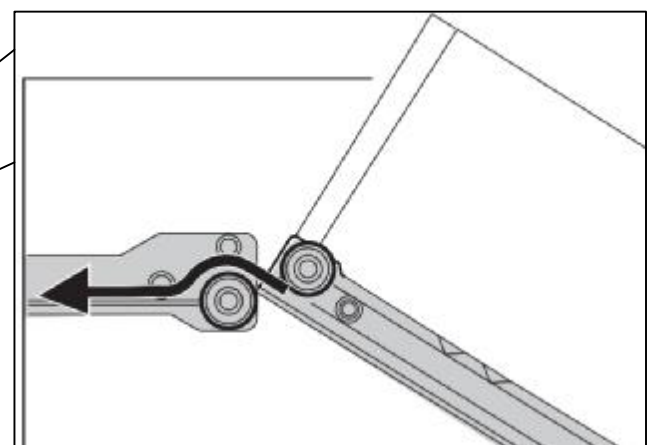
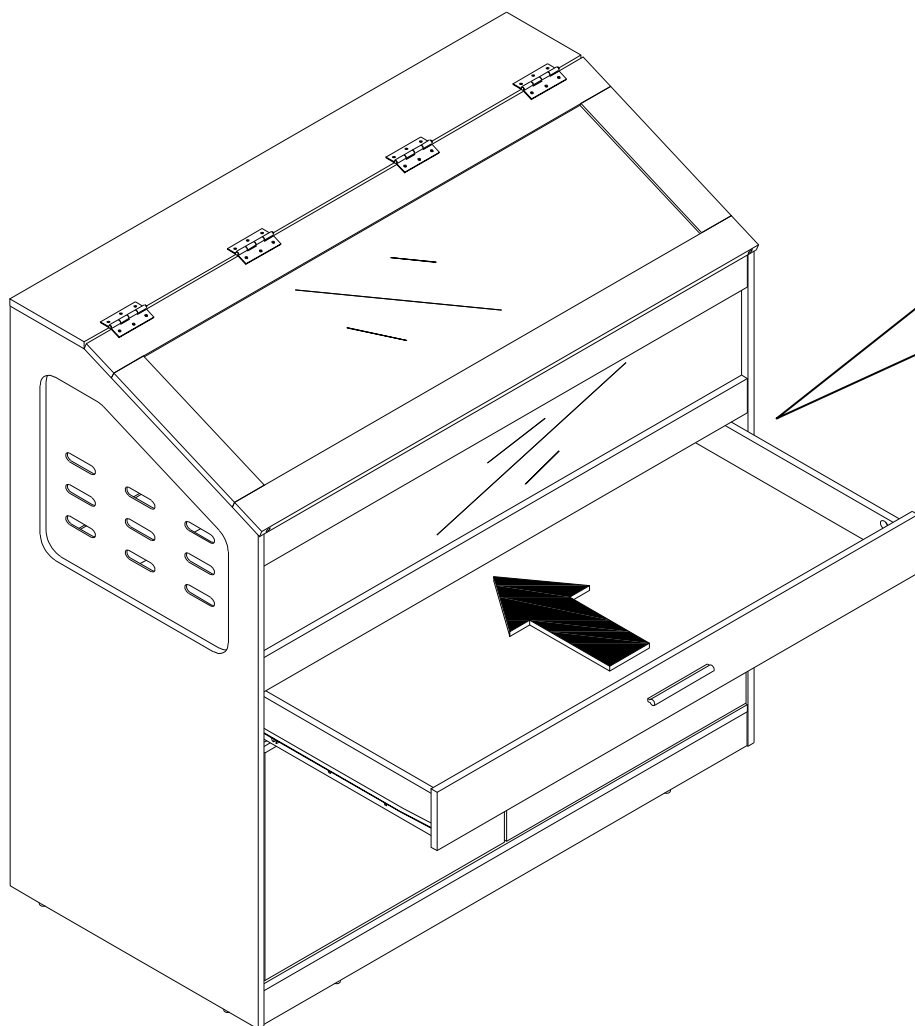
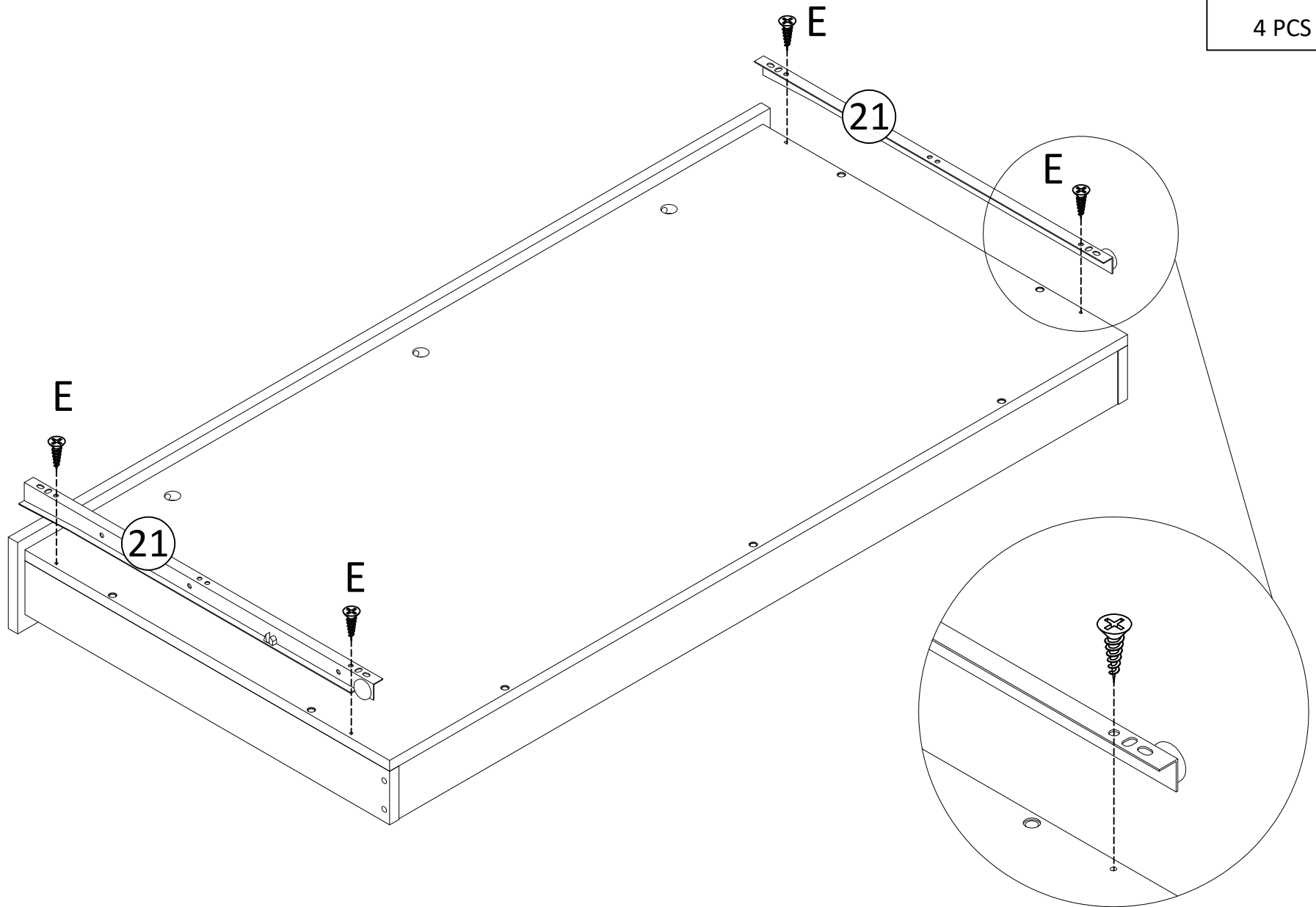

17

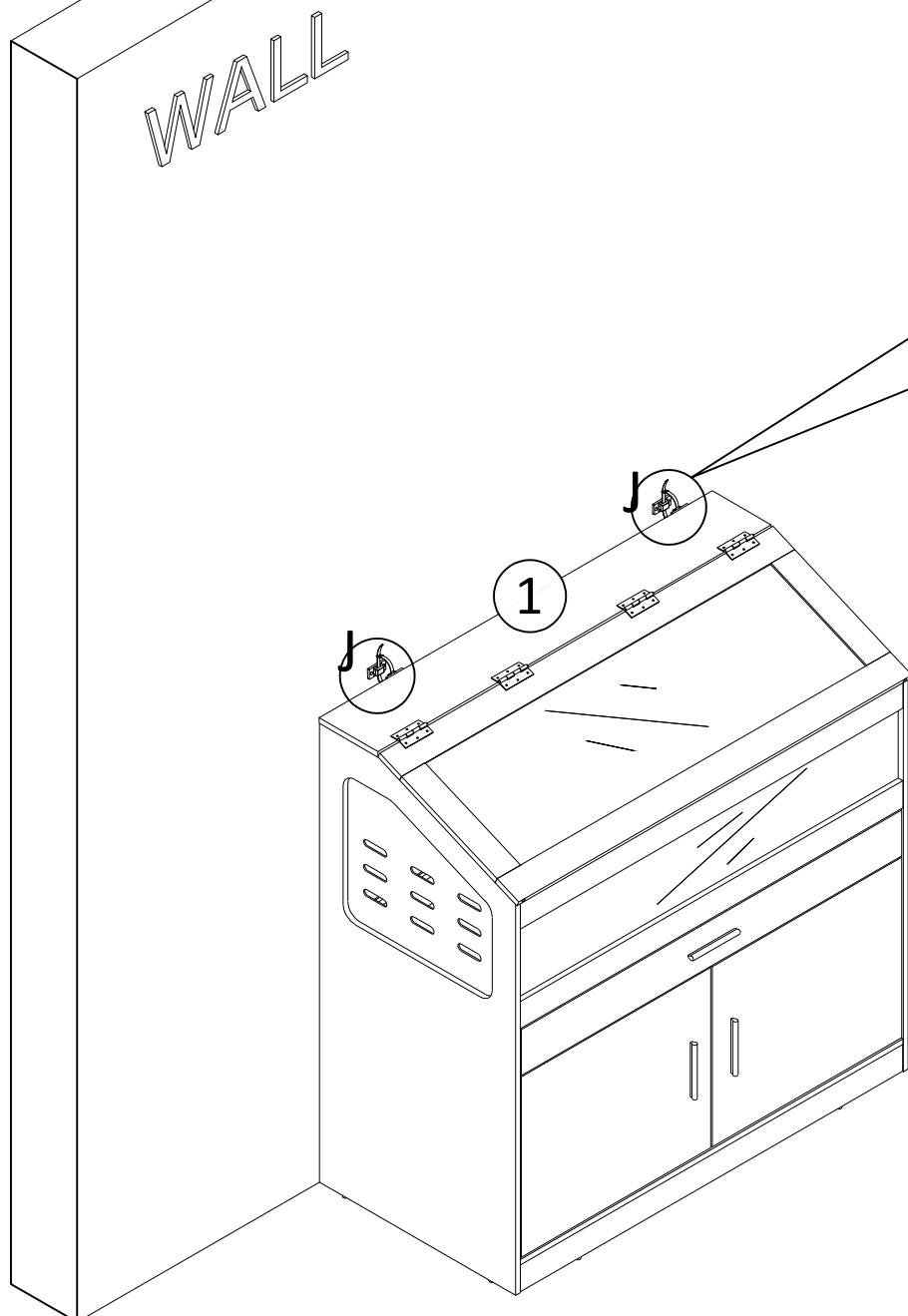

J

2 SET

E M3.5x12

4 PCS

WALL

WALL

WALL

WALL

E

J

WALL

For enhanced stability, install Part J on both the wall and product backplate, then secure with cable ties.
 Note: Always mark drilling positions beforehand.

HELP CENTER

WE STAND BEHIND THE QUALITY OF OUR PRODUCT

1. If you have any other issues with your item(s), please feel free to contact us! We will always do our best to come up with a solution that you will be happy with.
2. Please get in touch with our customer service team before returning the item(s).
3. Please do not throw away the original box(es) if you have not finished assembling and confirmed no quality issues.

RETURN POLICY

Length of return period:

You can return the item(s) within 30 days of purchase.

In the meanwhile, everything you purchased from us comes with a one-year warranty.

Who is responsible for the return shipping fee:

We will cover the return shipping fees if:

1. Your item has a manufacturing defect in materials or workmanship. For example, material cracking or screw hole misalignment. We will send you a prepaid shipping label after you send us photos or videos of the defects.
2. Your item has been damaged in transit. For example, metal part is broken or product is damaged. We will send you a prepaid shipping label after you send us photos of the damage.
3. You receive the wrong box(es) due to a warehouse error, We will send you a prepaid shipping label after you send us photos of the item(s), shipping label(s) and words(SKU) on the outer box(es).

* However, we still hope to work with you for a better solution instead of a return. Please don't hesitate to contact our customer service team.

Customer will cover the return shipping fees if:

1. You don't like the item(s) after receiving the box(es).
2. You no longer need the item(s) but have received the box(es).
3. You buy the item(s) by mistake but have received the box(es).
4. Order/shipment cancellation failed, and you have received the box(es).

Return Request

In order to get a full refund as described in this return policy, all items must be:

1. In a brand new/unused condition. Please provide photos before and after packaging.
2. All accessories and parts must be firmly packed in all original packaging before returning. If your return does not meet these requirements, you may not receive a full refund.

When can I receive a refund?

After you return it using the prepaid shipping label we provided and inform us, the refund will be issued once the package(s) have been returned to our warehouse.

What if the product is damaged/defective outside of the valid return period?

We want you to be a happy customer. Please reach out to us via email or text, and we will work on a solution to ensure your satisfaction.