

Two Bike Wall Mount Rack w/shelf

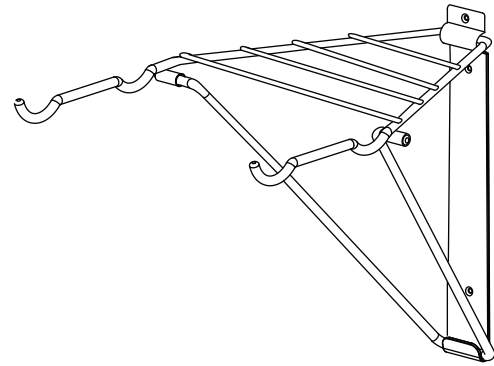

Assembly instructions

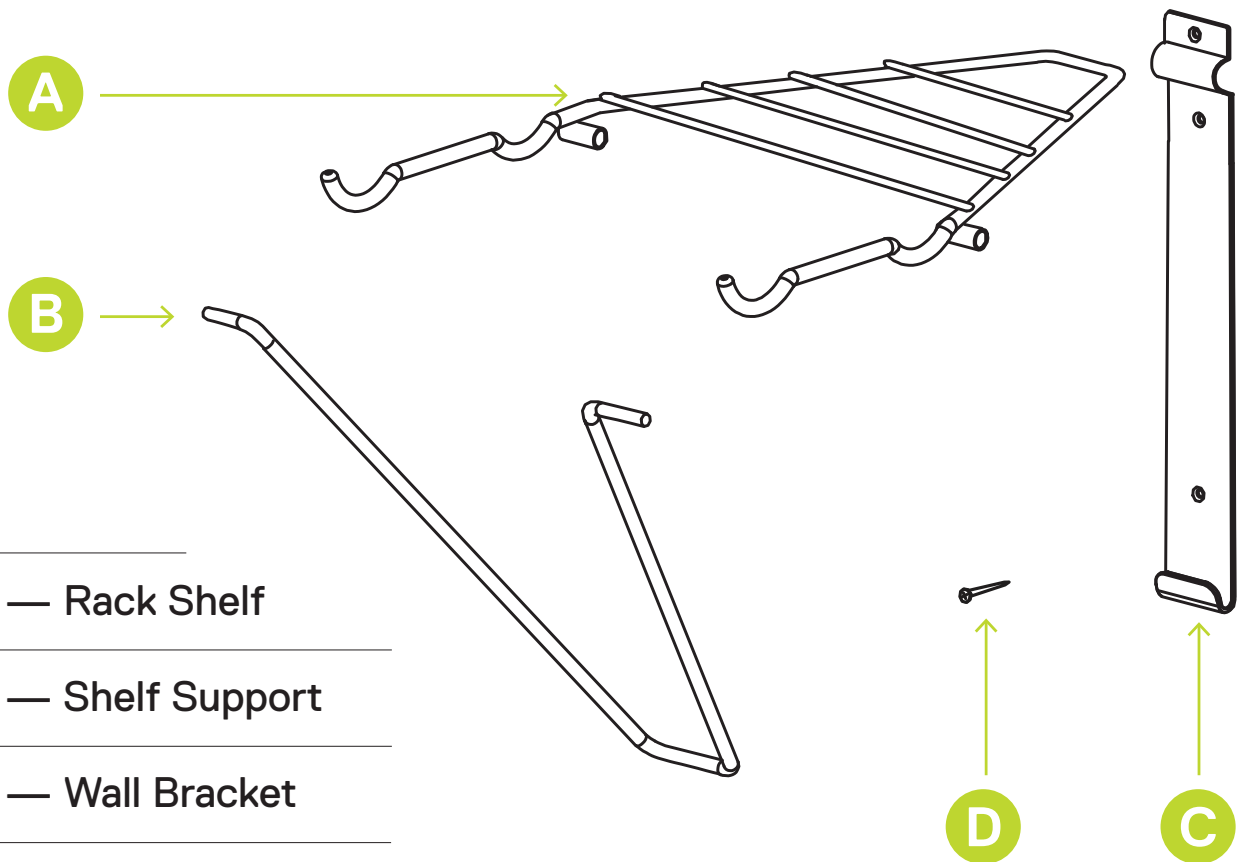

Parts

- A** x1 — Rack Shelf
- B** x1 — Shelf Support
- C** x1 — Wall Bracket
- D** x3 — Screws

Tool(s) Required

Phillips Head
Screwdriver

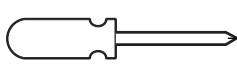

Drill

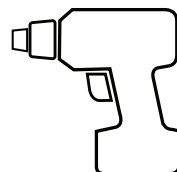

WARNING

NEVER EXCEED MAXIMUM TOTAL WEIGHT LIMIT OF 65 LBS (30 Kgs)
INCORRECT WALL MOUNTING COULD RESULT IN ITEMS FALLING AND INJURY TO PERSONS.

IMPROPER INSTALLATION OR USE CAN RESULT IN PERSONAL INJURY AND/OR DAMAGE TO
PROPERTY

1 Locate stud beneath wallboard.
Position wall bracket at desired height.

Before mounting wall bracket position rack shelf behind upper part of bracket. (Figure 1)
Make sure the rack shelf is level when mounting. Once in correct position screw into place. (screws should be in the center of Wall Stud)



IMPORTANT SAFETY NOTE

Beware of drilling into electrical wire or pipes within wall!

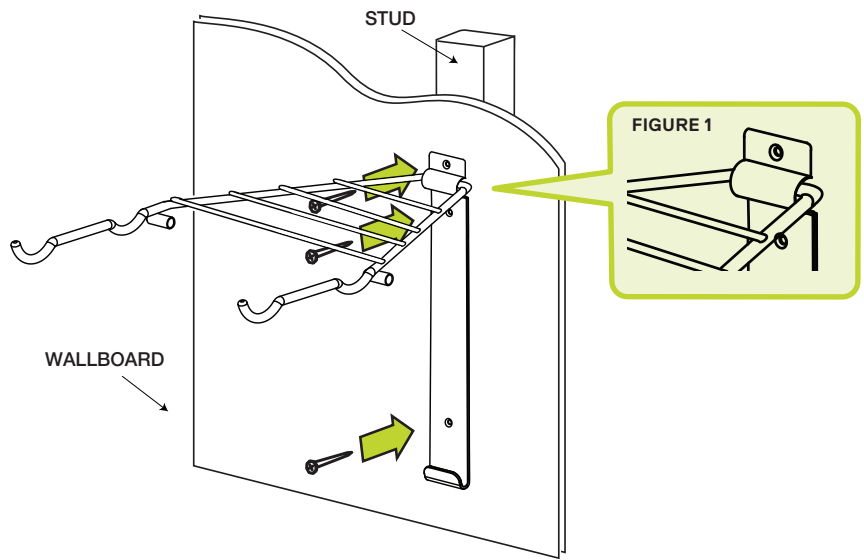

2 Compress shelf support slightly and release into holes on shelf. (Figure 2)

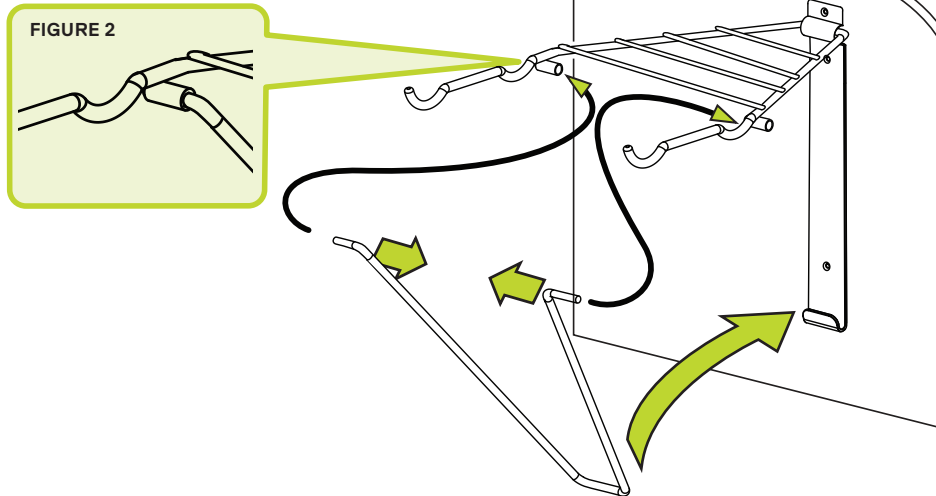

3 Make sure that shelf support is securely placed in bottom of wall bracket. (Figure 3)

