

ASSEMBLY INSTRUCTIONS

SIDE CHAIRS (SET OF 2 CHAIRS)







Please read instructions carefully

Remove all wrapping materials, staples and packing straps from the carton. Refer to Parts List and Hardware List and ensure they are complete before you start assembling. Place all wooden parts on a clean, flat and soft surface (e.g carpet or rug) to prevent parts from being scratched.

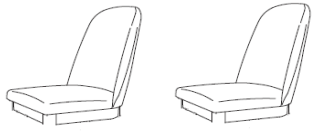
CAUTIONS: 1) DO NOT FULLY TIGHTEN BOLTS AND NUTS UNTIL ALL PARTS HAVE BEEN ASSEMBLED.

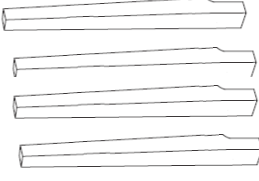
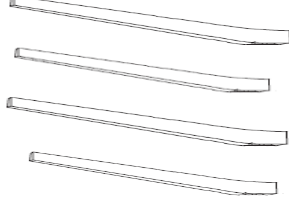
2) DO NOT OVER-TIGHTEN BOLTS AND NUTS .

3) KEEP ALL HARDWARE PARTS OUT OF REACH OF CHILDREN.

Carton	Part	Designation	Part List	QTY	HARDWARE	Hardware List
1	P1	CHAIR SEAT FRAME		P1 x 2pc	H1	 H1 x 16pc
	P2	FRONT LEGS		P2 x 4pc		M6x60mm JCBC SCREW
	P3	BACK LEGS		P3 x 4pc	H2	 H2 x 16pc
					H3	 H3 x 16pc Flat Washer
					H4	 H4 x 1pc Allen Key

COMPLETE ASSEMBLY

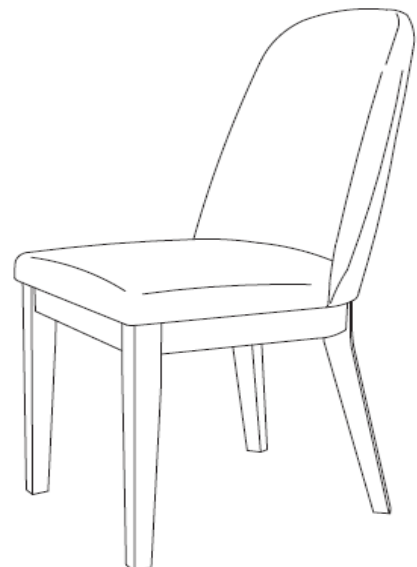
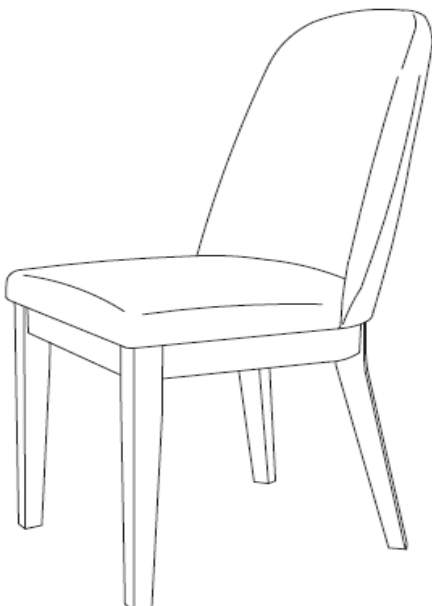



ASSEMBLY INSTRUCTIONS

SIDE CHAIRS (SET OF 2 CHAIRS)

STEP 1

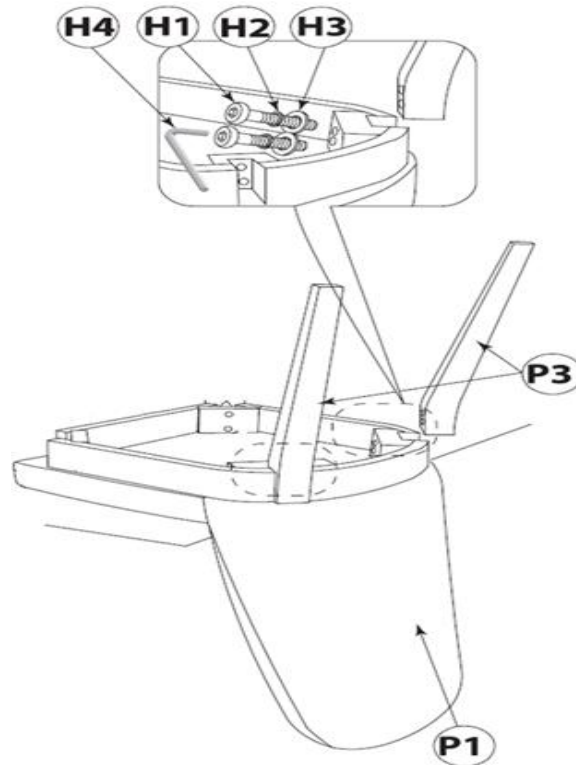

Take two back legs (P3) and connect it to the chair seat frame with corresponding hardware

H1 x 4	
M6 x 60mm	
H2 x 4	
H3 x 4	

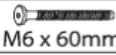

STEP 2

Now get the two front legs (P2) and connect it to the chair seat frame with corresponding hardware

H1 x 4	
M6 x 60mm	
H2 x 4	
H3 x 4	

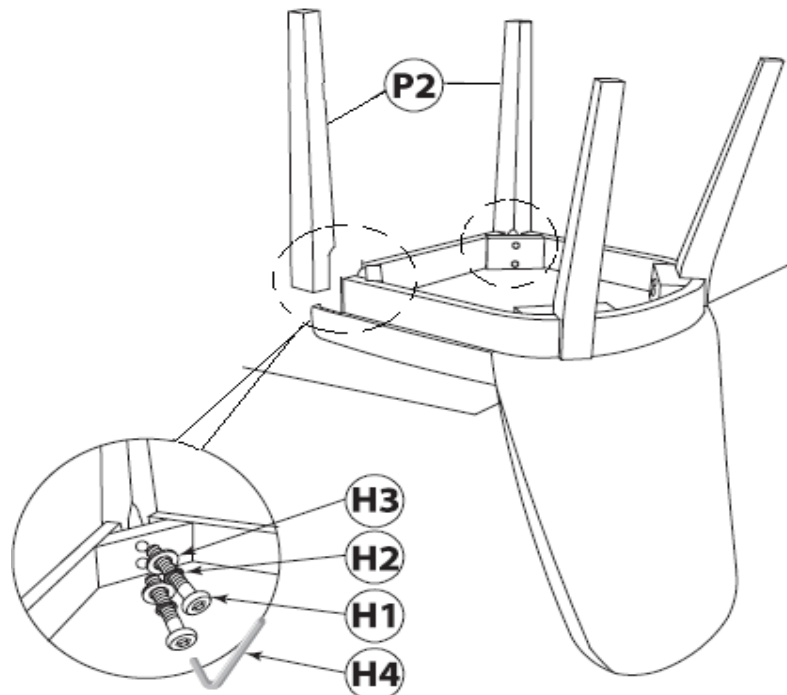

CARE AND MAINTENANCE

- SAFETY** - To avoid any risk of suffocation to children or animals, dispose off the plastic bags immediately.
- CLEANING** - Clean with damp cloth and mild detergent. Do not use bleach or abrasive products.
- FITTINGS** - Tighten bolts and nuts from time to time to ensure all parts of product are securely fitted.