

# ASSEMBLY INSTRUCTION

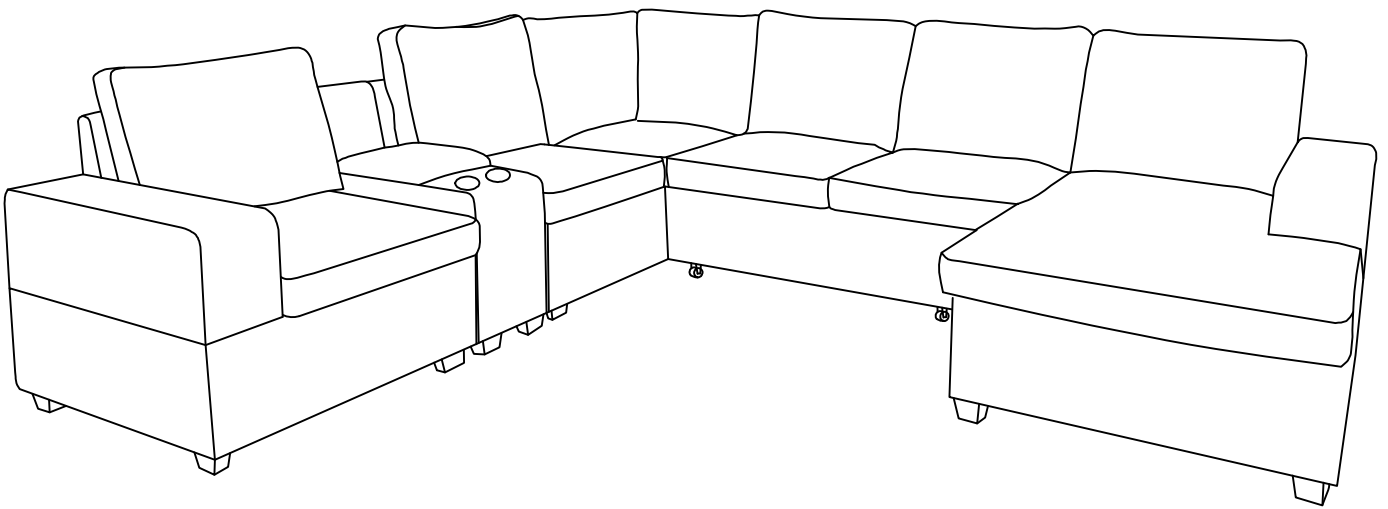

## Important Before You Start

This product is shipped in multiple cartons, which may arrive at different times. To ensure a smooth assembly process, please wait until all boxes have been delivered before opening and starting assembly. All necessary parts and hardware are distributed across the packages.

Please allow 72 hours for full expansion as air gradually fills the cushions after unpacking. Gently pat and fluff to help restore their full shape.

# Important Before You Start

Note: This sofa bed comes in three configuration options. The SKU and number of boxes you receive will depend on the option you purchased.

Before assembly, please refer to the diagrams below for the SKUs and number of boxes included with each configuration.

Please note that this product comes in multiple boxes that may arrive separately. If you find that any package is missing, please contact our customer service team for assistance.

Thank you for your understanding and support!

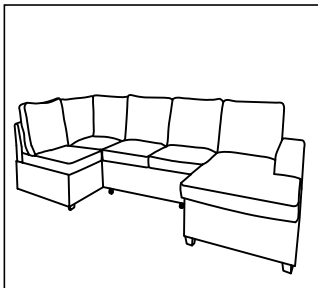

Option 1 includes :

YXSF-89018-A

YXSF-89018-C

YXSF-89018-D

Please refer to installation steps from page 7 to page 11

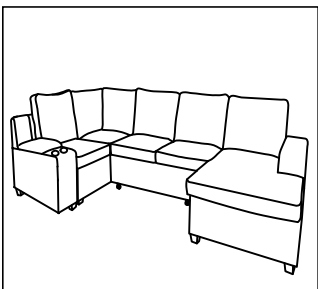

Option 2 includes :

YXSF-89018-A

YXSF-89018-C

YXSF-89018-D

YXSF-89018-Console

Please refer to installation steps from page 7 to page 11 , and page 13

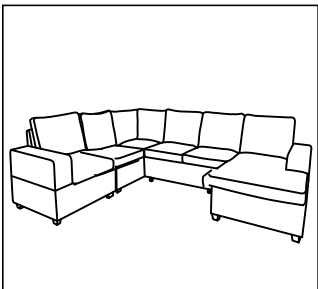

Option 3 includes :

YXSF-89018-A

YXSF-89018-B

YXSF-89018-C

YXSF-89018-D

Please refer to installation steps from page 7 to page 12 , and page 15

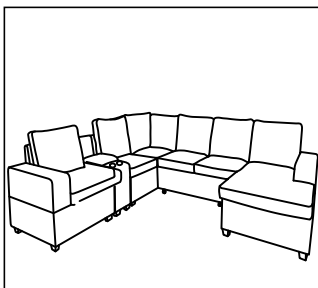

Option 4 includes :

YXSF-89018-A

YXSF-89018-B

YXSF-89018-C

YXSF-89018-D



YXSF-89018-Console





Please refer to installation steps from page 7 to page 13 , and page 16

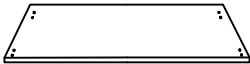
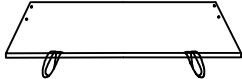

Scan the QR Code to Watch Assembly Video





# YXSF-89018-A

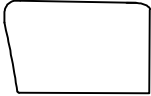
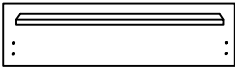

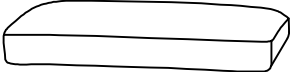
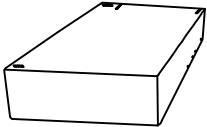
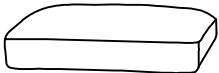

No.	DRAWING	DESCRIPTION	QTY
A		Loveseat Seat Base Panel	1
B		Pull-out Trundle Seat Panel	1
C		Rear Metal Connecting Bar	1
D		LAF Lovesaet Cushion 1/2	1

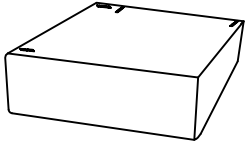
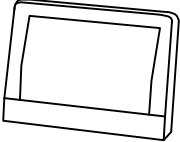
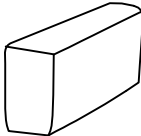
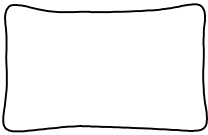
1	9	3	4
			
Washer X2	M8*20mm Bolt X2	8MM Allen Key X1	Corner Brakcet X2

E		RAF Corner Back Cushion	1
F		LAF Corner Back Cushion	1
G		Trundle Front Board	1
H1		RAF Chaise Cushion	1
H2		Trundle Seat Cushion	1
I		LAF Loveseat Frame	1
J		LAF Lovesaet Cushion 2/2	1

# YXSF-89018-B

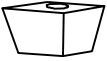





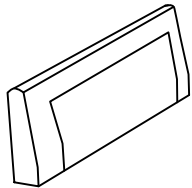
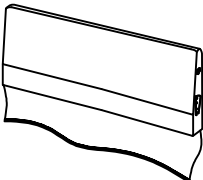

No.	DRAWING	DESCRIPTION	QTY
K		One-arm Chair Seat Frame	1
L		One-arm Chair Back Frame	1
M		One-arm Chair Arm (LAF)	1
N		One-arm Chair Back Cushion	1
O		One-arm Chair Seat Cushion	1

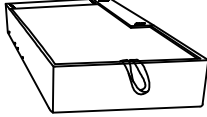



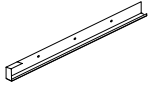
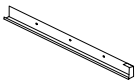

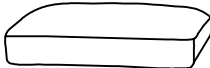
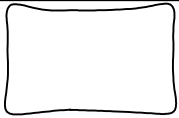

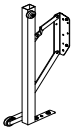
1  Washer X 4	2  M8*60mm Bolt X4	3  8MM Allen Key X1	5  Leg X4
6  Latch X4			

# YXSF-89018-C

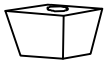





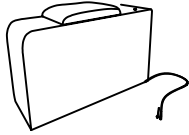
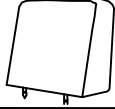

No.	DRAWING	DESCRIPTION	QTY
P		LAF Loveseat Back Frame	1
Q		Middle Lovesaet Back Frame	1

# YXSF-89018-D

No.	DRAWING	DESCRIPTION	QTY
R		RAF Chaise Frame	1
S		Arm	1
T		LAF Corner Backrest	1
U		RAF Corner Backrest	1
V1		LAF Pull-out Side Rail	1
V2		RAF Pull-out Side Rail	1
W		Supporting Bracket	4
X		Loveseat Cushion	2
Y		Back Cushion	4
Z1		LAF Pull-out Trundle Mechanism	1
Z2		RAF Pull-out Trundle Mechanism	1

1	 Washer X 18	2	 M8*60mm Bolt X4	3	 8MM Allen Key X1	5	 Leg X4
6	 Latch X4	7	 M6*20mm Bolt X10	8	 6MM Allen Key X1	9	 M8*20mm Bolt X14
10	 Velcro X8						

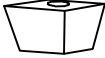
# YXSF-89018-Console

No.	DRAWING	DESCRIPTION	QTY
12		Console	1
13		Console Back Frame	1
1	 Washer X 4	2  M8*60mm Bolt X4	3  8MM Allen Key X1
9  M8*20mm Bolt X14	4  Corner Brakcet X2	5  Leg X4	11  Adapter X1

YXSF-89018BE-A  
YXSF-89018BE-C  
YXSF-89018BE-D

STEP 1

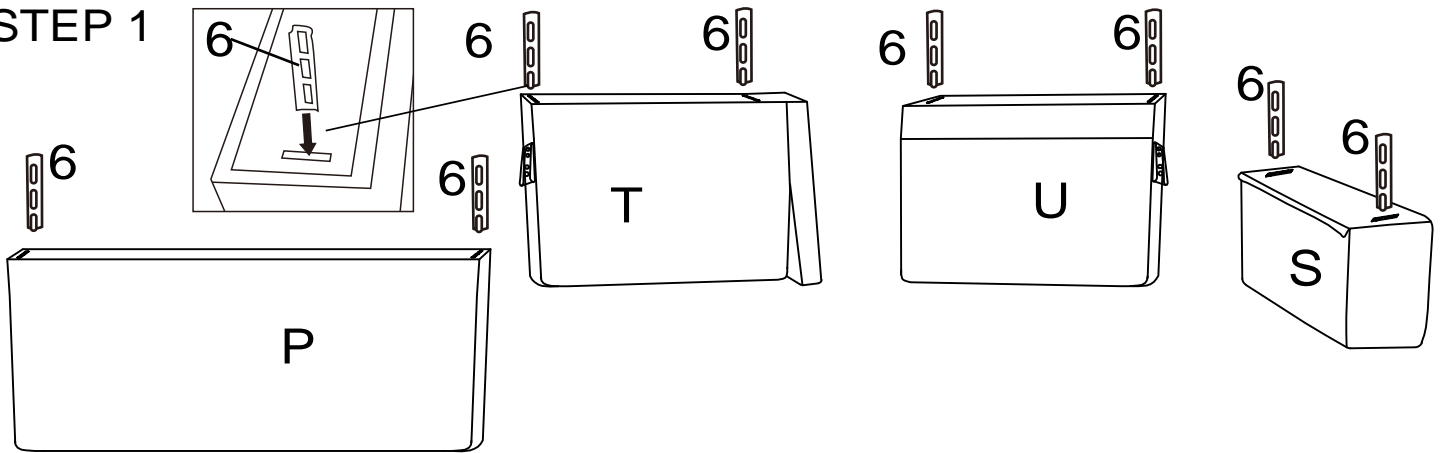

STEP 2

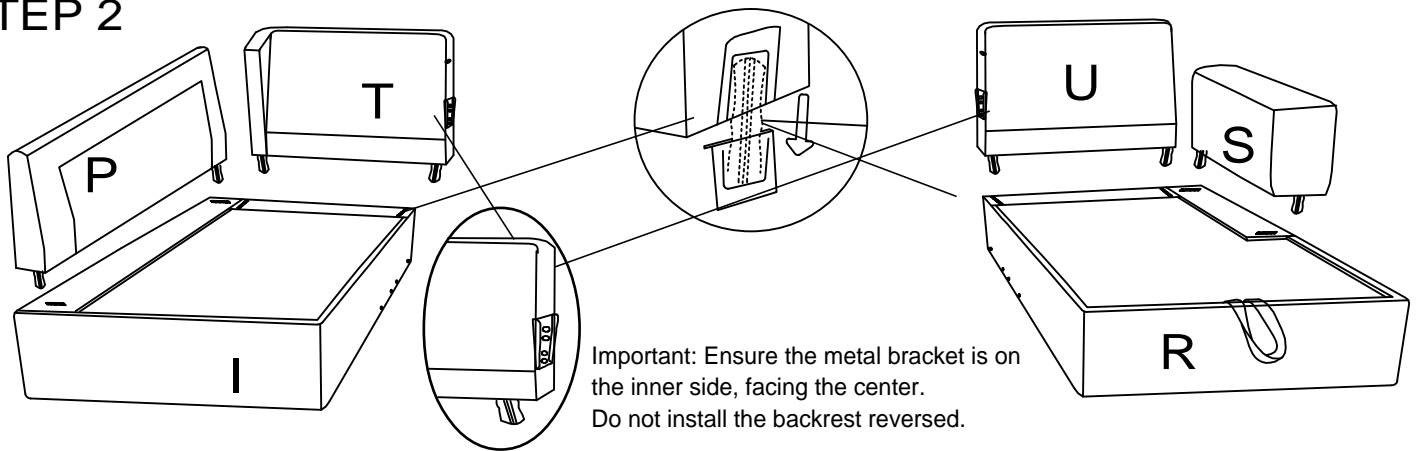

STEP 3

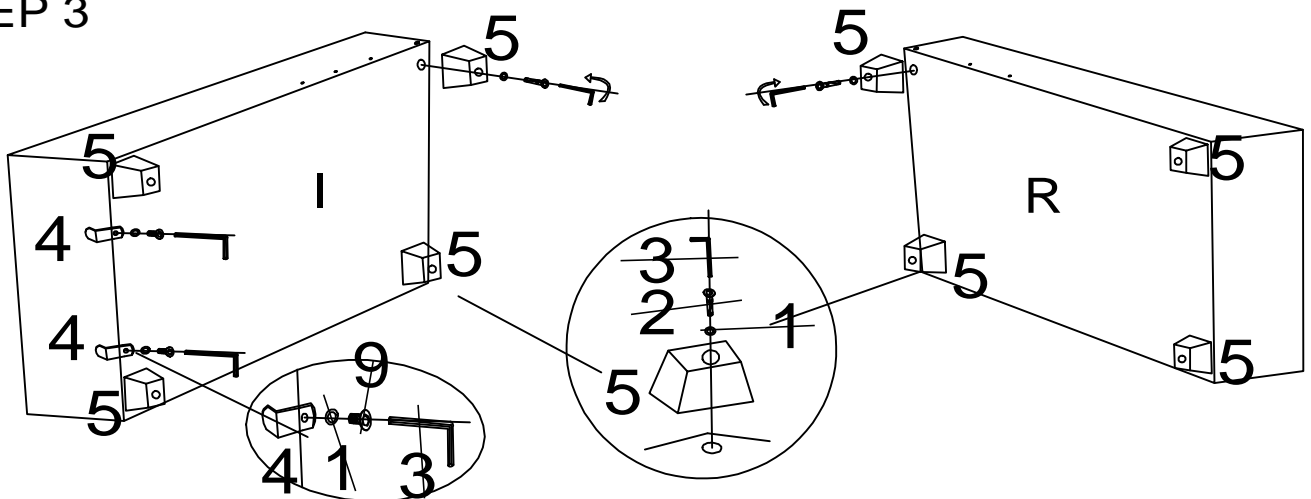

STEP 4

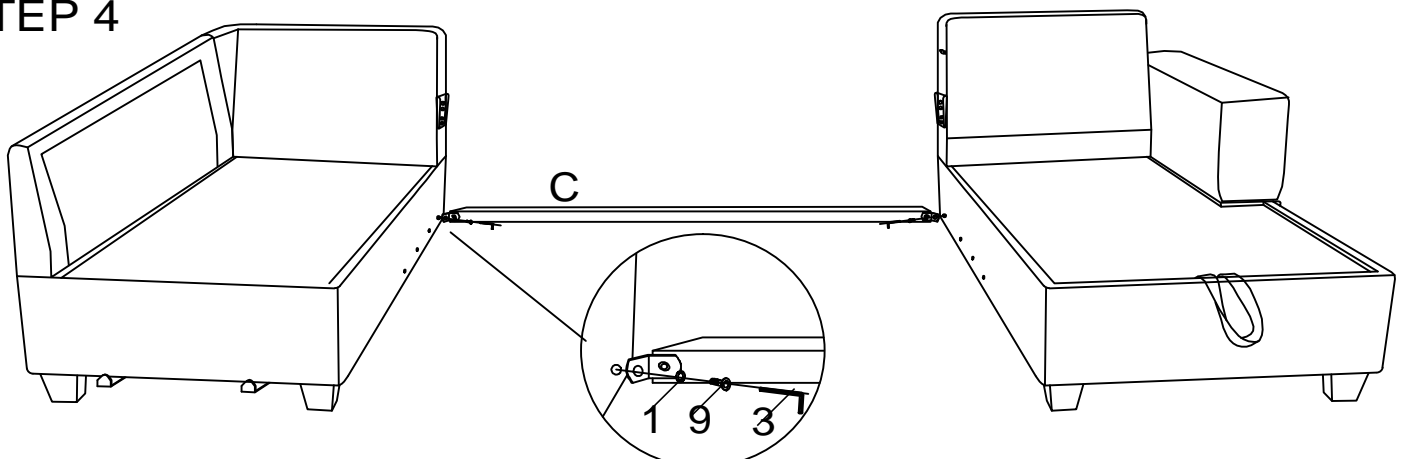

### STEP 5

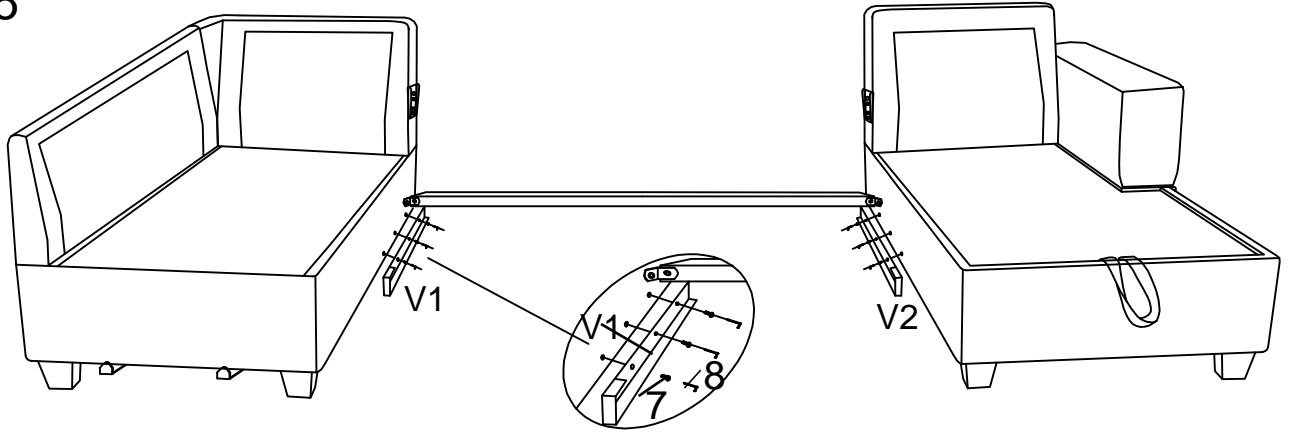

### STEP 6

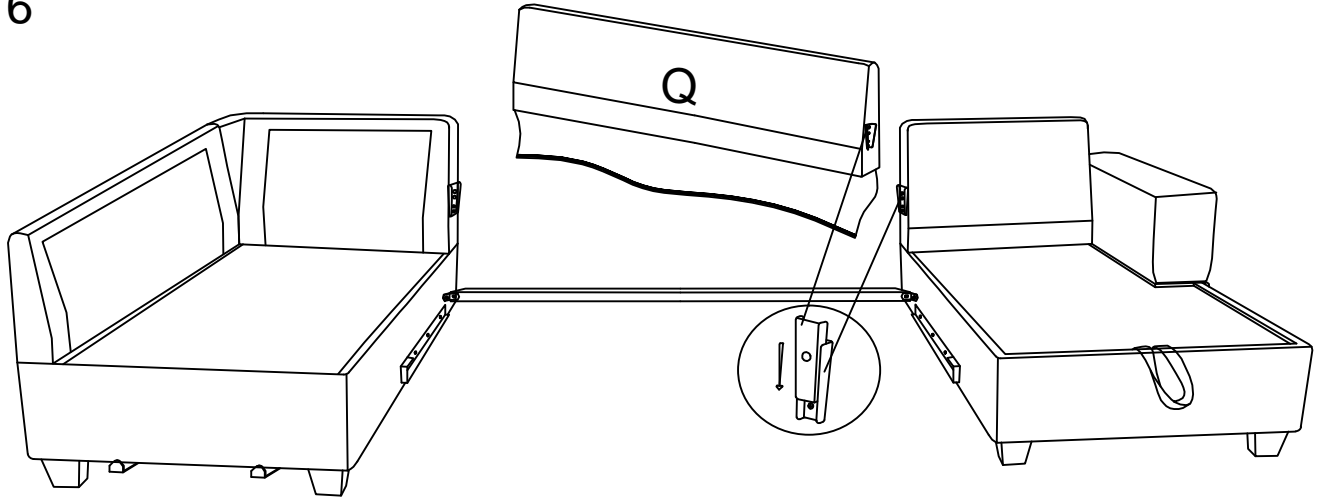

### STEP 7

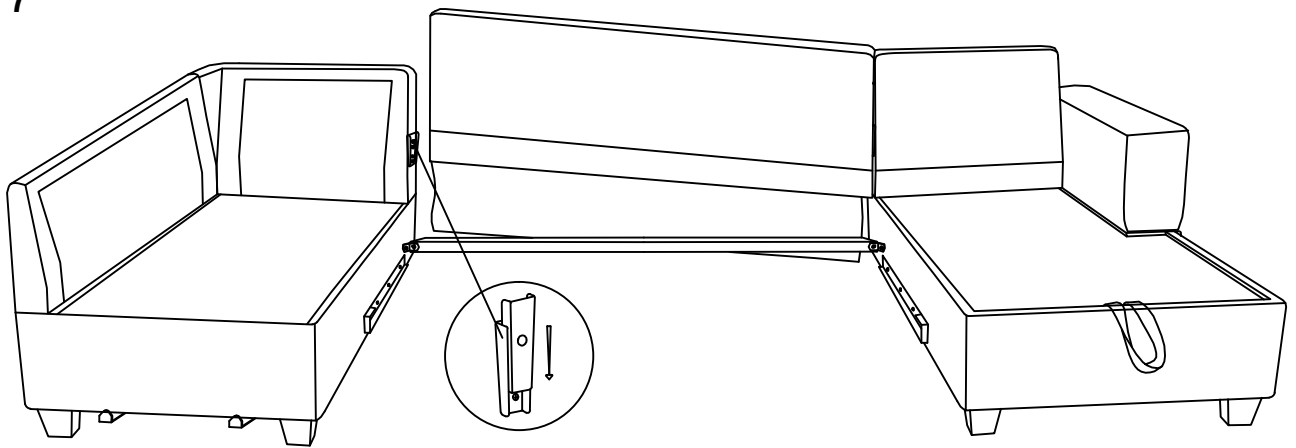

### STEP 8

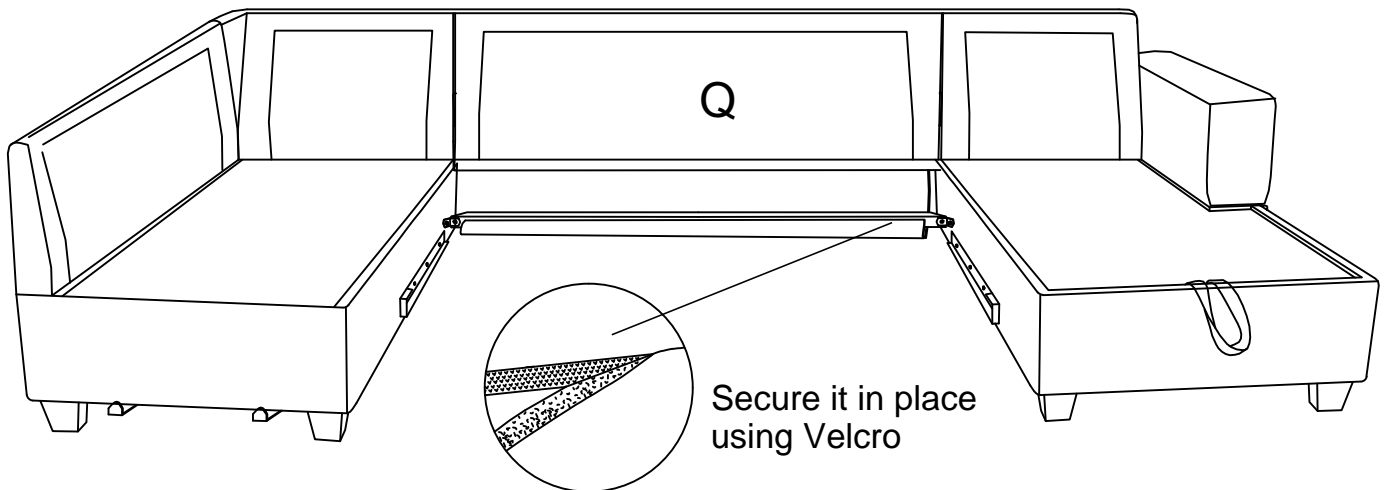

### STEP 9

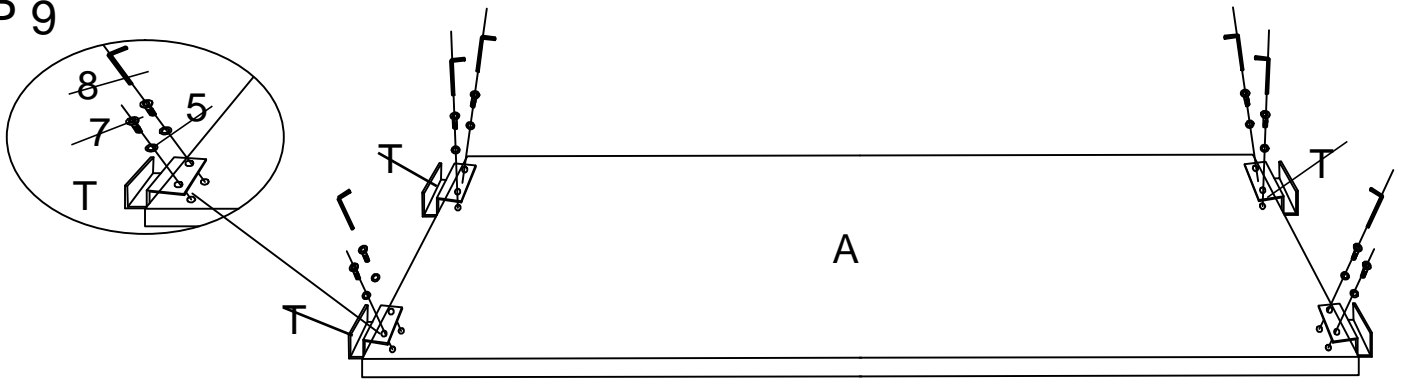

### STEP 10

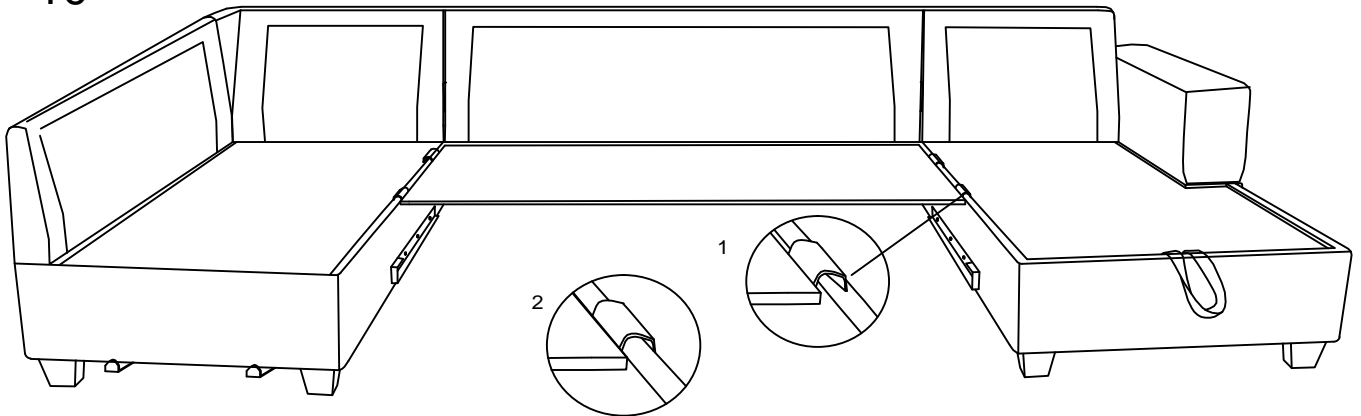

### STEP 11

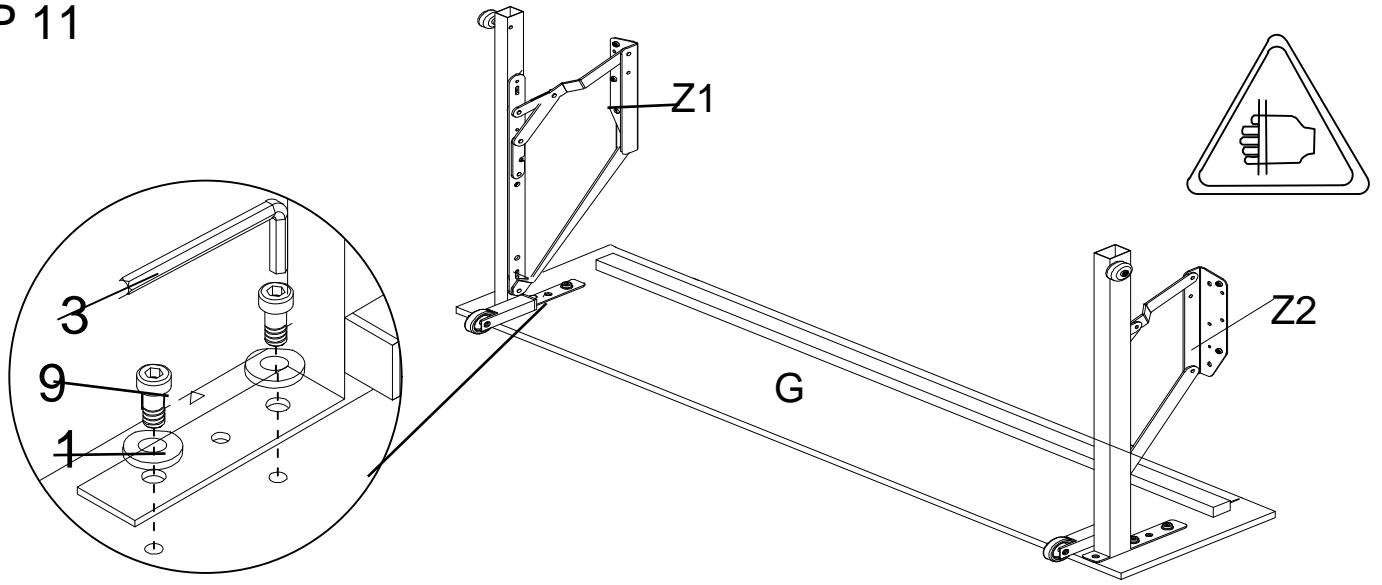

### STEP 12

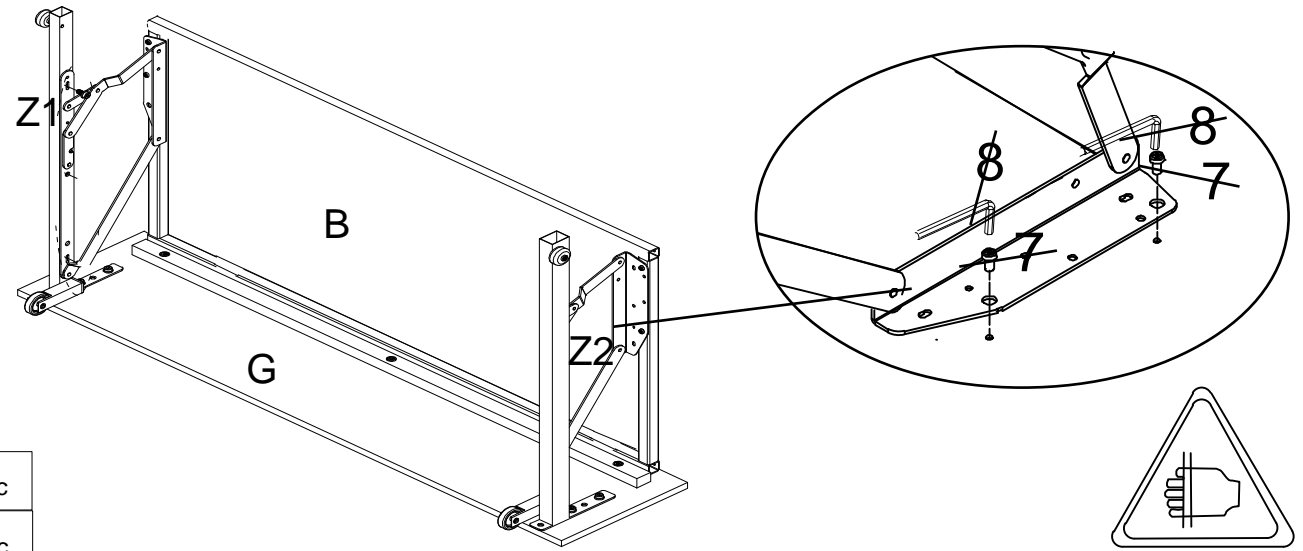

	7 x 4psc
	8 x 1psc

## STEP 13

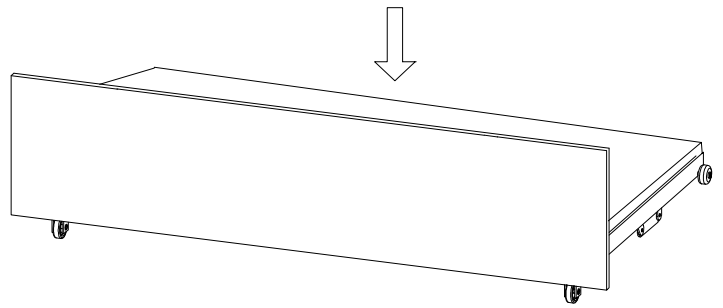
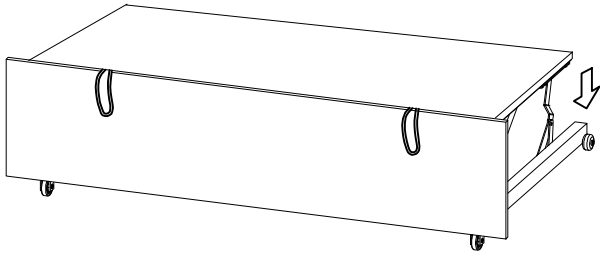

Place the trundle seat panel in the lowered position, then carefully slide the pull-out mechanism into the side rails until properly aligned.

## STEP 14

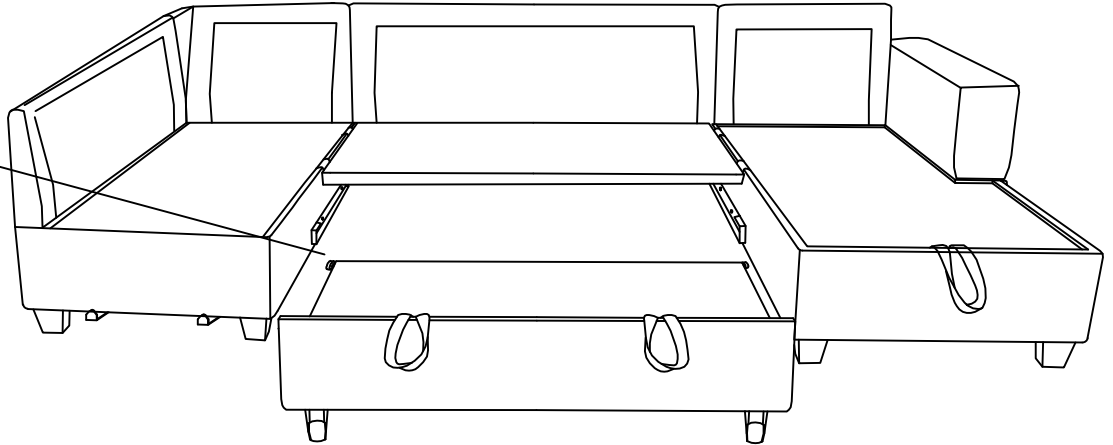
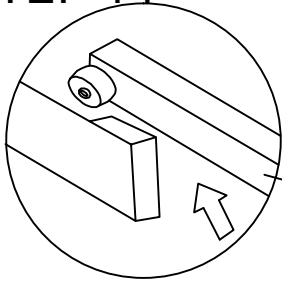

Tip: Ensure the seat panel is fully lowered before sliding the frame to avoid jamming.

## STEP 15

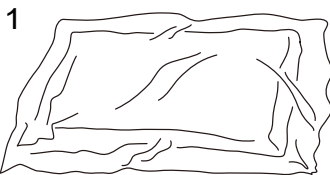
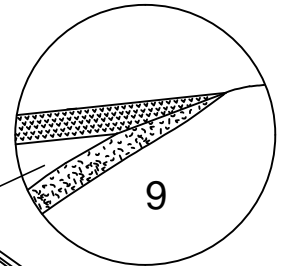
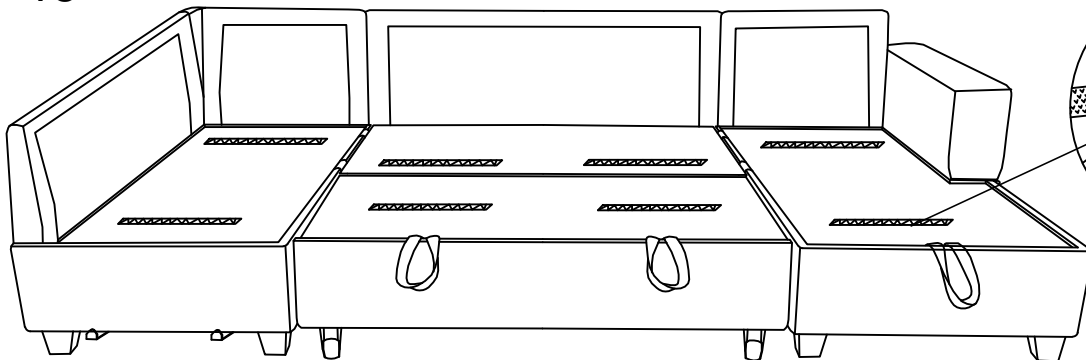

1  
Open the vacuum-sealed bag carefully. Avoid using sharp or pointed objects to prevent damaging the fabric.

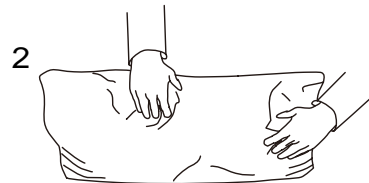

2  
Press and tap with both hands from the side to fully inhale air

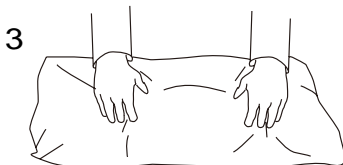

3  
Press and tap with both hands from the front to fully inflate.

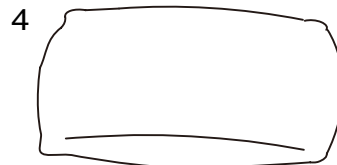

4  
Carefully smooth out each section until the surface is even.

After packing up, place them in somewhere dry and ventilated. After about 72-96hours. it can be restored to the best use condition.

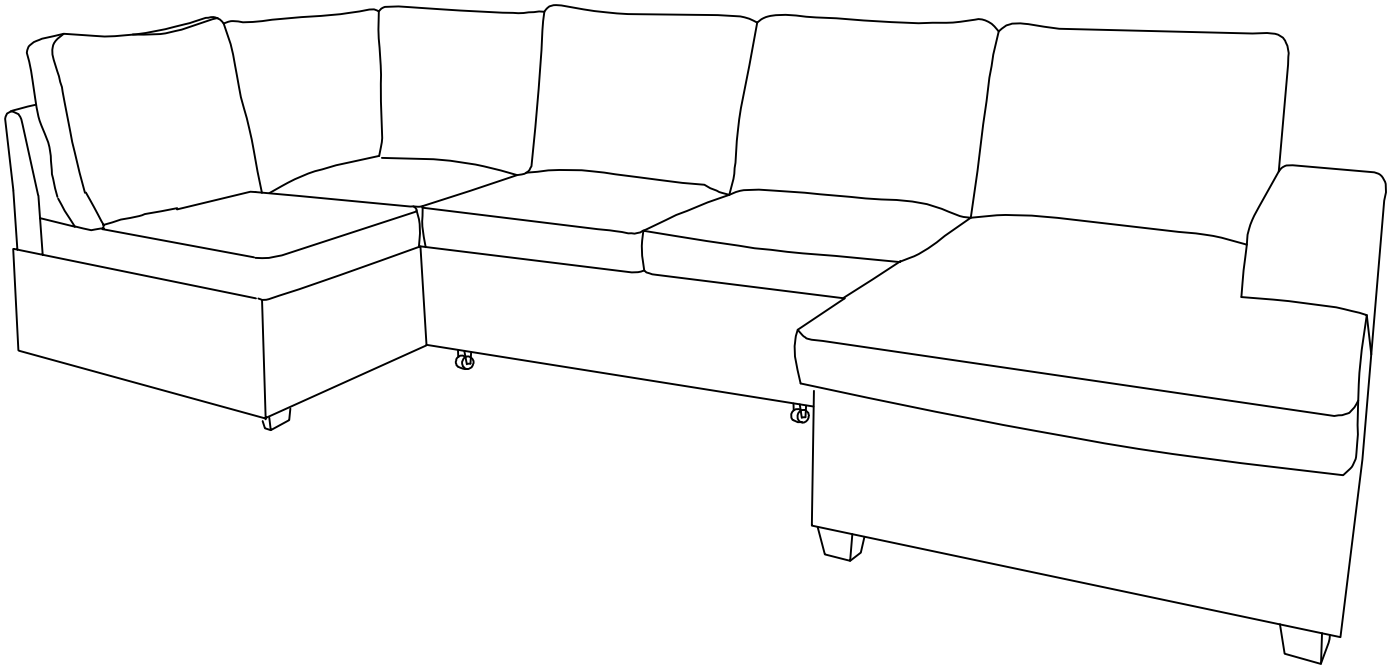
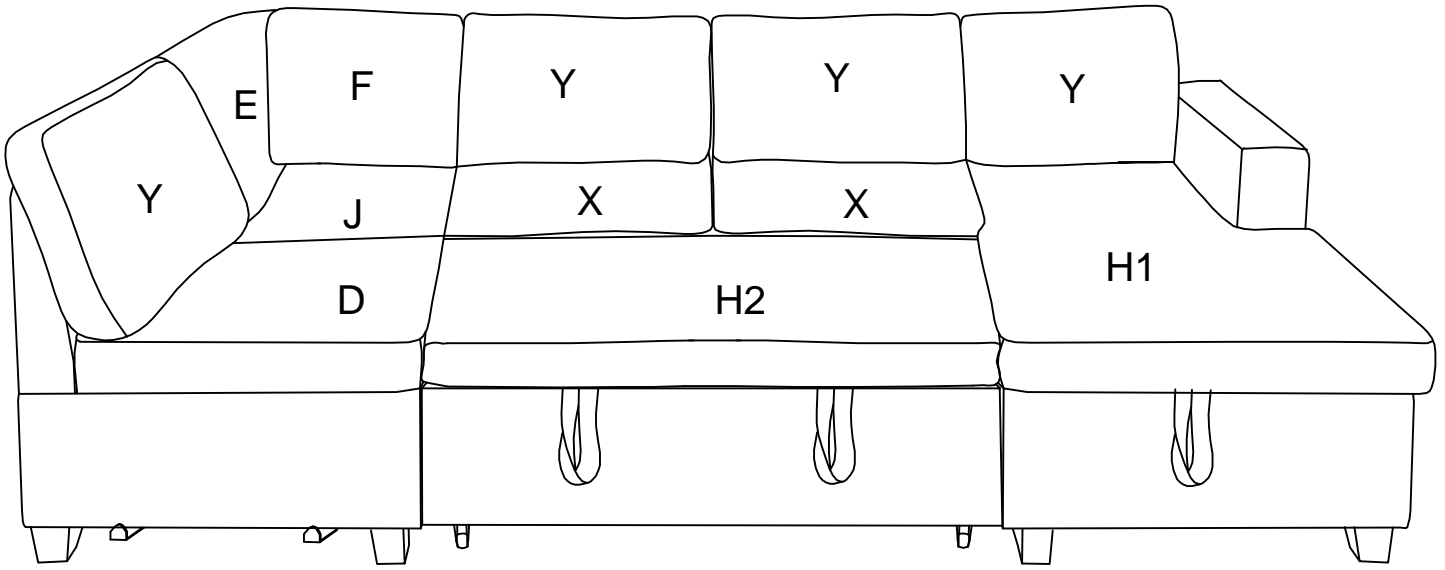

STEP 1

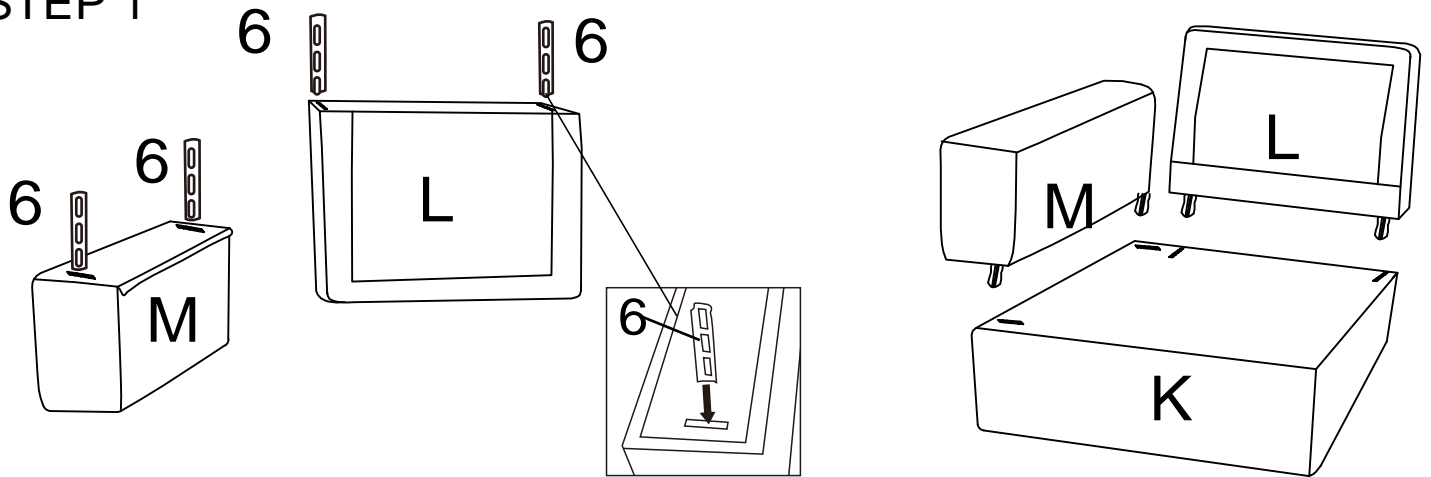

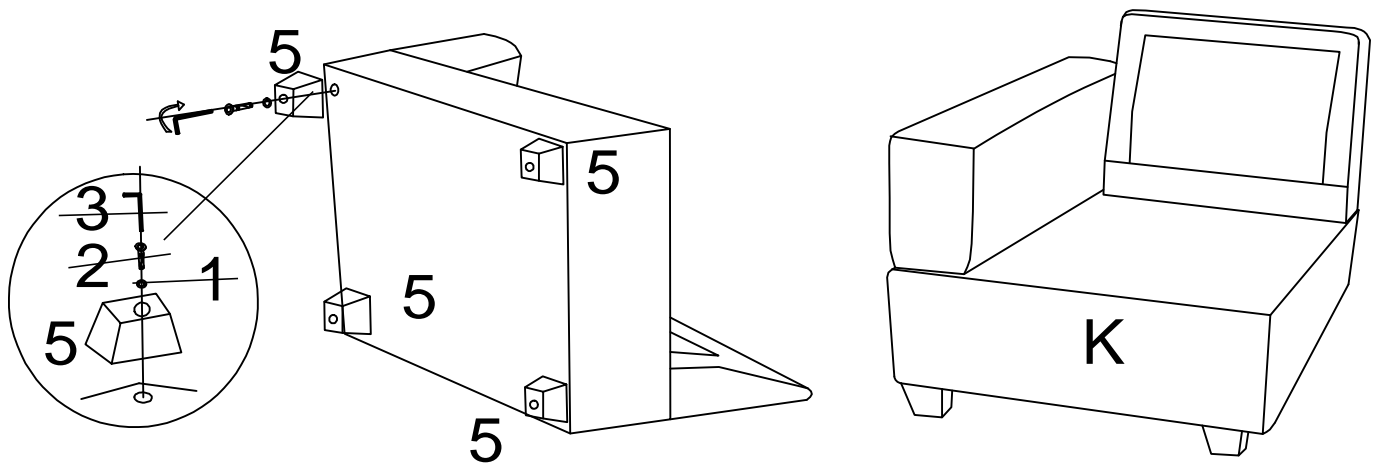

STEP 2



STEP 3

1  
  
 Open the vacuum-sealed bag carefully. Avoid using sharp or pointed objects to prevent damaging the fabric.

2  
  
 Press and tap with both hands from the side to fully inhale air

3  
  
 Press and tap with both hands from the front to fully inflate.

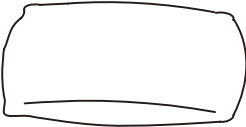
4  
  
 Carefully smooth out each section until the surface is even.

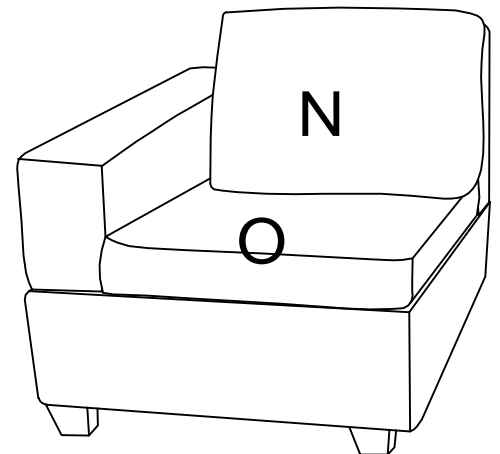

After packing up, place them in somewhere dry and ventilated. After about 72-96hours. it can be restored to the best use condition.

# YXSF-89018BE-Console

## STEP 1

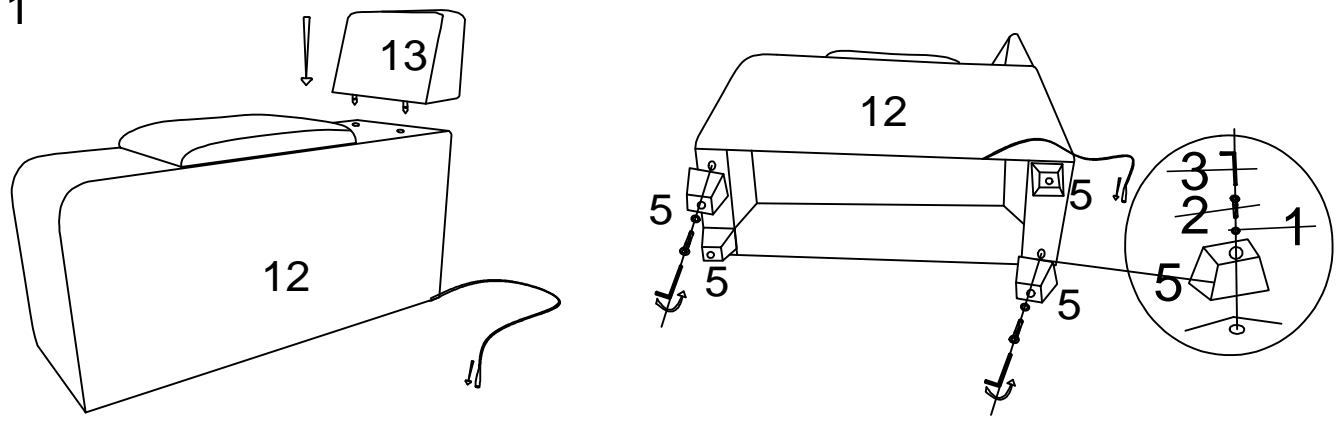

## STEP 2

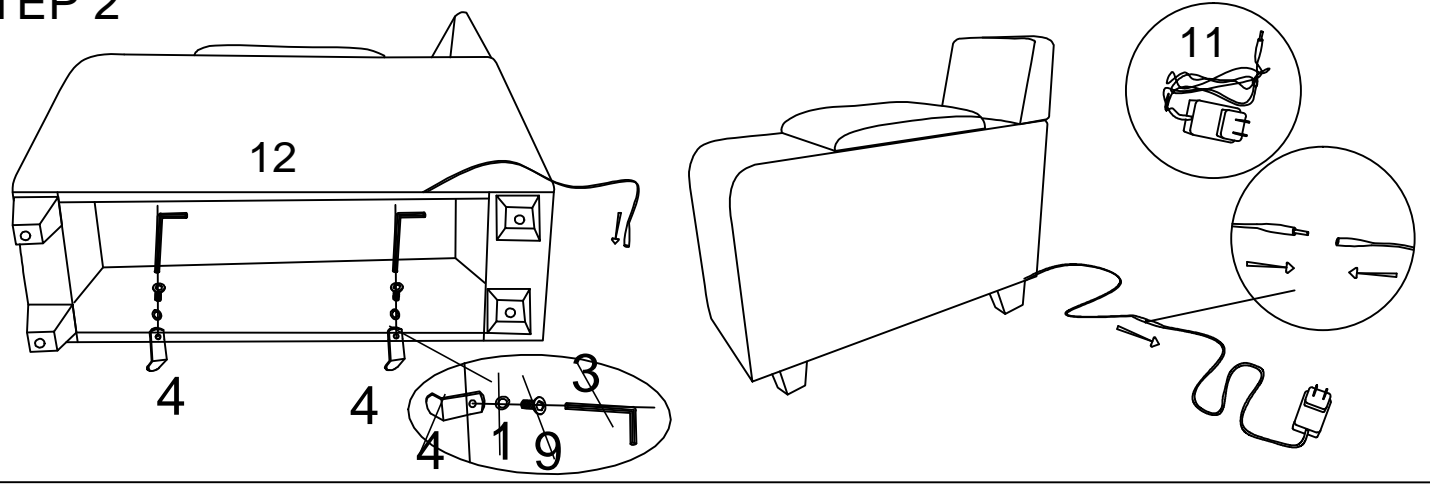

# STEP 16

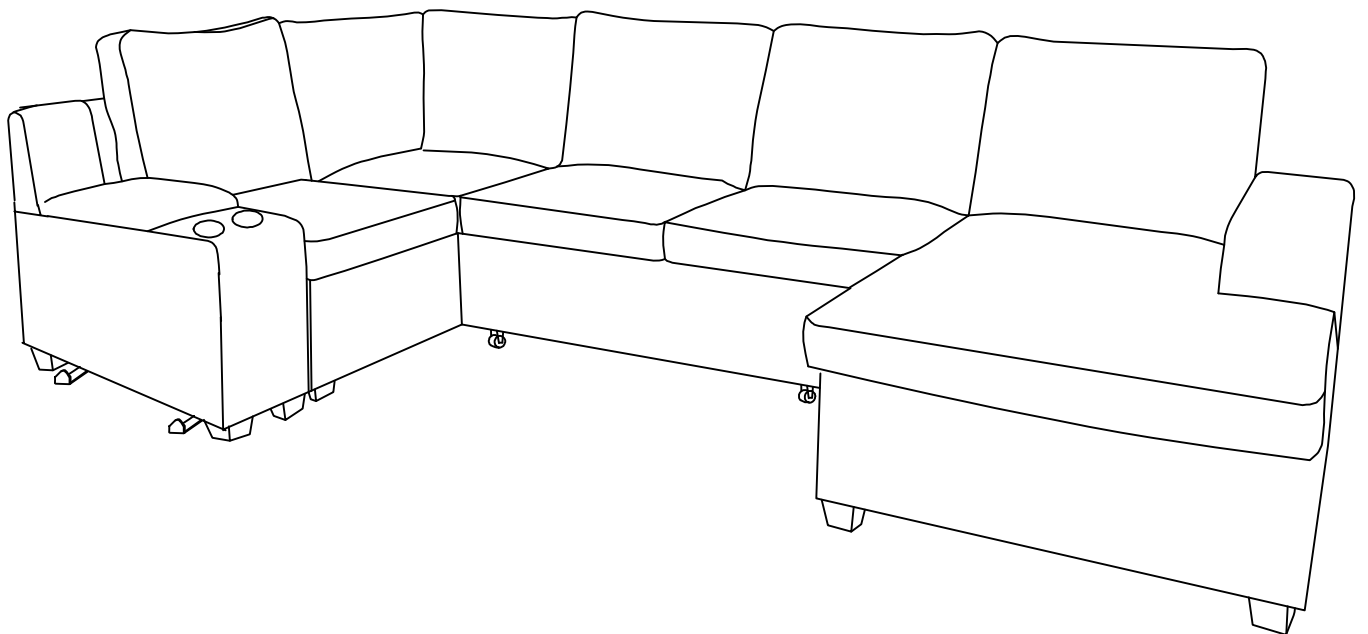
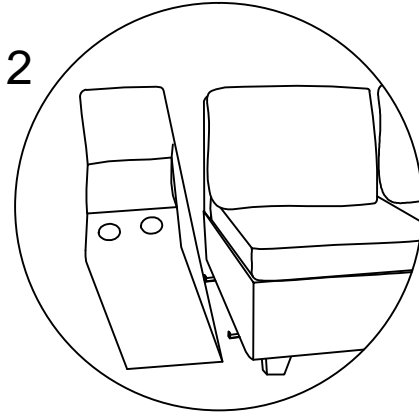
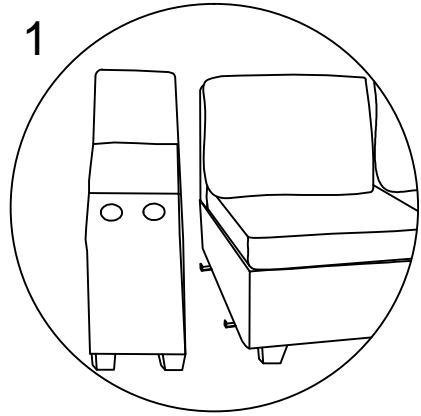
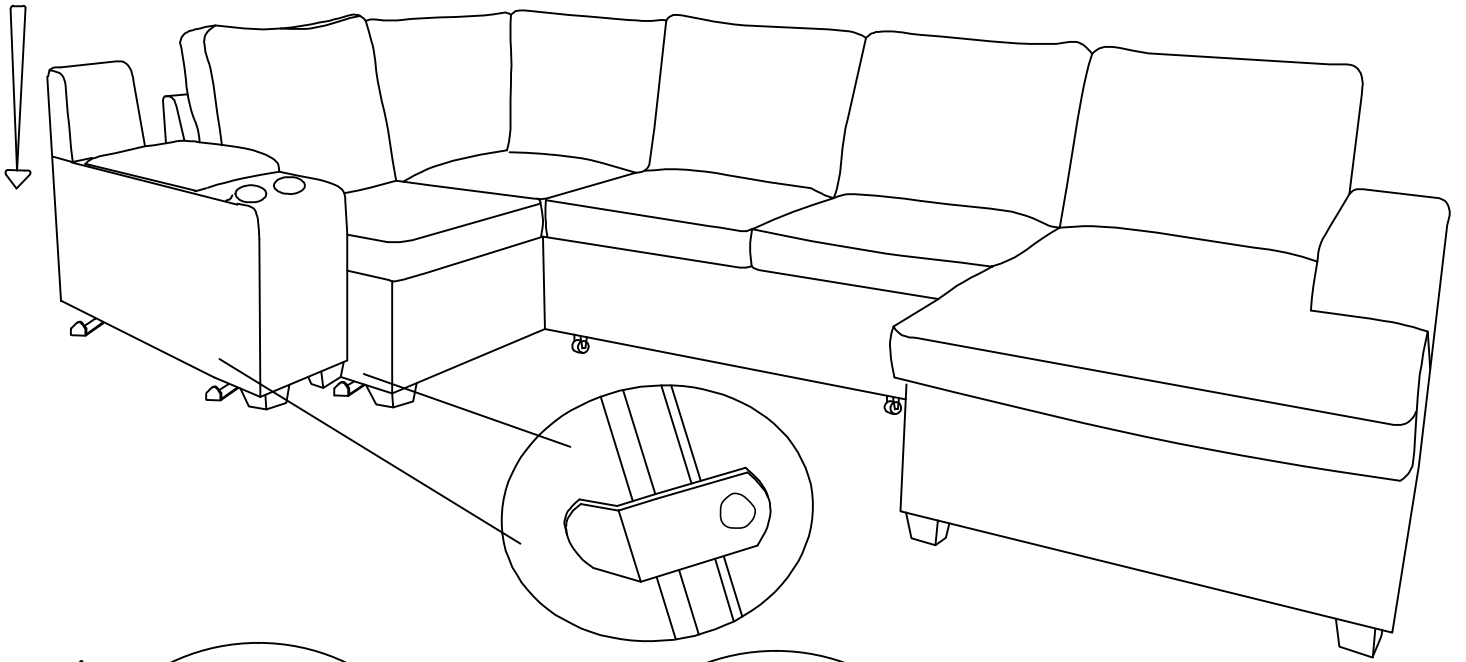

# STEP 4

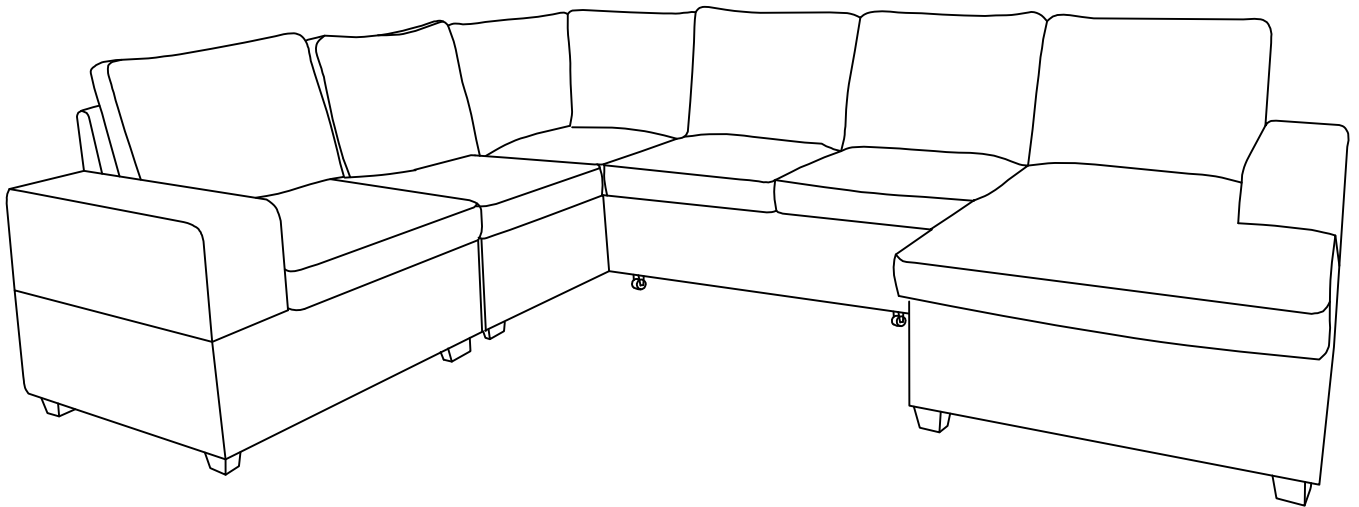
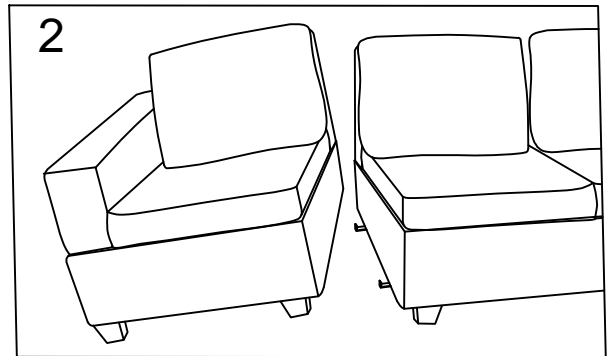
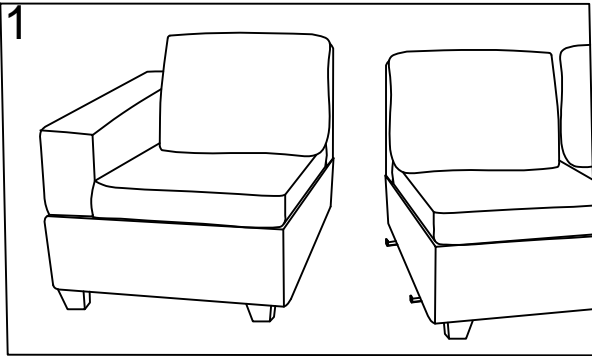
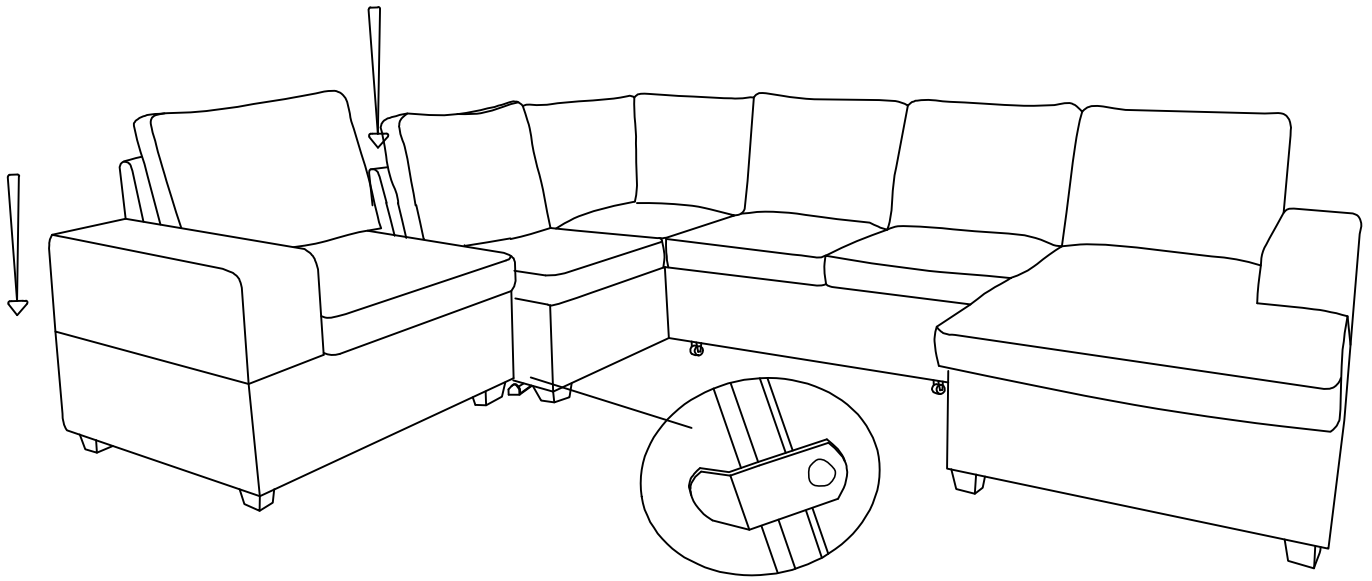

STEP 16

