

ASSEMBLY INSTRUCTIONS

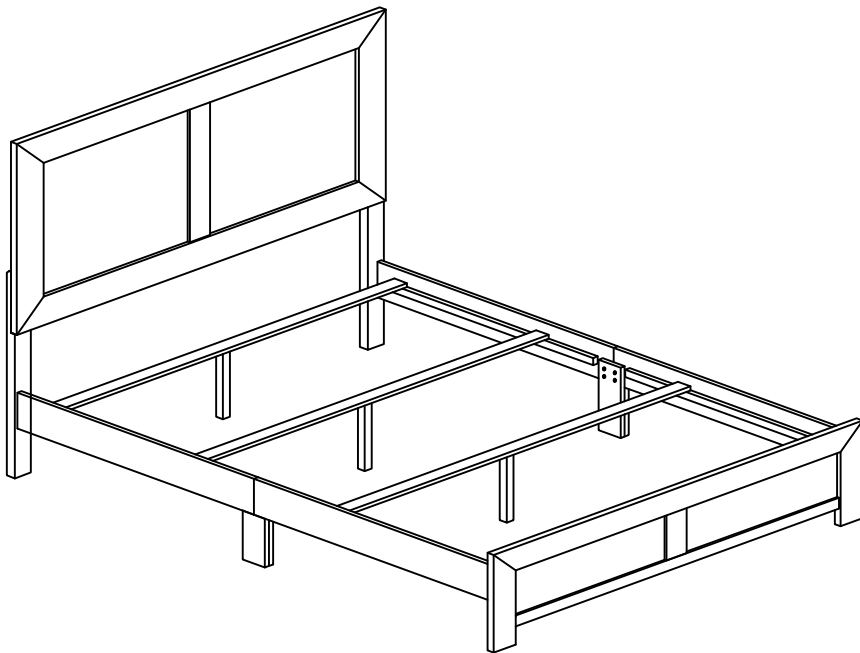

TOOLS REQUIRED



Allen Wrench

(Included)



Phillips
Screwdriver

(Not Included)



2 - People
Recommended

ASSEMBLY RATING

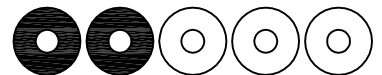

EASY ————— DIFFICULT

The Assembly Rating is a 5-point system showing the level of effort needed to assemble a specific product.

QUEEN BED



- Please keep instructions for future reference.
- Check the quantity and irregularity of parts and hardware before you start.

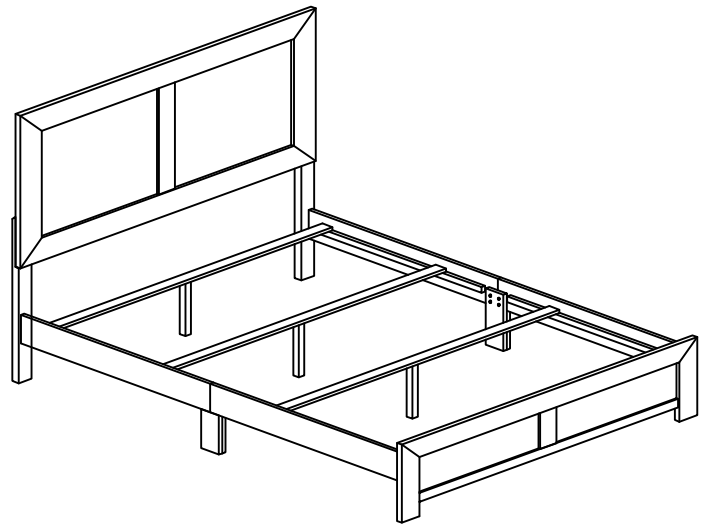

PARTS

#1 1pc

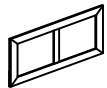

Headboard

#2 2pcs

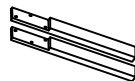

Headboard Leg
- L & R

#3 1pc

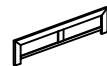

Footboard

#4 4pcs



Side Rail

#5 2pcs



Side Rail
Support Leg

#6 4pcs



Bed Slat

#7 4pcs



Slat Support
29 x 29 x 276 (mm)

HARDWARE

#A 6pcs

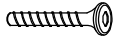

JCBB Bolt - M8 x 40 mm

#B 6pcs



Spring Washer - M8

#C 6pcs



Flat Washer - M8

#D 1pc



Allen Key - M5

#E 8pcs



JCBB Bolt - M8 x 16 mm

#F 8pcs



JCBC Bolt - M6 x 35 mm

#G 4pcs

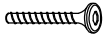

JCBC Bolt - M6 x 40 mm

#H 12pcs



Spring Washer - M6

#I 8pcs



Flat Washer - M6

#J 8pcs



CSK Screw - M4 x 32 mm

#K 1pc



Allen Key - M4

ASSEMBLY INSTRUCTIONS

1

- Part #1 x1pc
- Part #2 x2pcs
- Hardware #A x6pcs
- Hardware #B x6pcs
- Hardware #C x6pcs
- Hardware #D x1pc

Align HB legs (#2R/L) to the headboard (#1), then secure by using bolts (#A) with washers (#B,C).

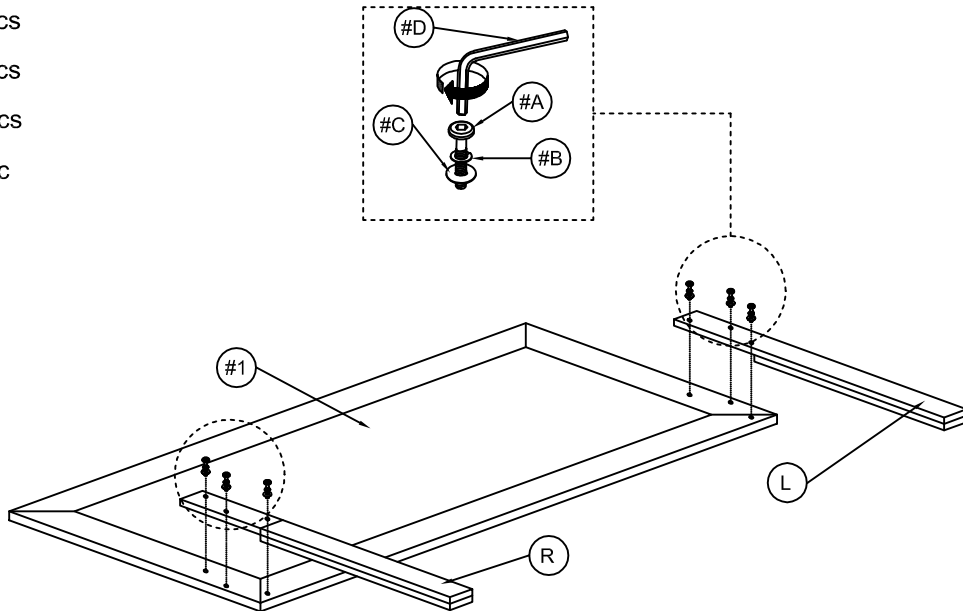

2

- Part #4 x4pcs
- Part #5 x2pcs
- Hardware #F x8pcs
- Hardware #H x8pcs
- Hardware #I x8pcs
- Hardware #K x1pc

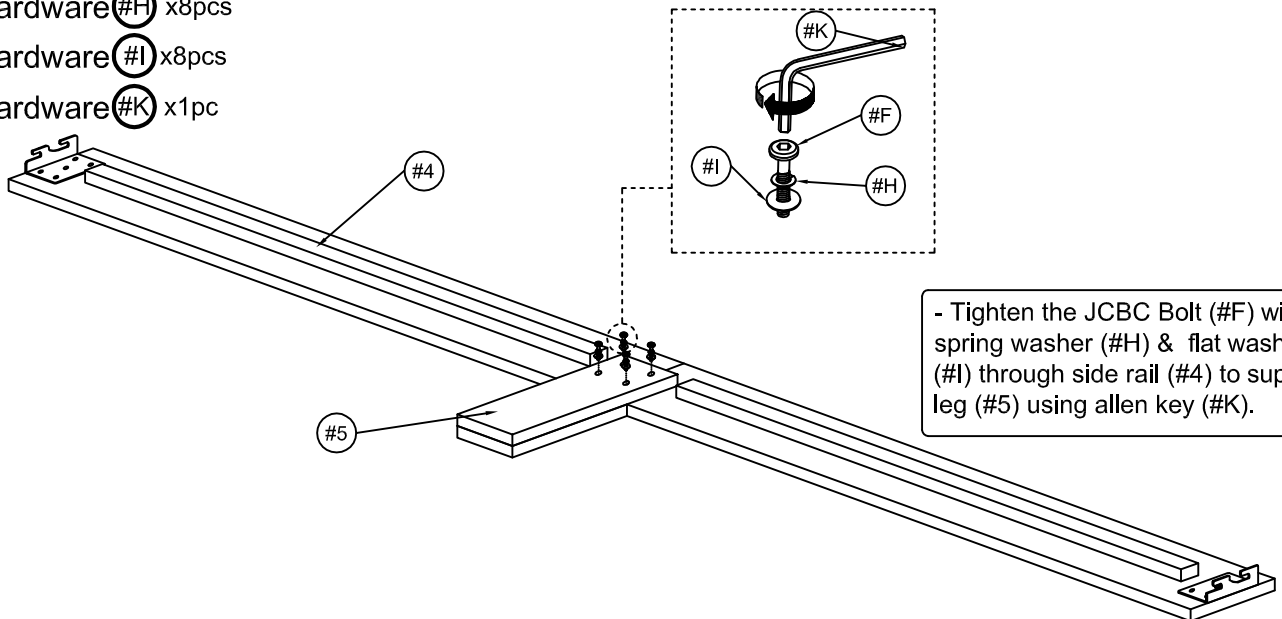

- Tighten the JCBC Bolt (#F) with spring washer (#H) & flat washer (#I) through side rail (#4) to support leg (#5) using allen key (#K).

ASSEMBLY INSTRUCTIONS

3

- Part #1 x1pc
- Part #3 x1pc
- Hardware #E x8pcs

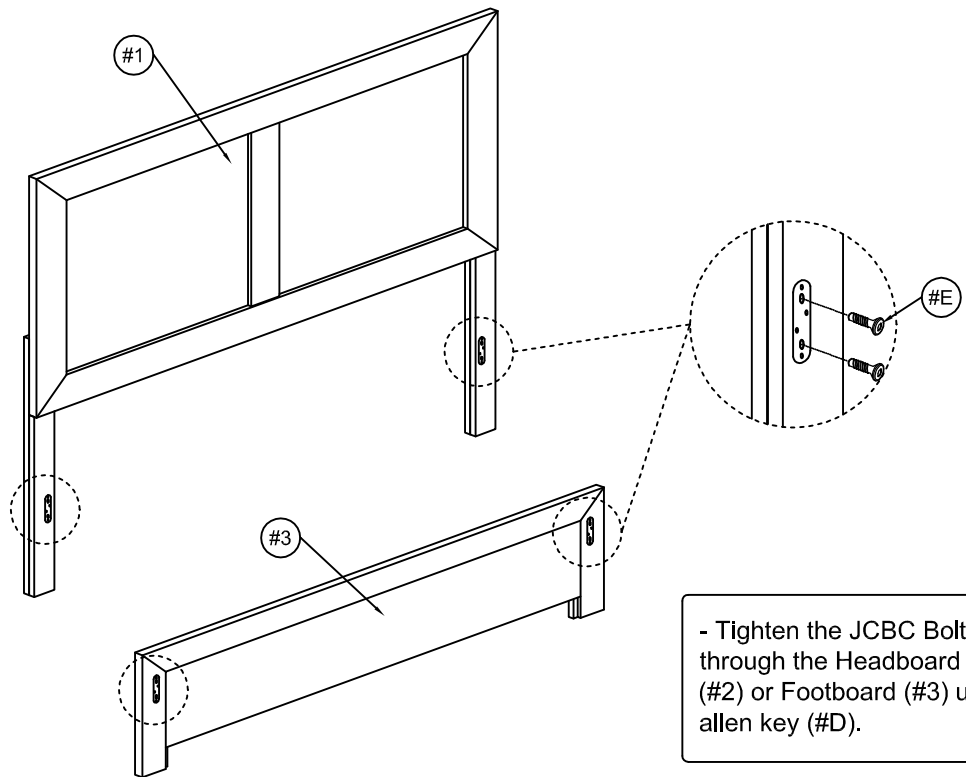

4

- Part #1 x1pc
- Part #3 x1pc
- Part #4 x4pcs
- Hardware #D x1pc

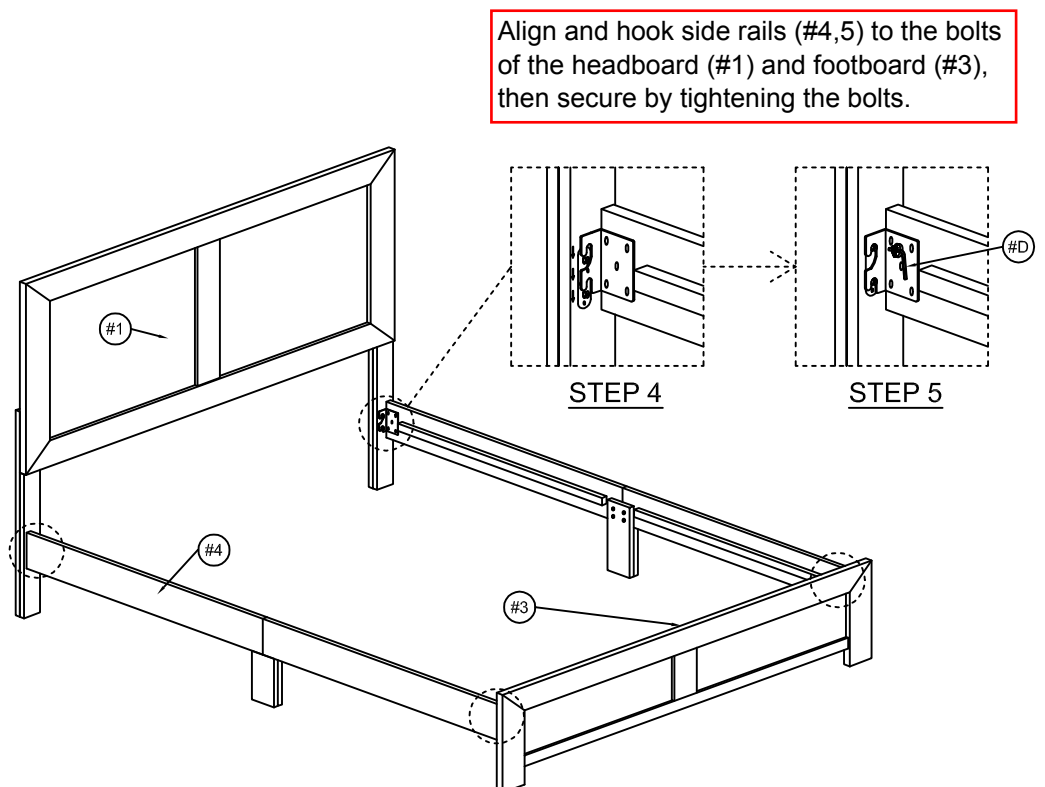

ASSEMBLY INSTRUCTIONS

5

- Part #6 x4pcs
- Part #7 x4pcs
- Hardware #G x4pcs
- Hardware #H x4pcs
- Hardware #K x1pc

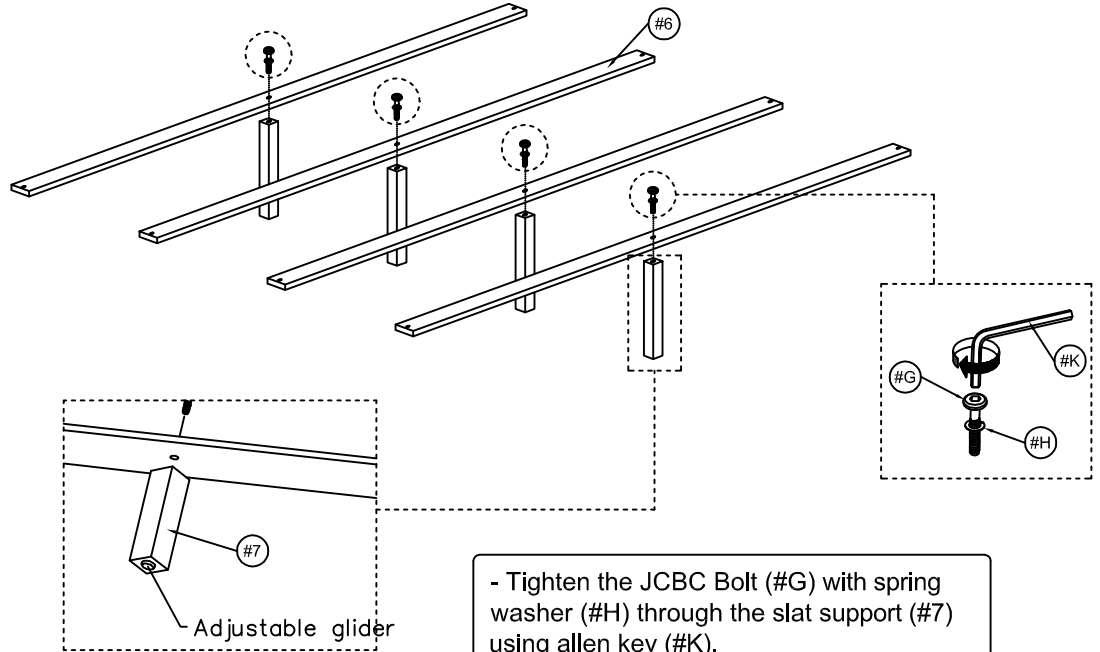

- Tighten the JCBC Bolt (#G) with spring washer (#H) through the slat support (#7) using allen key (#K).

NOTE: THE SETUP MUST BE DONE AT THE DECIDED LOCATION FOR THE BED TO OBTAIN PERFECT STABILITY

6

- Part #6 x4pcs
- Hardware #J x8pcs

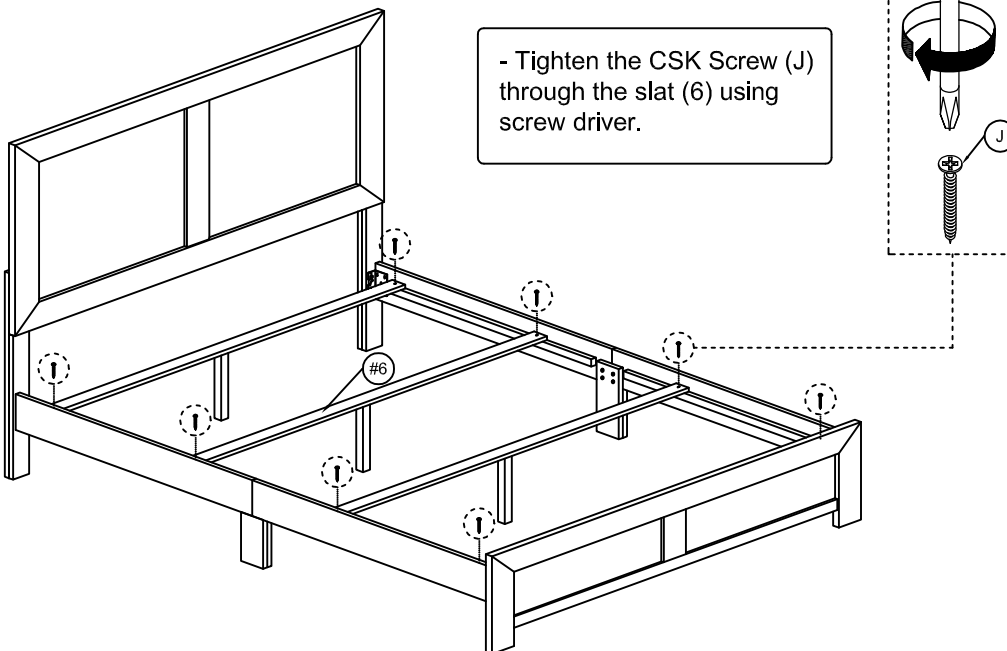

- Tighten the CSK Screw (J) through the slat (6) using screw driver.

ASSEMBLY COMPLETED



Please ensure the furniture rests on an even and flat surface. If the product wobbles or feels loose, double-check all bolts and/or screws are properly tightened and secured.

✓ Keep this handy!

Please retain this instruction manual and any order-related information for future reference.

✓ Lift, don't drag!

To avoid damage to product please always LIFT the product when transporting or adjusting the placement.