

# Bed frame

Cadre de lit

Bettrahmen

Struttura del letto

Bastidor de camas

ベッドフレーム

床架



## ASSEMBLY INSTRUCTION

Montageanleitung

Instructions De Montage

Istruzioni Per L'assemblaggio

Instrucciones De Montaje

組立説明書

安装说明书



## HELPFUL HINTS

### BEFORE YOU START

- Inspect product packaging to ensure the appearance is good.
- Read the assembly instruction carefully and follow it step by step.
- To avoid any scratching, putting a soft blanket on the floor is suggested.
- Identify, sort and count all the parts with tags.
- Find out installation position according to the drawing and install it in correct steps.

### OTHER

- People needed for assembly: 1-2.
- Estimated assembly time: 0.5-1h.

### CAUTION

- Be cautious when using a power drill or power screwdriver.
- Please be aware to slow down and stop when screw is nearly tight.
- Do Not use any harsh chemicals or abrasive cleaners for this item.
- Push, pull or drag this item carefully.

## ASTUCES UTILES

### AVANT DE COMMENCER

- Inspectez l'emballage du produit pour vous assurer que l'apparence est bonne.
- Lisez attentivement les instructions de montage et suivez-les étape par étape.
- Pour éviter toute rayure, posez une couverture douce sur le sol est suggéré.
- Identifiez, triez et comptez toutes les pièces avec des étiquettes.
- Trouver la position d'installation selon le dessin et l'installer dans les étapes correctes.

### AUTRE

- Personnes nécessaires pour l'assemblage : 1-2.
- Temps de montage estimé : 0.5-1h.

### AVERTIR

- Soyez prudent lorsque vous utilisez une perceuse électrique ou un tournevis électrique.
- Veuillez être conscient de ralentir et d'arrêter lorsque la vis est presque serrée.
- N'utilisez pas de produits chimiques corrosifs ou de nettoyeurs abrasifs pour cet article.
- Poussez, tirez ou tirez cet article avec précaution.

## CONSEJOS ÚTILES

### ANTES DE EMPEZAR

- Inspeccione el paquete del producto para asegurarse de que la apariencia es buena.
- Lea atentamente las instrucciones de montaje y sígalas paso a paso.
- Para evitar rayas, se sugiere poner una manta suave en el suelo.
- Identifique, clasifique y enumere todas las piezas con etiquetas.
- Averigüe la posición de instalación según el dibujo e instálela en los pasos correctos.

### OTROS

- Personas necesarias para el montaje: 1-2.
- Tiempo de montaje estimado: 0.5-1 h.

### PRECAUCIÓN

- Tenga cuidado al utilizar un taladro eléctrico o un destornillador eléctrico.
- Tenga en cuenta que debe hacerlo más despacio y detenerse cuando el tornillo esté casi apretado.
- No utilice productos químicos agresivos ni limpiadores abrasivos para este artículo.
- Empuje, tire o arrastre este elemento con cuidado.

## SUGGERIMENTI UTILI

### PRIMA DI INIZIARE

- Controllare la confezione del prodotto per assicurarsi che sia in buono stato.
- Leggere con attenzione le istruzioni per l'assemblaggio e seguirle passo dopo passo.
- Per evitare graffi al pavimento, suggeriamo di stendervi una coperta morbida.
- Identificare, suddividere e contare tutte le parti con etichetta.
- Trovare la posizione adatta per il montaggio in base al disegno e montare lo scaffale seguendo correttamente i vari passaggi.

### ALTRO

- Persone necessarie per l'assemblaggio: 1-2.
- Tempo di assemblaggio stimato: 0.5-1 ora.

### ATTENZIONE

- Prestare molta attenzione quando si utilizza un trapano elettrico o un cacciavite elettrico.
- Rallentare con accortezza e fermarsi quando una vite è già sufficientemente serrata.
- Non utilizzare prodotti chimici aggressivi o detergenti abrasivi su questo articolo.
- Spingere, tirare o trascinare questo articolo con cautela.

## NÜTZLICHE HINWEISE

### BEVOR SIE BEGINNEN

- Überprüfen Sie die Produktverpackung auf Schäden.
- Lesen Sie sich die Montageanleitung sorgfältig durch und befolgen Sie sie Schritt für Schritt.
- Um etwaiges Zerkratzen zu vermeiden, wird das Auslegen einer weichen Decke auf dem Boden empfohlen.
- Identifizieren, sortieren und zählen Sie alle Teile mit Tags nach.
- Identifizieren Sie die Montageposition gemäß der Zeichnung und bauen Sie das Regal den richtigen Schritten entsprechend auf.

### SONSTIGES

- Für den Zusammenbau erforderliche Anzahl an Menschen: 1-2.
- Ungefähre Montagedauer: 0.5-1 h.

### VORSICHT

- Seien Sie bei der Verwendung einer Bohrmaschine oder eines Akkuschraubers vorsichtig.
- Bitte vergessen Sie nicht darauf, langsamer zu werden und zu stoppen, sobald die Schraube fast festgezogen ist.
- Verwenden Sie keinerlei aggressive Chemikalien oder scheuernden Reinigungsmittel für dieses Produkt.
- Schieben oder ziehen Sie dieses Produkt vorsichtig.

## 温馨提示

### 安装前注意事项

- 检查产品包装，确保外观良好。
- 仔细阅读安装说明，按步骤操作。
- 为了避免刮伤，建议在地板上放一条柔软的毯子。
- 标识、分类和清点所有部件。
- 根据图形找到安装孔位，按正确步骤安装。

### 其他：

- 组装所需人员:1-2人。
- 预计组装时间: 0.5-1小时。

### 注意：

- 小心使用电钻或电动螺丝刀。
- 当螺丝快要拧紧时，请注意减速。
- 不要使用任何刺激性化学物质或擦洗剂。
- 当推、拉或拖动产品时，注意小心谨慎，防止损坏。

## 役に立つヒント

### 組立の場所を確保し、順番通りに組み立てる

- 組立場所（充分広くて平たい場 所）を確保してください。
- 床や壁、商品を傷つけないように、商品の下に厚めの布や段ボールなどを敷いてください。
- 組立の順番を守らないと、組立できなくなったり、商品を傷つけたりします。

### その他

- 組み立てに必要な人:1-2。
- 組立時間：約0.5~1時間。

### 部品を確認する

- ネジ類などの部品番号、形状を説明書の部品一覧で確認してください。
- 部品をなくさないように纏めて置いてください。
- 部品を取り出すときに使う分だけ取り出してください。

# ASSEMBLY INSTRUCTION

Montageanleitung

Instructions De Montage

Istruzioni Per L'assemblaggio

Instrucciones De Montaje

組立説明書



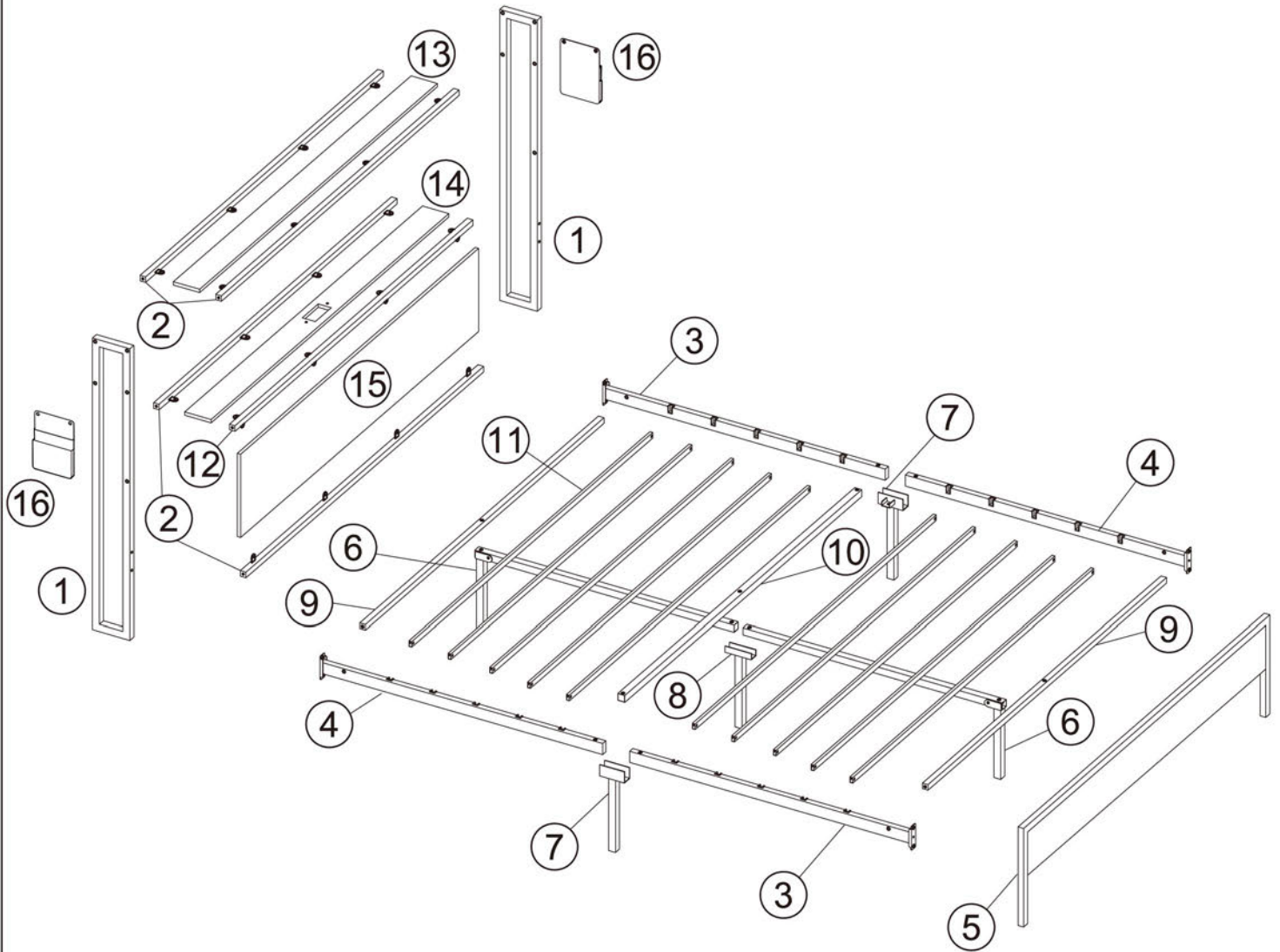









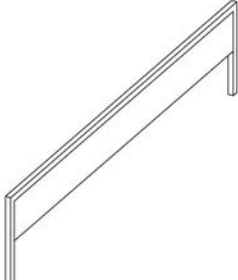

安装说明书

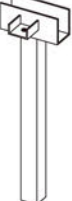
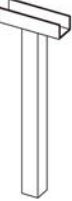

# PARTS LIST

Liste des pièces  
Teileliste  
Elenco dei componenti

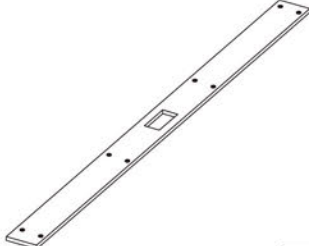
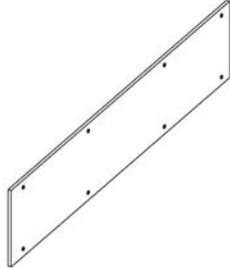









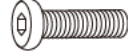

Lista de partes  
部品リスト  
零部作清單

<p>①</p>  <p>X2</p>	<p>②</p>  <p>X4</p>	<p>③</p>  <p>X2</p>
<p>④</p>  <p>X2</p>	<p>⑤</p>  <p>X1</p>	<p>⑥</p>  <p>X2</p>
<p>⑦</p>  <p>X2</p>	<p>⑧</p>  <p>X1</p>	<p>⑨</p>  <p>X2</p>
<p>⑩</p>  <p>X1</p>	<p>⑪</p>  <p>X10</p>	<p>⑫</p>  <p>X1</p>
<p>⑬</p>  <p>X1</p>	<p>⑭</p>  <p>X1</p>	<p>⑮</p>  <p>X1</p>
<p>⑯</p>  <p>X2</p>		

# PARTS LIST

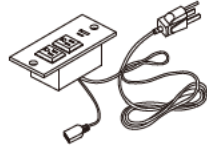
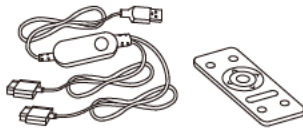

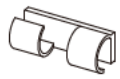
Liste des pièces  
Teileliste  
Elenco dei componenti

Lista de partes  
部品リスト  
零部件清单

<p>(A)</p>  <p>M8x60mm</p> <p>X3</p>	<p>(B)</p>  <p>M8x50mm</p> <p>X4</p>	<p>(C)</p>  <p>M8x35mm</p> <p>X18</p>	<p>(D)</p>  <p>M8x20mm</p> <p>X8</p>
<p>(E)</p>  <p>M6x12mm</p> <p>X24</p>	<p>(G)</p>  <p>M3x12mm</p> <p>X2</p>	<p>(H)</p>  <p>Ø17*8.5*2</p> <p>X7</p>	<p>(I)</p>  <p>M4</p> <p>X1</p>
<p>(J)</p>  <p>M5</p> <p>X1</p>	<p>(K)</p>  <p>X1</p>	<p>(P)</p>  <p>X1</p>	<p>(Q)</p>  <p>SHORT</p> <p>X1</p>
<p>(R)</p>  <p>LONG</p> <p>X1</p>	<p>(S)</p>  <p>X9</p>	<p>(Y)</p>  <p>X11</p>	

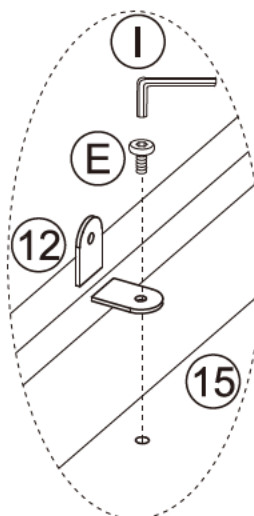
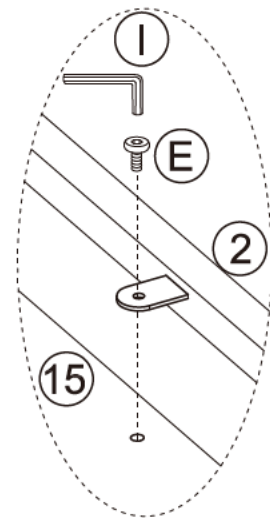
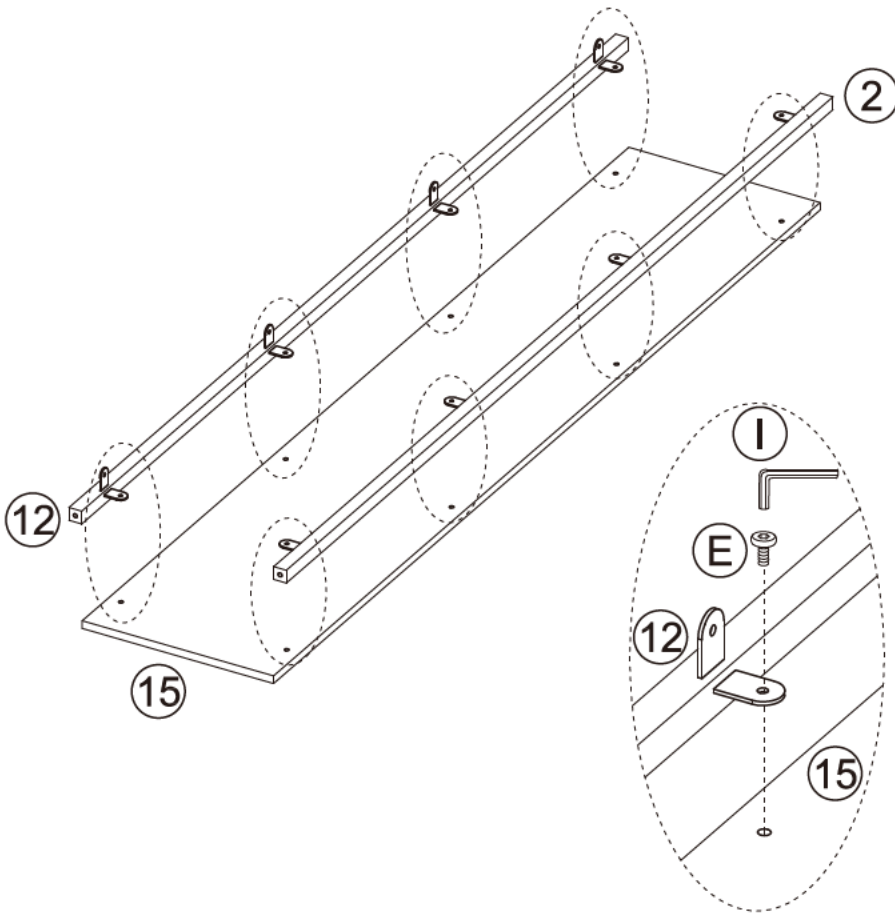
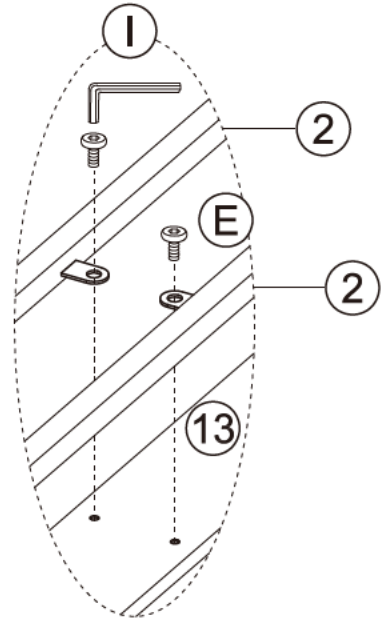
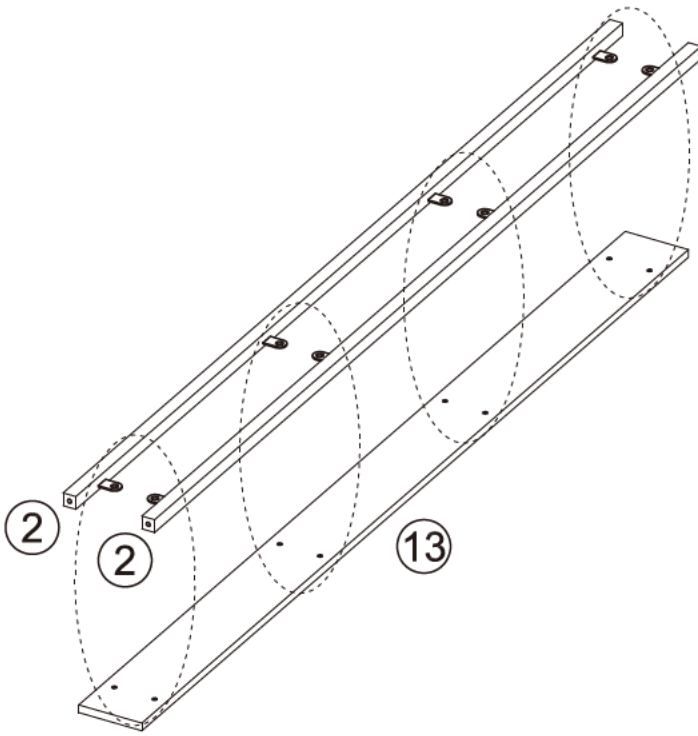
1



	<b>E X16</b>
	<b>I X1</b>

2

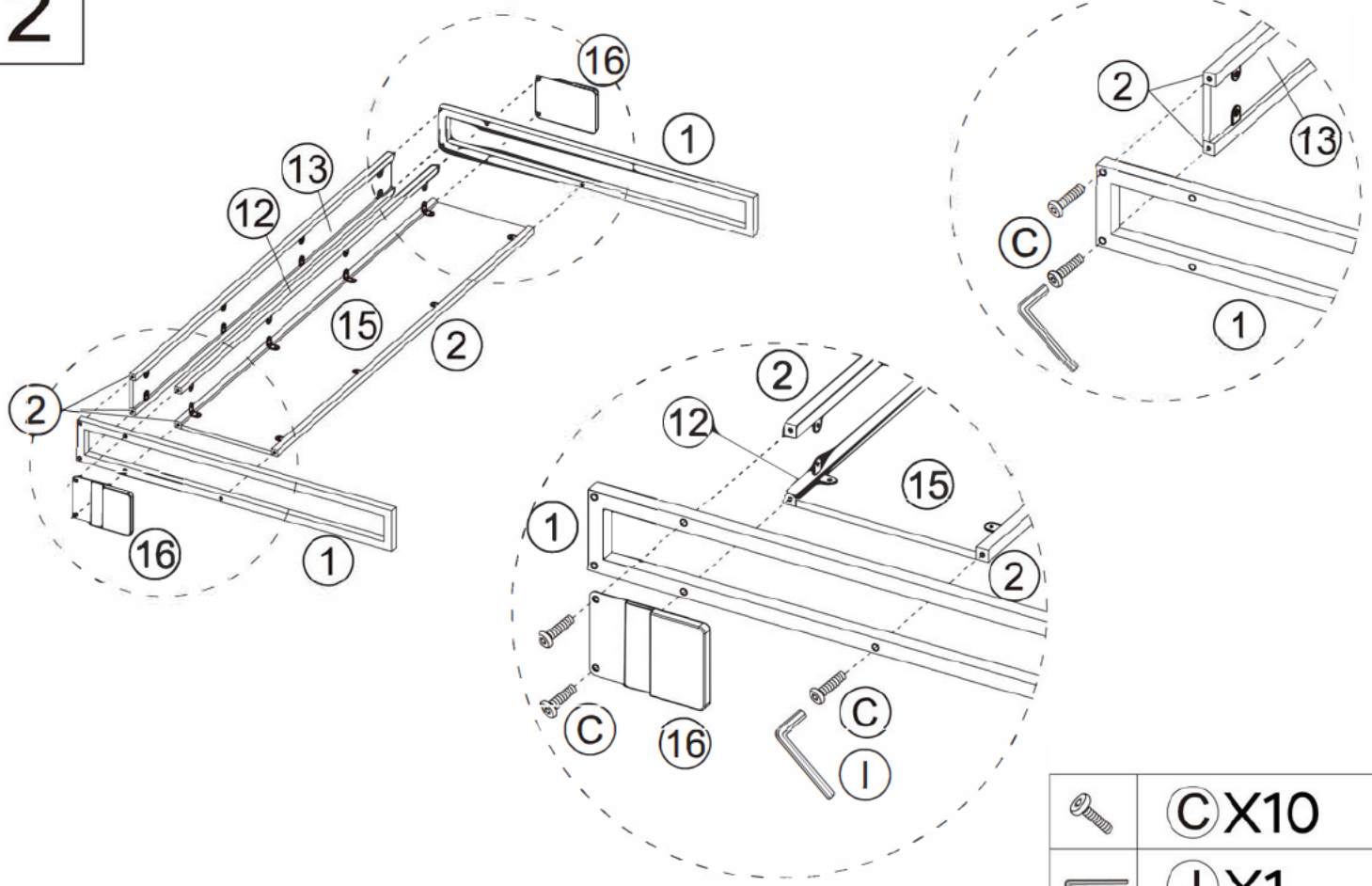

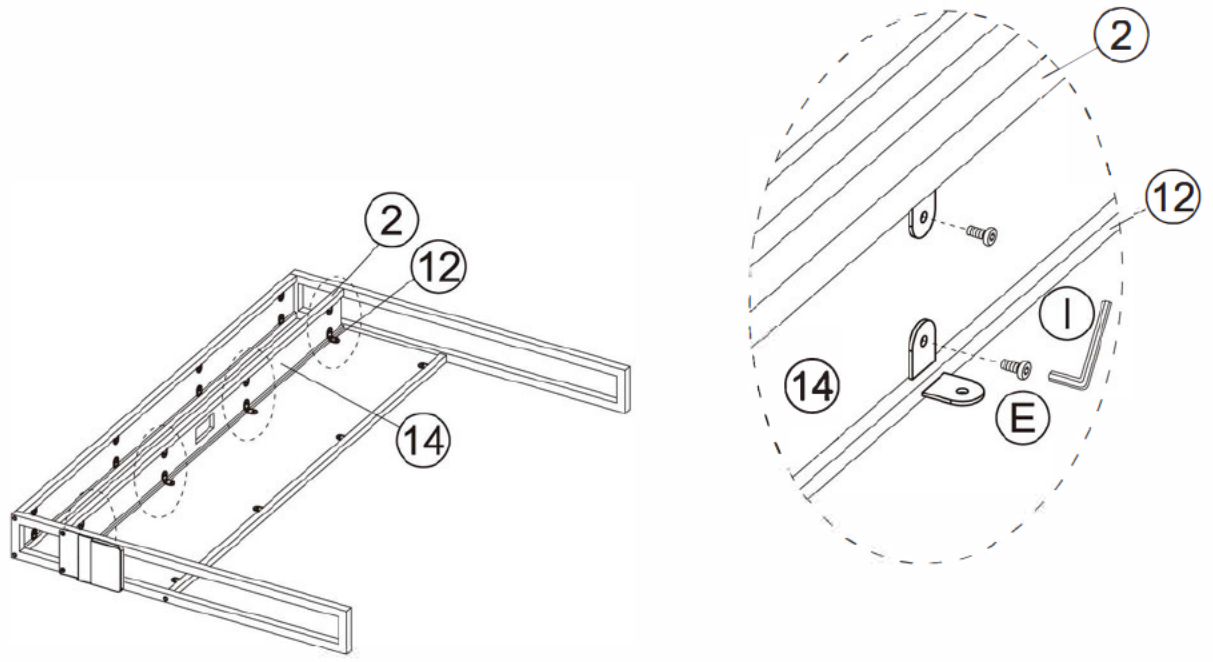

3



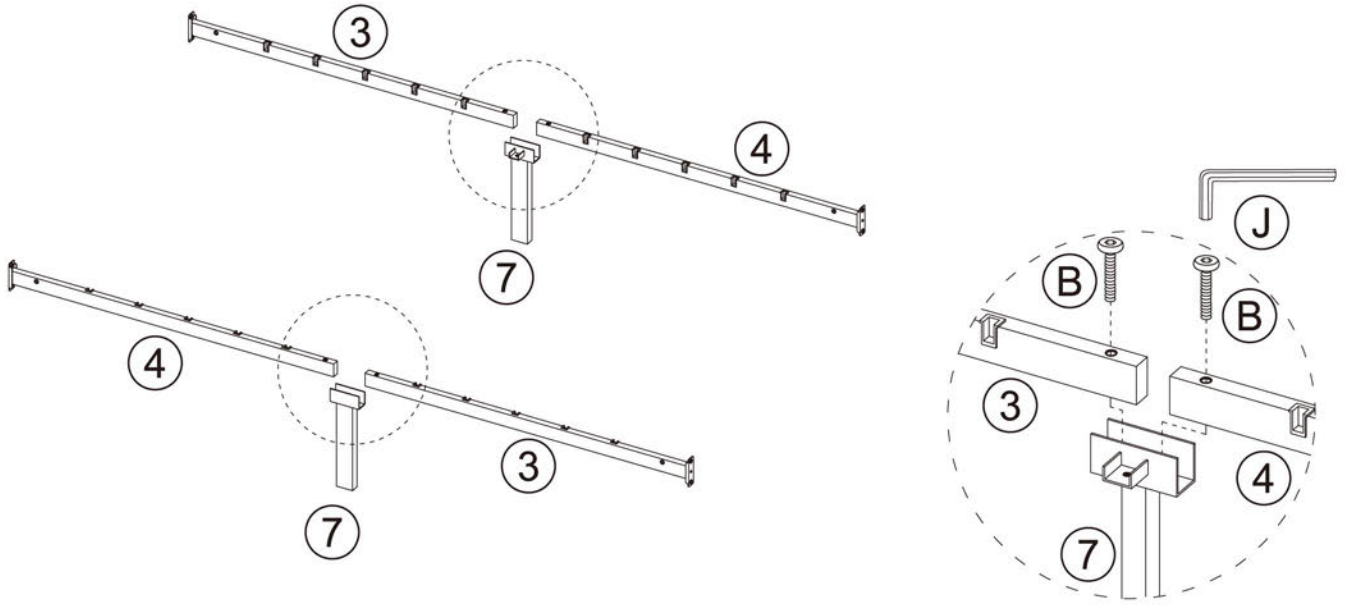

4



	<b>B X4</b>
	<b>J X1</b>

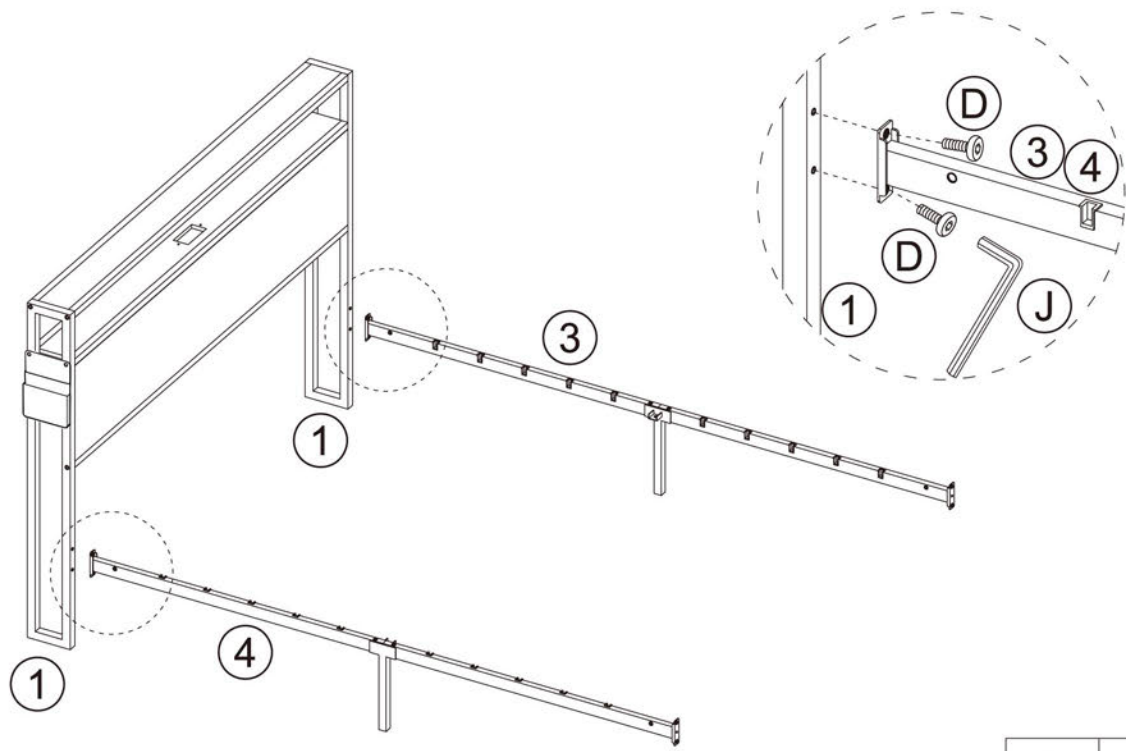

5



	<b>D X4</b>
	<b>J X1</b>

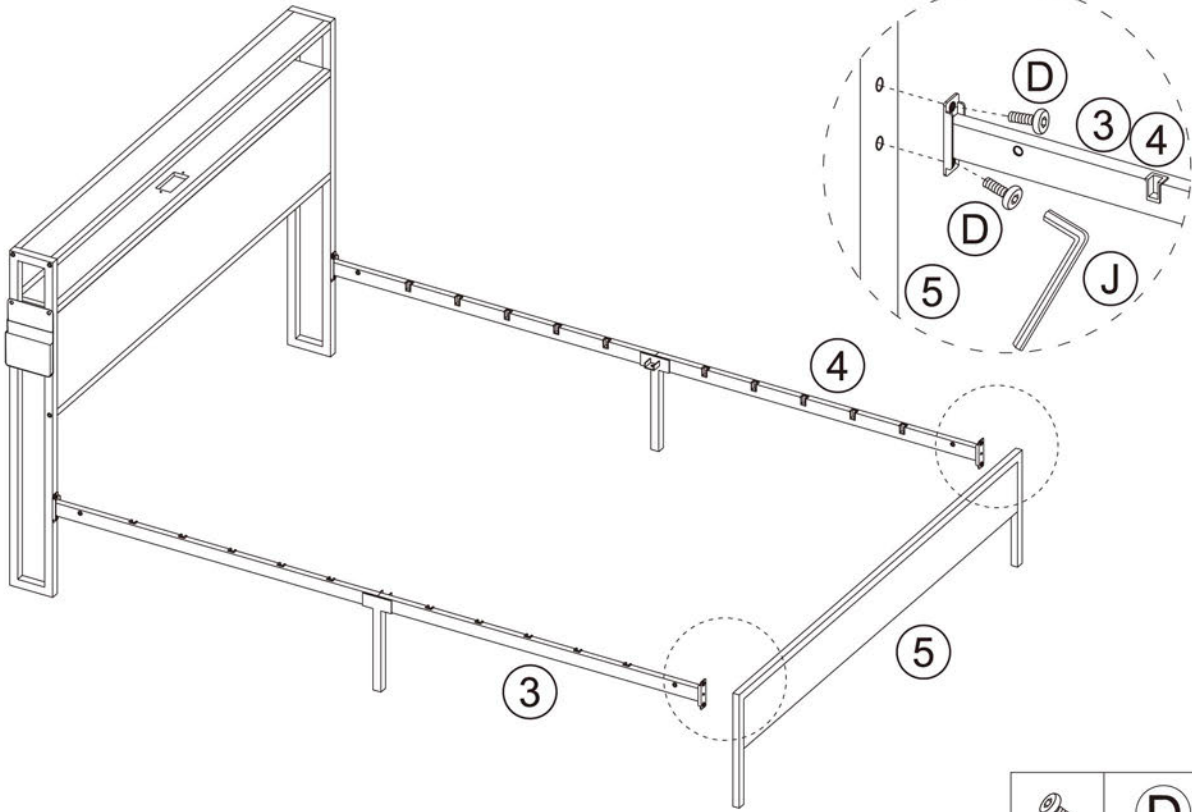

6



	<b>D</b> X4
	<b>J</b> X1

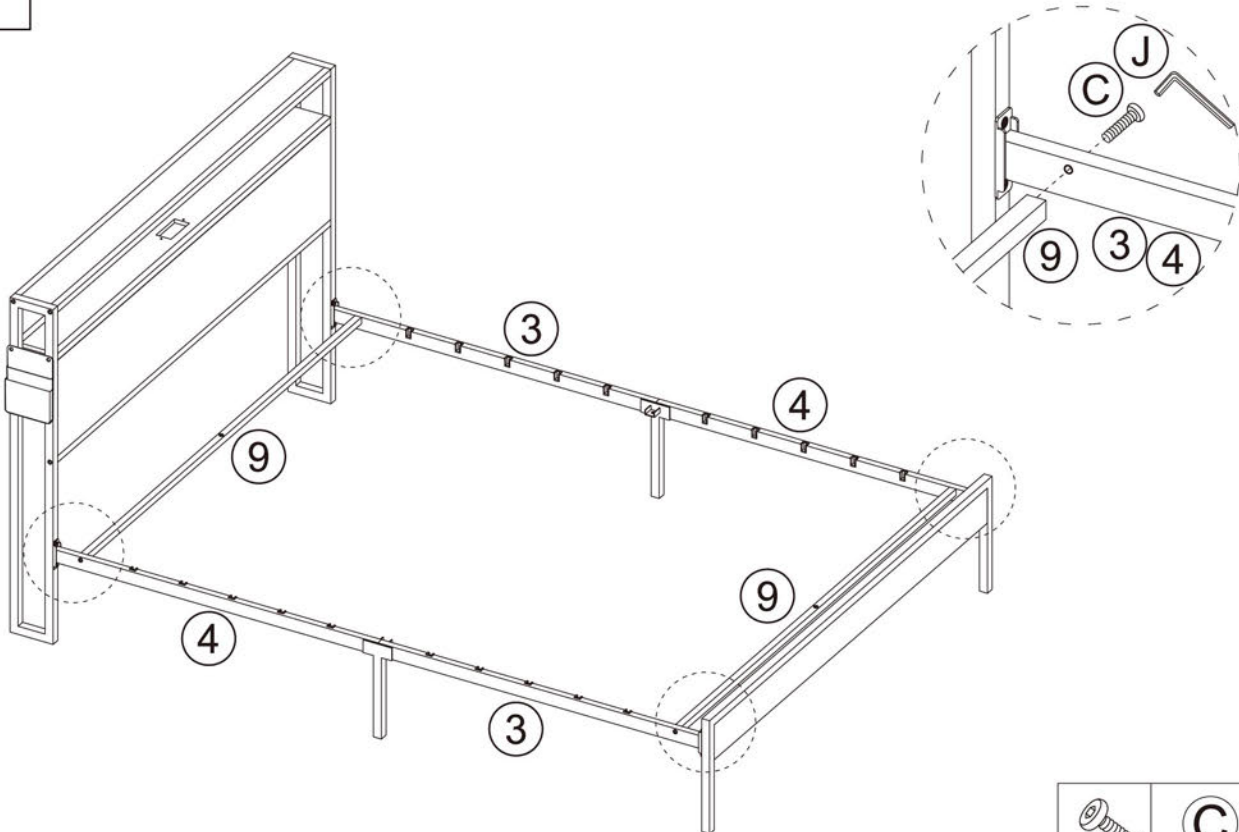

7



	<b>C</b> X4
	<b>J</b> X1

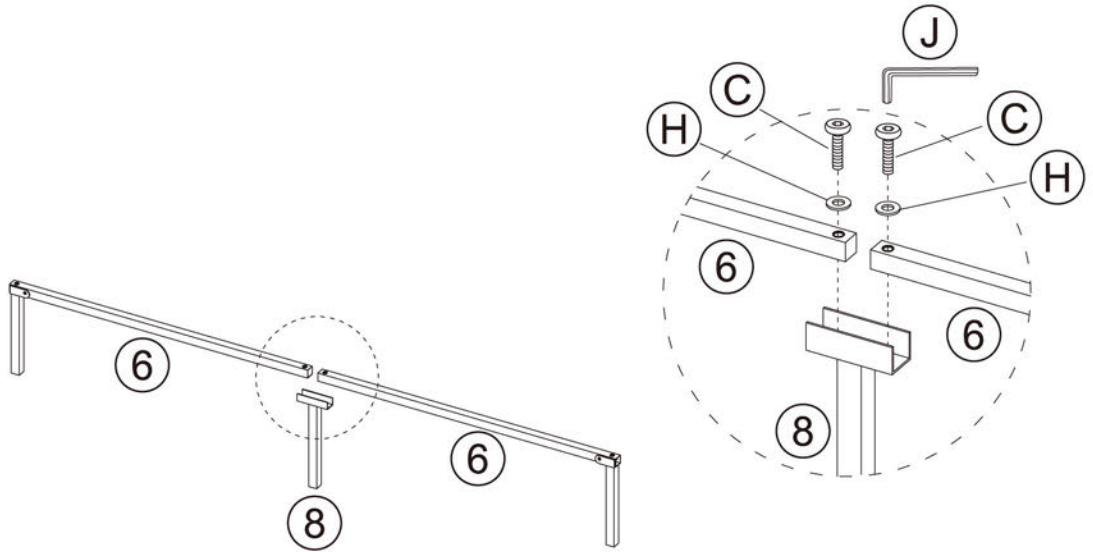

8



	C X2
	H X2
	J X1

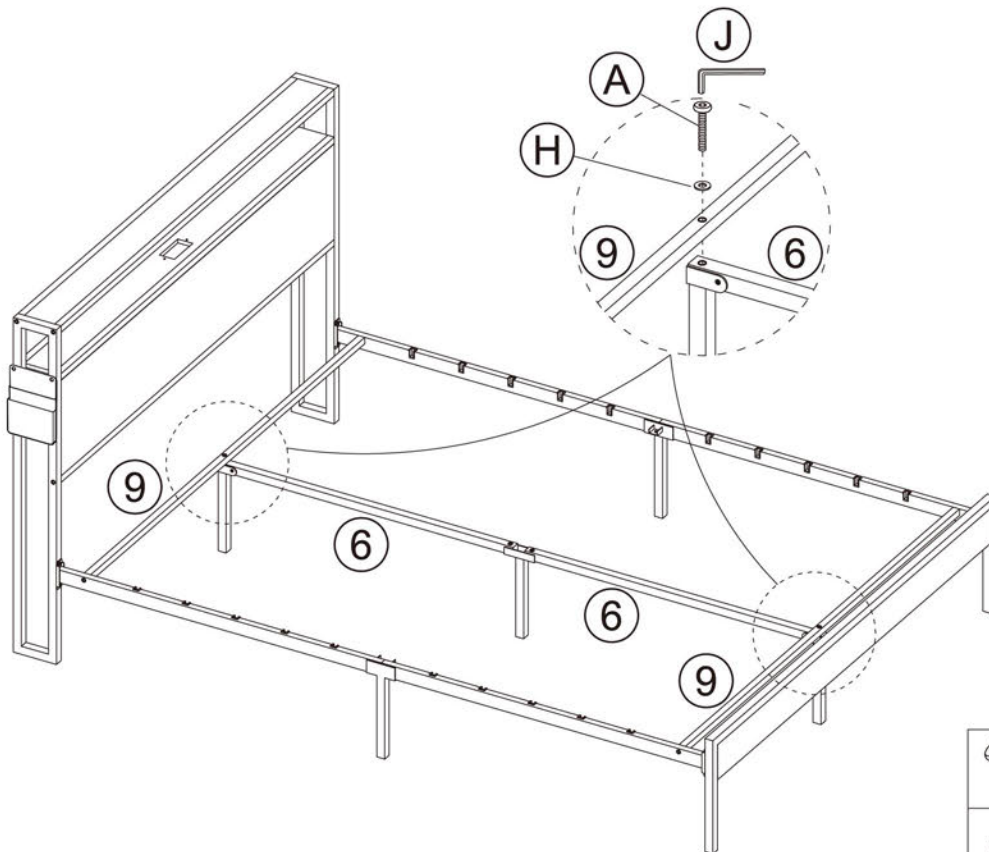



9

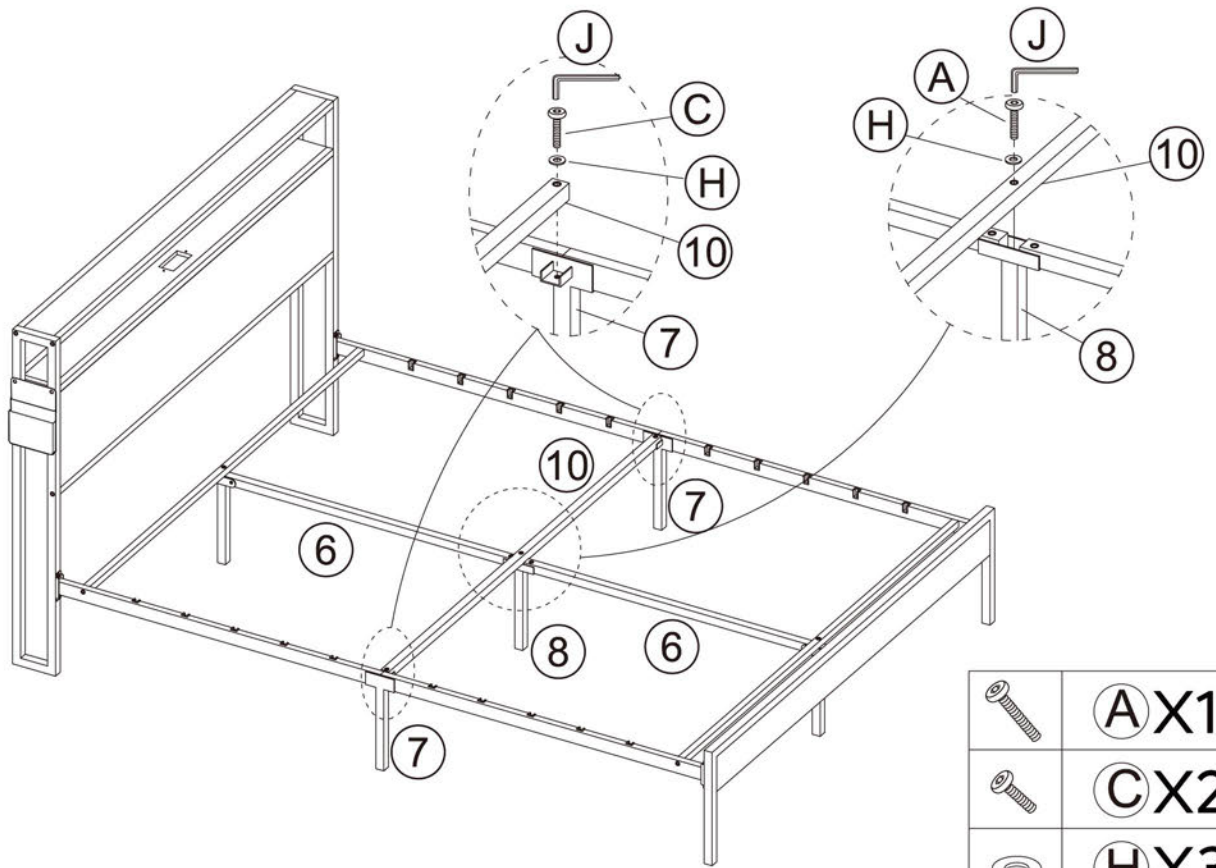

	A X2
	H X2
	J X1

10



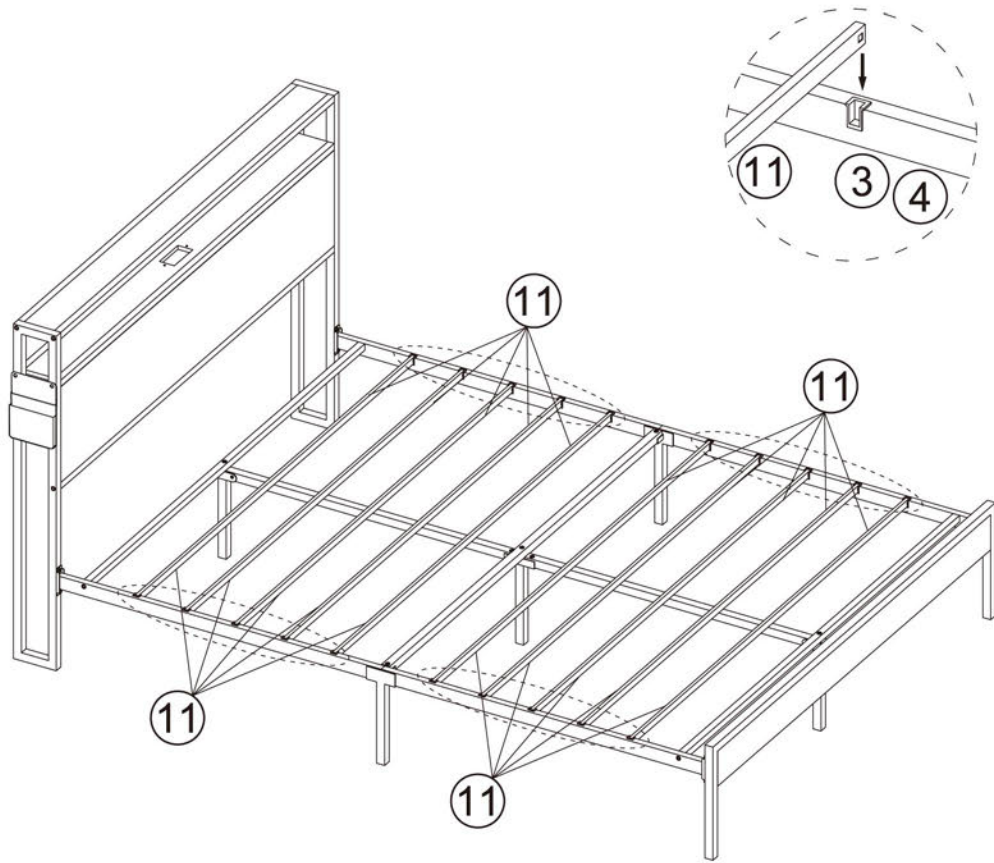

	A X1
	C X2
	H X3
	J X1

11

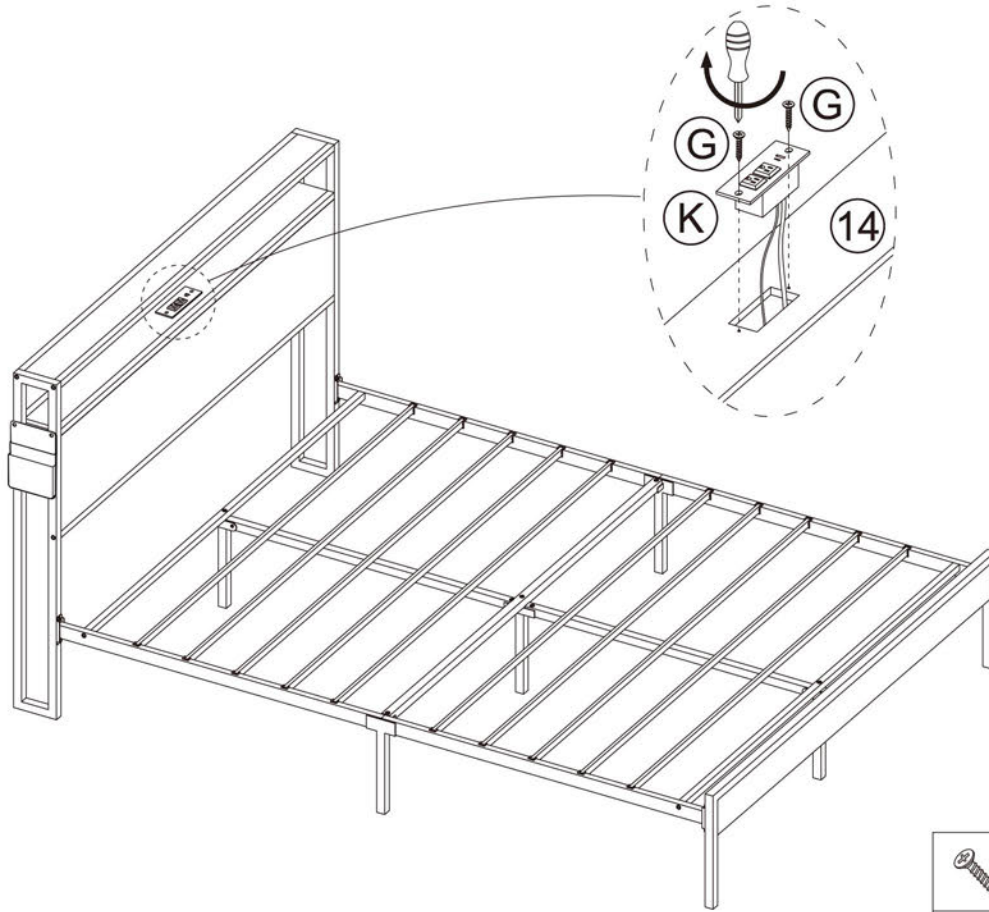

12



	G X2
	K X1

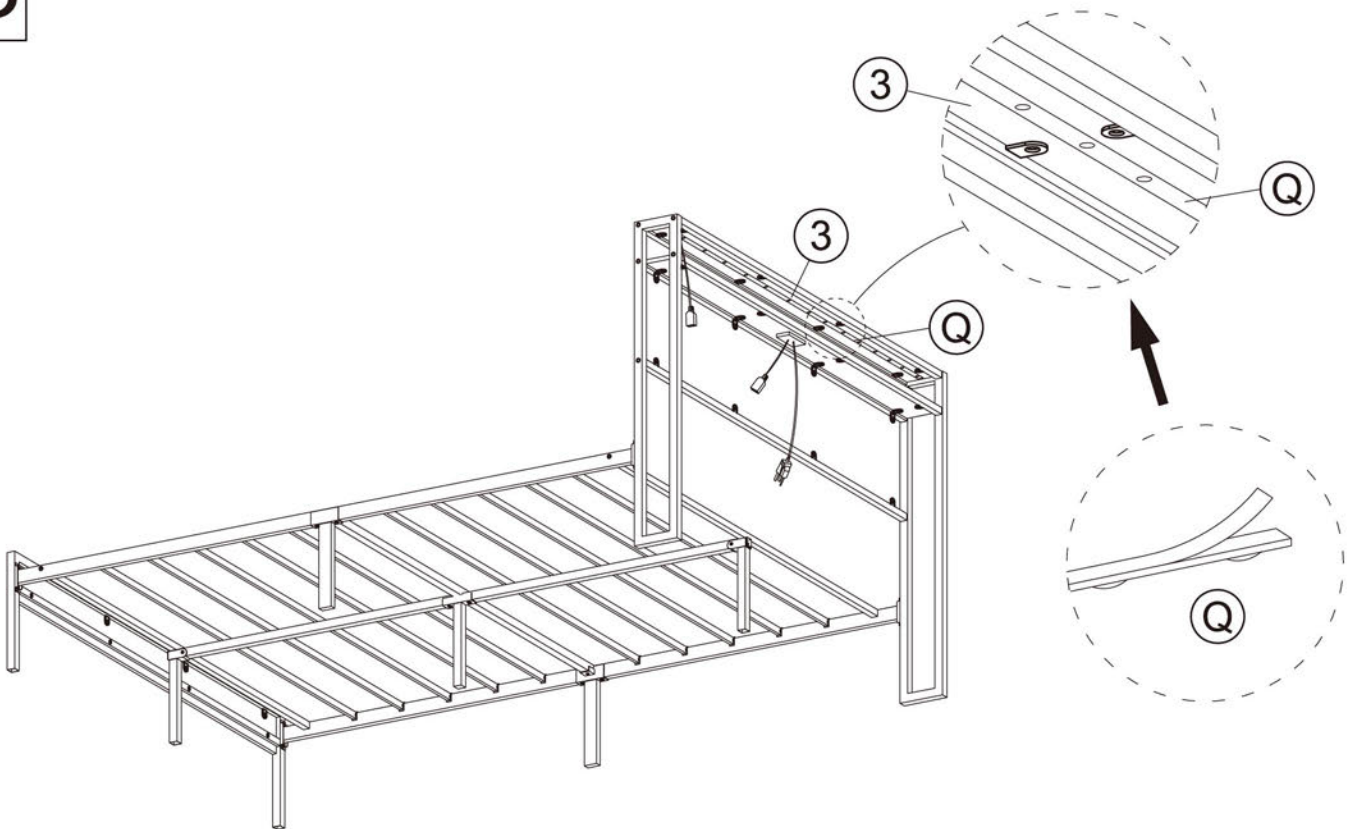

13



	Q X1
---	------

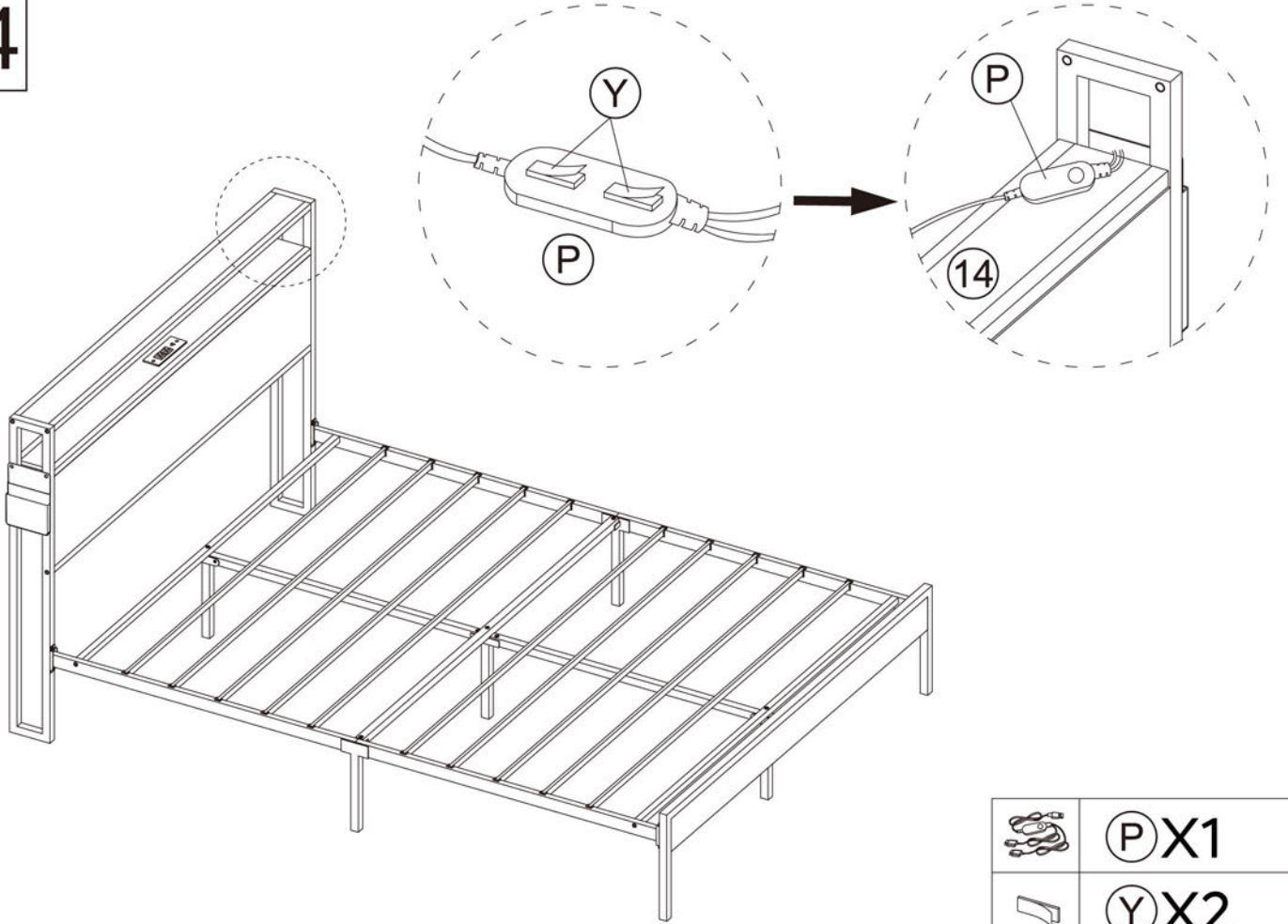

14

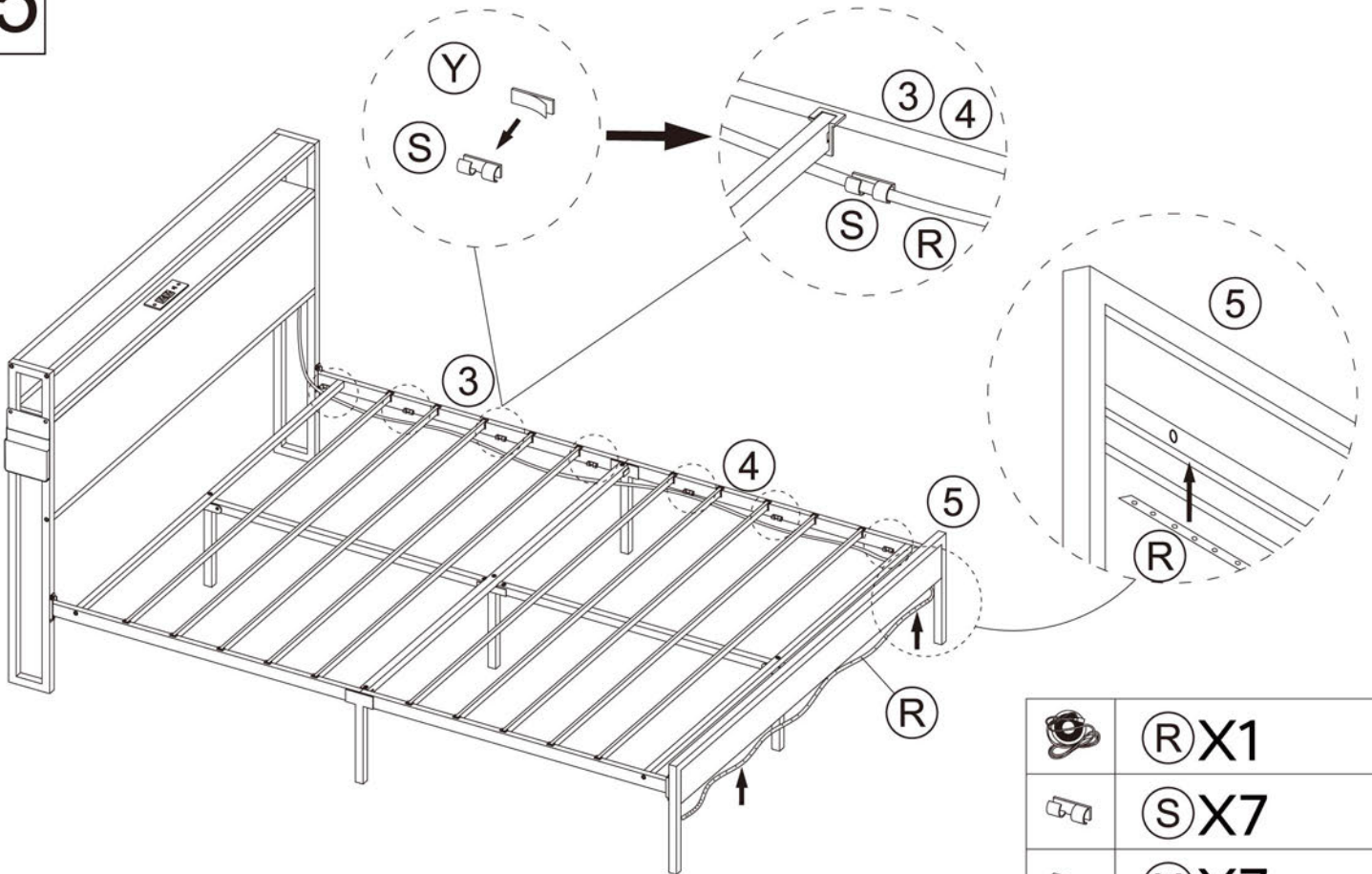

	(P) X1
	(Y) X2

15



	(R) X1
	(S) X7
	(Y) X7

# 16

Watch the direction

Attention au sens  
Achten Sie auf die Richtung  
Prestare attenzione alle indicazioni

Mirar la dirección  
方向に注意してください  
注意方向

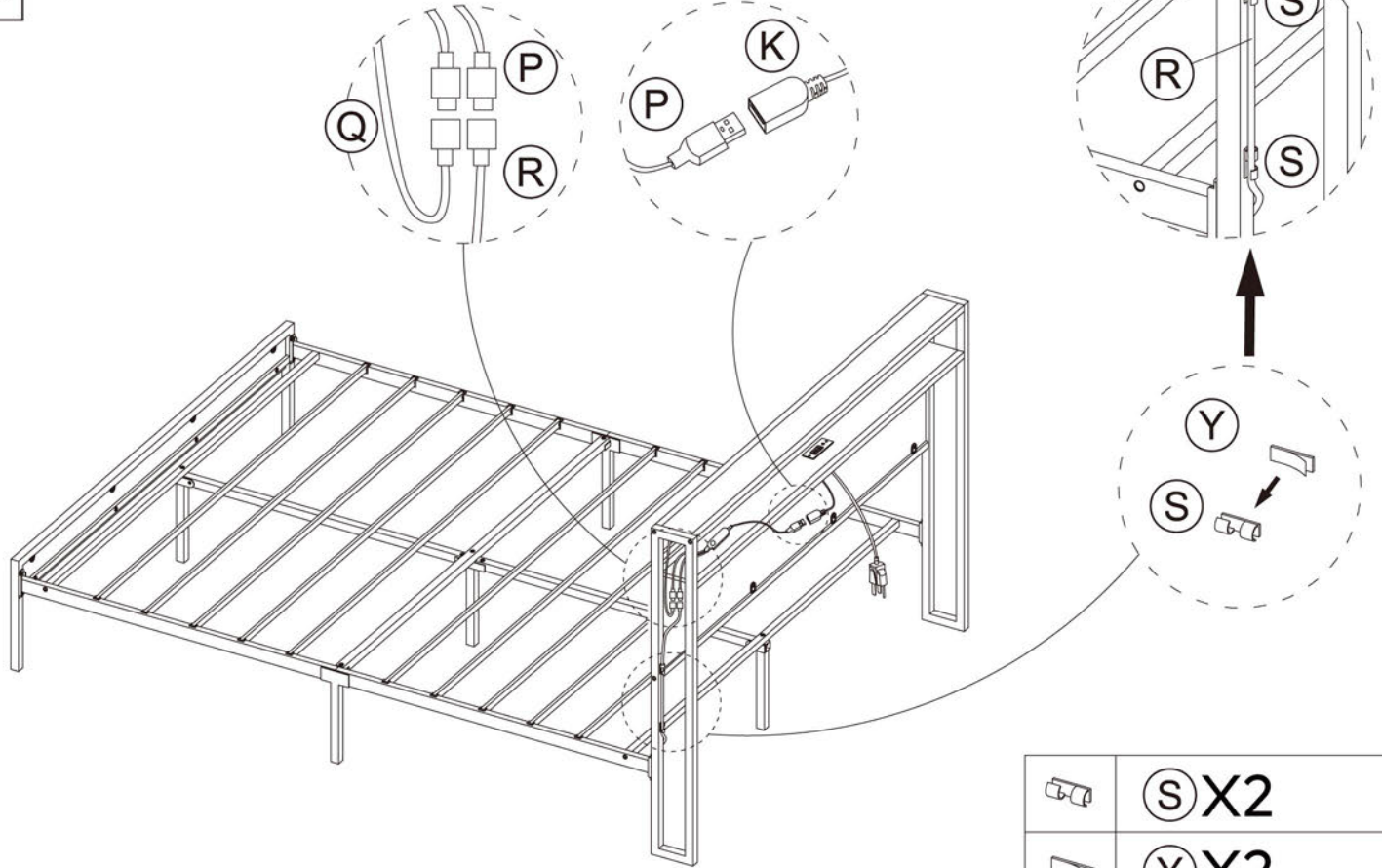

# 17

