

STORAGE BED FULL/QUEEN ASSEMBLY INSTRUCTIONS

BOX#1

A. HEADBOARD

1 PC

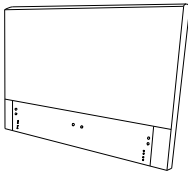

HARDWARE KIT PACKED IN BOX #1

1	ALLEN BOLT(1/4"x1")		8 PCS
2	FLAT WASHER(5/16")		8 PCS
3	LOCK WASHER(5/16")		8 PCS
4	ALLEN KEY(1/4")		1 PC

BOX#2

- B. LEFT SIDE RAIL 1 PC
- C. RIGHT SIDE RAIL 1 PC
- D. FOOTBOARD 1 PC
- E. SLAT 26 PCS
- F. CENTER SLAT SUPPORT 1 PC
- G. SIDE RAIL SLAT CLIP 26 PCS
- H. CENTER SUPPORT SLAT CLIP 13 PCS
- I. SLAT SUPPORT LEG 2 PCS
- J. METAL SUPPORT LEG 1 PC
- K. METAL SUPPORT BRACE 1 PC

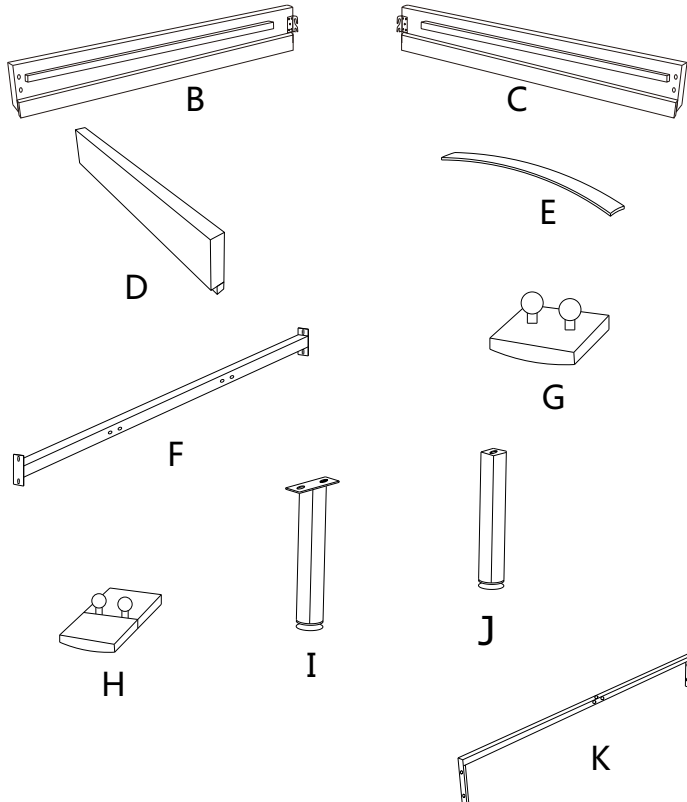

HARDWARE KIT PACKED IN BOX #2

1	ALLEN BOLT(5/16"x1")		6 PCS
2	ALLEN BOLT(5/16"x2-1/2")		7 PCS
3	FLAT WASHER(5/16")		19 PCS
4	LOCK WASHER(5/16")		13 PCS
5	WRENCH(5/16")		1 PC
6	ALLEN KEY(5/16")		1 PC
7	HEX NUT(5/16"x12)		6 PCS

HARDWARE KIT PACKED IN BOX #3

1	ALLEN BOLT(1/4"x1-1/4")		8 PCS
2	ALLEN BOLT(1/4"x5/8")		12 PCS
3	FLAT WASHER(1/4")		8 PCS
4	LOCK WASHER(1/4")		8 PCS
5	ALLEN KEY(1/4")		1 PC

BOX#3

L. DRAWER BOX
M. CASTERS

2 PCS
6 PCS

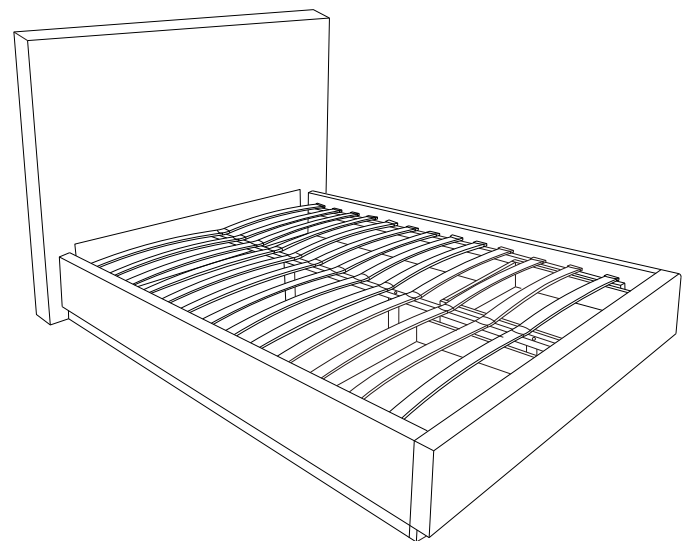
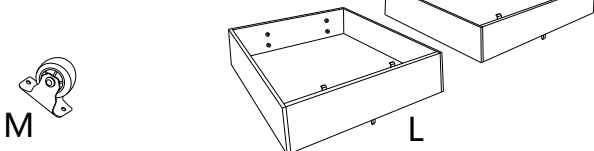

STORAGE BED FULL/QUEEN ASSEMBLY INSTRUCTIONS

STEP 1:

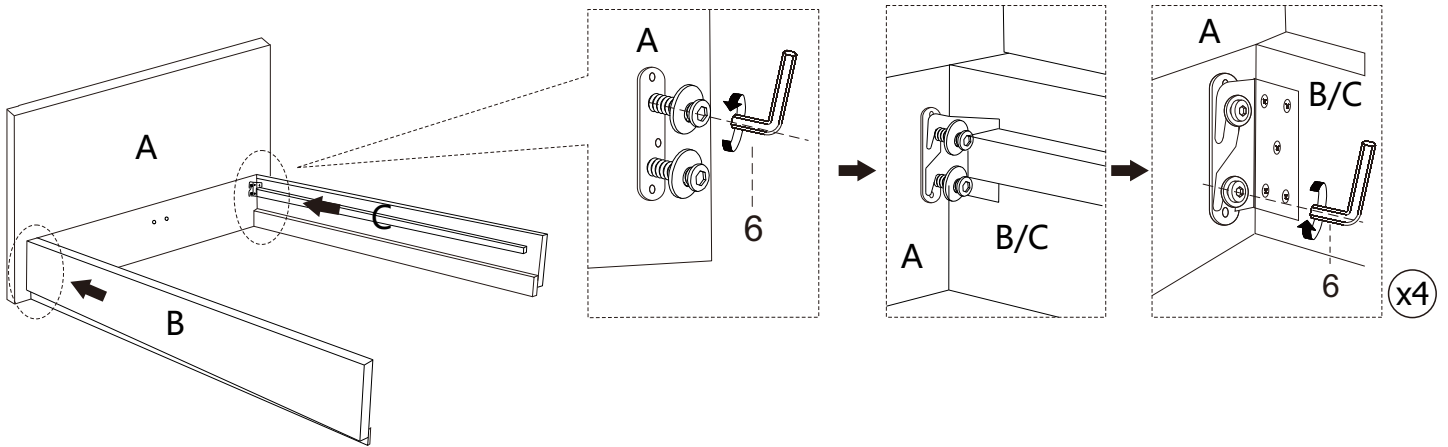

STEP 2:

NOTE: USE HARDWARE PACKED IN BOX #2 FOR STEPS 2-5.

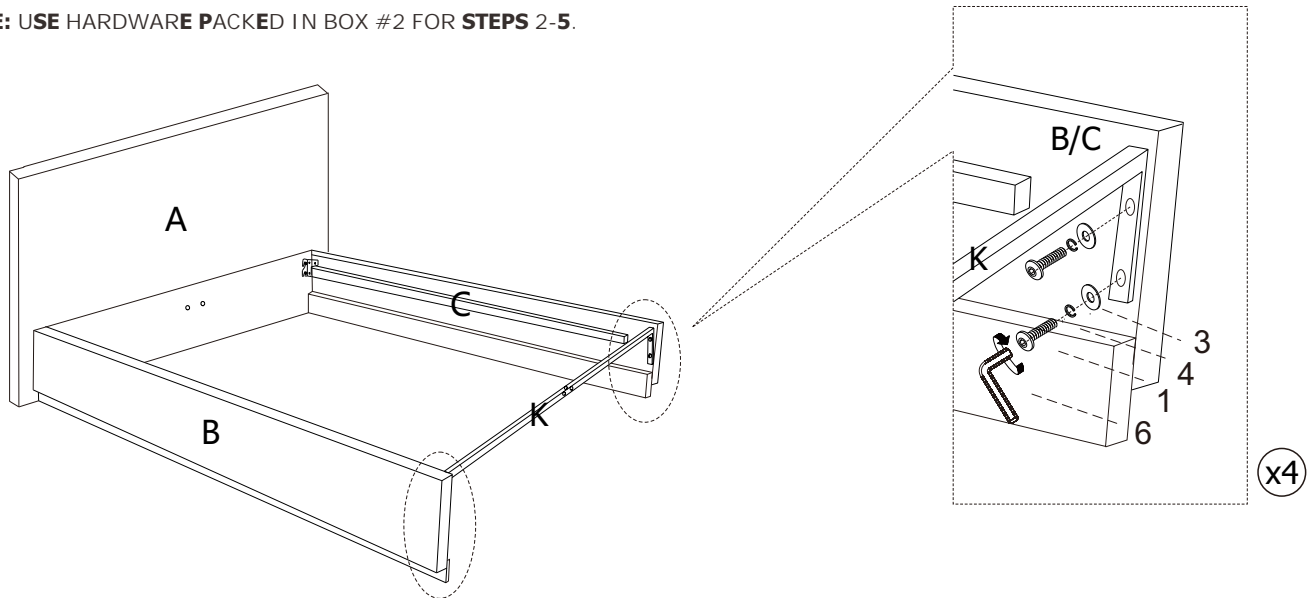

STEP 3:

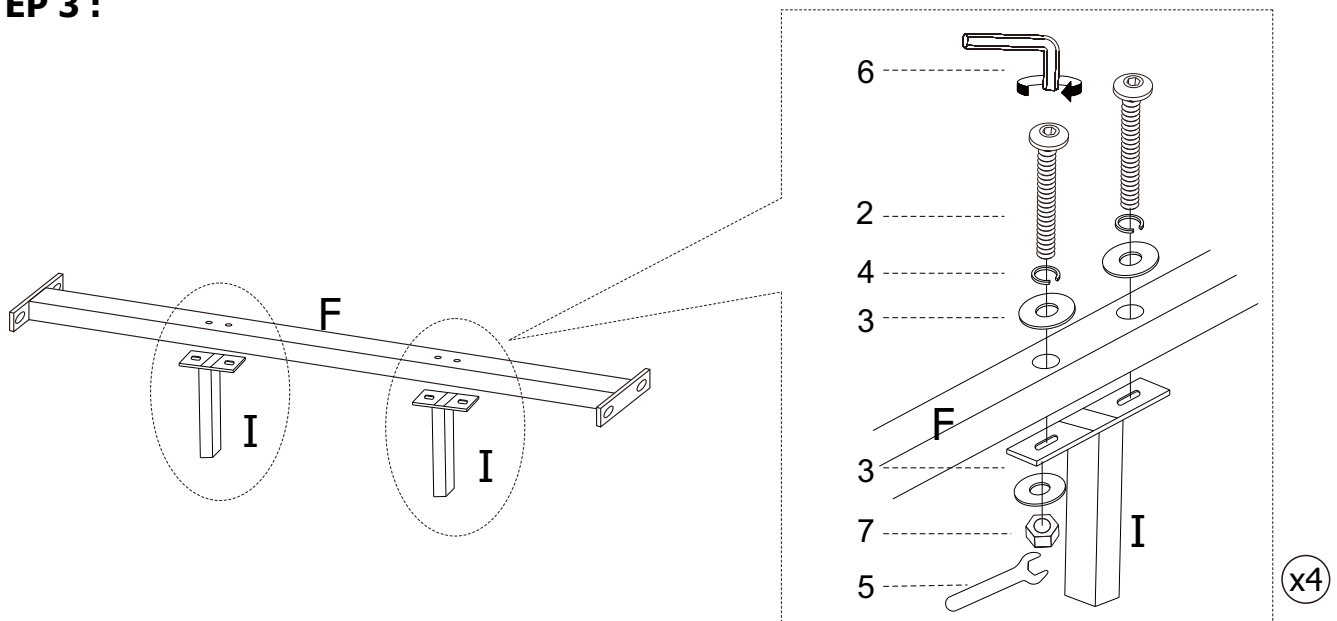

STORAGE BED FULL/QUEEN

ASSEMBLY INSTRUCTIONS

STEP 4:

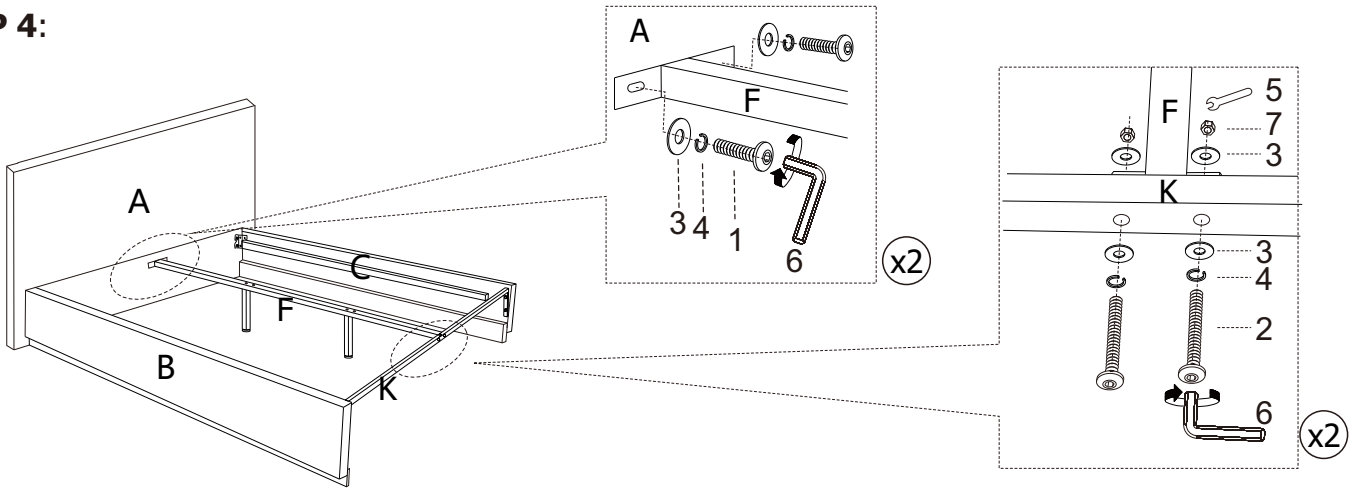

STEP 5:

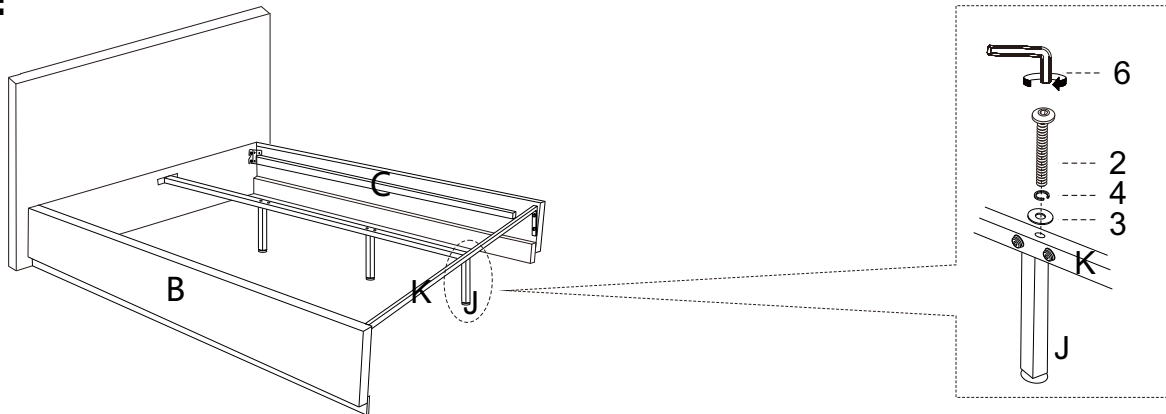

STEP 6:

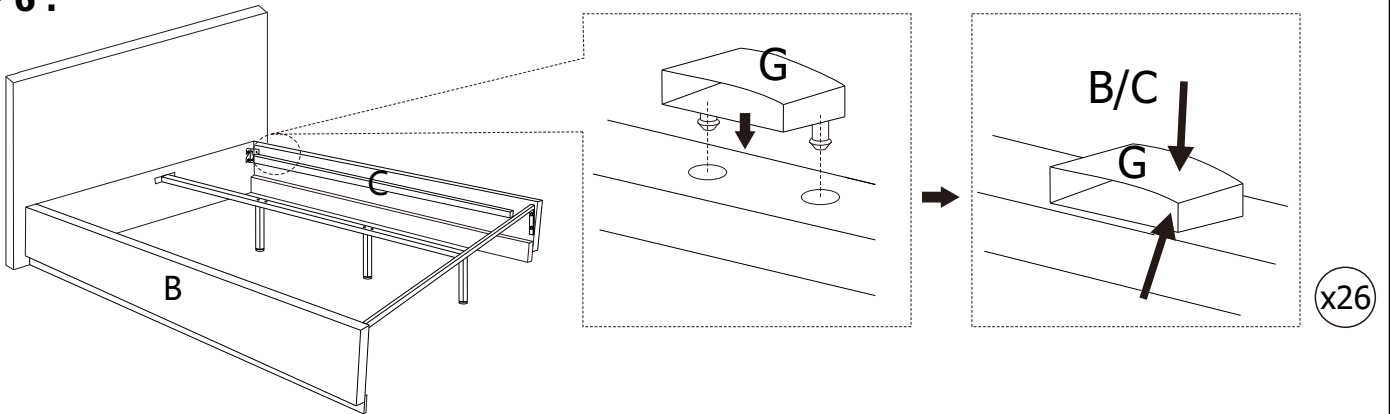

STEP 7:

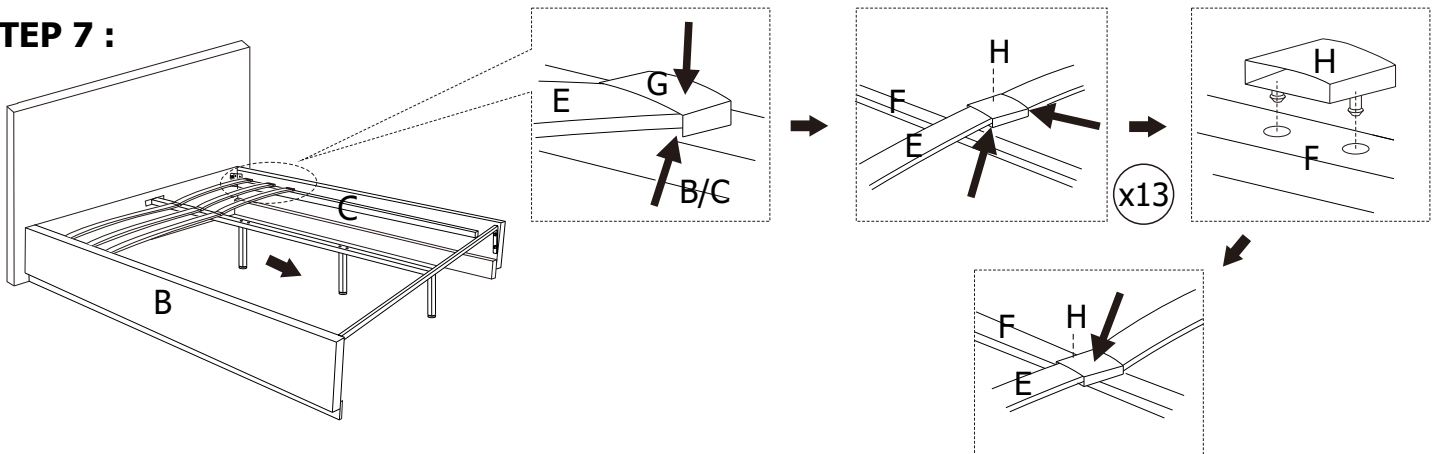

STORAGE BED FULL/QUEEN

ASSEMBLY INSTRUCTIONS

STEP 8 :

NOTE: USE HARDWARE PACKED IN BOX #3 FOR STEPS 8 & 9.

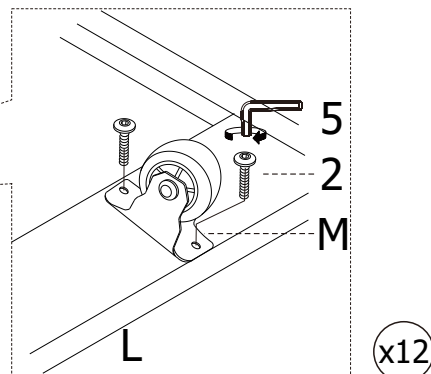
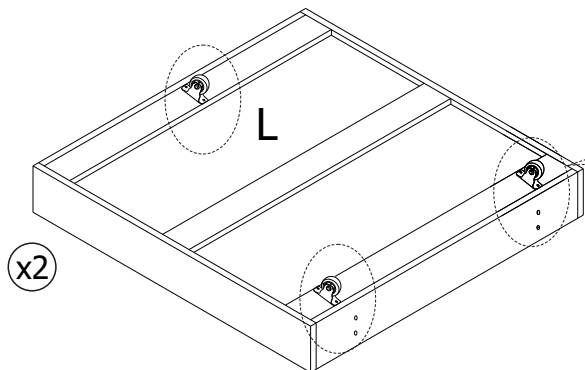

STEP 9 : DRAWER BOXES ARE NOT SIDE SPECIFIC AND CAN BE ATTACHED TO EITHER LEFT OR RIGHT SIDE OF FOOTBOARD.

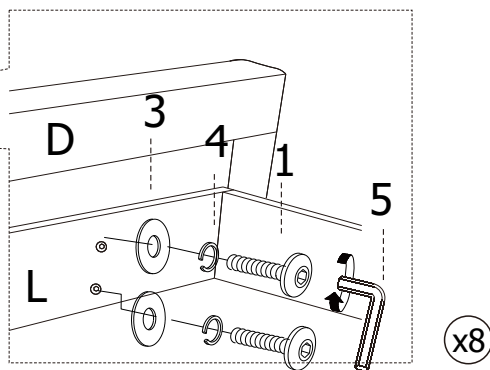
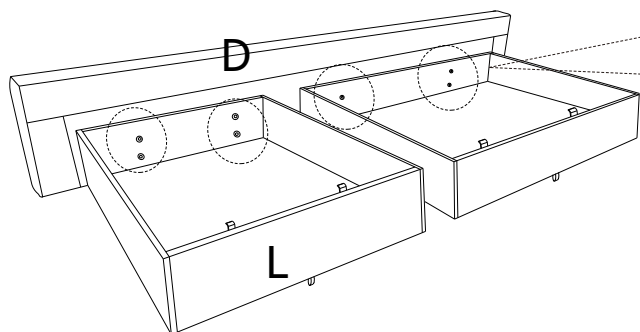

STEP 10 :

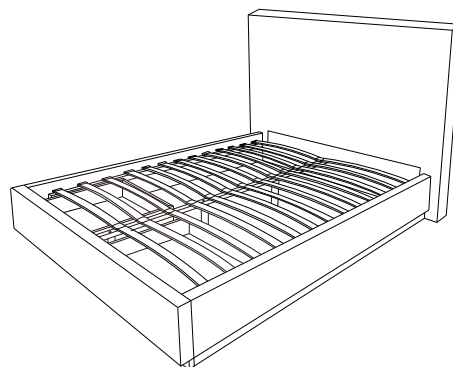
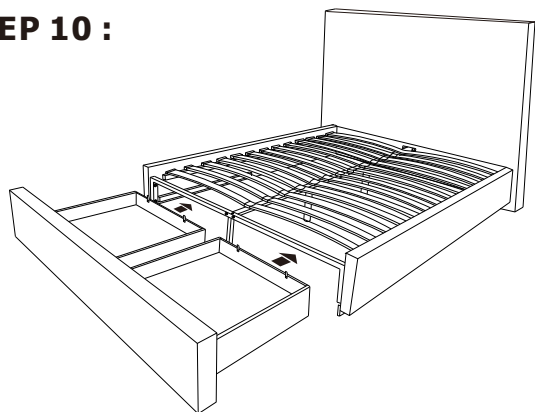

ASSEMBLY COMPLETE

INSTRUCTIONS FOR ADJUSTING LEVELERS :

POSITION THE BED IN YOUR ROOM. LOCATE LEVELERS UNDER EACH SUPPORT LEG (I/J).

TURN COUNTER-CLOCKWISE TO EXTEND, CLOCKWISE TO RETRACT.

ADJUST LEVELERS UNTIL EACH LEG SUPPORT IS APPLYING EQUAL UPWARD PRESSURE ON THE CENTER SLAT.

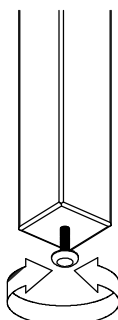

MAINTENANCE INSTRUCTIONS:

- PERIODICALLY CHECK ALL FITTINGS AND TIGHTEN IF NECESSARY, AS THEY CAN LOOSEN OVER TIME.
- ALWAYS REMOVE BOX SPRING AND MATTRESS BEFORE MOVING THE BED.
- LIFT THE BED WHEN MOVING IT. DRAGGING THE BED CAN DAMAGE THE CENTER SUPPORT.
- READJUST LEVELERS AFTER MOVING THE BED.