

User Manual

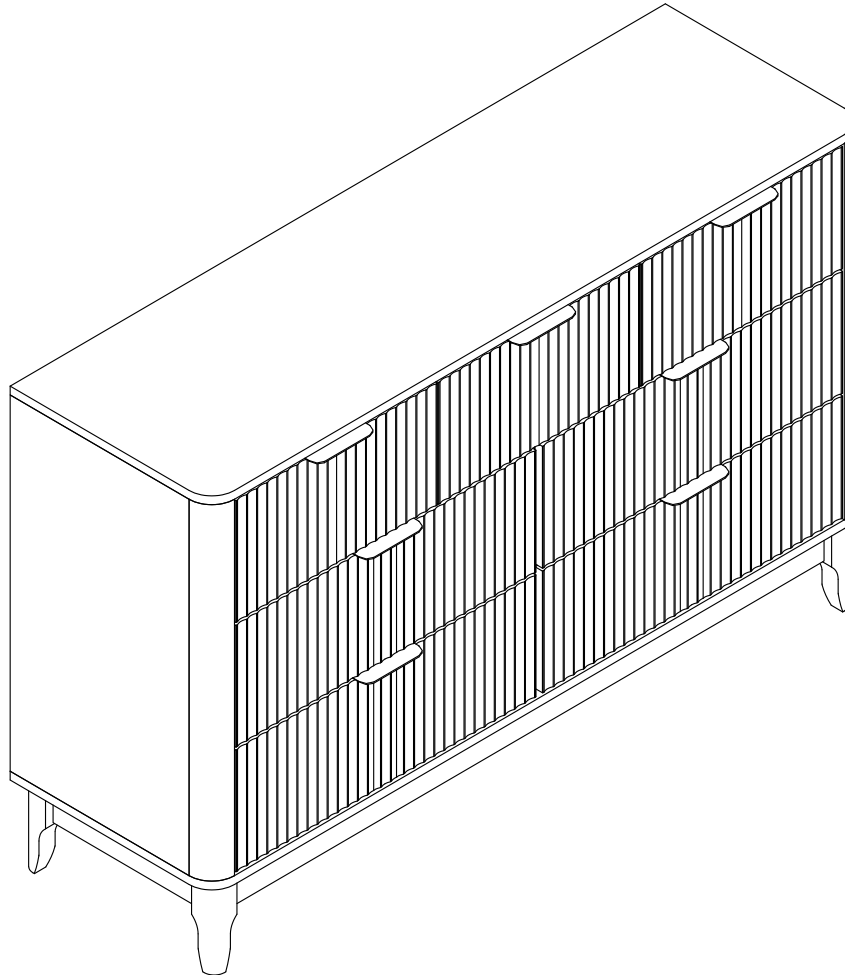

It is recommended to use the text guidance in combination with the assembly video and then start assembling.
If you cannot find the video guidance,

please contact customer service

Tel: +1 7402568754

E-mail: service_april@163.com



Tool Required Not Provided

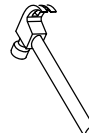
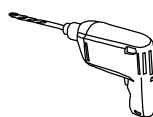
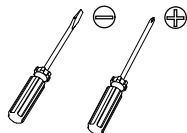

Assembling Instruction

All accessories and installation tools are included

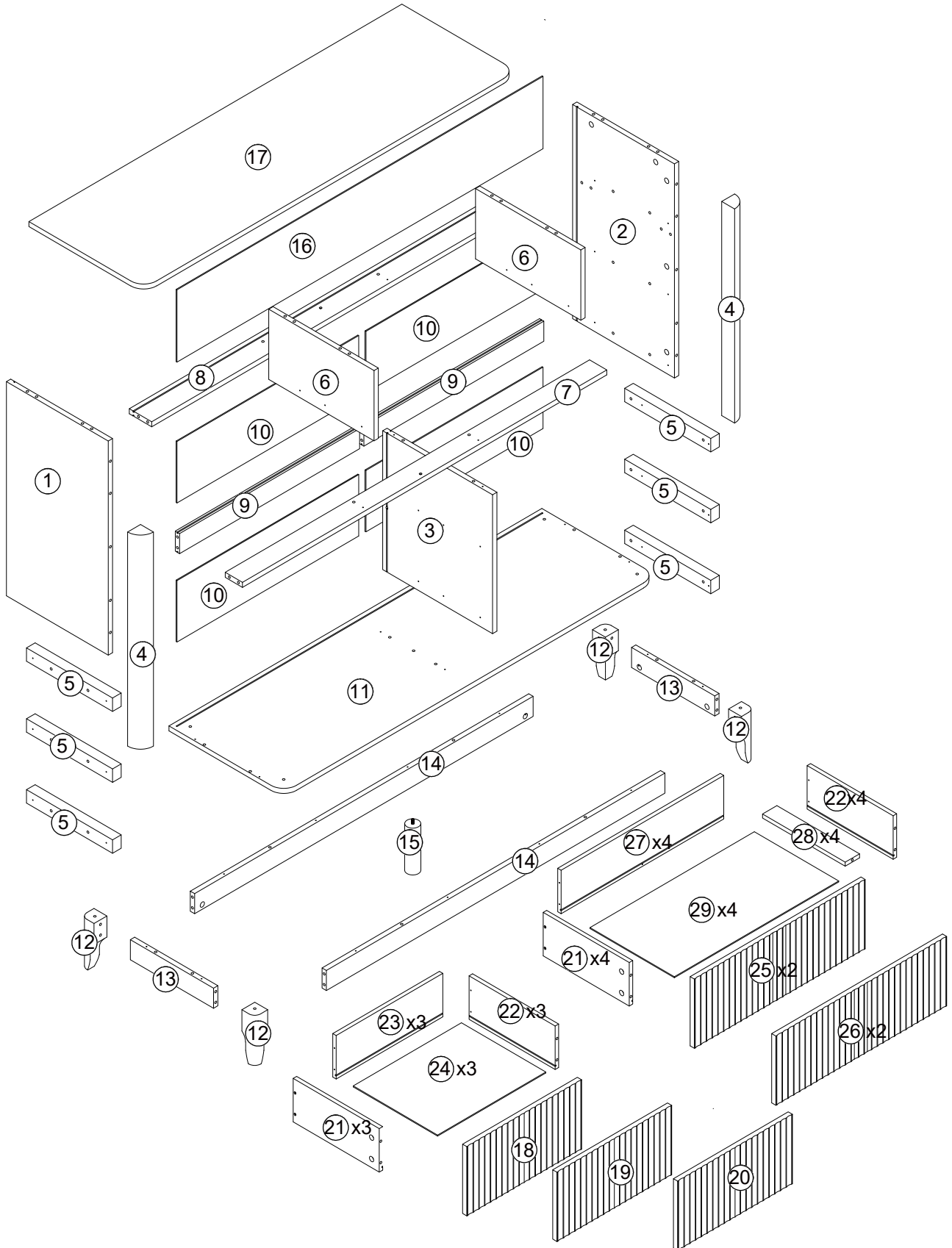

A	x66(+2)	B	x66(+2)	C	x56(+2)	D	x40(+2)	E	x84(+2)	F	x12
Ø6x35mm		Ø15x10mm		Ø6x30mm		Ø4x35mm		Ø3.5x12mm		Ø4x35mm	
G	x2	H	x2	I	x20	J	x7	K	x12	L	x1
Ø4x14mm		Ø4x14mm		Ø3x16mm		Ø3x12mm		Ø4x50mm		Ø4x50mm	
M	x6	N	x4	O	x1	CL	x7	CR	x7	DL	x7
Ø4x40mm		Ø7x40mm		L300mm		L300mm		L300mm		L300mm	
DR	x7										
L300mm											

Please check your package.

Feel free to contact us if parts are missing or damaged: service_April@163.com

Our staff will solve the problem for you at the first time.^^

1

X 2

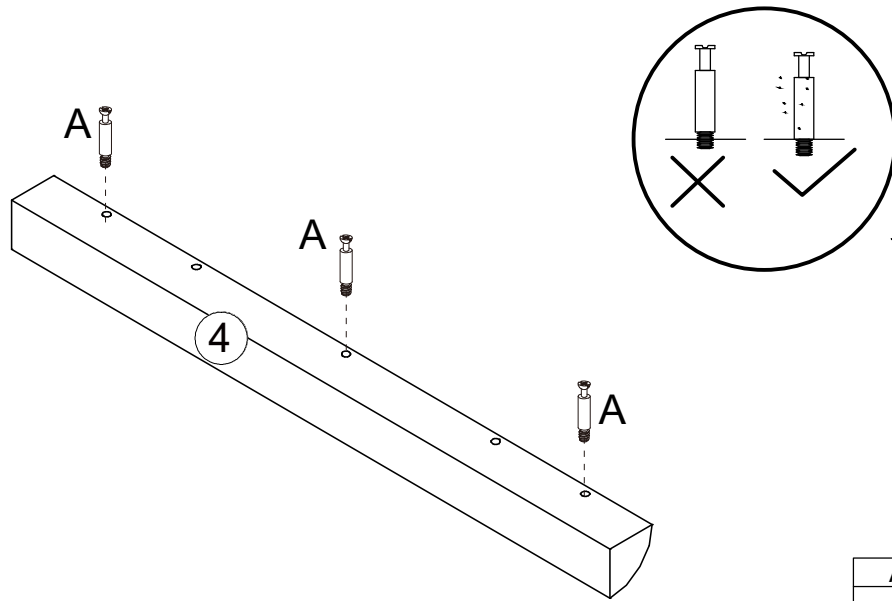

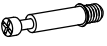

A	x6
	

Screw bolt A (3 pcs) into the corresponding positions on board #4, and repeat the operation once.

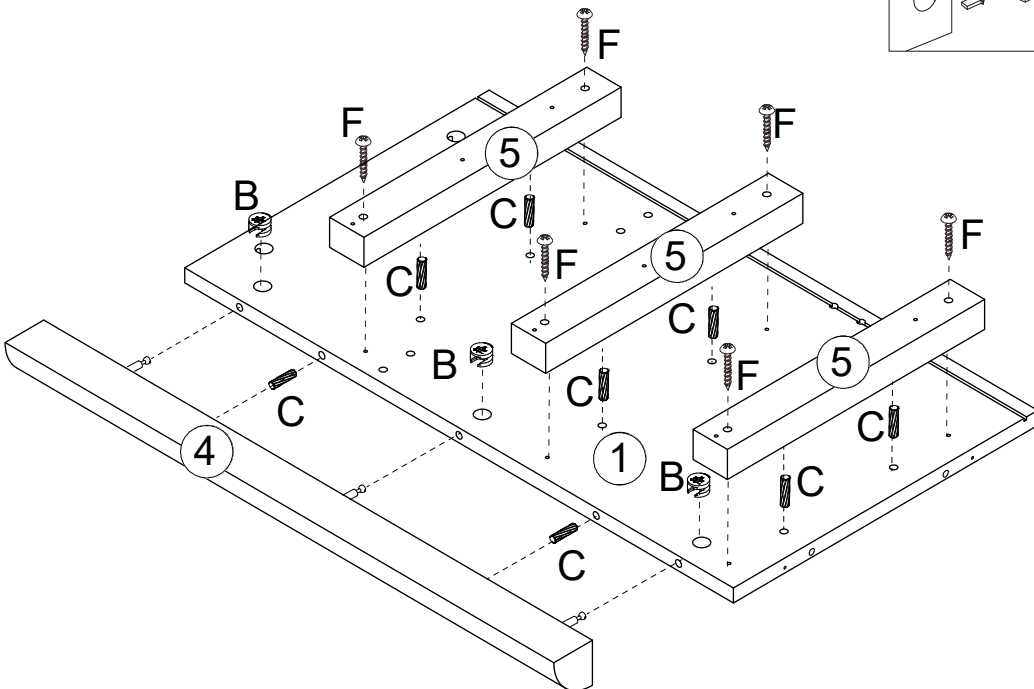
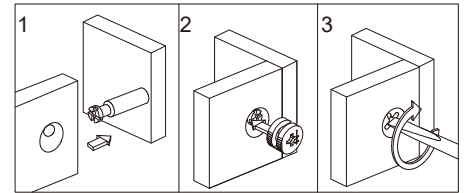
2



F	x6
	

C	x8
	

B	x3
	

2.1 Take one of the boards #4 in the previous step, connect and fix them to the side of board #1 with cork C (2 pcs) according to the position shown in the diagram, insert bolt B (3 pcs) into the corresponding position of board #1 (the arrow on the surface of bolt B should be aligned with the opening on the side of the hole), rotate and tighten lock B (3 pcs) to fix board #4 and board #1.

2.2 Use cork C (2 pcs) to connect board #5 to board #1, and then use screw F (2 pcs) to fix board #5 to board #1. Repeat this operation until boards #5 (3 pcs) are fixed at the corresponding positions of board #1.

3

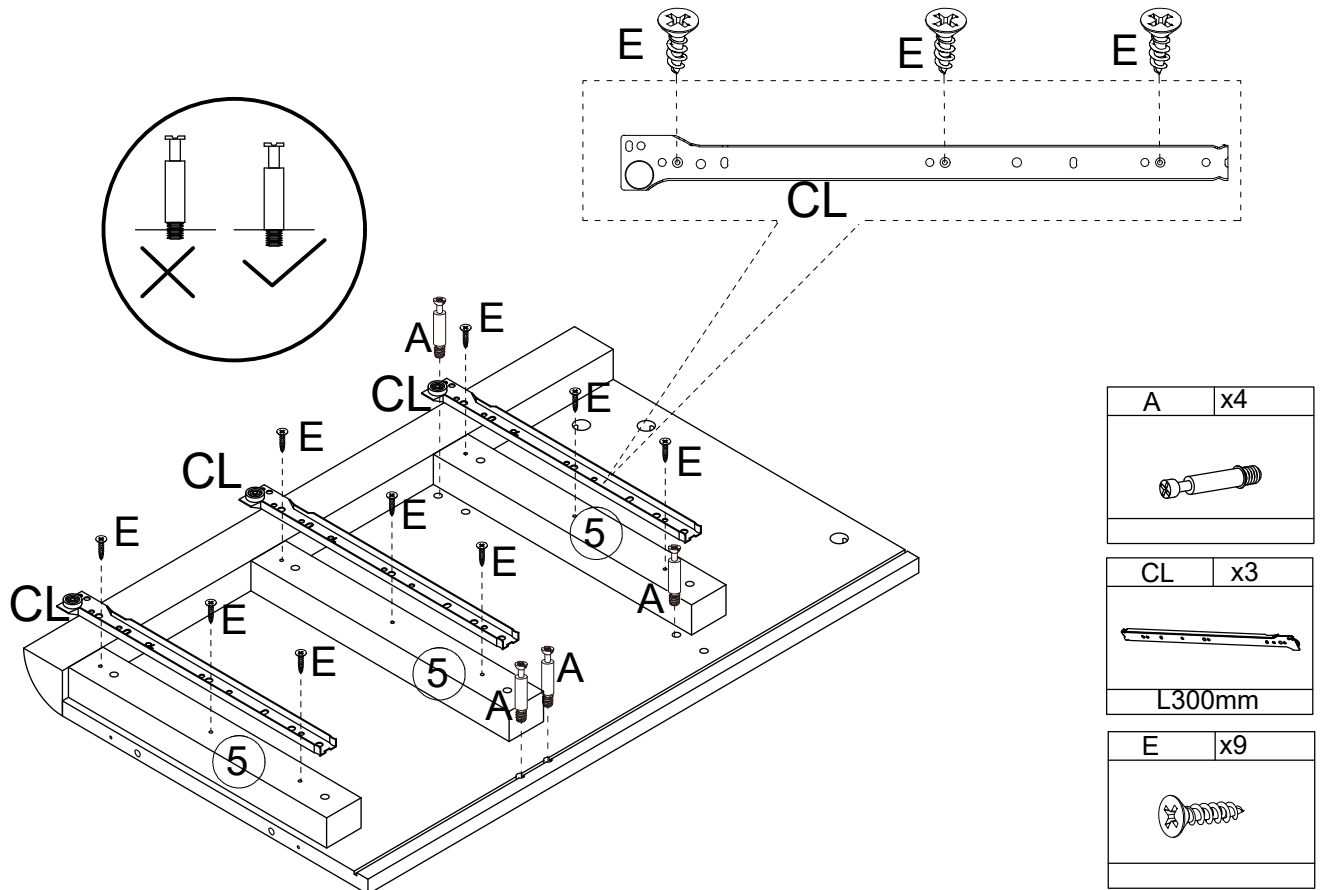

Use screws E(9 pcs) to fix the tracks CL(3 pcs) respectively on the 3 boards #5 in the direction shown in the figure, and screw A(4 pcs) into the corresponding positions, making sure they are fully screwed into board #1.

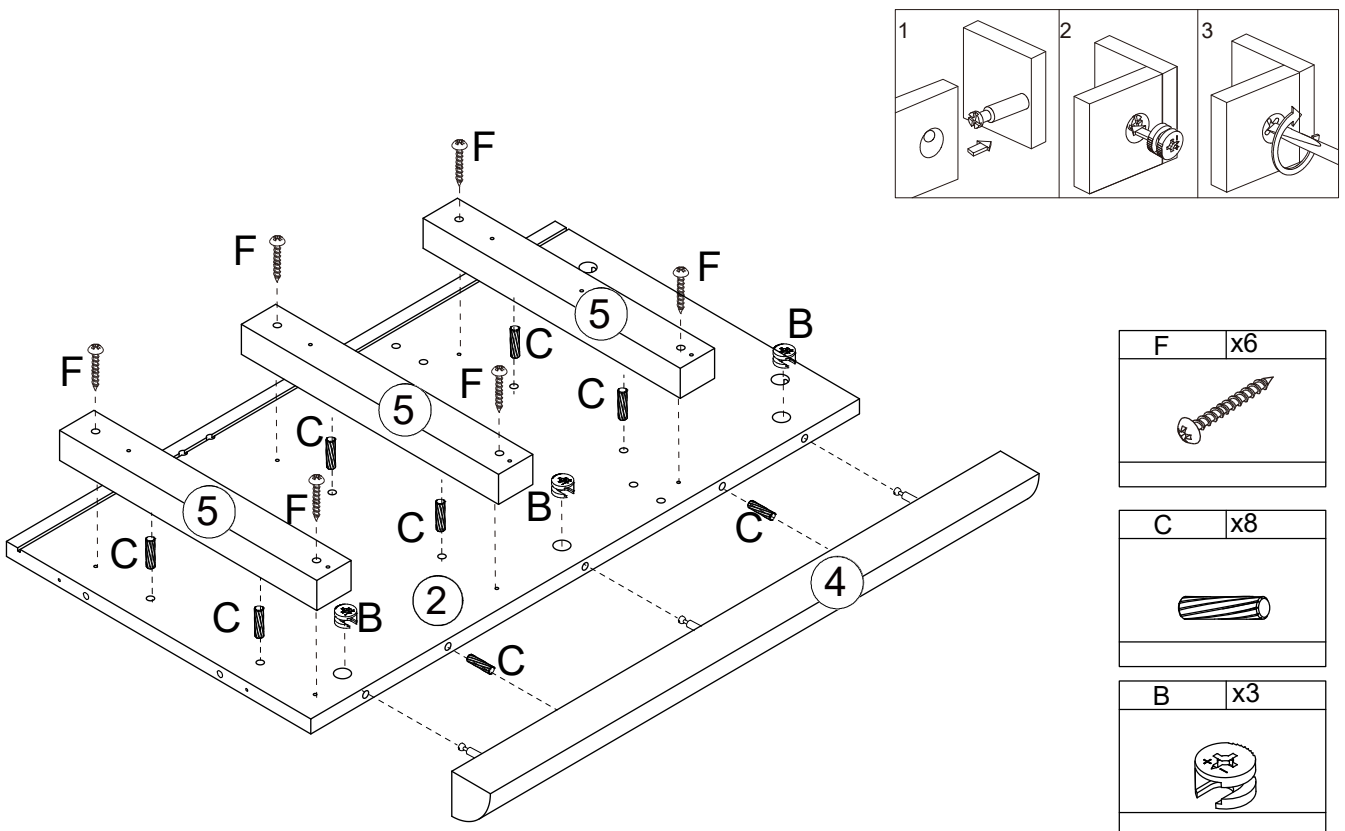

4

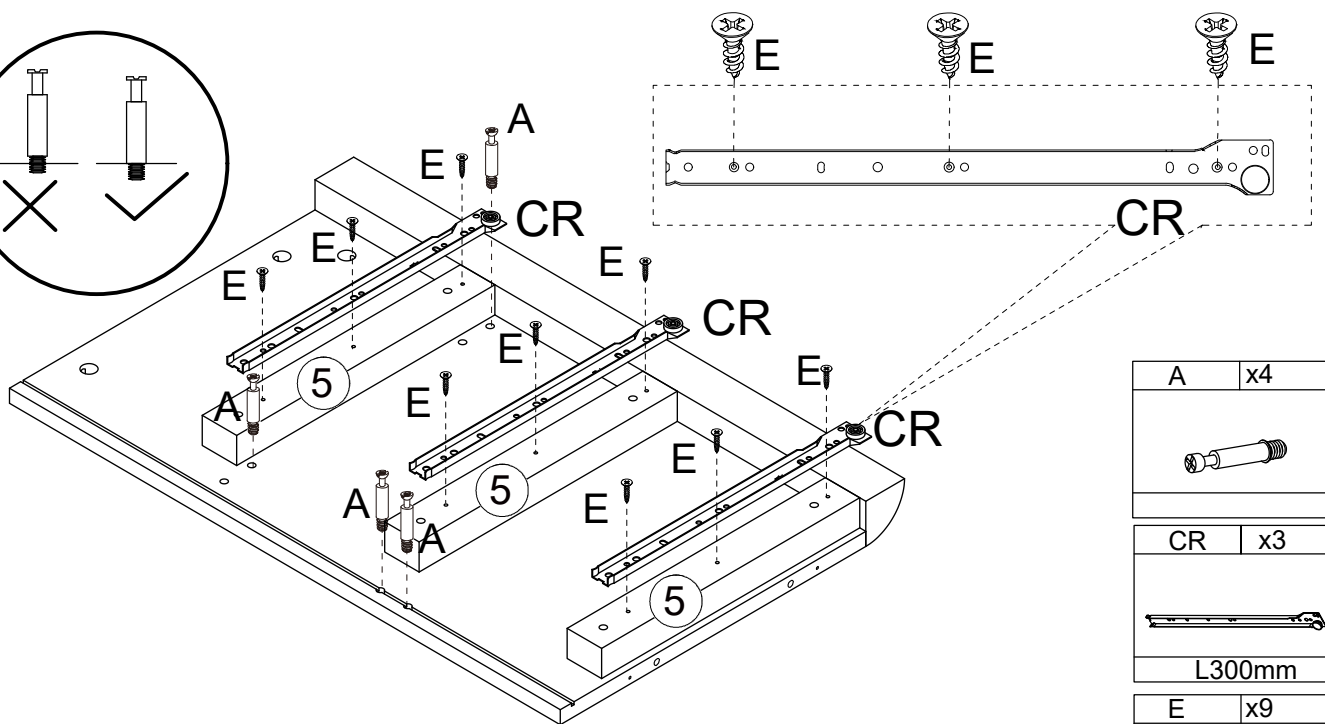
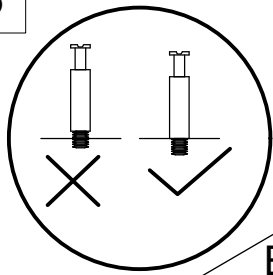

Take the other board #4 from the first step and board #2, and repeat the operation as per step 2. (Pay attention to distinguishing the direction of each part during the installation process.)

5

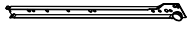



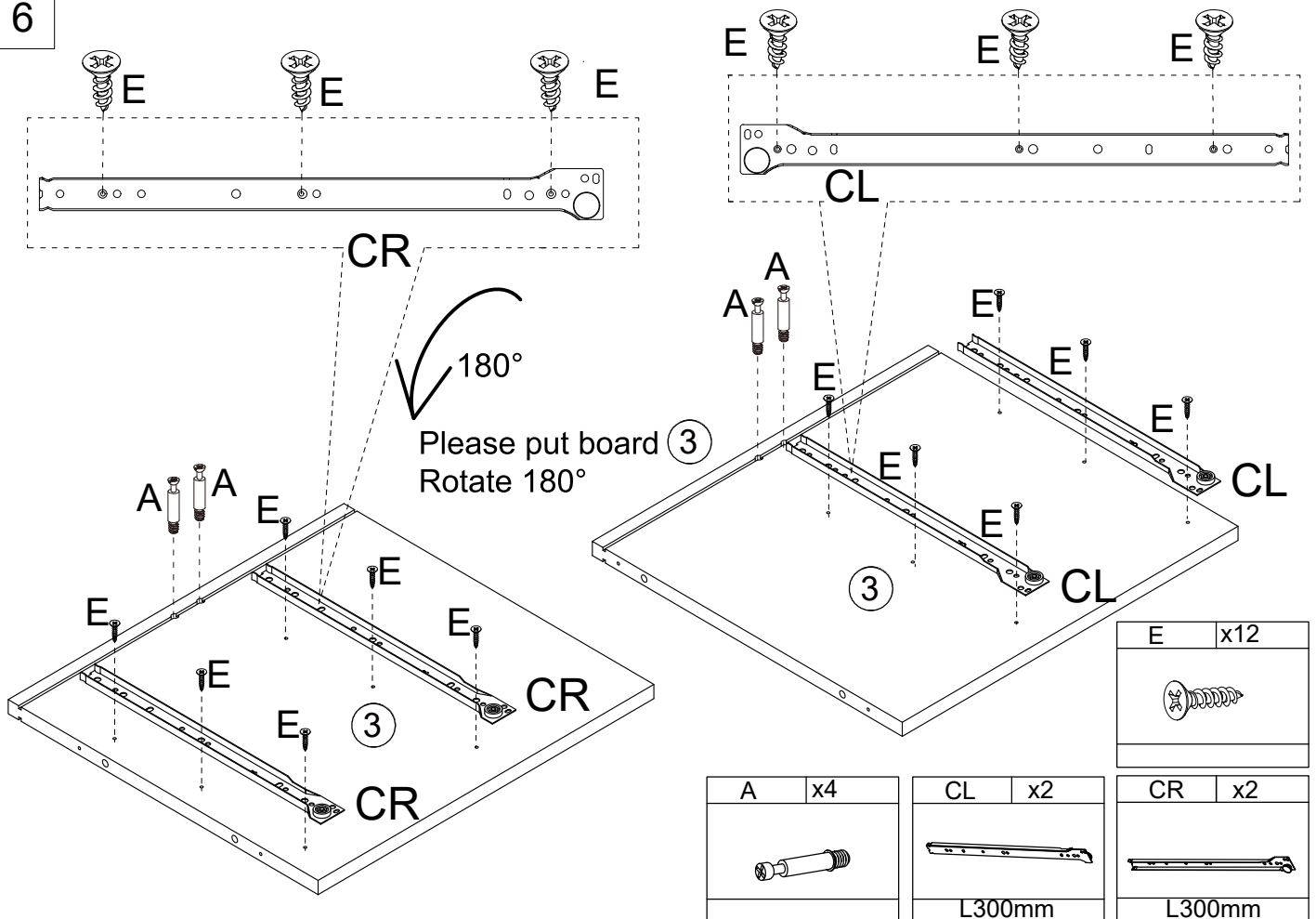

A	x4
	
CR	x3
	
L300mm	
E	x9
	

Use screws E(9 pcs) to fix the tracks CR(3 pcs) respectively on the 3 boards #5, and then fully screw bolt A (4 pcs) into the corresponding positions.

6



E	x12
	
A	x4
	
CL	x2
	
L300mm	
CR	x2
	
L300mm	

First, use screws E(6 pcs) to fix the tracks CL(2 pcs) onto board #3 in the direction shown in the diagram, and then fully screw bolt A(2 pcs) into the corresponding position of Board #3. Then flip it over to the other side of the board #3. Use the same operation to fix the track CR(2 pcs) on the board #3 with screws E(6 pcs), and screw bolt A(2 pcs) completely into the board #3. Note: Please be sure to identify the direction of Board #3.

7

X 2

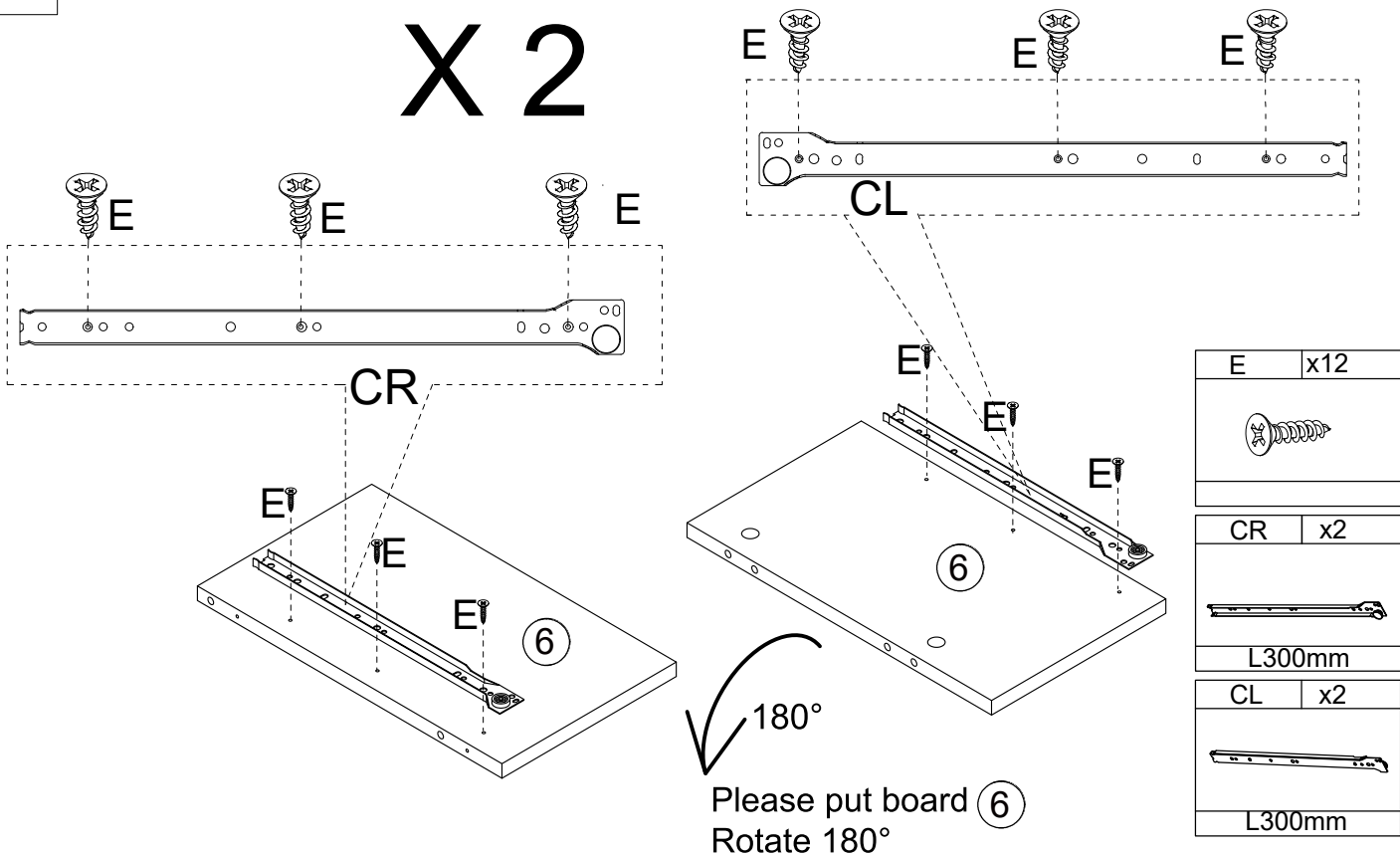

First, use screws E(3 pcs) to fix the tracks CL onto board #6 in the direction shown in the diagram. Then flip it over to the other side of the board #6. Use the same operation to fix the track CR on the board #6 with screws E(3 pcs). Note: Please be sure to identify the direction of Board #6 and the track CL,CR.

8

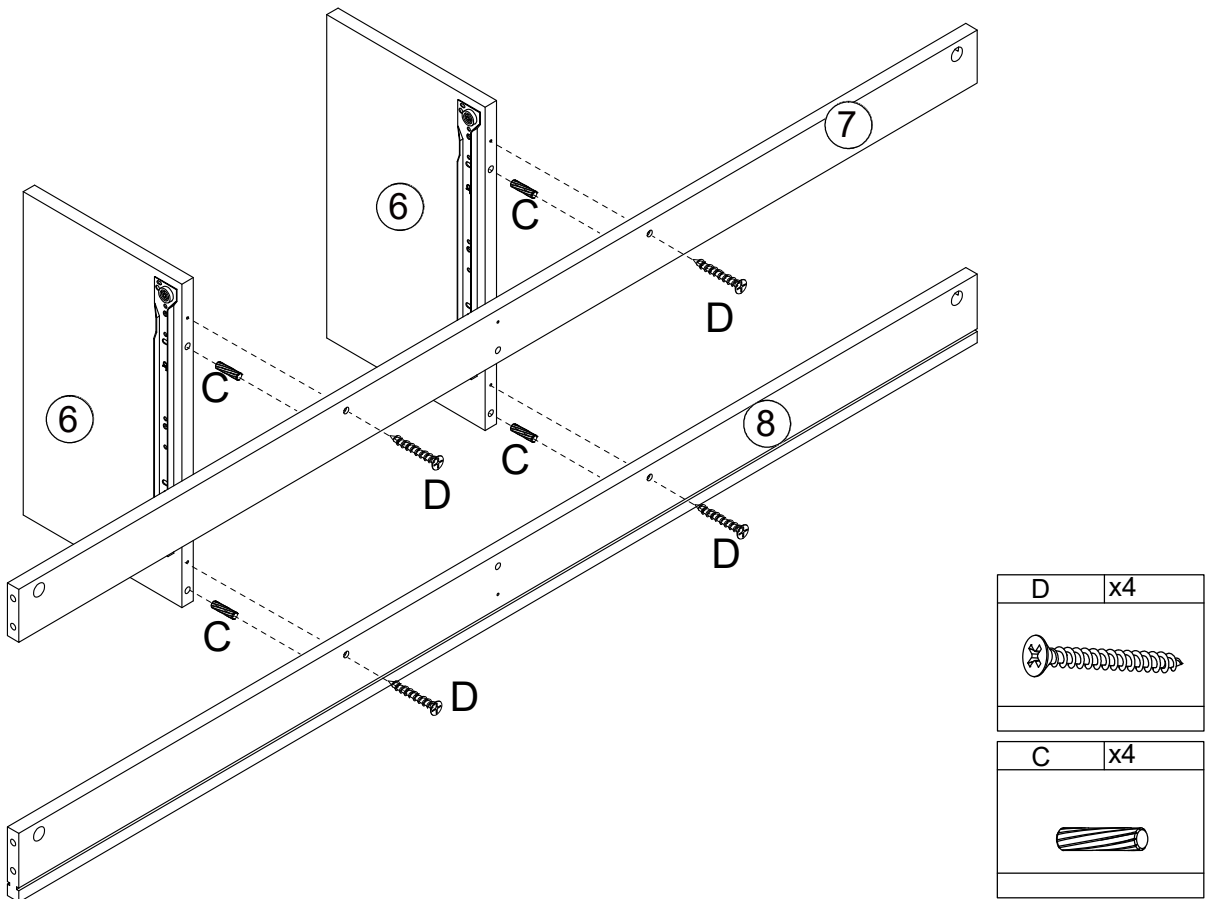

Connect board #7 to 2 boards #6 using cork C (2 pcs) and tighten them with screw D (2 pcs). The same operation fixes board #8 to the unit component.

9

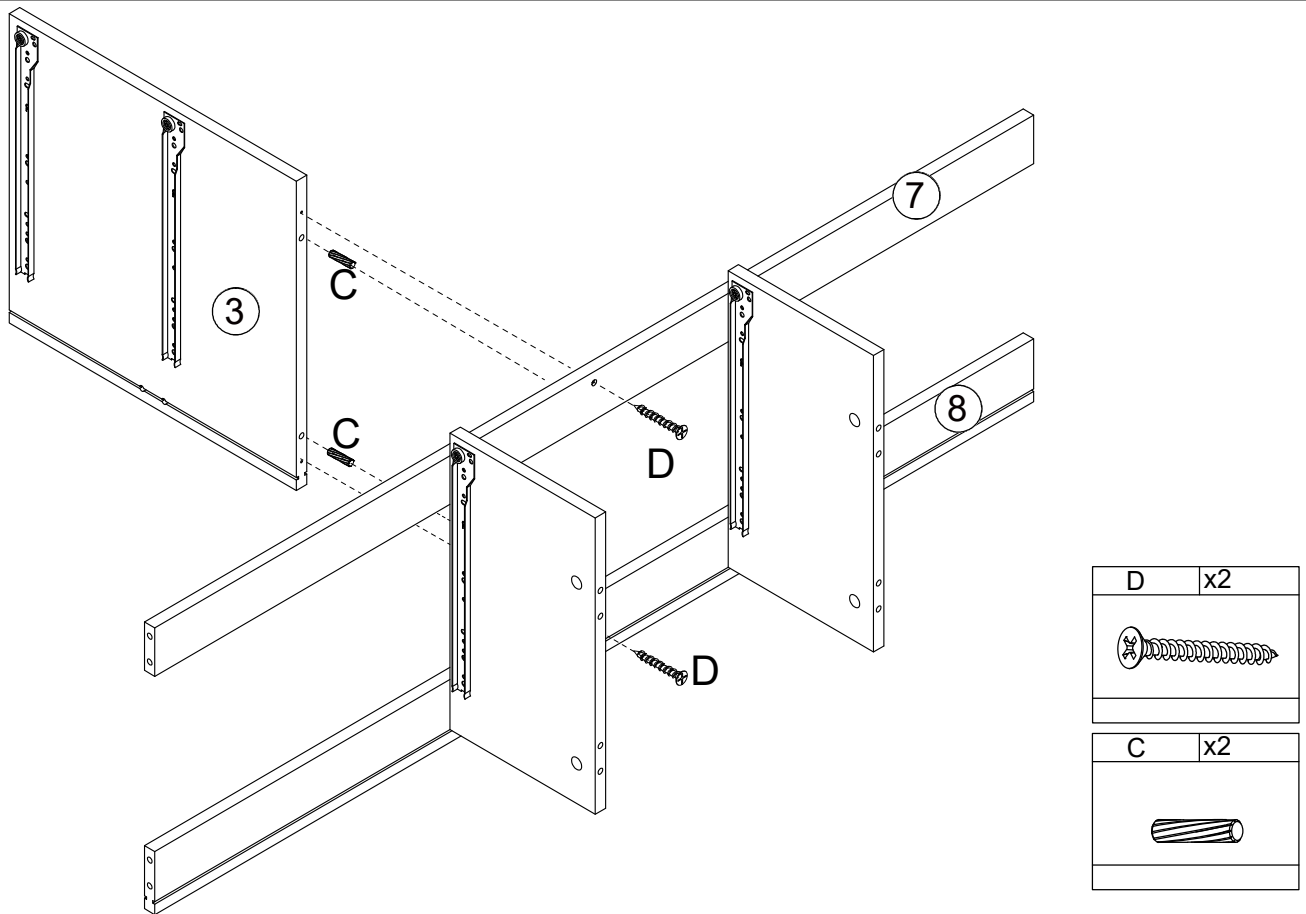

Connect board #3 to the unit completed in the previous step using cork C (2 pcs) and tighten them with screw D (2 pcs).

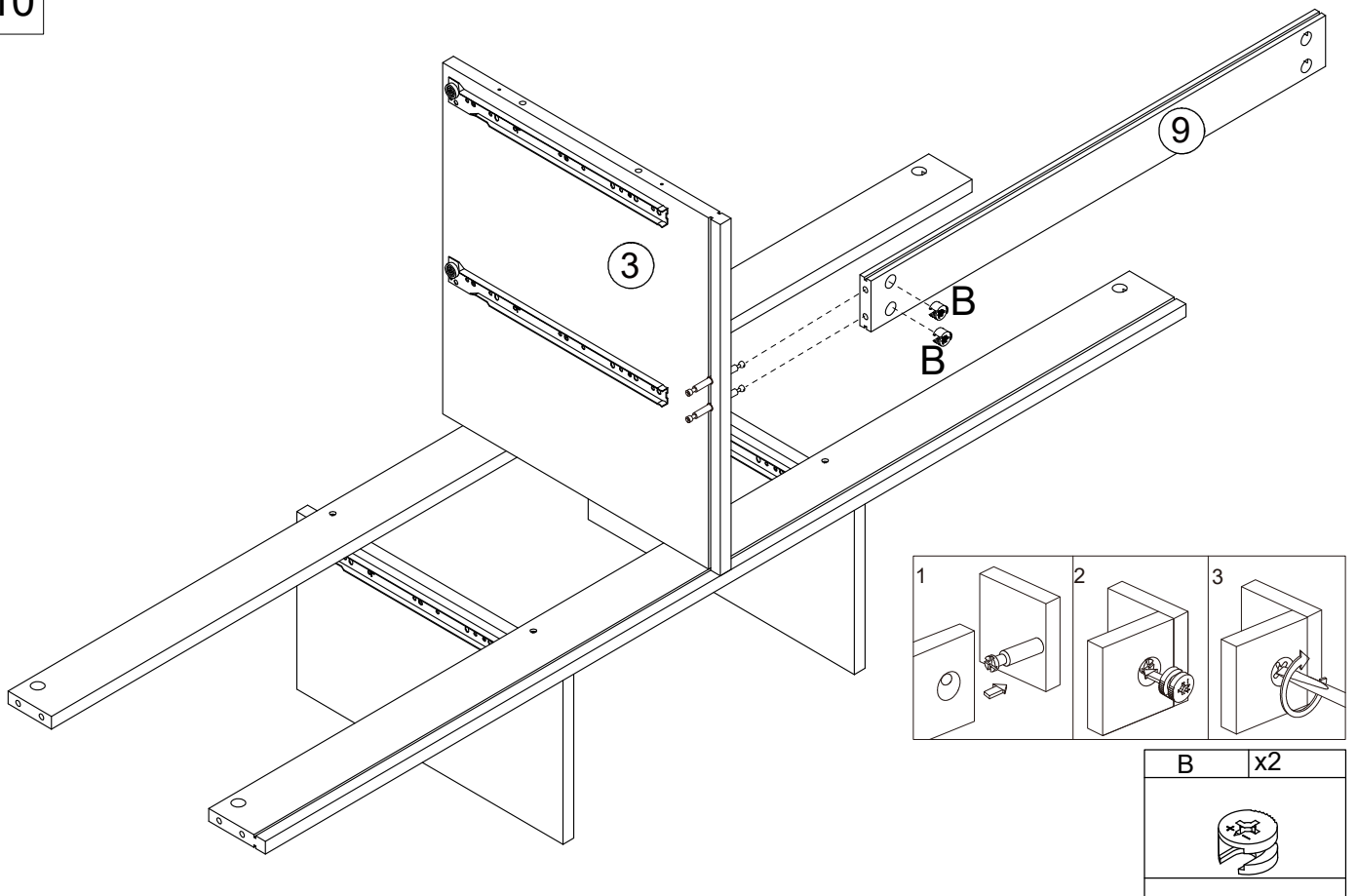

10

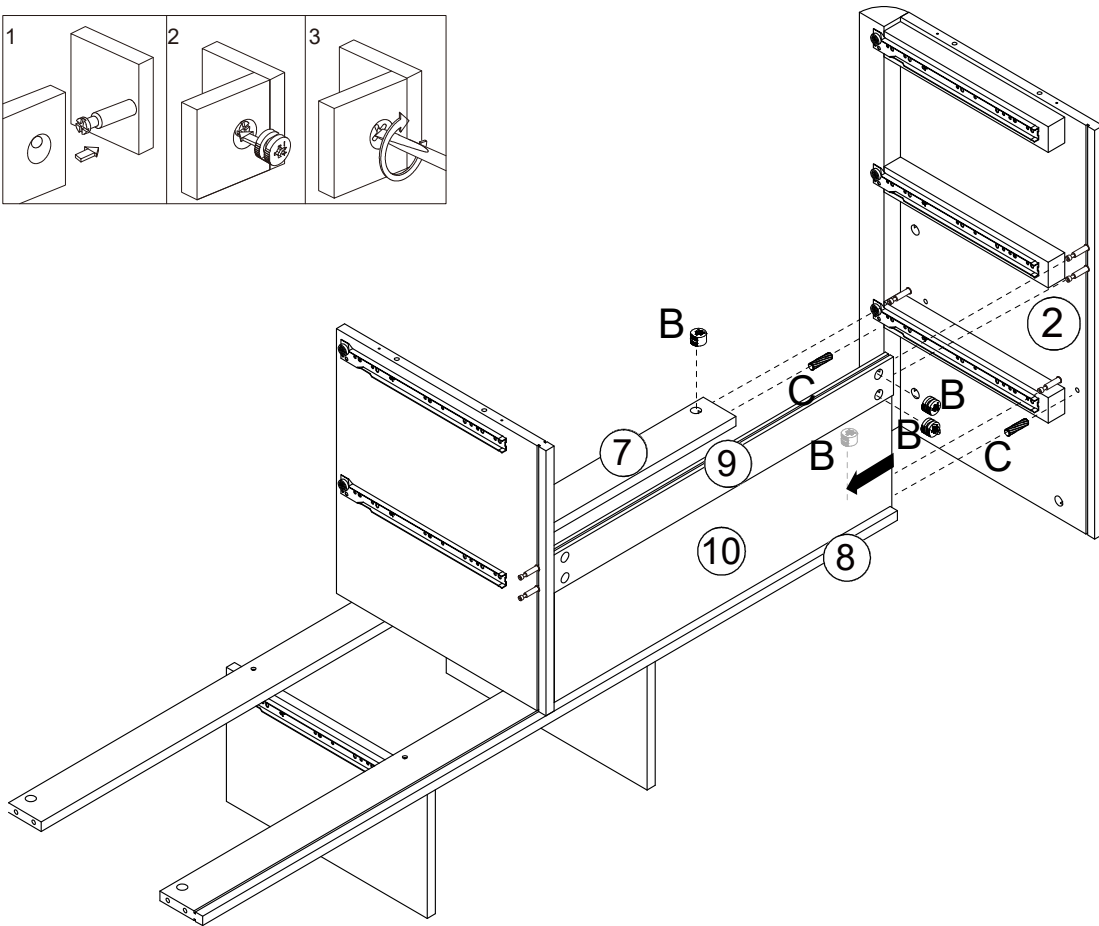
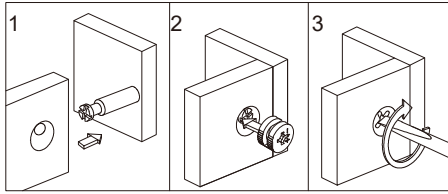

Align the side holes of Board #9 with the two screws A on the unit and tighten and fix them with lock B (2 pcs).

11



C	x2
	
B	x4
	

Insert the boards #10 into the finished unit along the prefabricated track in the direction shown. Use cork C (2 pc) and lock B (4 pcs) at the same time to secure board #2 to the boards #7,#8,#9.

12

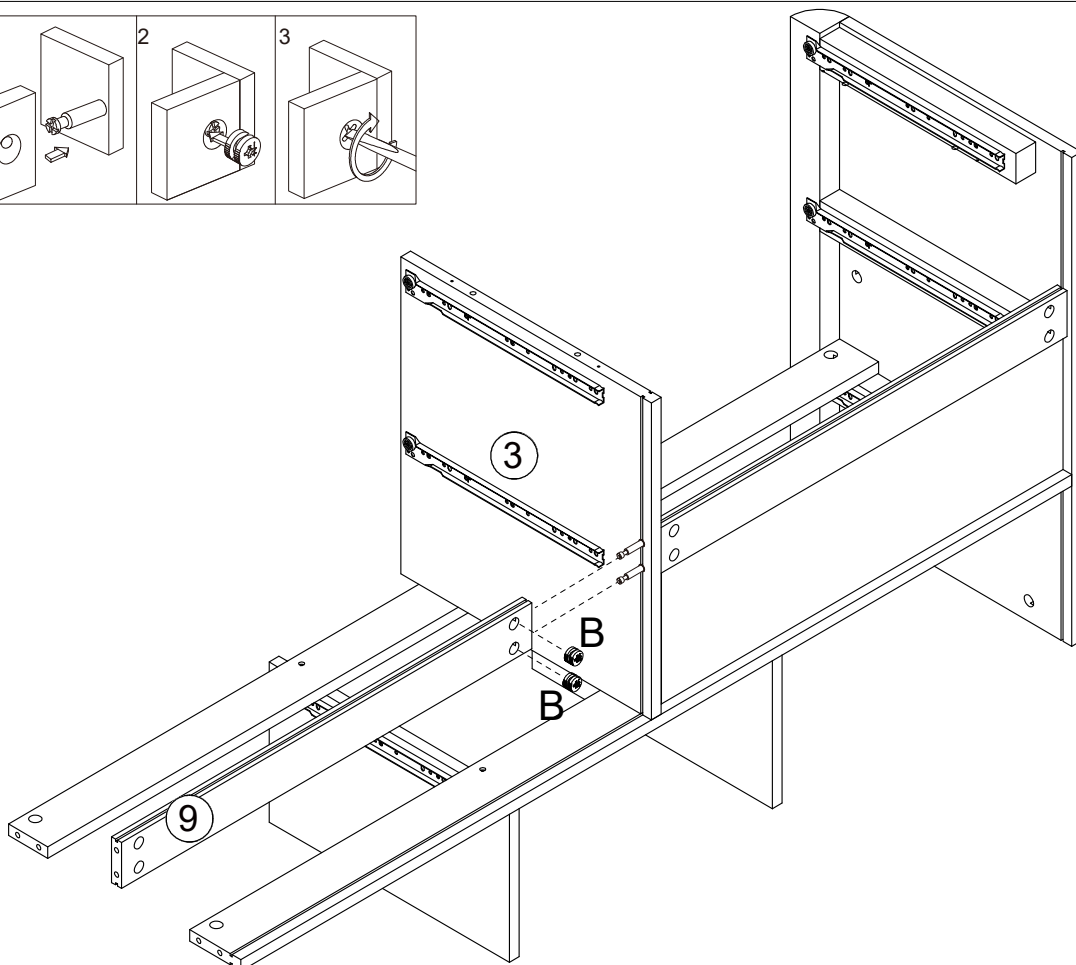
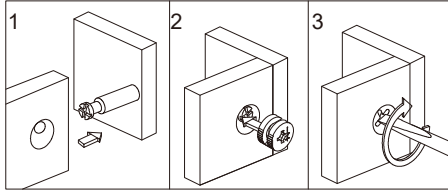

B	x2
	

Align the side holes of Board #9 with the two screws A on the unit and tighten and fix them with lock B (2 pcs).

13

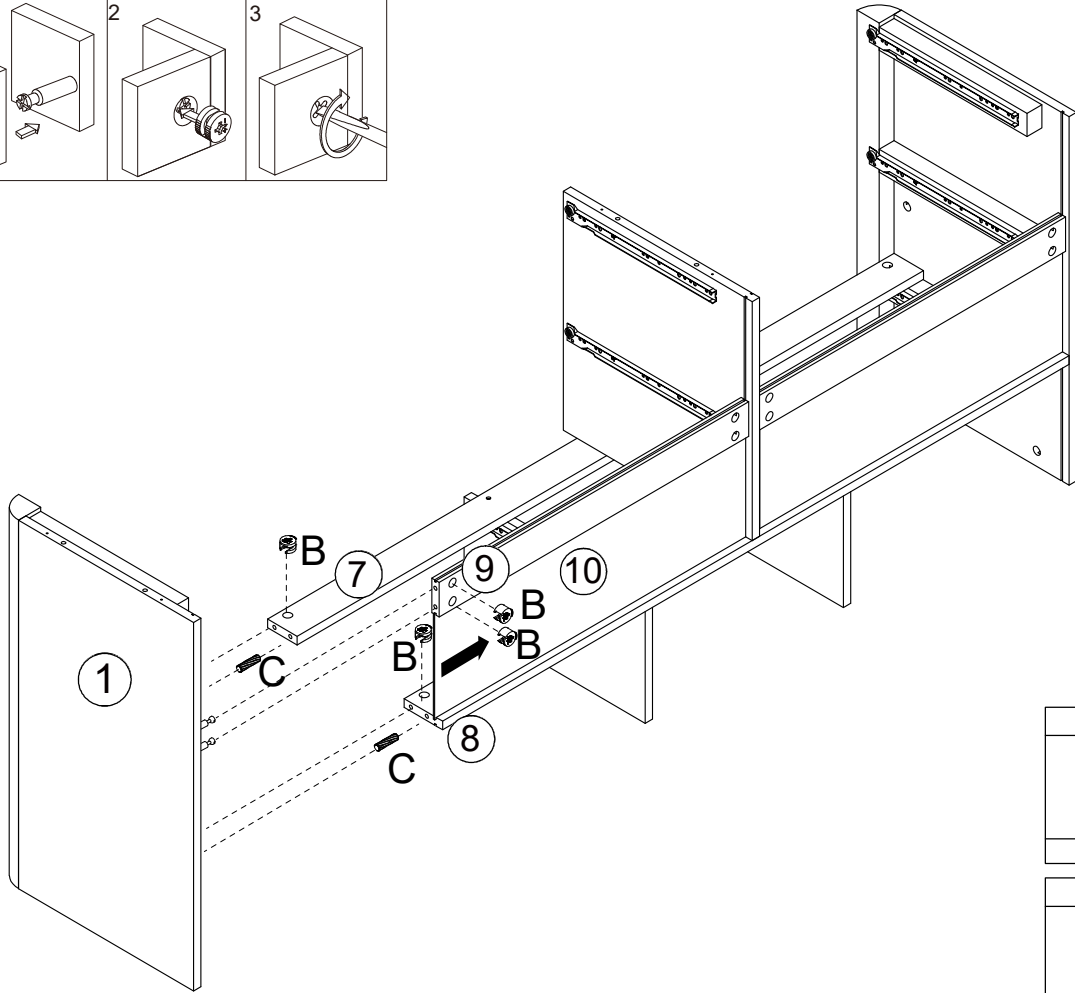
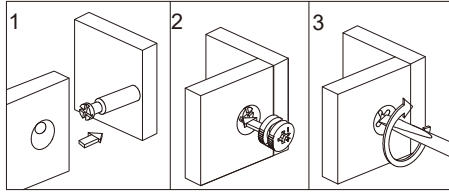

C	x2
B	x4

This step is the same as the operation in Step 11.

14

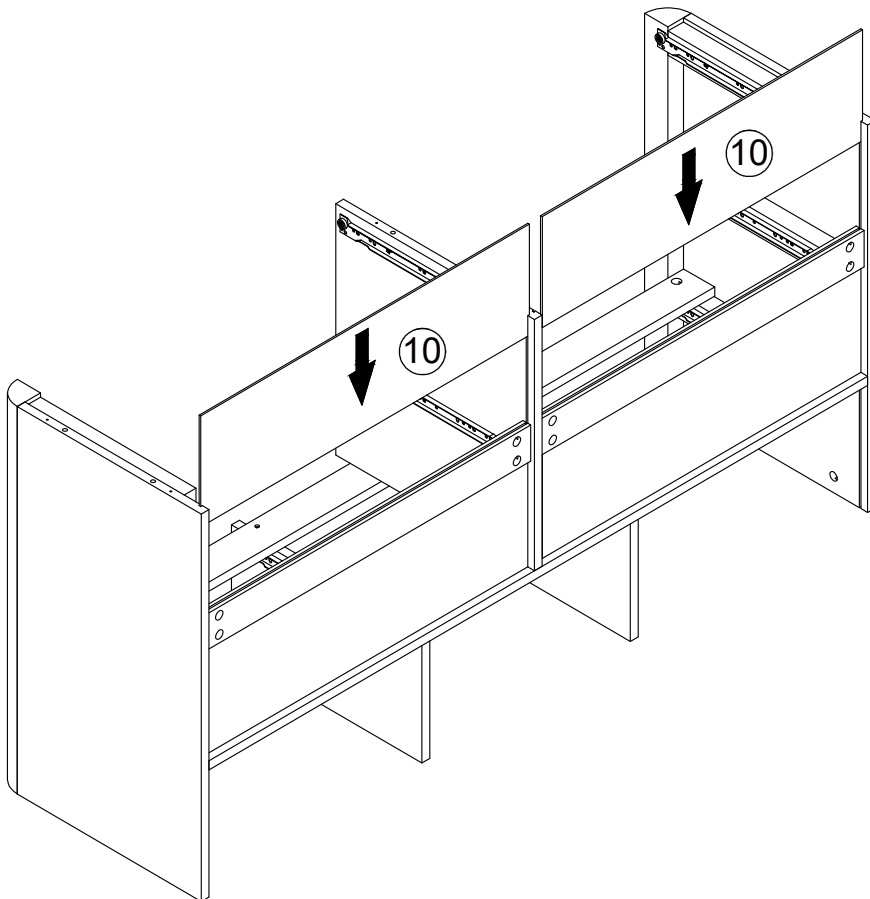

Insert the boards #10 (2 pcs) into the finished unit along the prefabricated track in the direction shown.

15

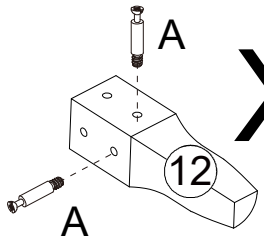
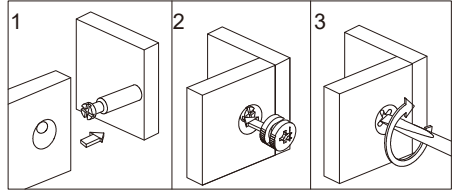
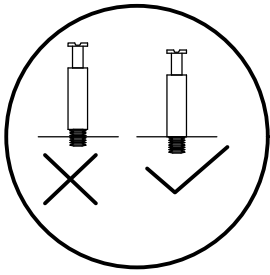

X 4

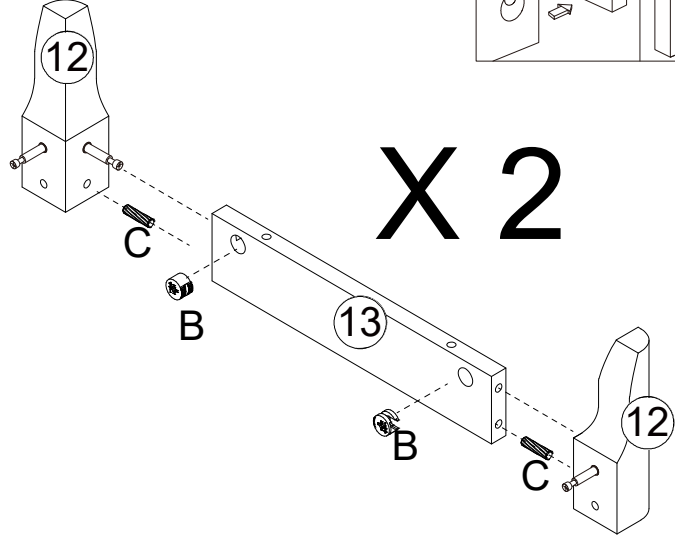

X 2

C	x4
B	x4
A	x8

Screw A (2 pcs) into the cabinet foot #12 completely as shown in the diagram, and repeat this operation a total of 4 times.

Use one lock B and one cork C to fix one cabinet foot #12 to the board #13. Perform the same operation on the other side to finally fix two cabinet feet #12 to one board #13. This operation is repeated a total of 2 times.

16

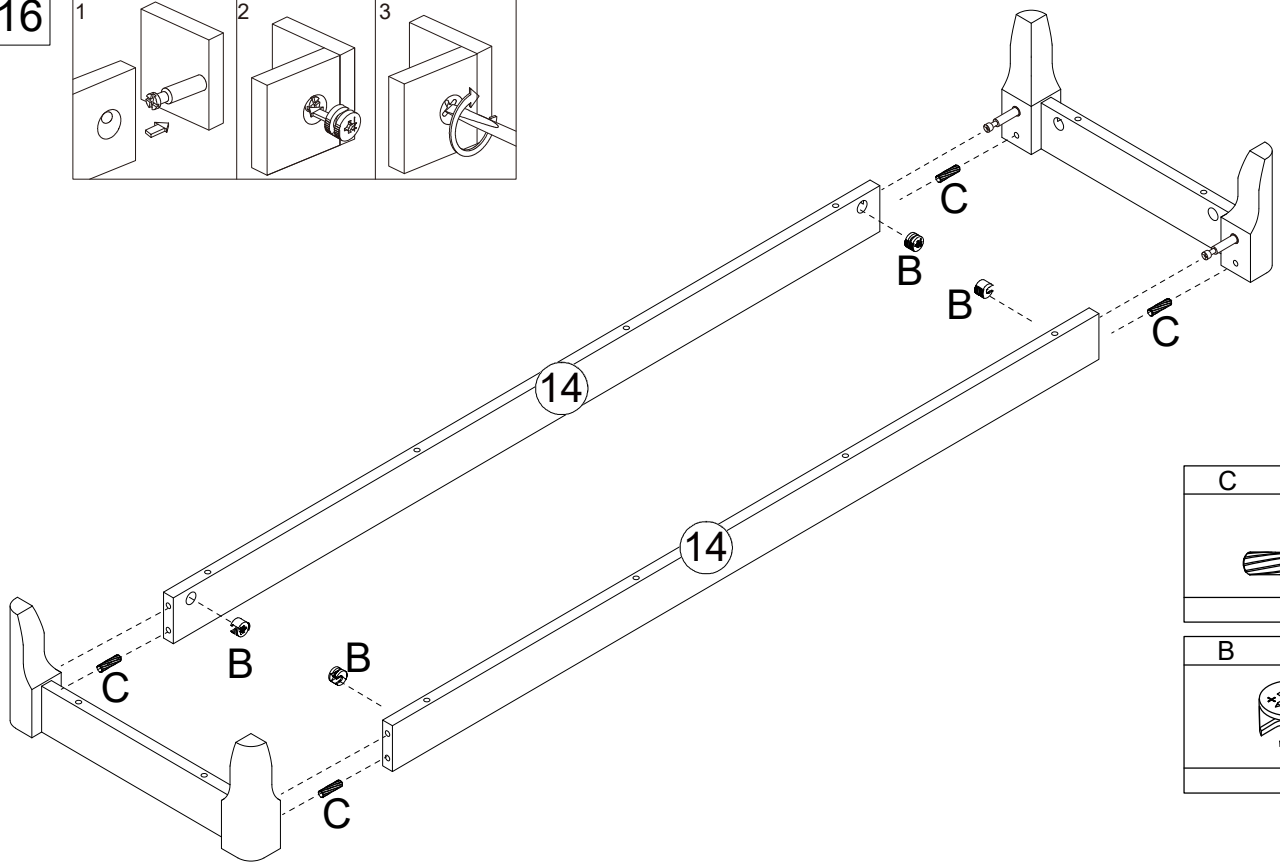
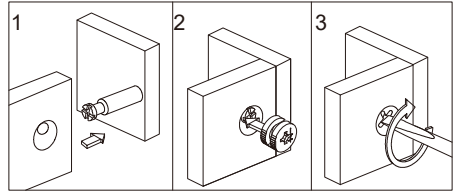

C	x4
B	x4

Screw A (2 pcs) into the cabinet foot #12 completely as shown in the diagram, and repeat this operation a total of 4 times.

Use one lock B and one cork C to fix one cabinet foot #12 to the board #13. Perform the same operation on the other side to finally fix two cabinet feet #12 to one board #13. This operation is repeated a total of 2 times.

17

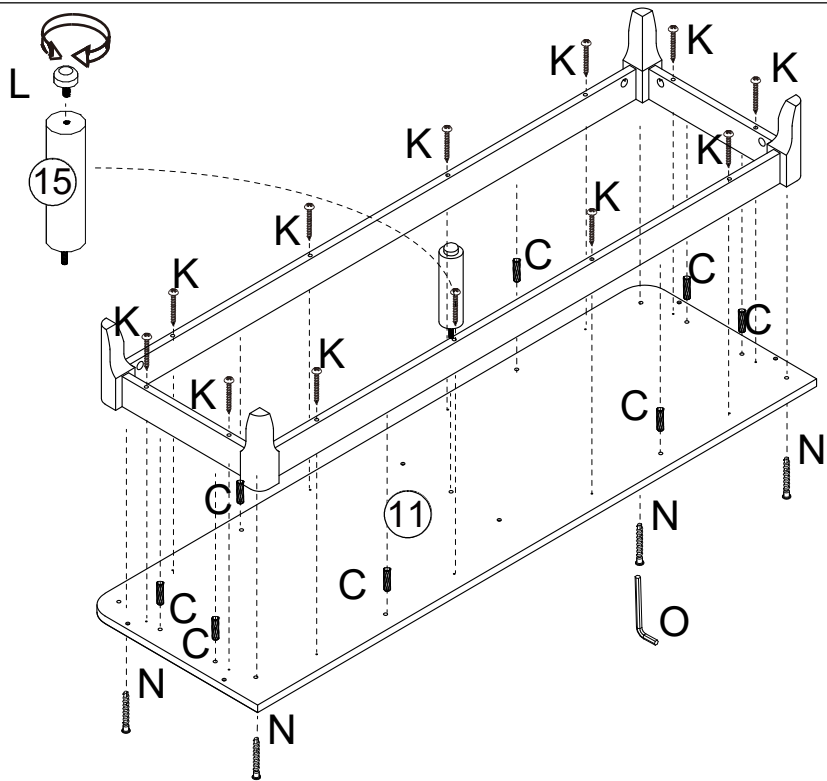

O	x1
N	x4
C	x8
L	x1
K	x12

First, connect the completed base and board #11 with cork C (8 pcs) as shown in the diagram. Then, tighten the screws K (12 pcs) from the base and the screws N (4 pcs) from the board #11. Screw the foot pad L into adjusting foot #15, and then screw them into the corresponding positions on the board #11.

18

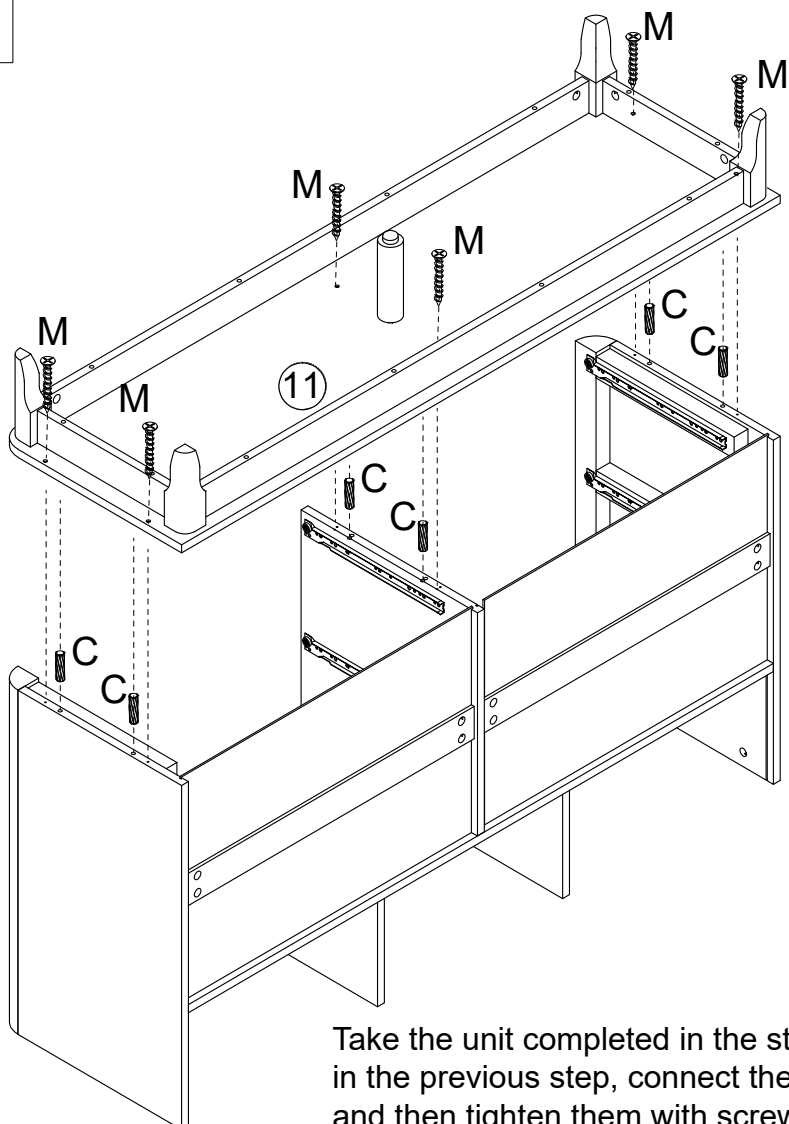

C	x6
M	x6

Take the unit completed in the step 14 and the unit completed in the previous step, connect them with cork C (6 pcs) respectively, and then tighten them with screw M (6 pcs) to finally complete the fixation.

19

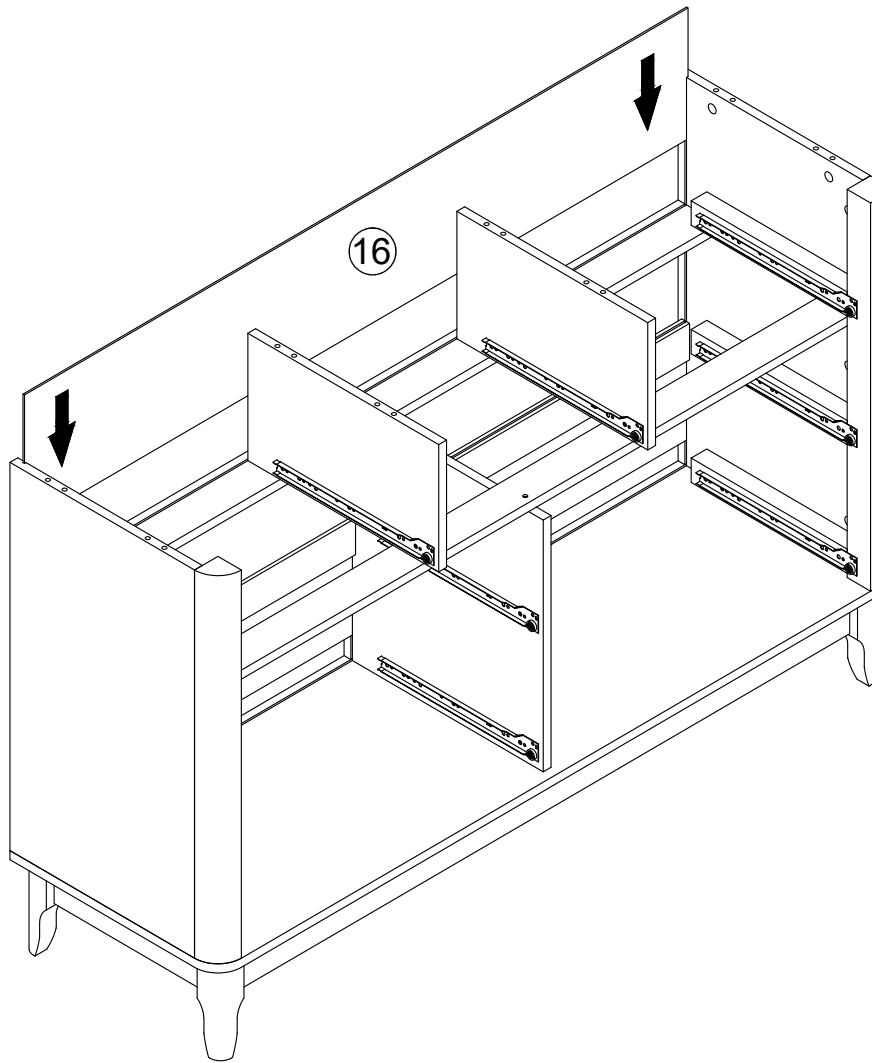

Turn the cabinet upside down and place it facing up. Insert the boards #16 into the finished unit along the prefabricated track in the direction shown.

20

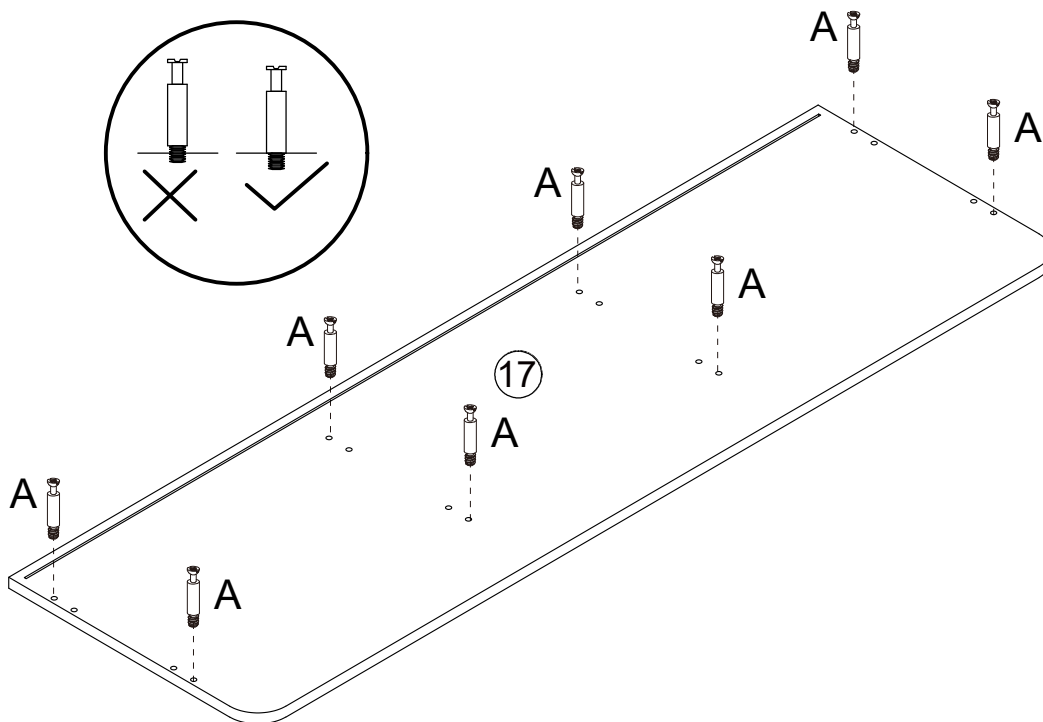

Screw bolt A (8 pcs) completely into the correct position on the board #17.

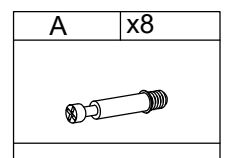

21

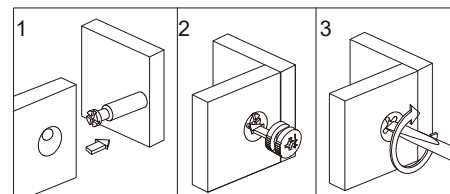
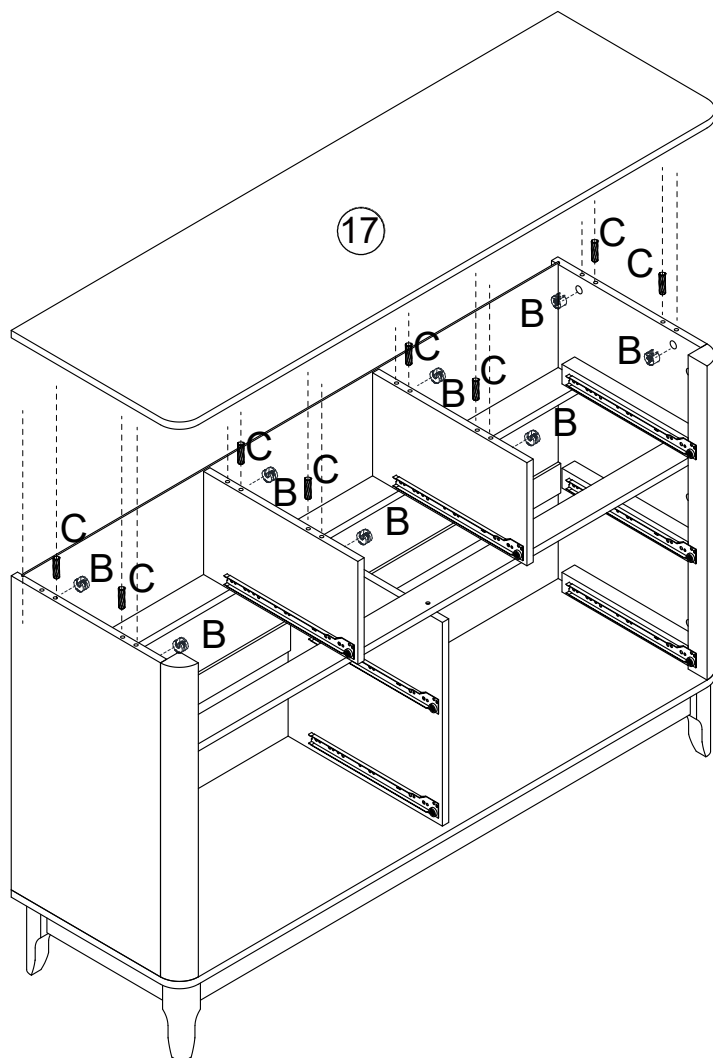

C	x8
B	x8

At the same time, use the corks C (8 pcs) and the screw A on board #17 to align with the correct holes on the completed cabinet structure and connect them. Then, tighten and fix them with the bolts B (8 pcs).

22

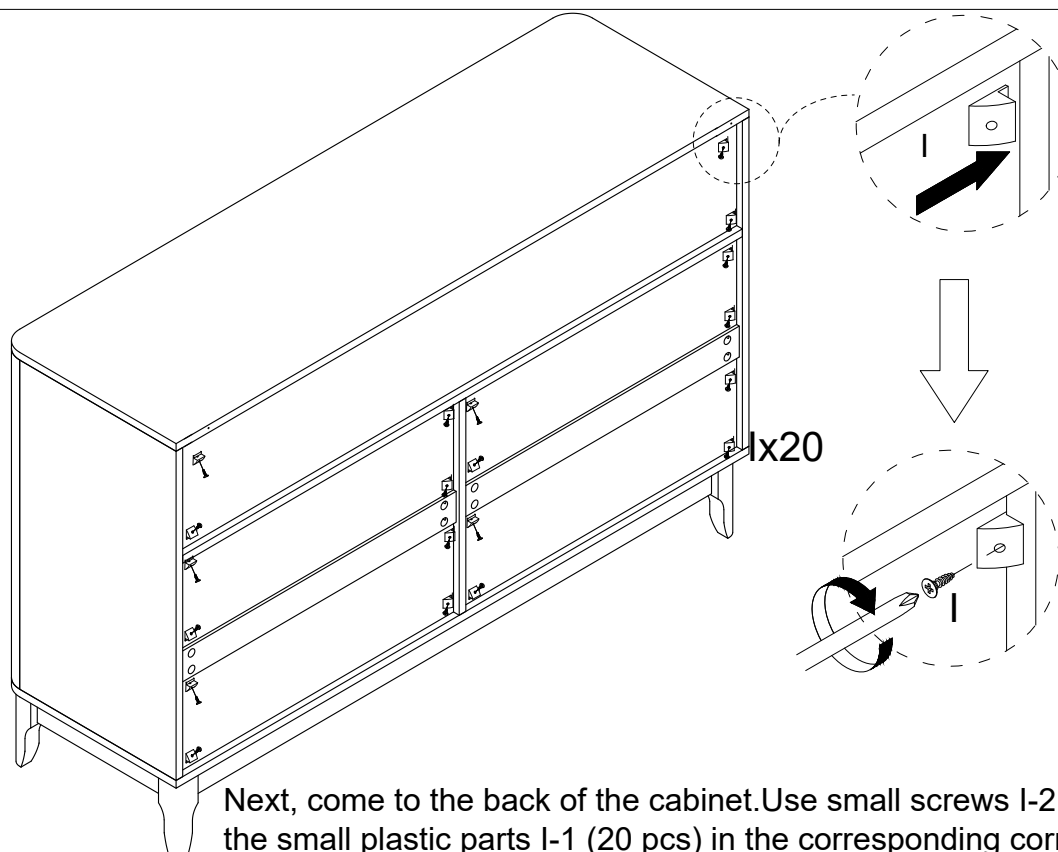

I	x20

Next, come to the back of the cabinet. Use small screws I-2 (20 pcs) to tighten the small plastic parts I-1 (20 pcs) in the corresponding corners of the back plate to reinforce the cabinet.

23

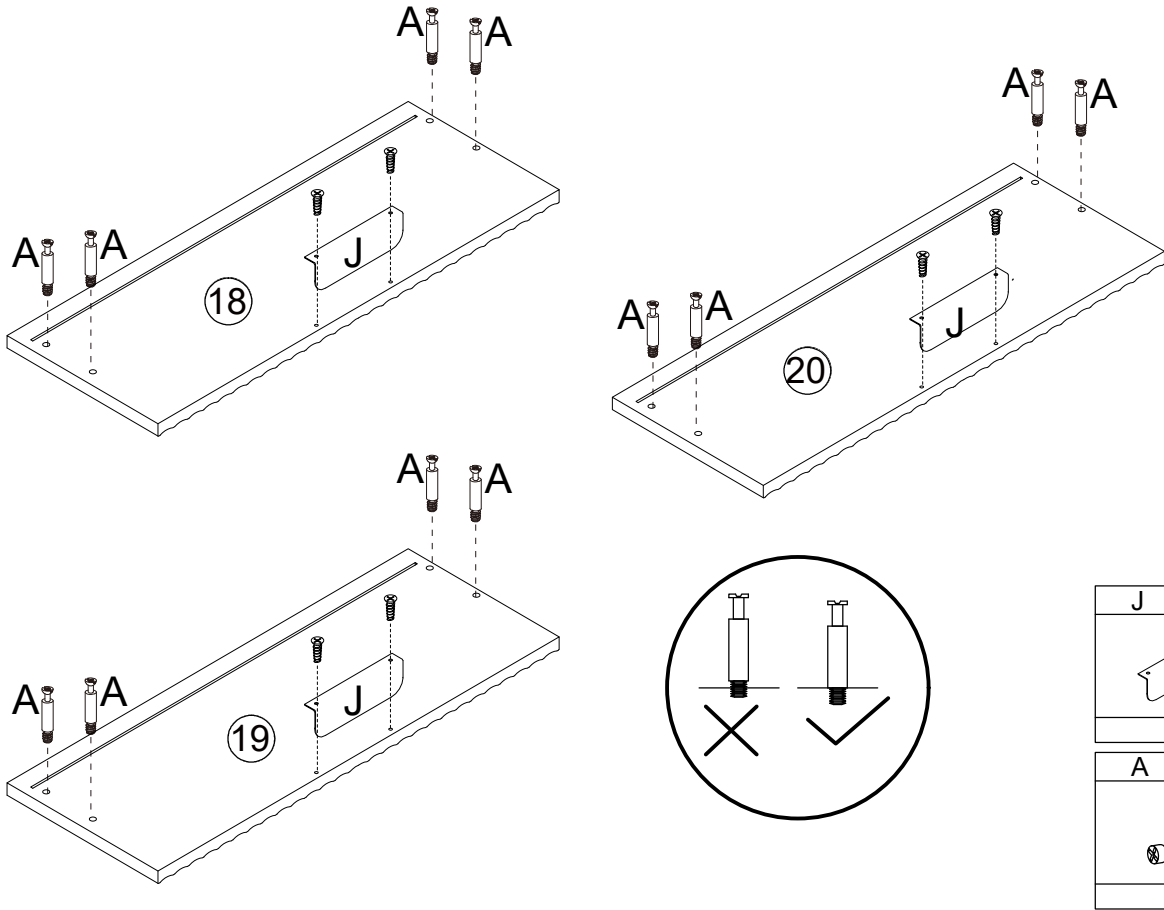

Fully screw bolt A (4 pcs) into Board #18 (or Board #19, #20), and use the corresponding screws to fix handle J to board #18 (or Board #19, #20).

24

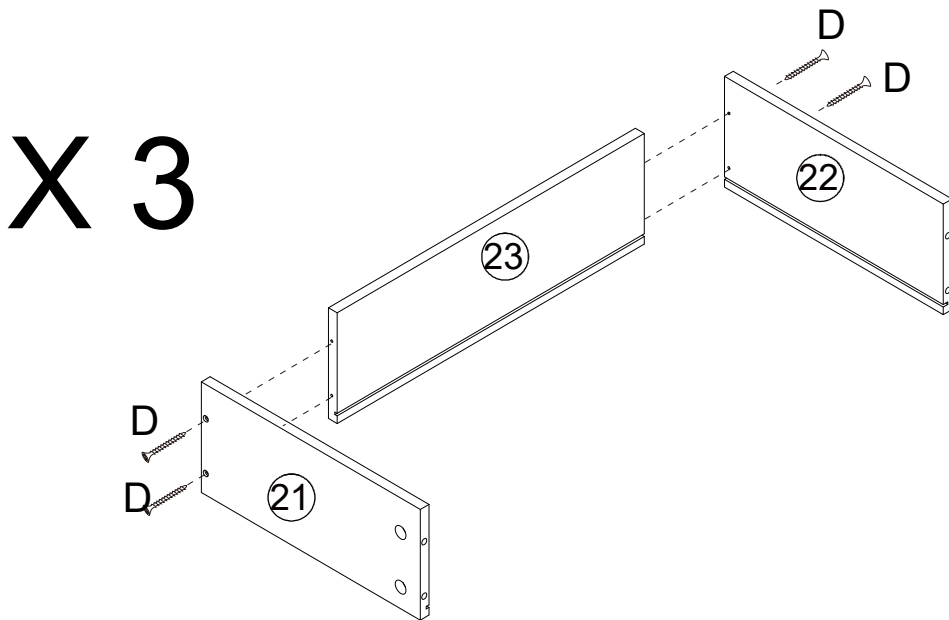

Fix the boards #21, #22, and #23 with screws D (4 pcs) as shown in the diagram. The same operation needs to be completed 3 times. (Pay attention to align the track when installing to avoid reversing the direction of the boards)

D	x12
	

X 3

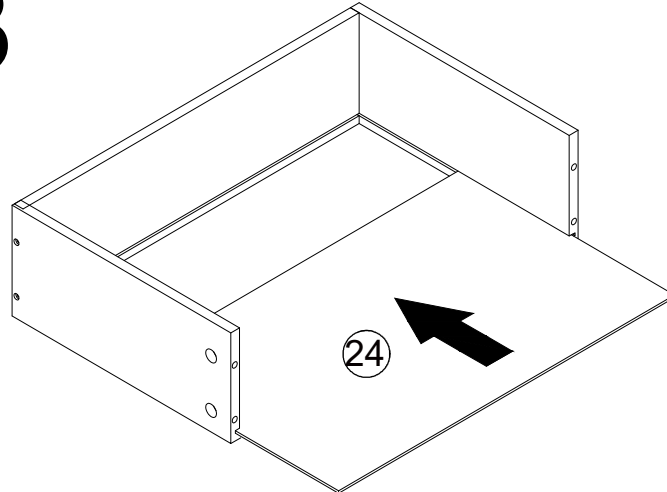

Insert the boards #24 into the finished unit along the prefabricated track in the direction shown. The same operation needs to be completed 3 times.

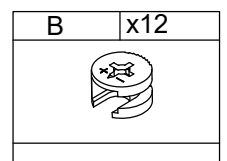
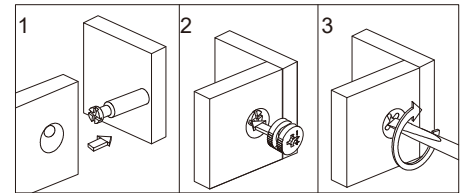
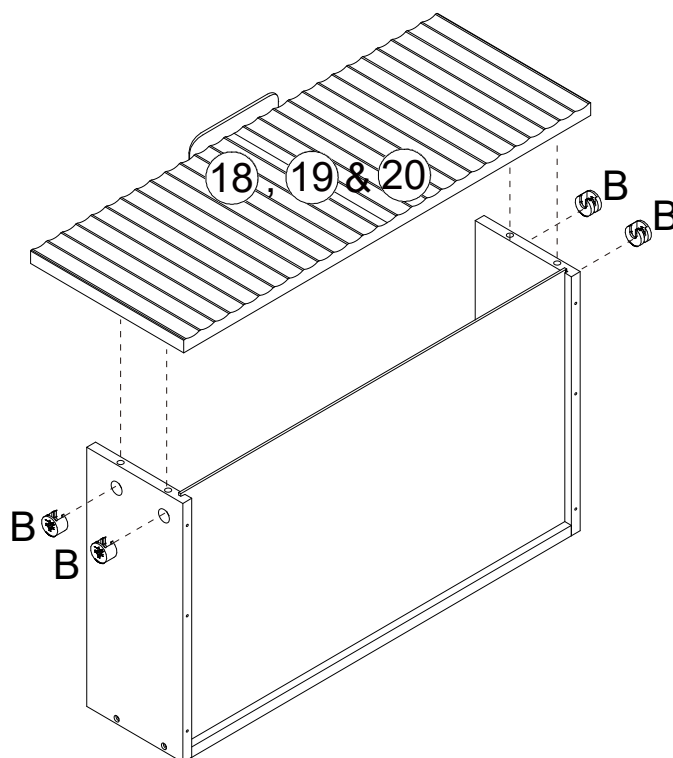

Align screw A on Board #18 or #19 or #20 with the holes on the drawer units and insert them, then fix them with lock B (4 pcs). Repeat the same operation to complete the assembly of 3 small drawers.

27

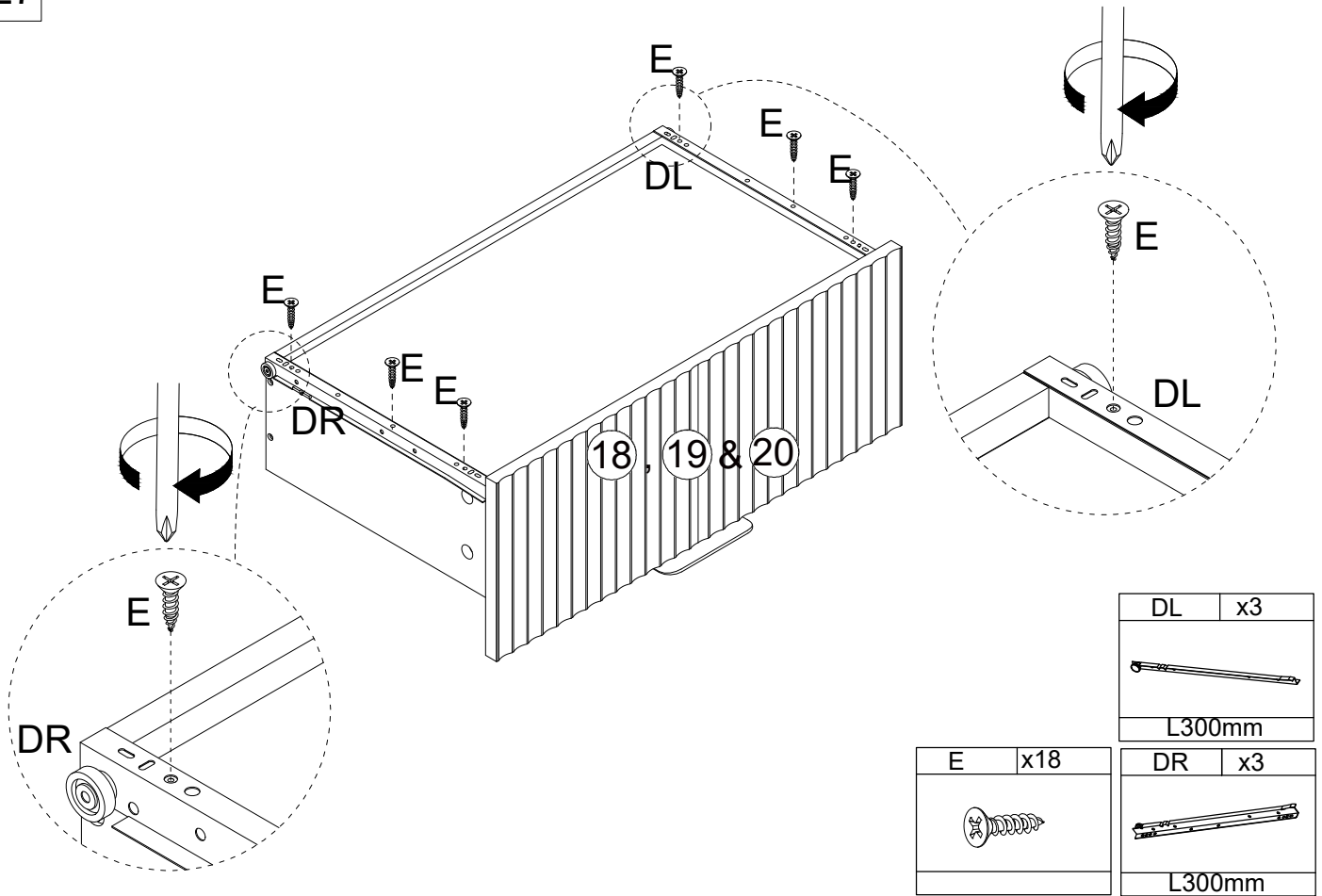

Align the tracks DR and DL correctly with the prefabricated holes at the bottom of the drawer (pay attention to the detailed markings in the illustration), and fix them with screws E (6 pcs). This operation needs to be completed 3 times.

28

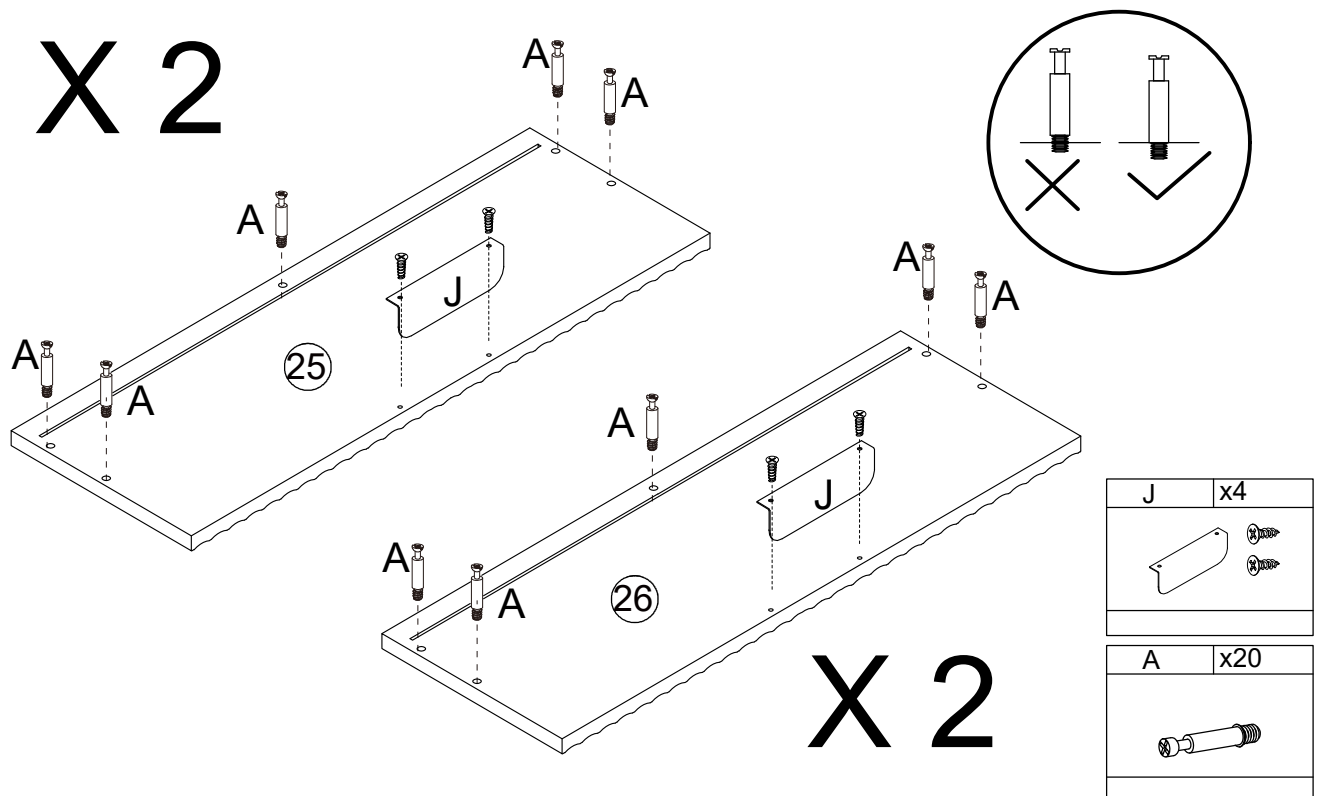

Fully screw bolt A (5 pcs) into board #25 (or board #26), and use the corresponding screws to fix handle J to board #25 (or board #26). The same operation was performed a total of 4 times.

31

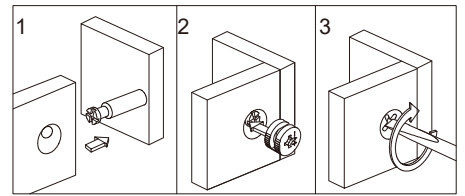
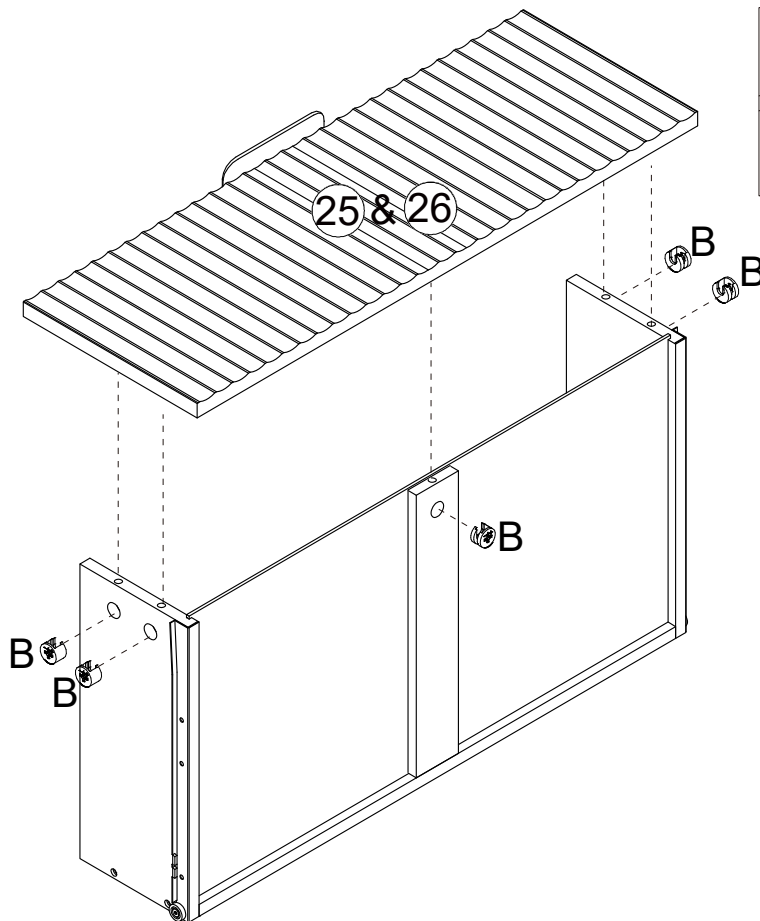

X 2

B	x20
	

Align screw A on Board #25 or #26 with the holes on the drawer units and insert them, then fix them with lock B (5 pcs). Repeat the same operation to complete the assembly of 4 large drawers.

32

X 2

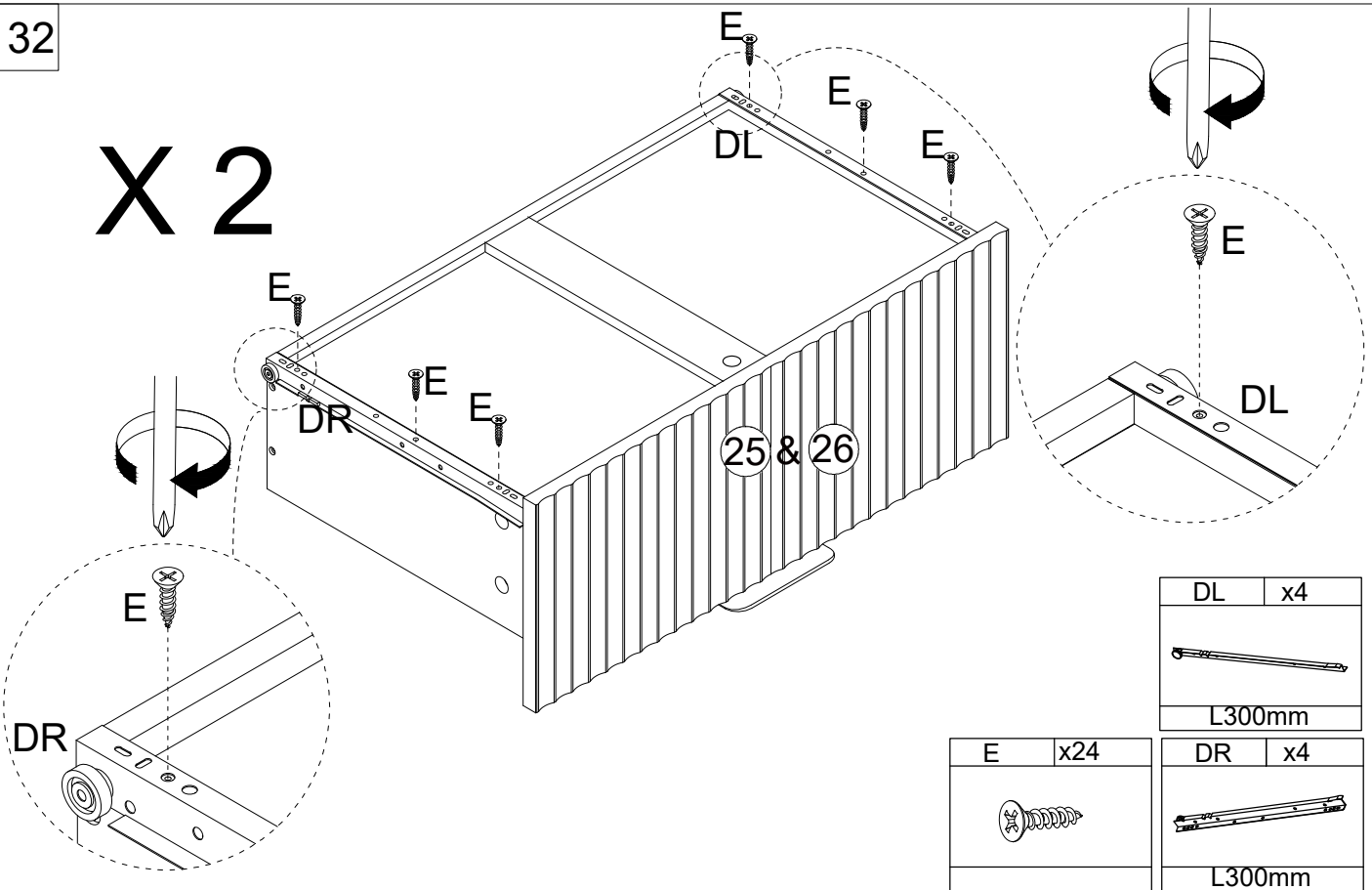

DL	x4
	
L300mm	

E	x24
	

DR	x4
	
L300mm	

Align the tracks DR and DL correctly with the prefabricated holes at the bottom of the drawer (pay attention to the detailed markings in the illustration), and fix them with screws E (6 pcs). This operation needs to be completed 4 times.

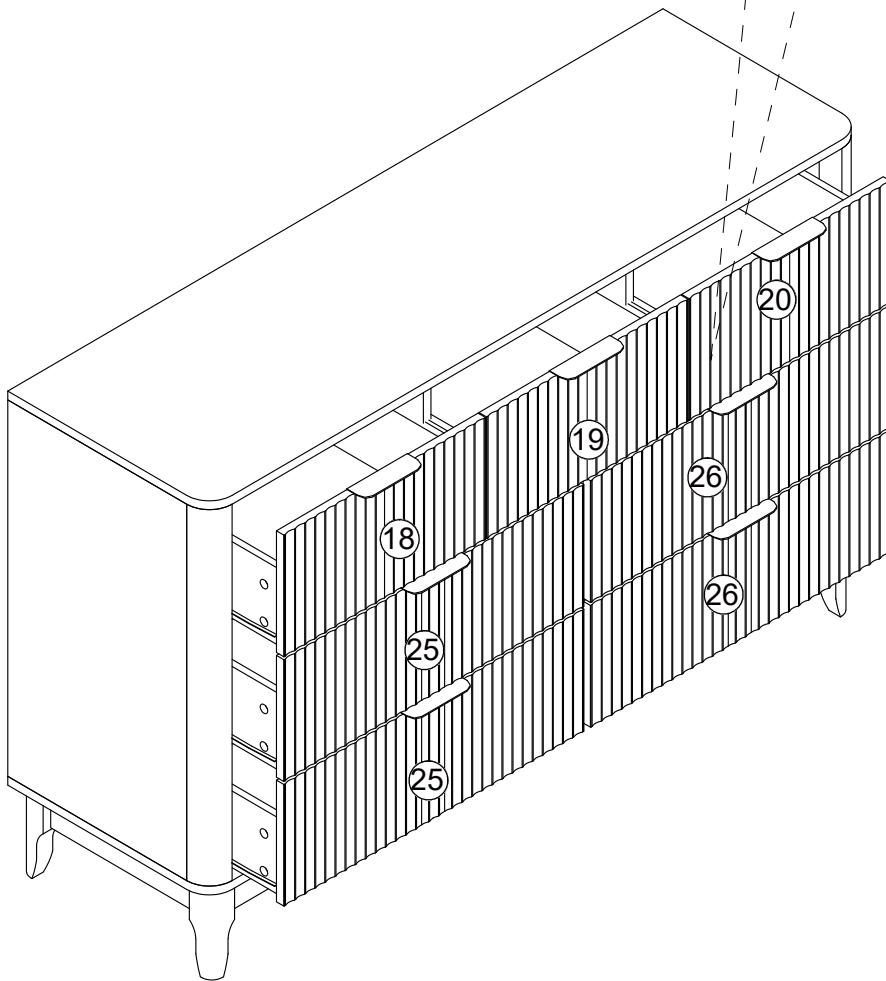
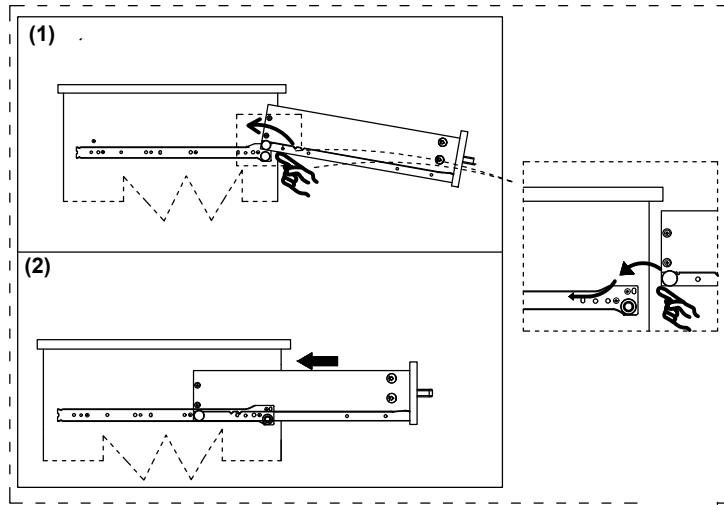

Slide the drawer in along the track inside the cabinet according to the details in the diagram (please follow the correct drawer number).

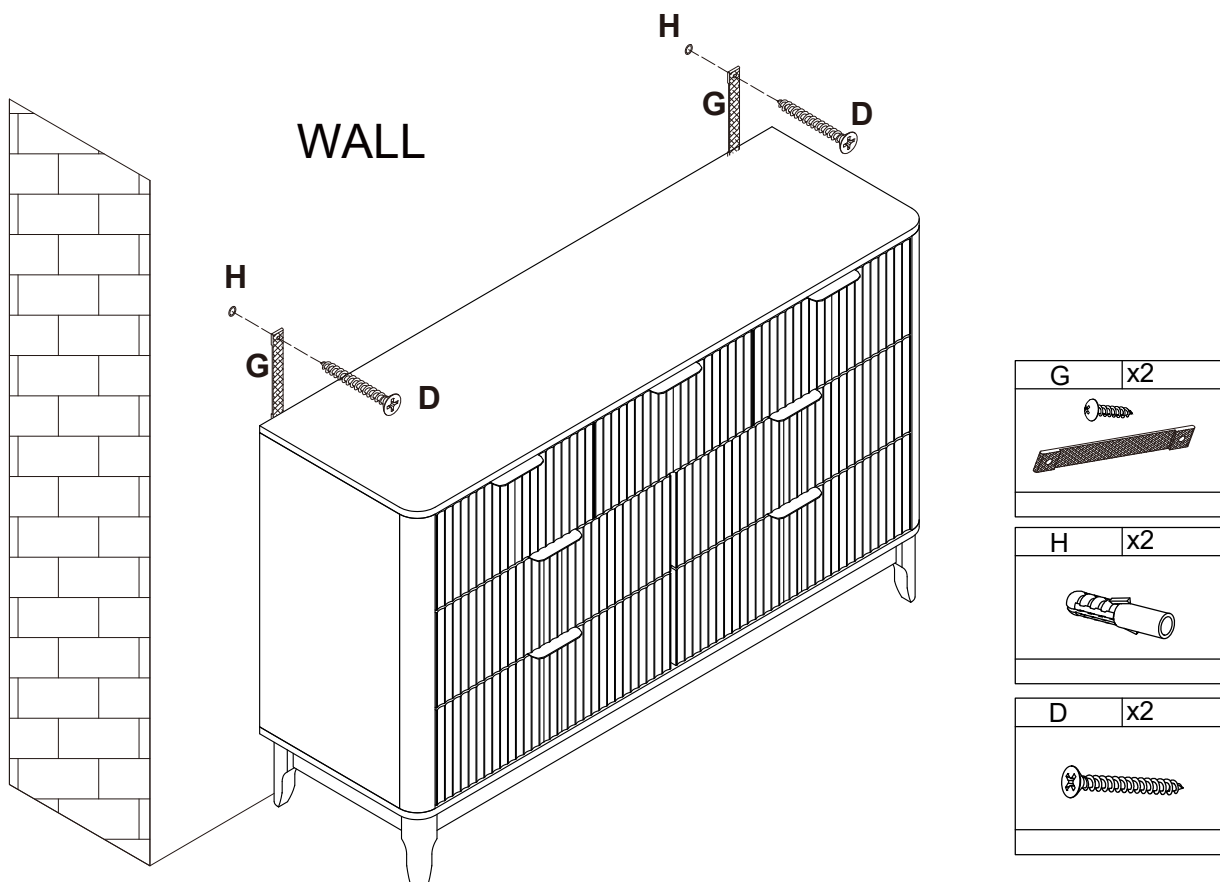
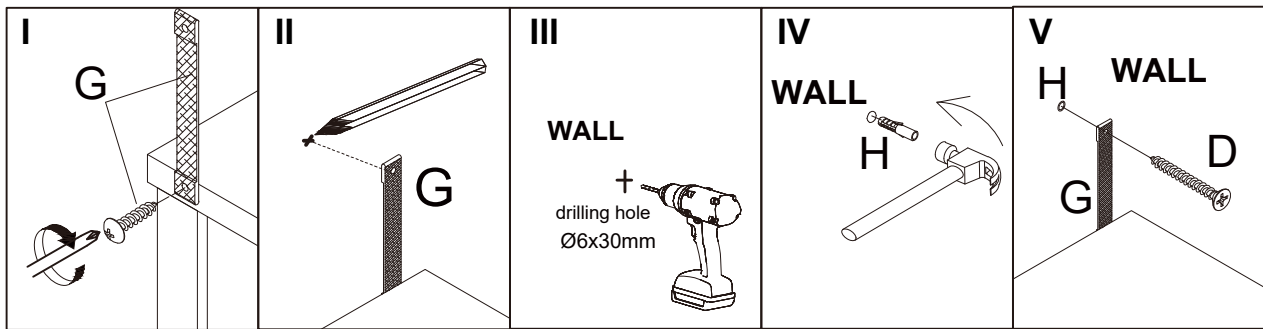

This step aims to fix the cabinet to the wall.

I: use the corresponding screws to tighten the anti-dumping ligament strip G (2 pcs) in the corresponding positions.

II: First, align the ligament G with the position on the wall where it is to be fixed and preset and mark the points.

III: Use an electric drill to drill holes at the marked positions on the wall. The size of the holes should be suitable for the screws and should not exceed the size.

IV: Then use a hammer to insert the screw cap H into the wall hole.

V: Use screw D to embed and fix the ligament G alignment nut H.

Thank You!

For Your Purchase

Dear Customer,

Thank you for your recent order.

Each customer enjoys a one-year warranty. Once the warranty is activated, we promise to provide you with a risk-free experience, please contact us to register and activate it.

Contact us before a refund/ return to open the fast track. We're online 24 hours a day.

Have a wonderful day!

Contact us to unlock benefits

- ✓ Activating the One-year Warranty
- ✓ Viewing the Installation Video
- ✓ Getting a \$5-\$15 Gift Card / Salt Lamp
- ✓ Joining the New Product Trial Program

Please kindly contact us in time if you need customer service.

 +1 7402568754

 service_April@163.com

Thanks again for your purchasing!