







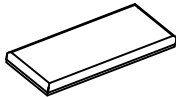

CARE AND MAINTENANCE

Wipe clean with a soft, dry cloth. Test the cleaning method on a hidden area before using them over the entire area.

NOTICE

- * Please make sure that you have all parts indicated before you begin assembly of this item.
- * This item should be assembled on a soft surface to prevent scratching the finished product during assembly.
- * This item may require periodic tightening.
- * Do not tighten bolts until completely assembled.

Part List and Hardware List

PIECE	DESCRIPTION	PICTURE	QUANTITY
A	Seat Cushion		1x
B	Left Side Frame		2x
C	Right Side Frame		2x
D	Long Connecting Bar		2x
E	Short Connecting Bar		2x
H1	Allen Bolt	 1/4"x 5/8"	16x
H2	Allen Bolt	 1/4"x 1-1/2"	4x
H3	Allen Key	 M4	1x

Product Dimensions: 46"Wx18"Dx18"H

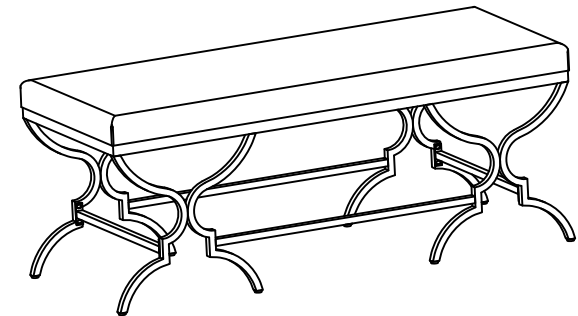

Weight capacity : 550 lbs
WARNING:DO NOT STAND ON THE BENCH

PREPARATION

Before beginning assembly of product, make sure all parts are present. Compare parts with package contents list and hardware contents list. If any part is missing or damaged, do not attempt to assemble the product.

Estimated Assembly Time: 20 minutes.

Tools Required for Assembly (included): Allen Key

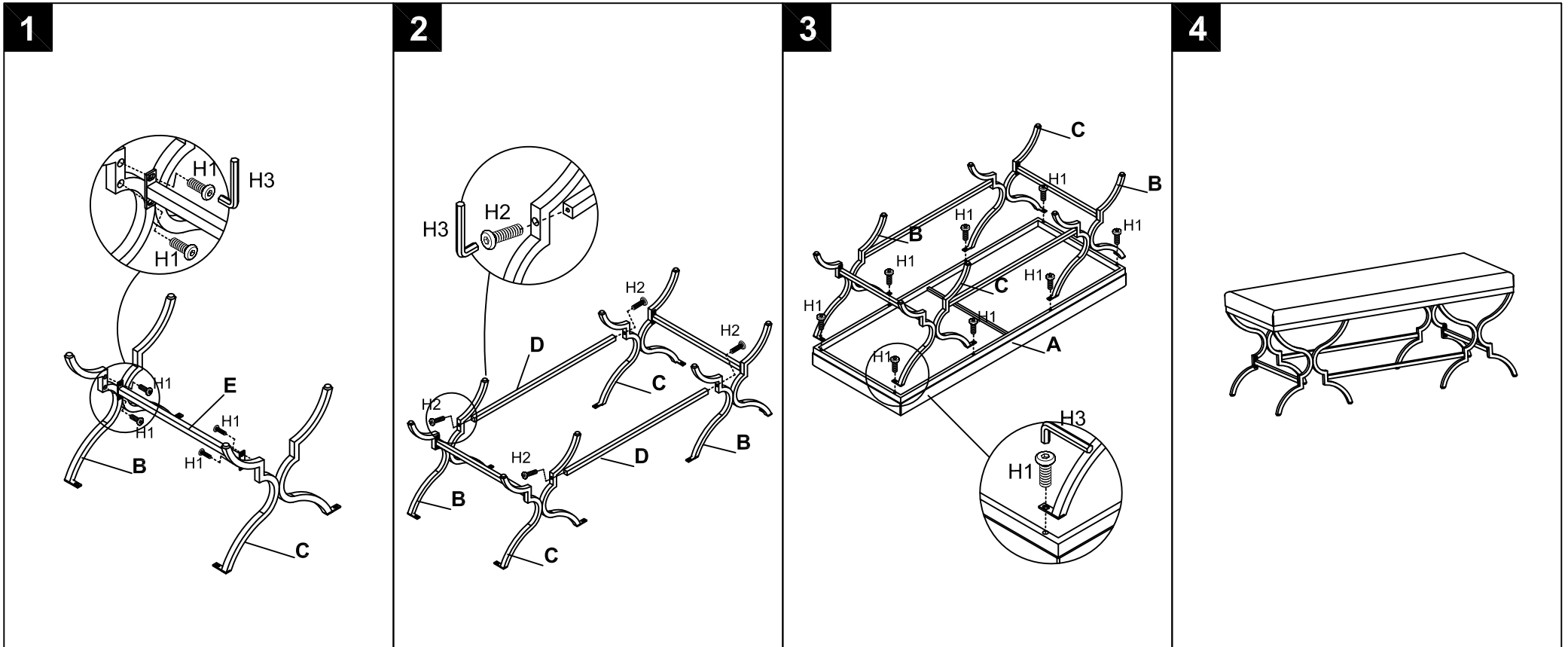

Step 1

** insure all screw holes on side frame (B&C) are facing inward.**
Attach the Short Connecting Bar (E) on L/R Side Frame (B/C). Insert bolts (H1) into screw holes, Use Allen key (H3) to tighten. reference image above. (Repeat the same process for the second side frame)

Step 2

** insure all screw holes on side frame (B&C) are facing inward.**
Attach 2*Long Connecting Bar (D) on assembled L/R Side Frame (B/C), Insert bolts (H2) into screw holes, Use Allen key (H3) to tighten. reference image above.

Step 3

Attach the assembled metal base to the underneath of Seat Cushion (A), Align all screw holes on seat cushion (A) with the threads on the metal base, Inset Allen bolts (H1) into the holes and tighten with Allen key (H3). reference image above.

Step 4

Stand upright up the assembled product, assembly is completed.