

CAL KING PLATFORM BED ASSEMBLY INSTRUCTIONS

PARTS AND HARDWARE PACKAGING DETAIL

BOX #1
A. HEADBOARD 1 PC

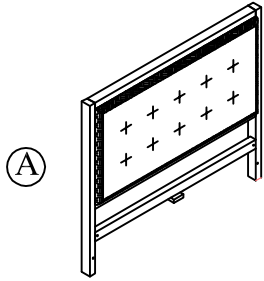

BOX #3
C. SIDE RAIL 2 PCS
D. SUPPORT SLAT 1 PC
E. SUPPORT LEG 2 PC

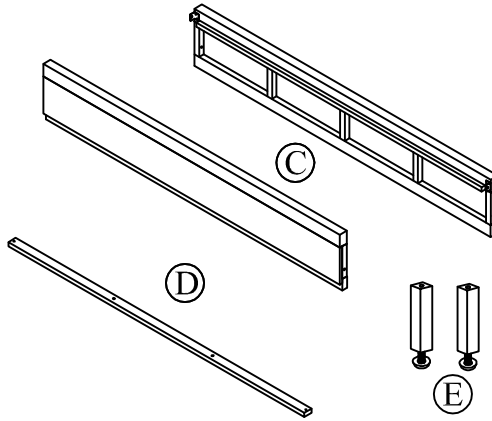

BOX #4
F. SLAT ROLL (13 SLATS) 1 PC

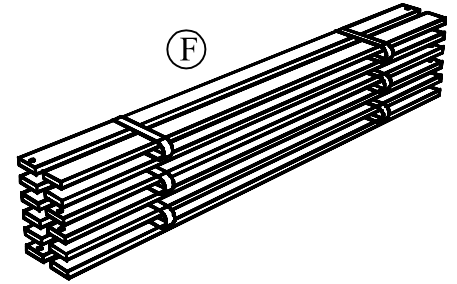

BOX #2
B. FOOTBOARD 1 PC

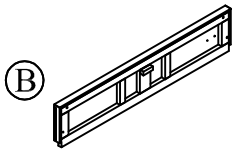

OXFORD CAL KING PLATFORM BED ASSEMBLED

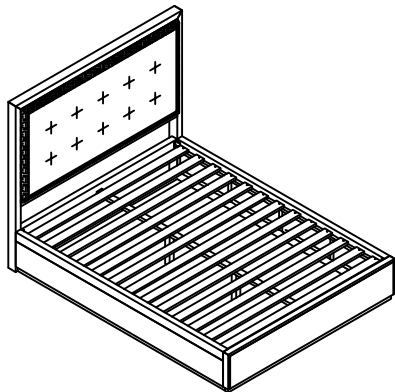

HARDWARE PACKED IN BOX #3

1. ALLEN BOLT (M8X50) 4PCS

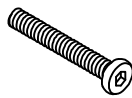

2. FLAT WASHER (M8) 8PCS



3. ALLEN BOLT (M8X20) 4PCS



4. ALLEN BOLT (M6X50) 2PCS



5. WOOD SCREW (4X30) 31PCS



6. ALLEN KEY 1PC

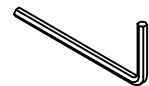

STEP 1

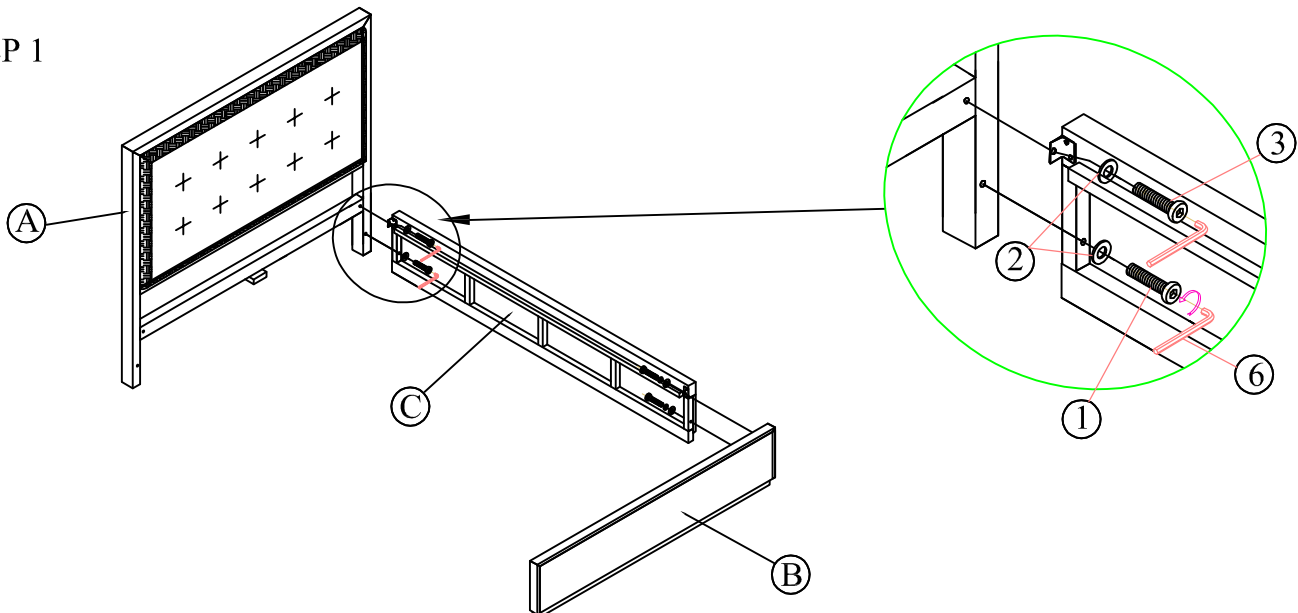

CAL KING PLATFORM BED ASSEMBLY INSTRUCTIONS

PARTS AND HARDWARE PACKAGING DETAIL

STEP 2

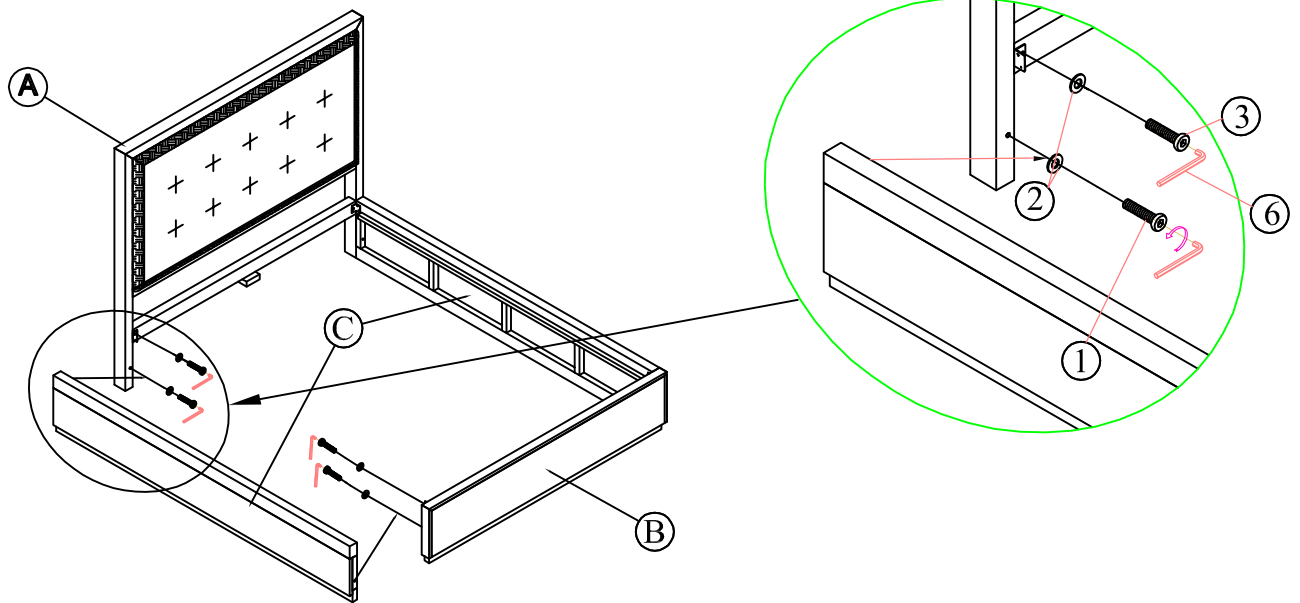

STEP 3

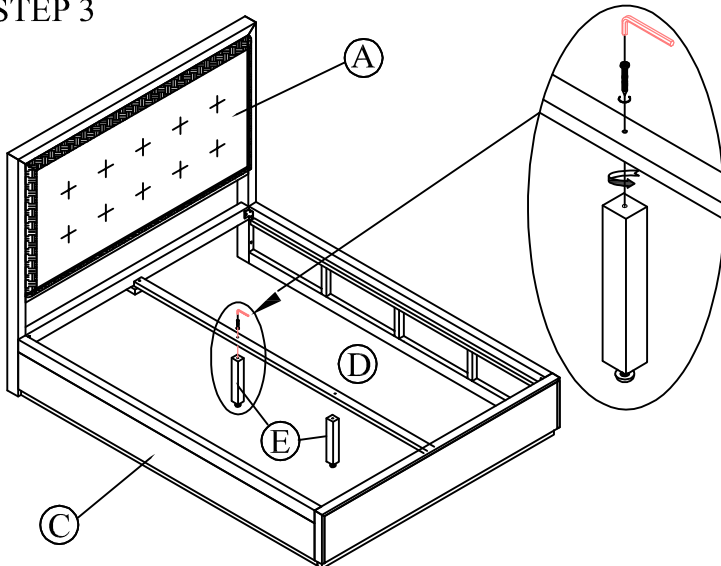

STEP 4

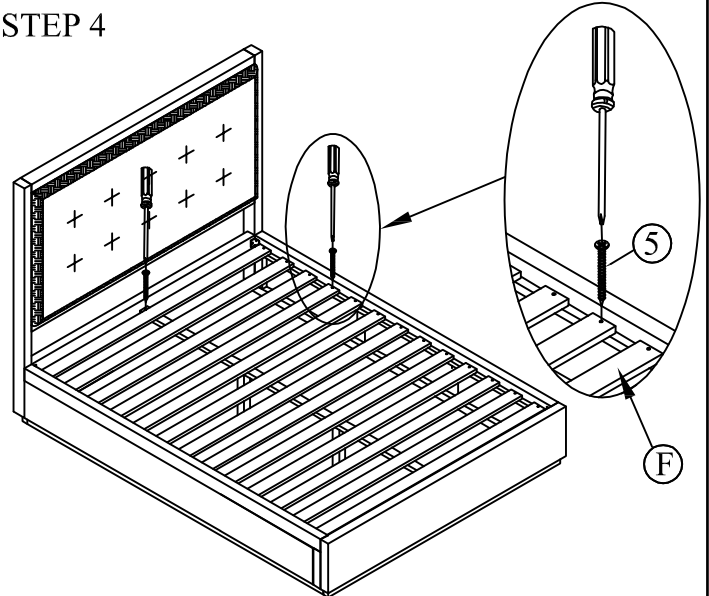

INSTRUCTIONS FOR ADJUSTING LEVELER

POSITION THE BED IN YOUR SPACE AND LOCATE THE LEVELER UNDER EACH SUPPORT LEG. TURN THE LEVELER COUNTER-CLOCKWISE TO EXTEND THE LEVELER AND CLOCKWISE TO RETRACT IT.

ADJUST EACH LEVELER UNTIL EACH SUPPORT LEG IS APPLY EQUAL, UPWARD PRESSURE ON THE SUPPORT SLAT.

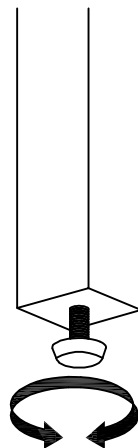

MAINTENANCE INSTRUCTIONS:

REMOVE YOUR MATTRESS, AND BOX SPRING IF APPLICABLE, BEFORE MOVING YOUR BED.

LIFT YOUR BED WHEN MOVING IT; DRAGGING CAN DAMAGE THE SUPPORTS.

RE-ADJUST THE LEVELERS AFTER MOVING YOUR BED.