

Assembly Instructions

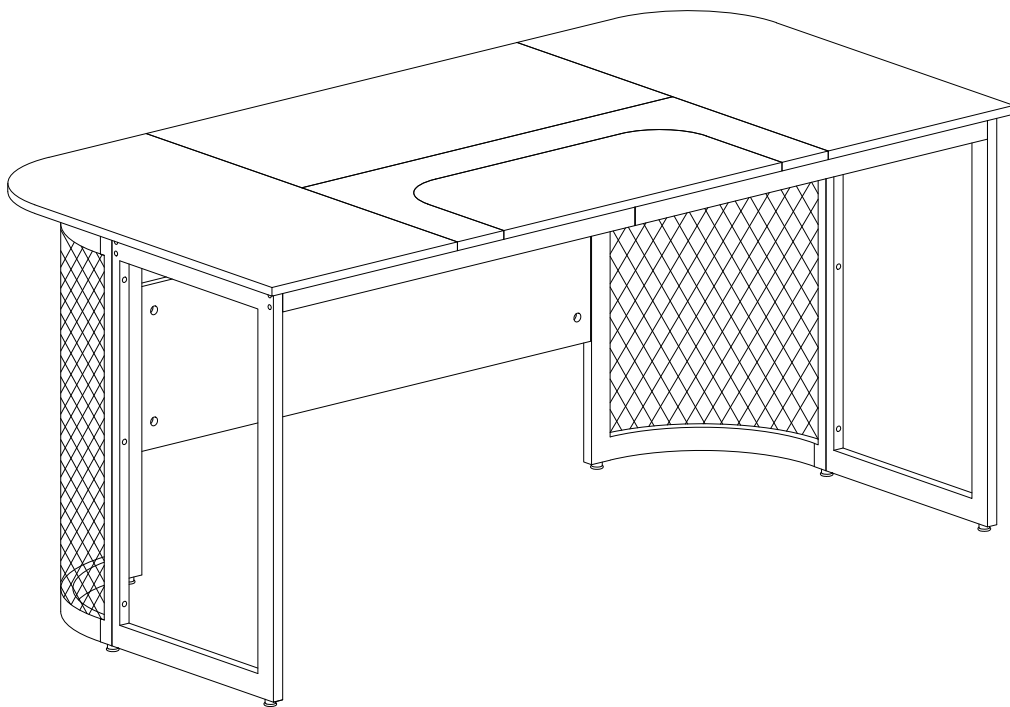

Executive Desk

Warm Tips

1. Carefully read these instructions and keep them for future reference.
2. Check the parts list and confirm everything's there before starting assembly.
3. When assembling, put all parts on a soft, smooth surface like a carpet to avoid scratches.
4. Don't fully tighten screws until all parts are confirmed in place to avoid misalignment.

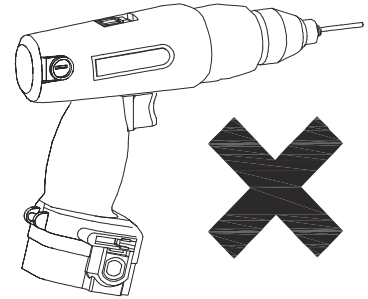
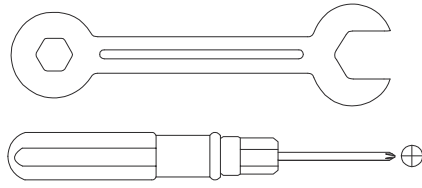
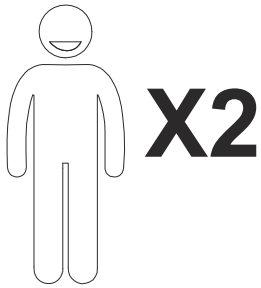

We recommend using hand tools for assembly.

If an electric screwdriver is used, reduce power and torque to avoid damage to the product.

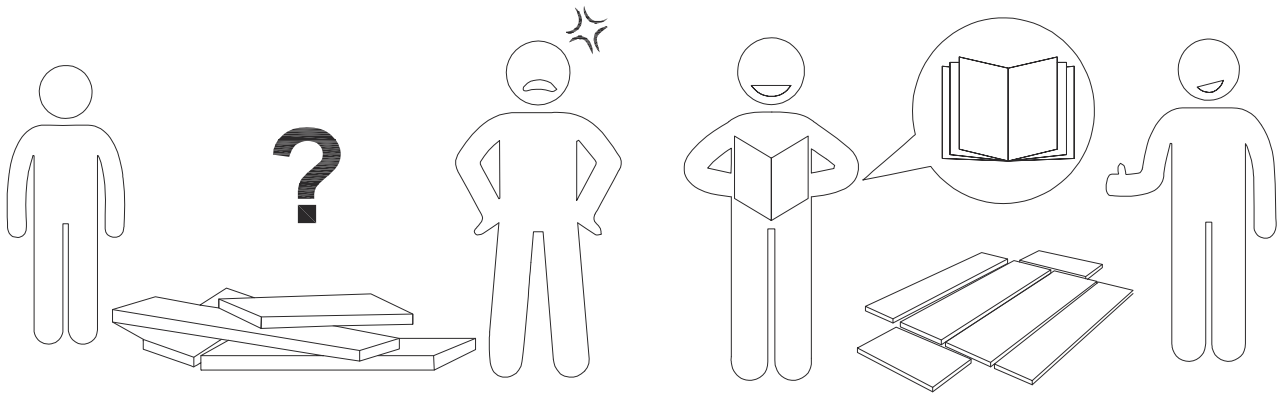

AVOID SCRATCHES

In order to avoid scratching, this furniture should be assembled on a soft surface, such as a rug.

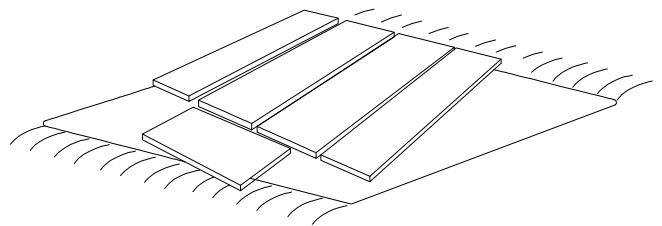
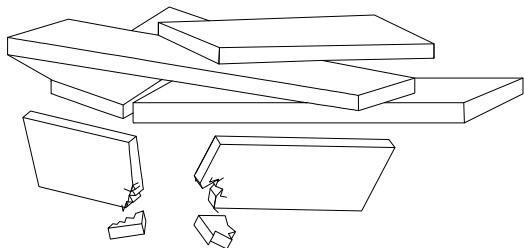

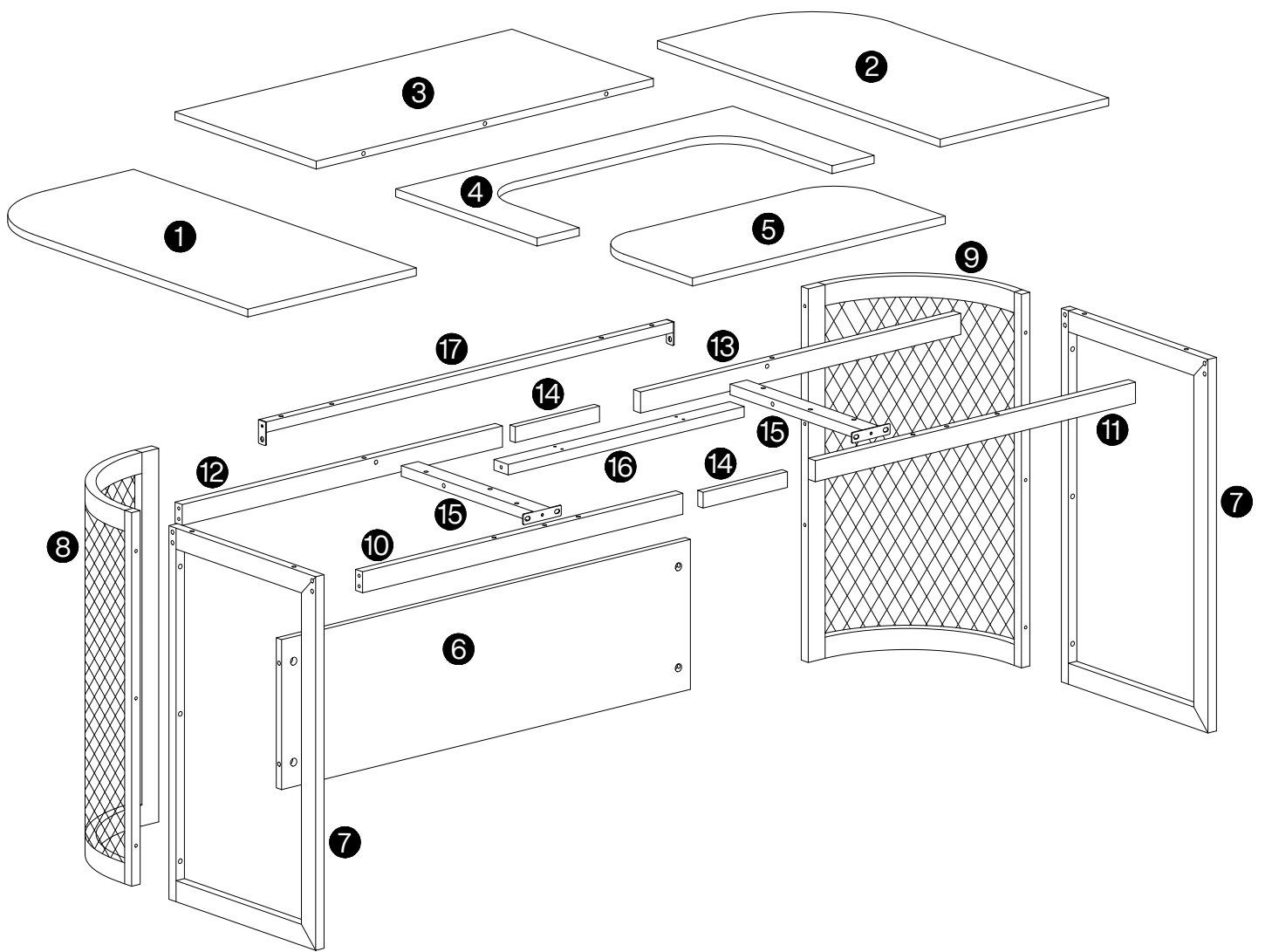

⚠ Caution

Make sure all parts are included. Most board parts are labeled or stamped on the raw edge.

Parts List

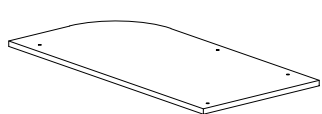

1 1pc

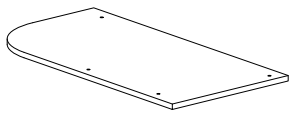

2 1pc

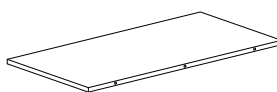

3 1pc

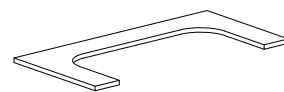

4 1pc

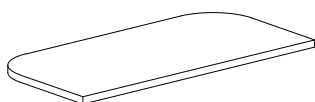

5 1pc

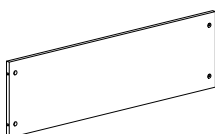

6 1pc

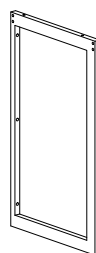

7 2 pcs

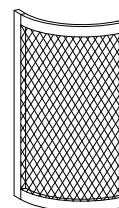

8 1pc

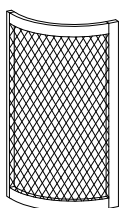

9 1pc

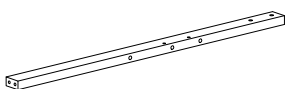

10 1pc

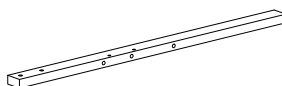

11 1pc

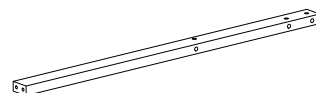

12 1pc

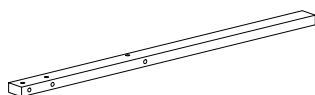

13 1pc

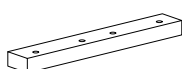

14 2 pcs

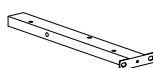

15 2 pcs

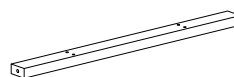







16 1pc

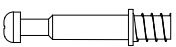

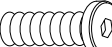
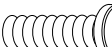
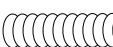

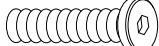
17 1pc

Hardware List

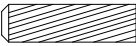
A	X4+1	B	X4+1	C	X22+1	D	X20+1	E	X10+1	F	X12+1
											
Ø6X35 mm		Ø15X12 mm		M6X12 mm		M6X30 mm		M6X40 mm		M6X50 mm	

G	X2+1	H	X1	I	X6	J	X1	K	X3+1
									
M6X60 mm		M4X55 mm		M6XØ20 mm		Ø20 mm		Ø8X30 mm	

1

screw down 

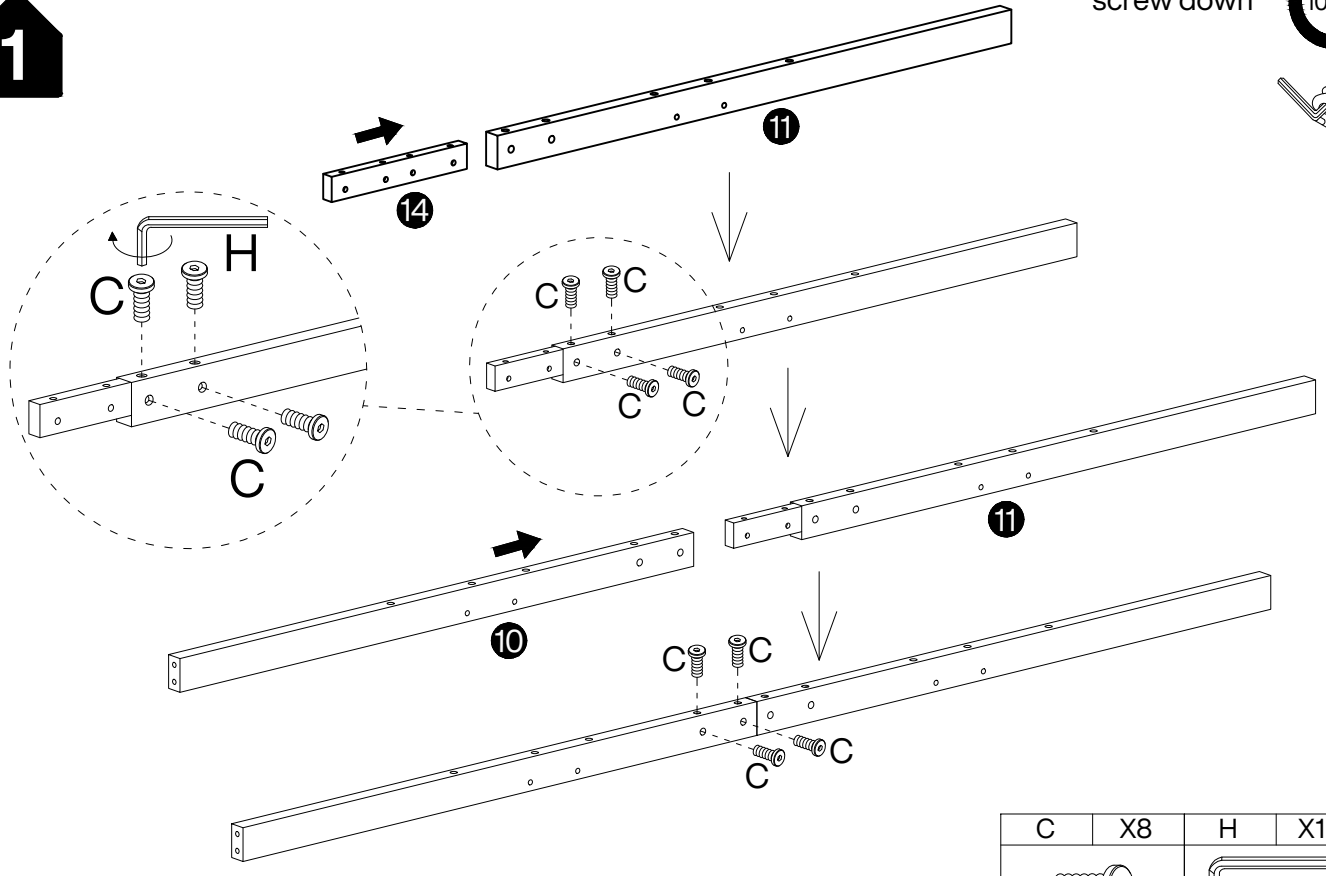

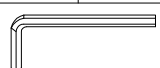

C	X8	H	X1
			
M6X12 mm		M4X55 mm	

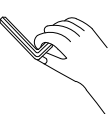
2

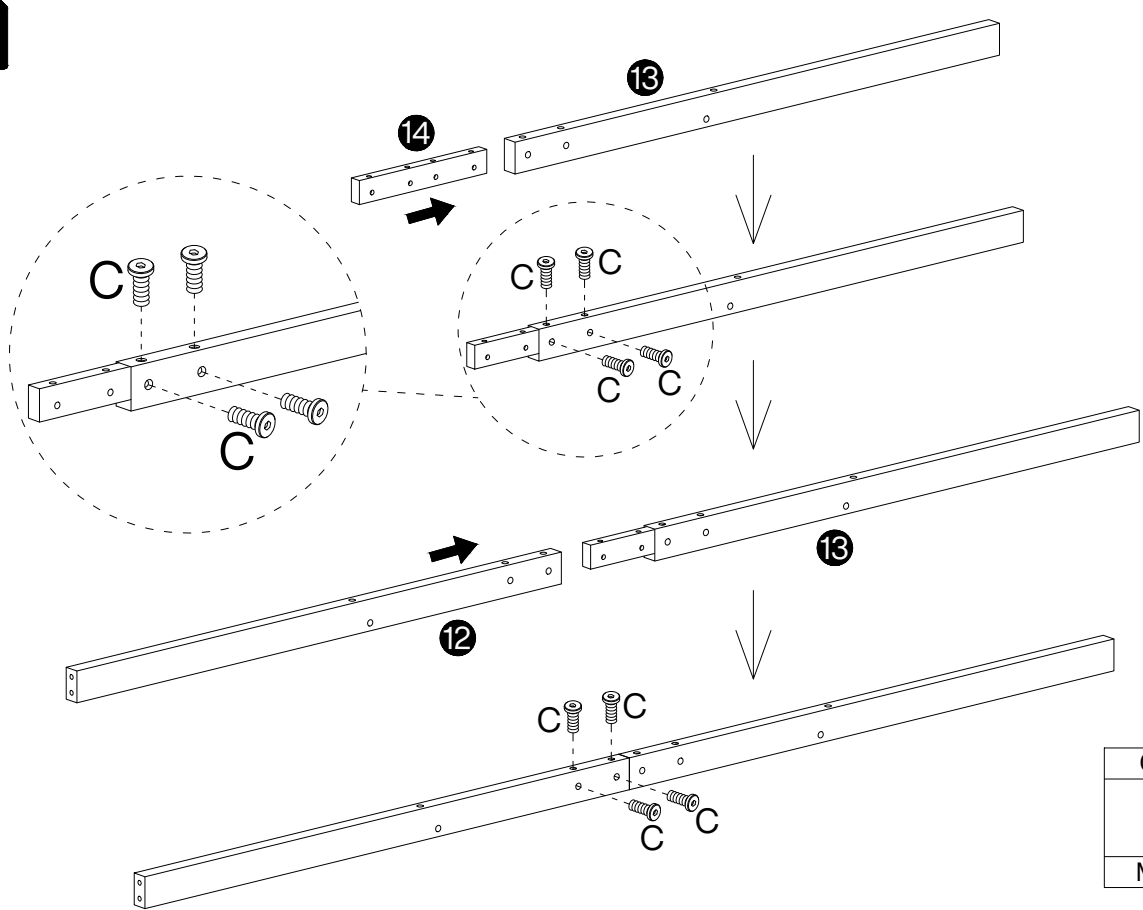
screw down 



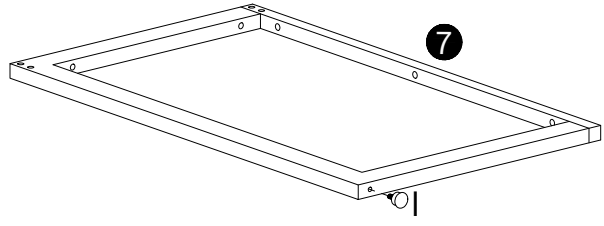

C	X8
	
M6X12 mm	

3

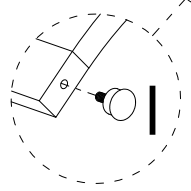
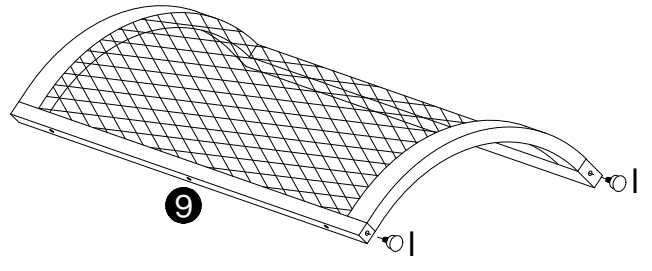
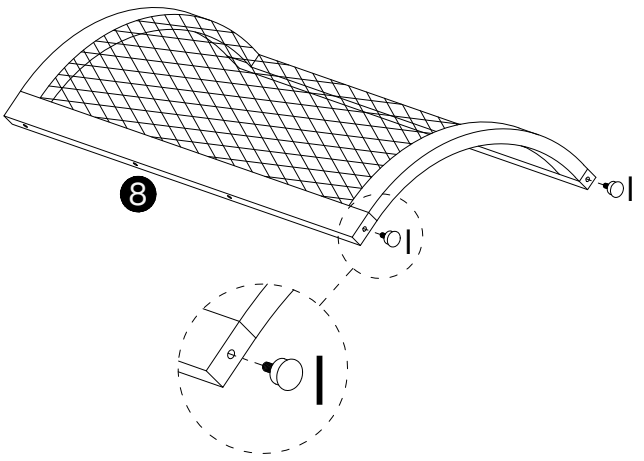

X2



I	X6
	
M6XØ20 mm	

4

pre-drill 70%

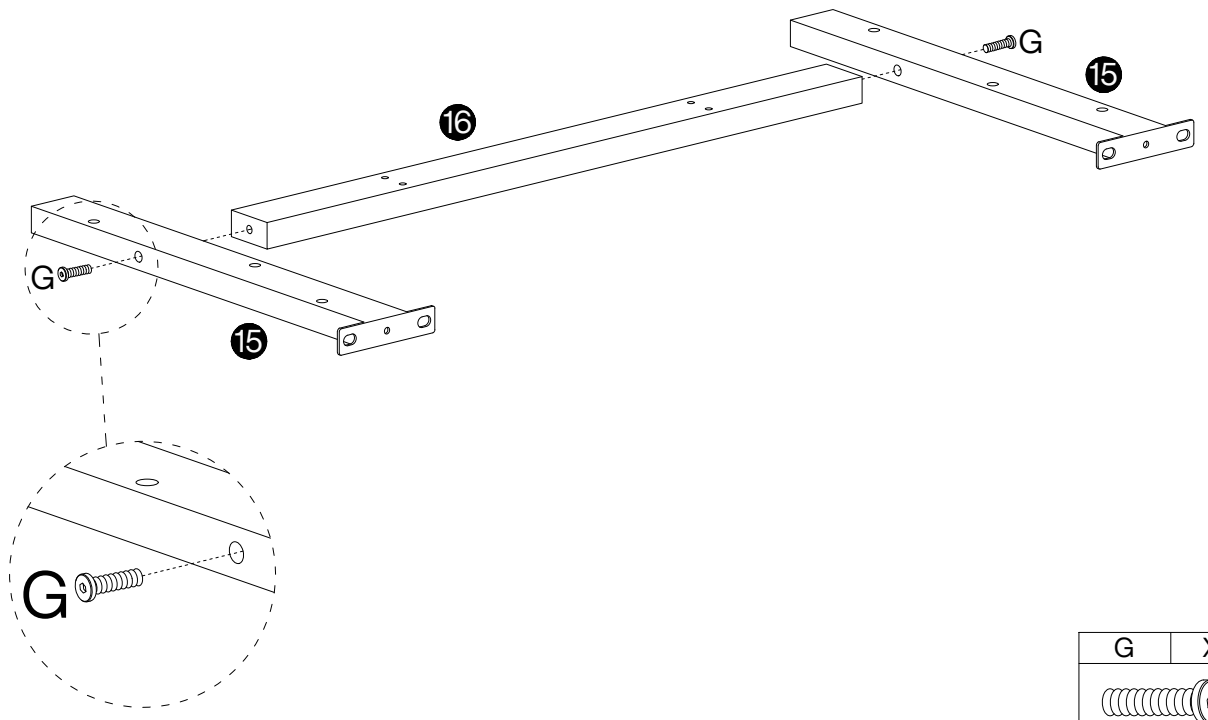

G	X2
	
M6X60 mm	

5

pre-drill 70%

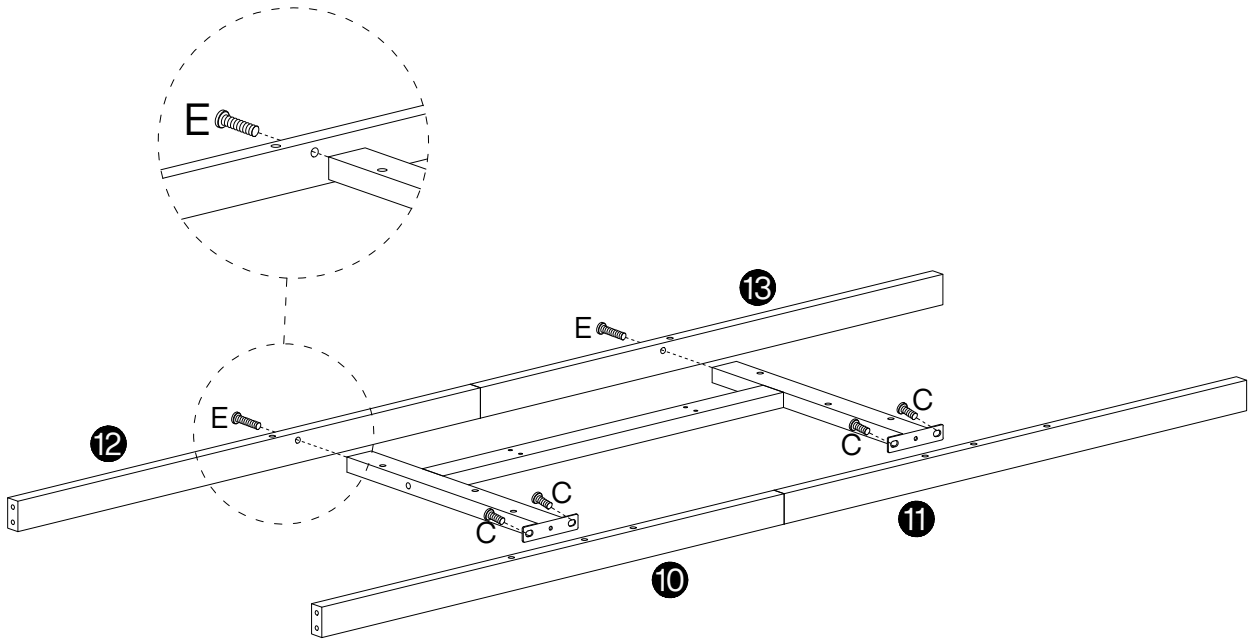

C	X4	E	X2
M6X12 mm		M6X40 mm	

6

pre-drill 70%

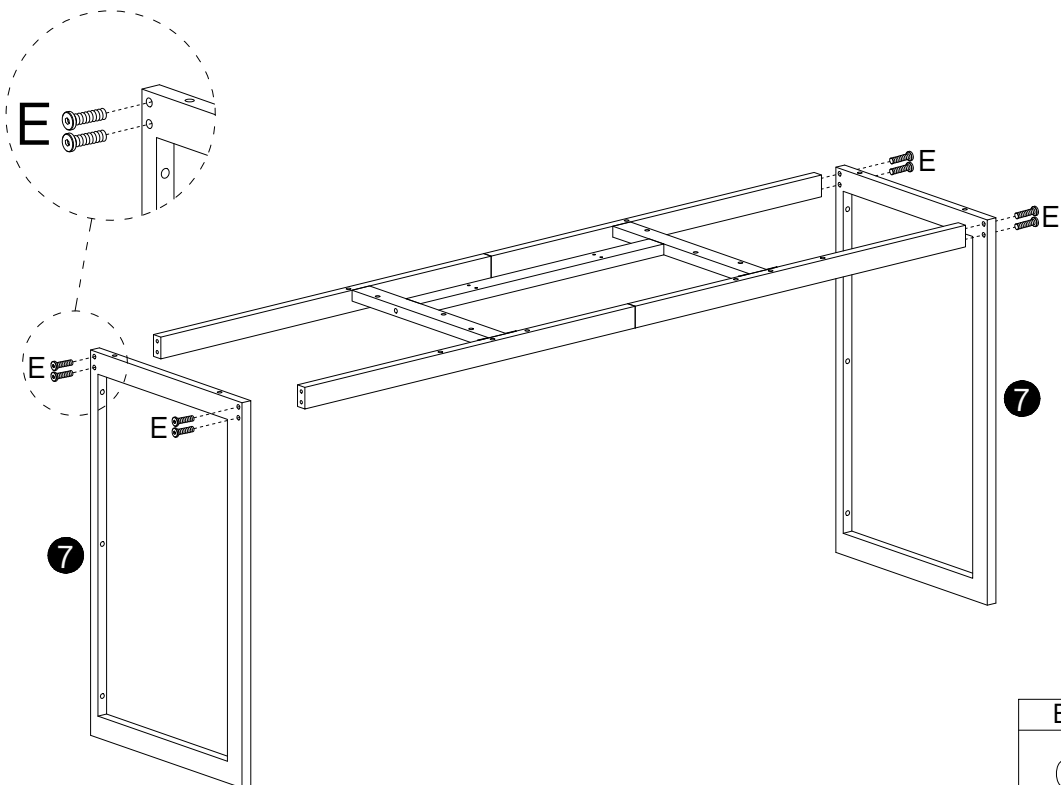

E	X8
M6X40 mm	

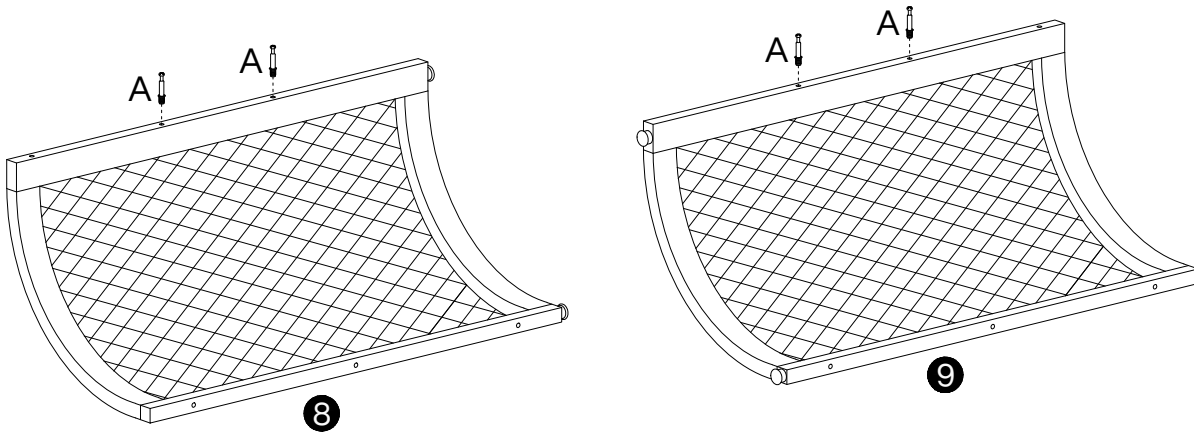
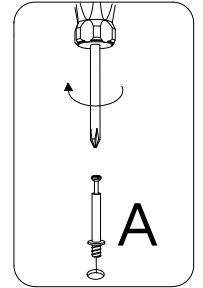

7

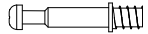

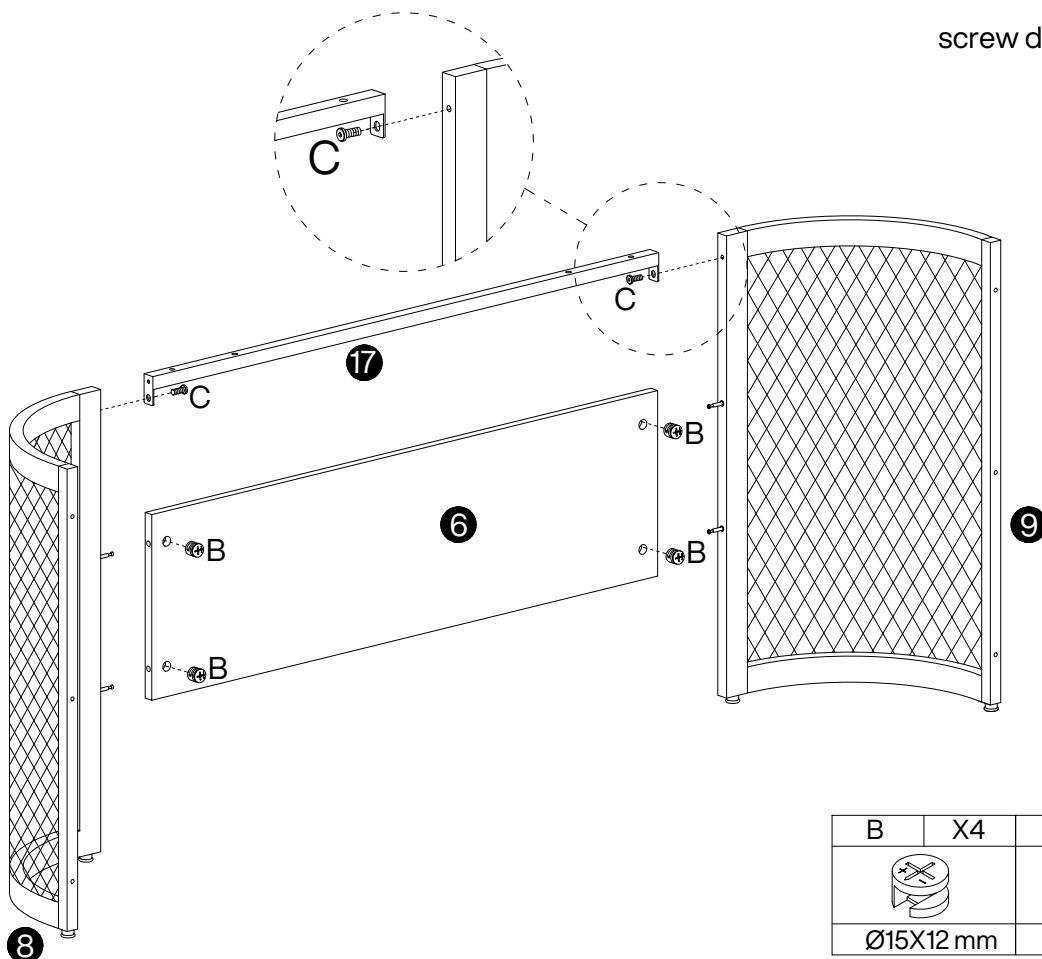
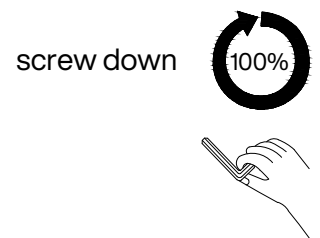

A	X4
	
Ø6X35 mm	

8



B	X4	C	X2
			
Ø15X12 mm		M6X12 mm	

9

pre-drill 70% 

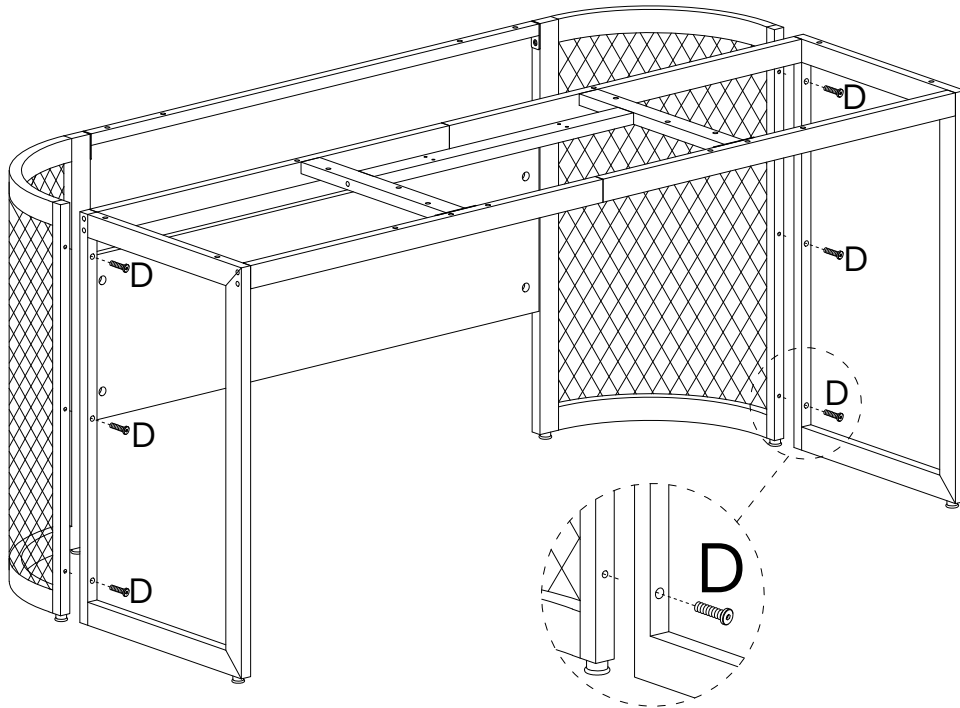

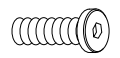
D	X6
	
M6X30 mm	

10

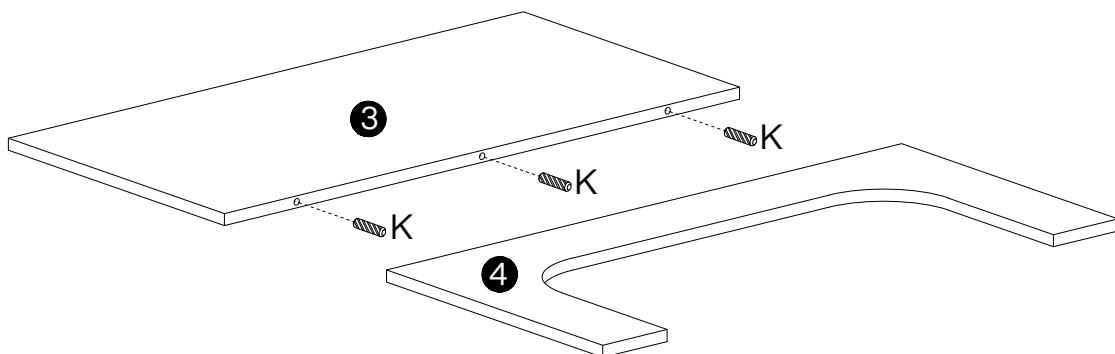



K	X3
	
Ø8X30 mm	

11

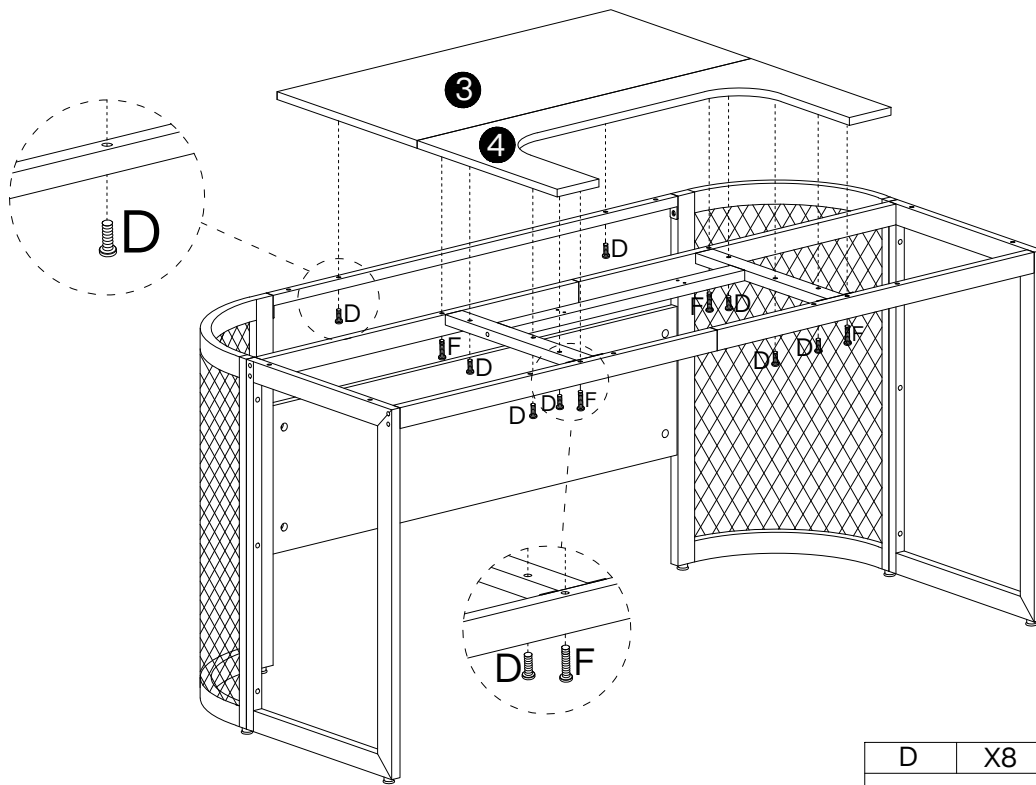
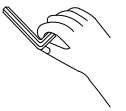
screw down 





D	X8	F	X4
			
M6X30 mm		M6X50 mm	

12

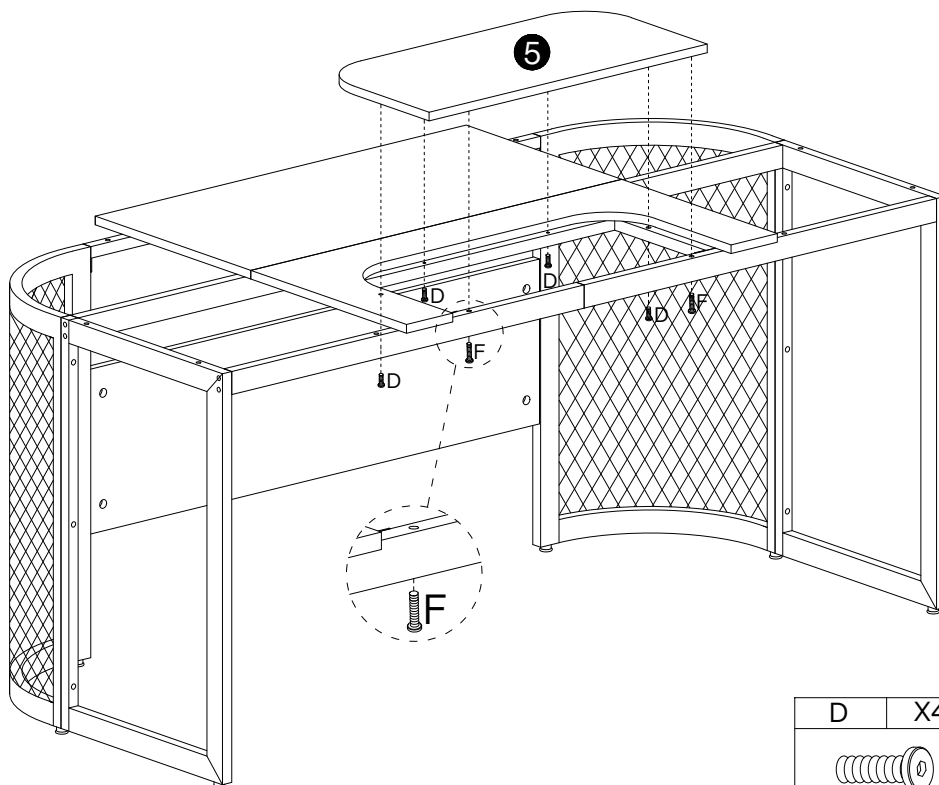
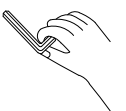
screw down 



D	X4	F	X2
			
M6X30 mm		M6X50 mm	

Thank you for your support!

