

Installation & Assembly

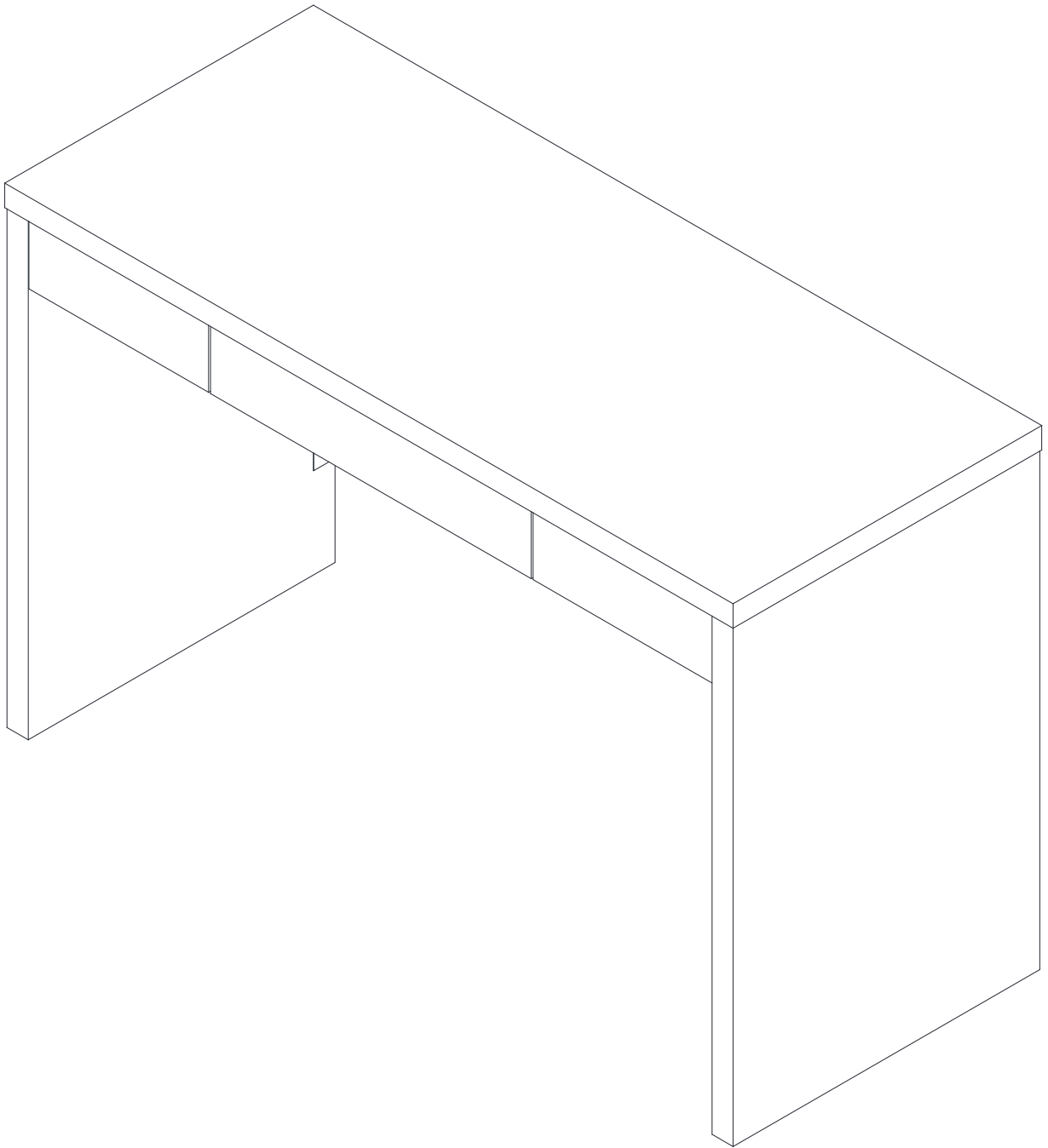

Assembly Instructions

Before beginning the assembly process, please read and save these instructions for reference. Following these guidelines will ensure a smooth and successful assembly of your product.

1. Part Identification:

Carefully separate and identify all the parts included in your package. Confirm that you have all the components listed in the instruction manual. This step will help you avoid any missing or misplaced parts during assembly.

2. Work Surface:

To prevent any scratches or damage to the product, assemble it on a soft mat or a similar protective surface. This will provide a cushioned area for the components and protect the surfaces from unwanted marks.

3. Step-by-Step Assembly:

Follow the assembly instructions provided, proceeding one step at a time. Take care to understand each step properly before proceeding to the next one. This sequential approach ensures that the assembly is done correctly and minimizes the chance of errors.

4. Proper Screw Seating:

When attaching screws and nuts, it is essential not to fully tighten them until all screws are correctly seated. By partially tightening each screw and nut initially, you can ensure that they are aligned properly and fit securely before final tightening.







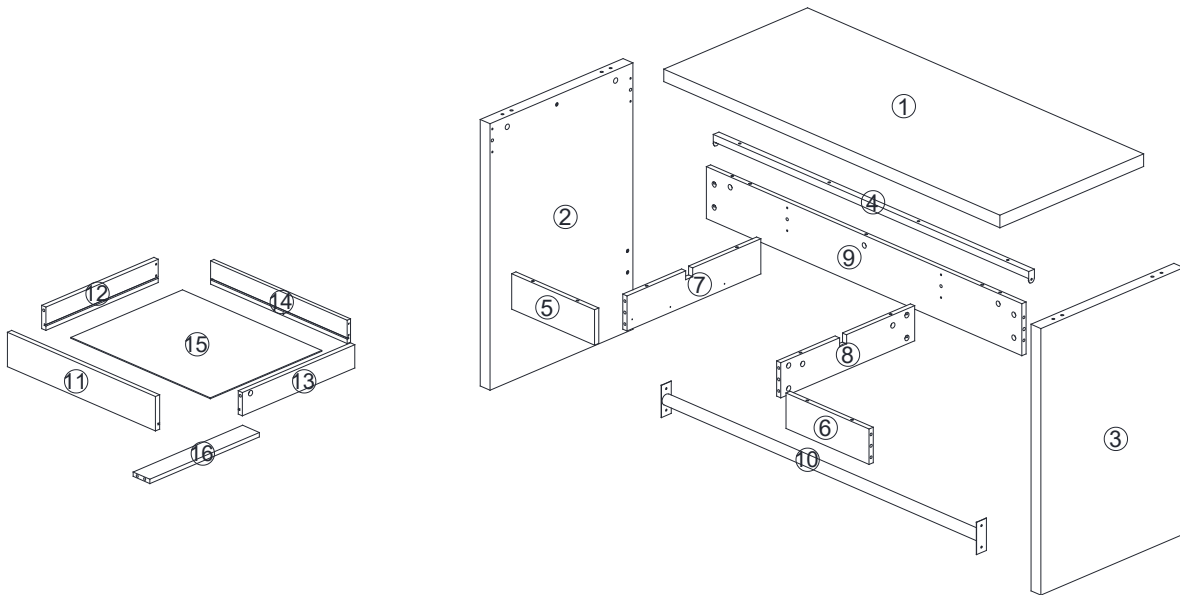





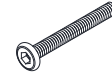

5. Avoid Over-Tightening:

While each screw and nut should be tightened correctly, it is crucial not to over-tighten them. Over-tightening can cause damage to the product or compromise its structural integrity. Use the appropriate amount of force to secure the components without excessive tightening.

Parts List



Hardware List

A x35  Ø6x35	B x35  Ø15x10	C x14  Ø8x30	D x6  Ø8xM4x35	E x12  Ø6.5xM3x12	F x6  M6x12	G x4  M6x30
H x1  M4	I x2  Ø6x30	J x4 	CL x1  400mm	CR x1  400mm	DL x1  400mm	DR x1  400mm

Code	Description	Quantity
A	Cam bolt	35+2
B	Cam lock	35+2
C	Wooden dowel	14+2
D	M4x35MM Screw	6+1
E	M3x12MM Screw	12+2
F	M6x12MM bolt	6+1
G	M6x30MM bolt	4+1

Code	Description	Quantity
H	Wrench	1
I	Wooden dowel	2
J	Adjusting the footrest	4
CL	400mm Drawer runner set	1
CR	400mm Drawer runner set	1
DL	400mm Drawer runner set	1
DR	400mm Drawer runner set	1

Step 1

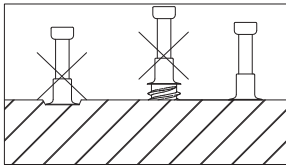
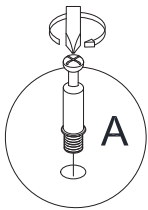
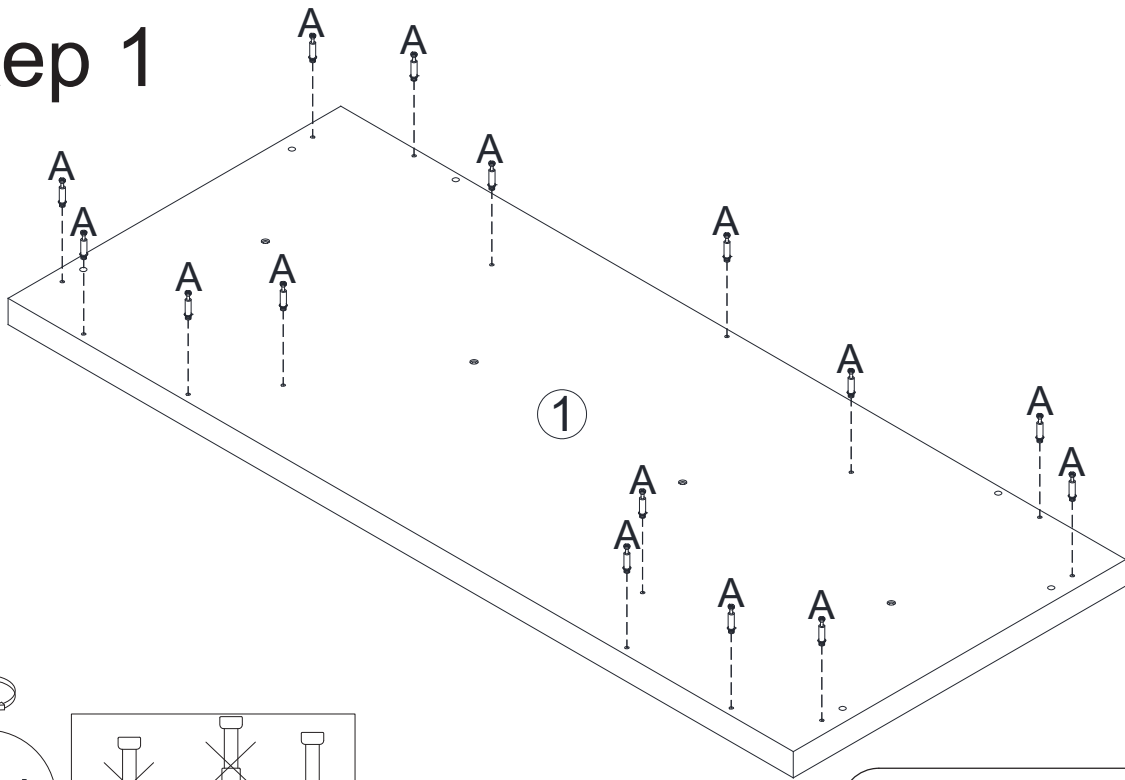

A



X 15

Step 2

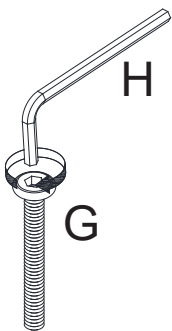
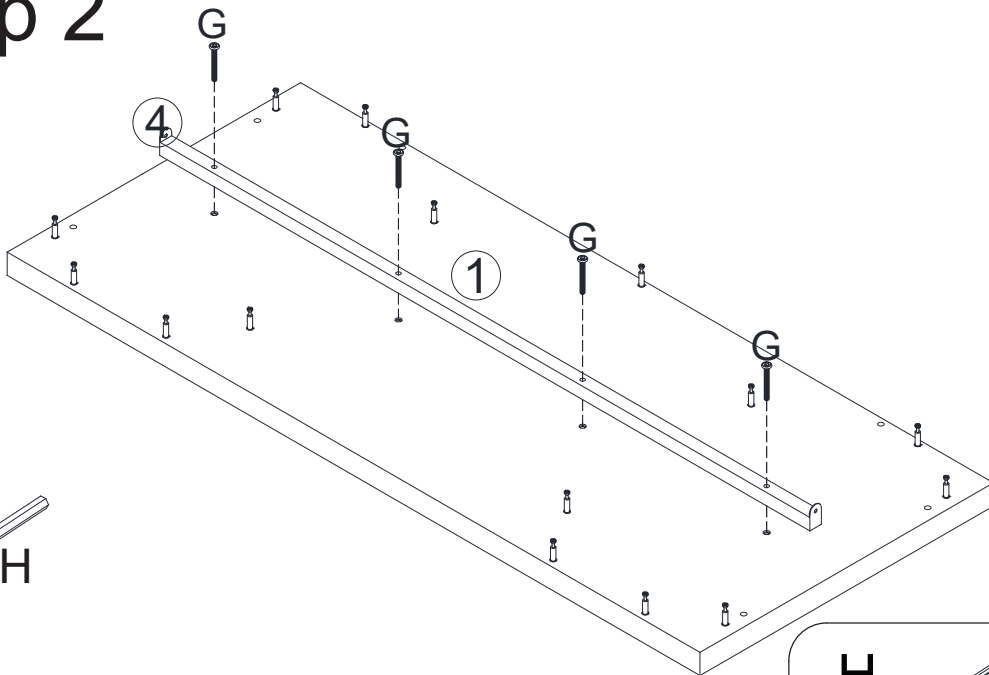

H



X 1

G

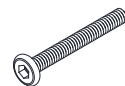

X 4

Step 3

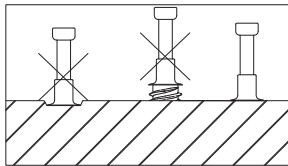
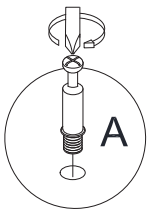
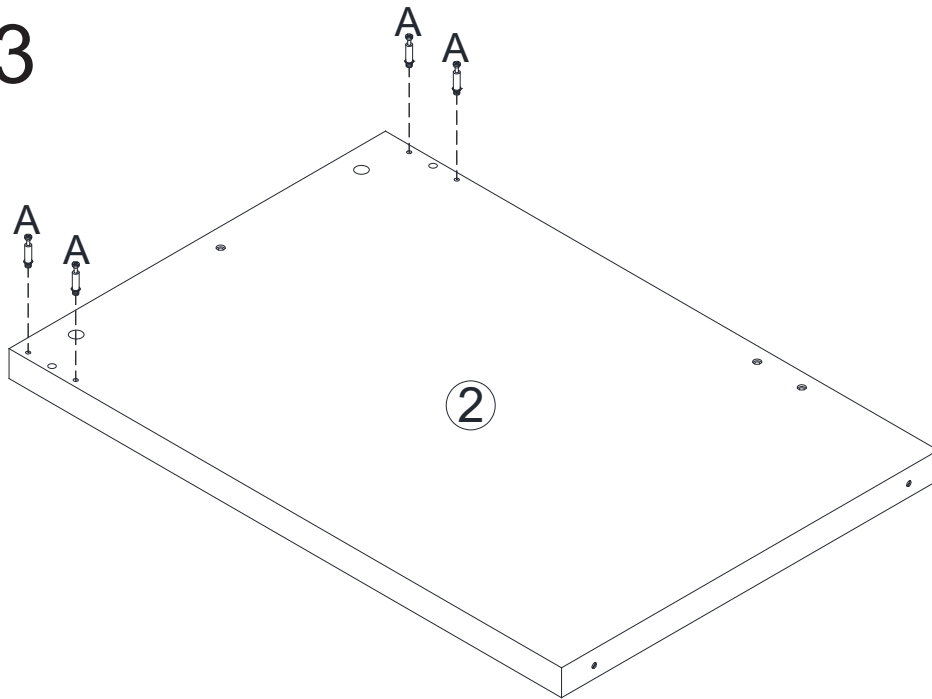

A

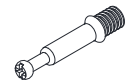

X 4

Step 4

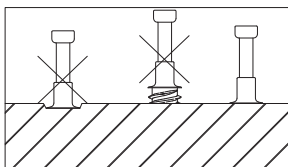
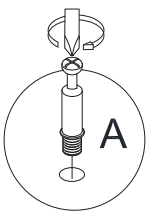
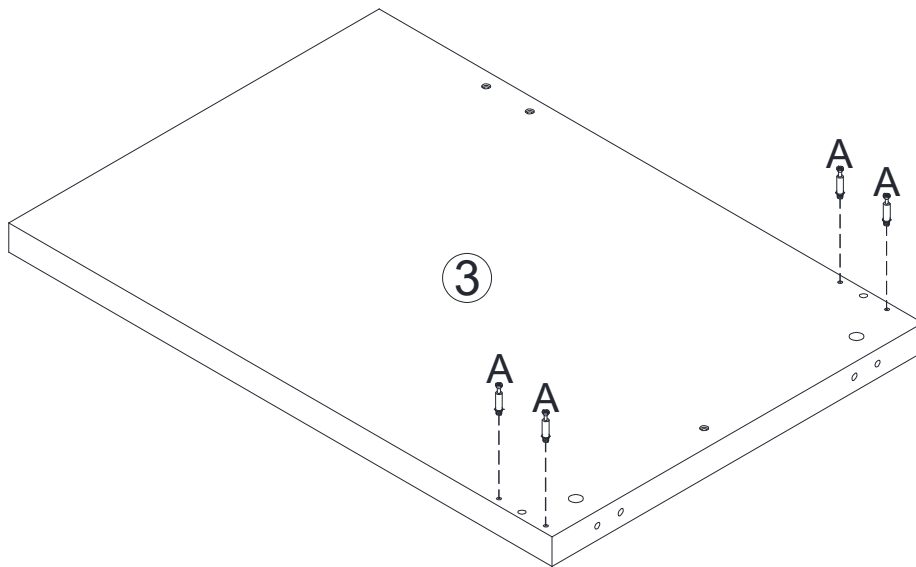

A

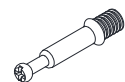

X 4

Step 5

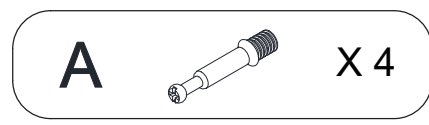
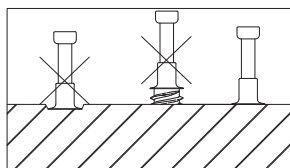
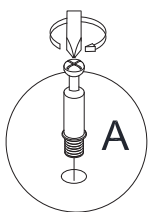
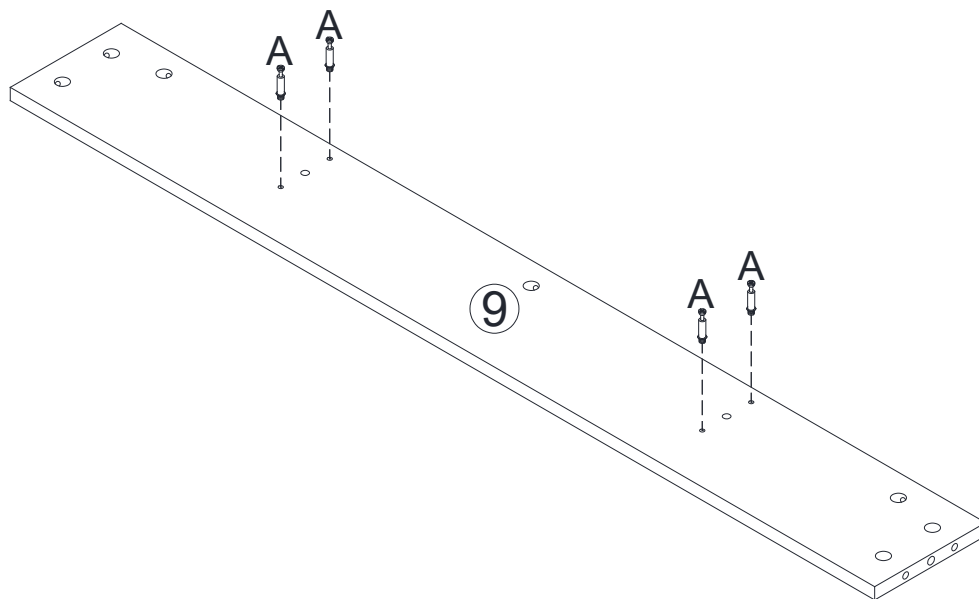

Step 6

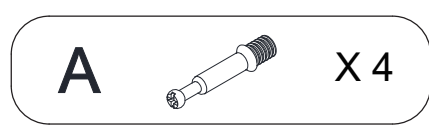
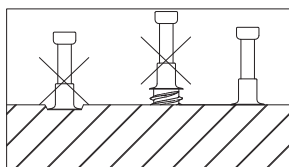
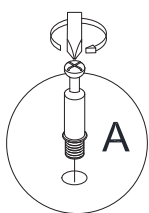
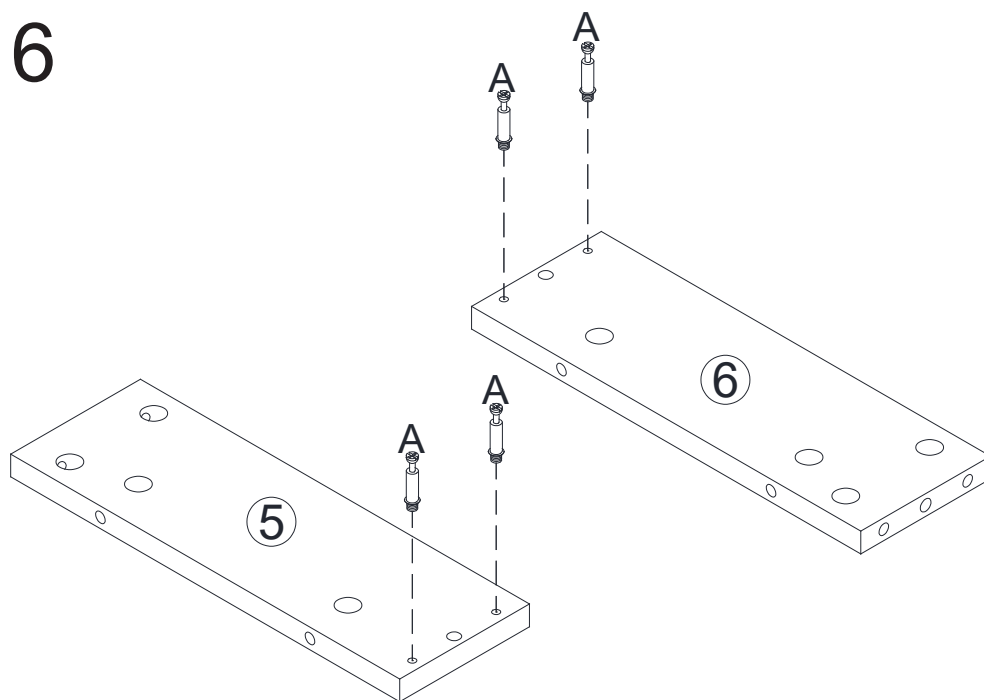

Step 7

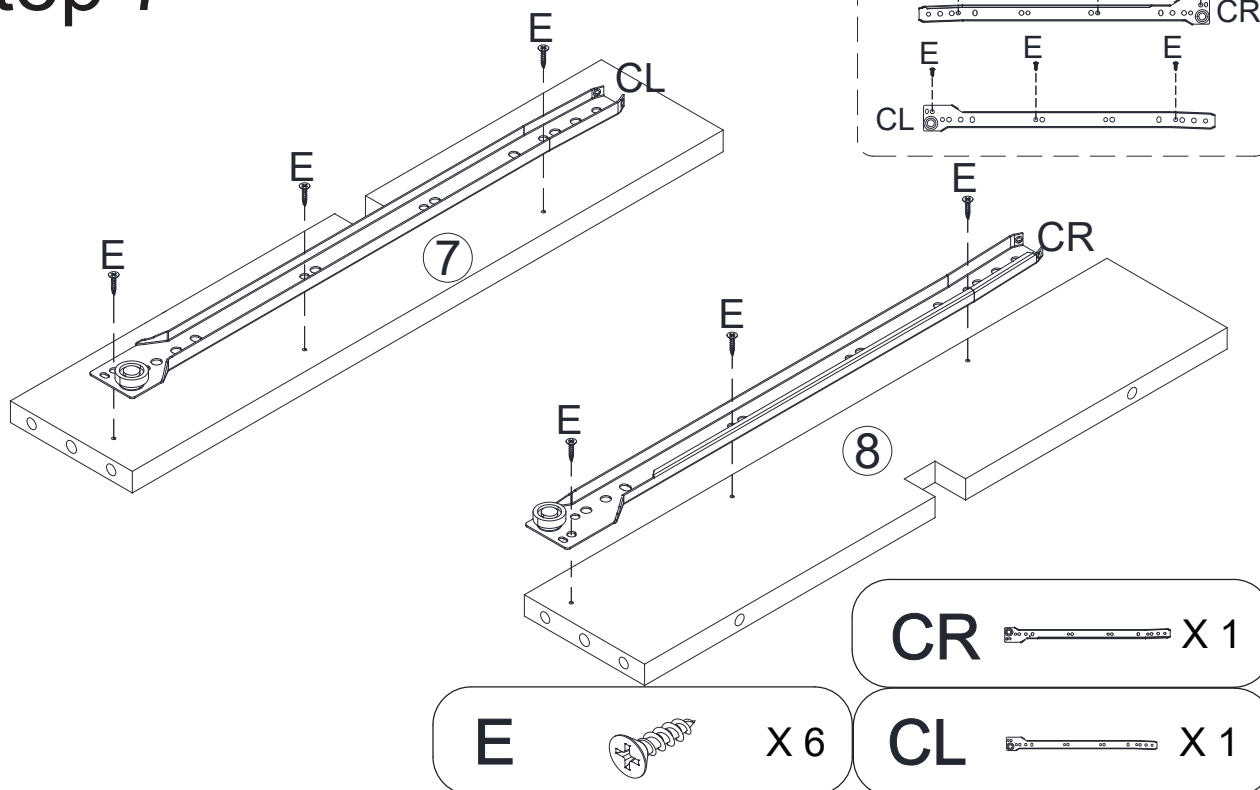

Step 8

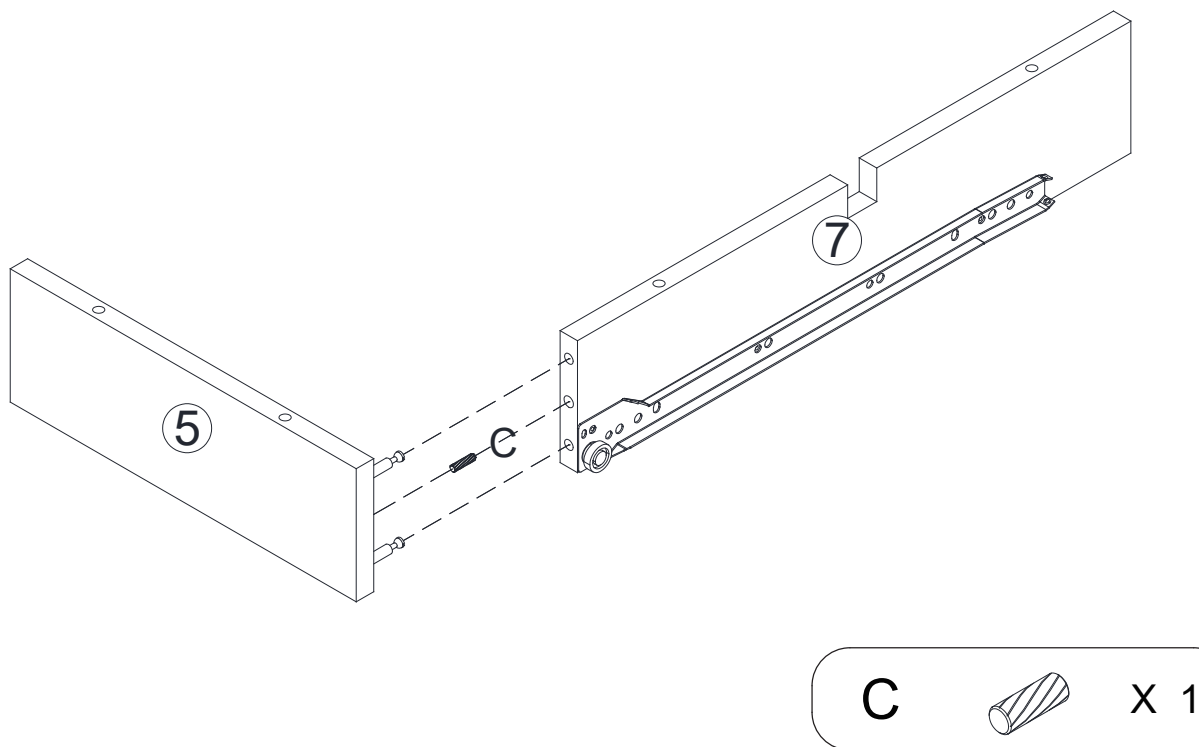

Step 9

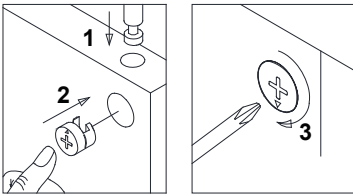
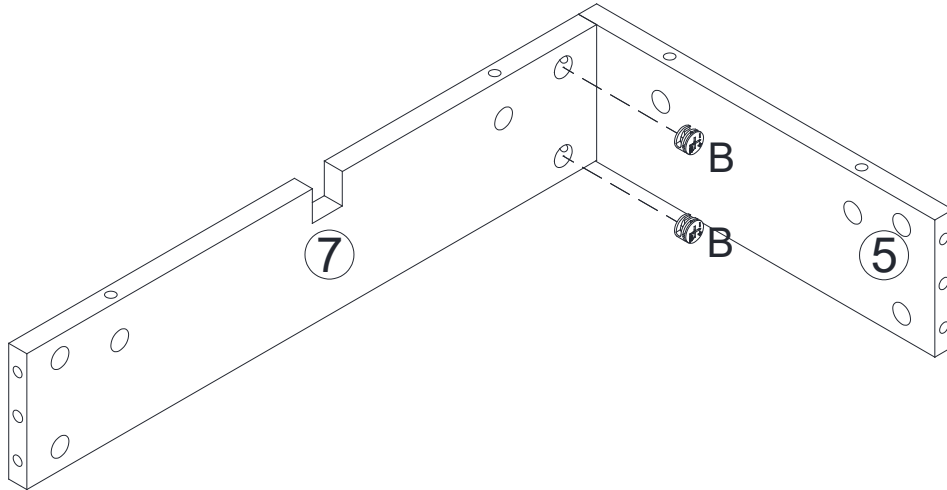

B



X 2

Step 10

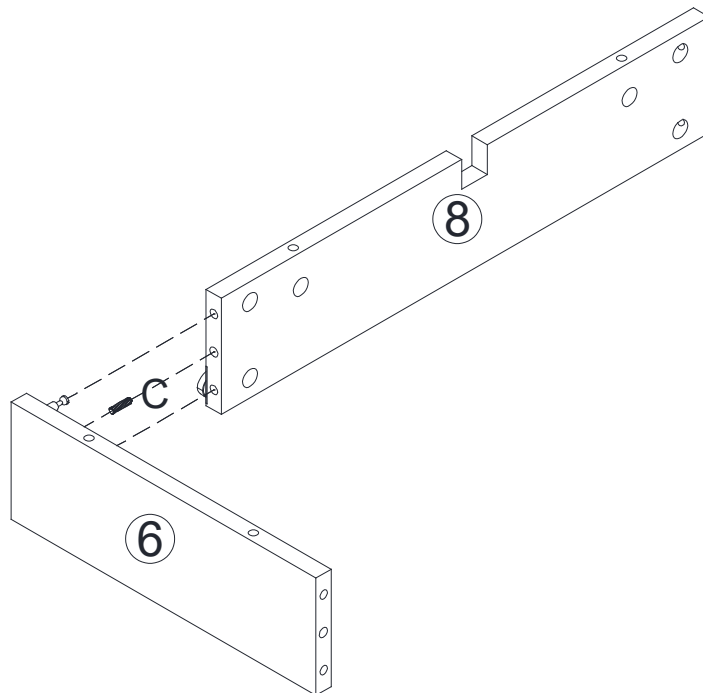

C



X 1

Step 11

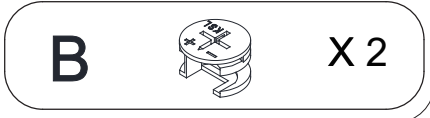
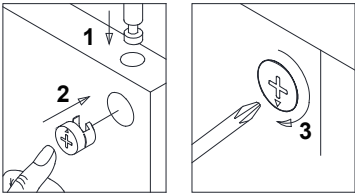
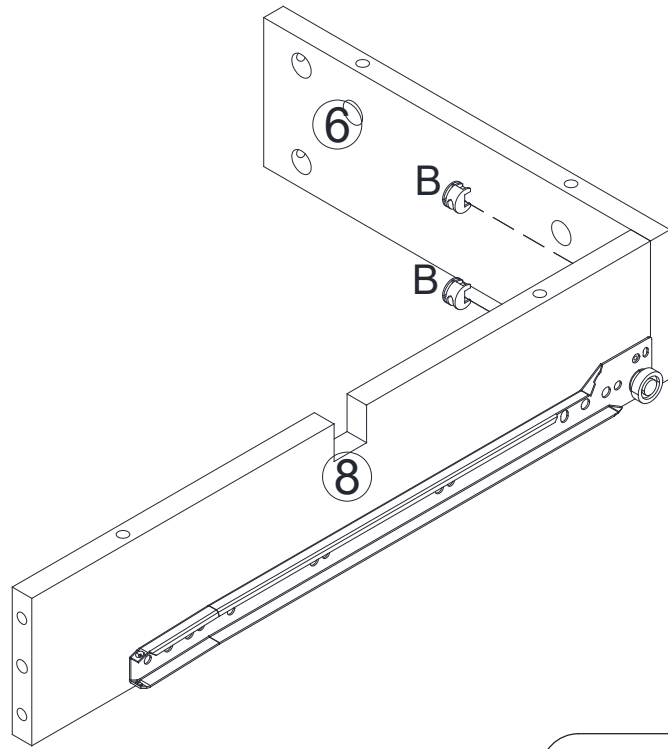

Step 12

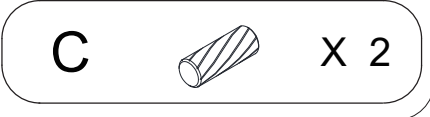
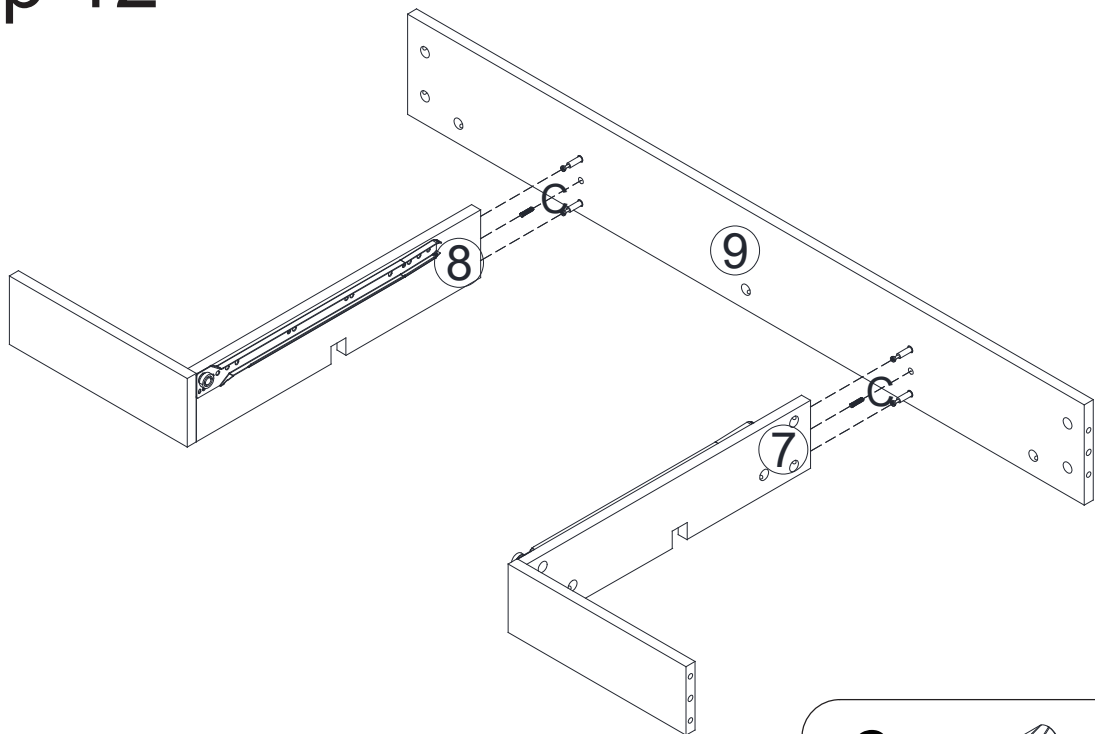

Step 13

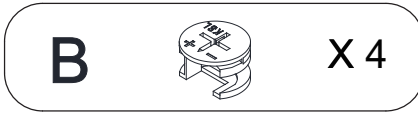
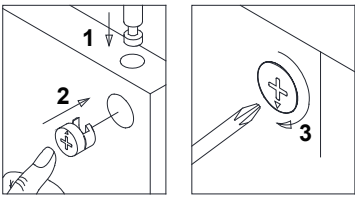
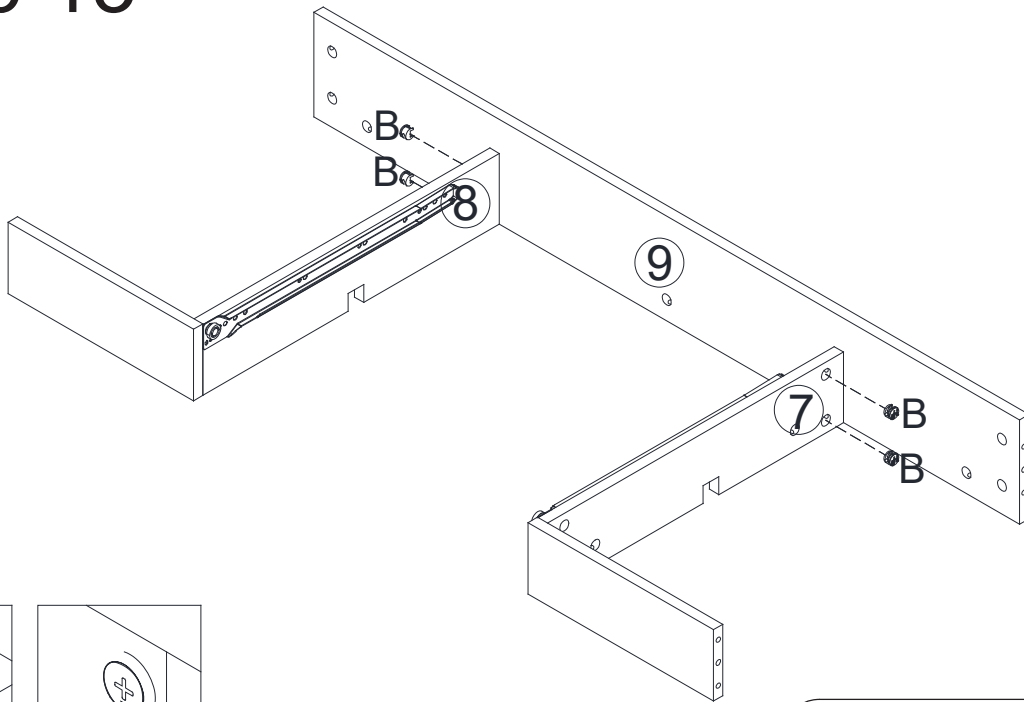

Step 14

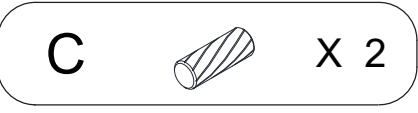
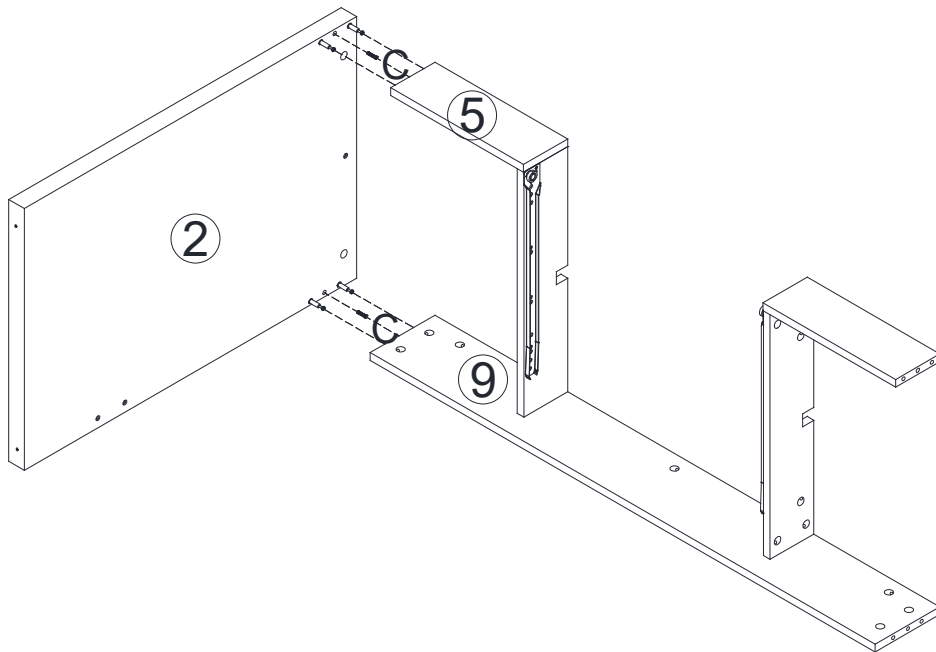

Step 15

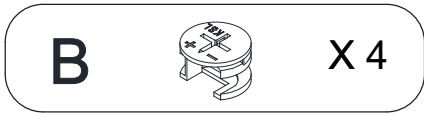
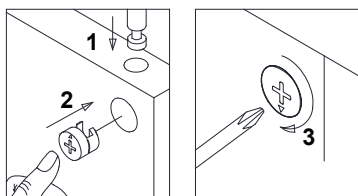
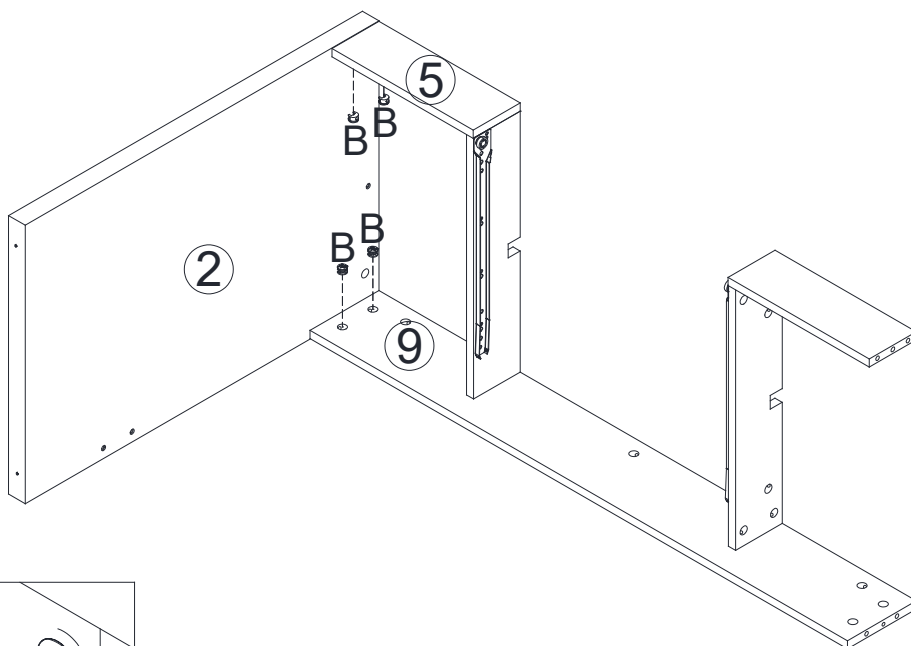

Step 16

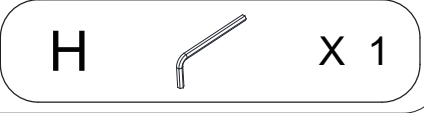
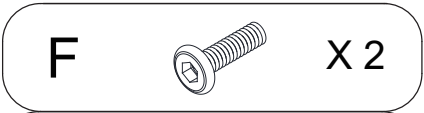
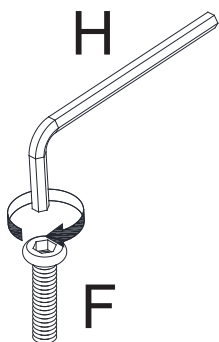
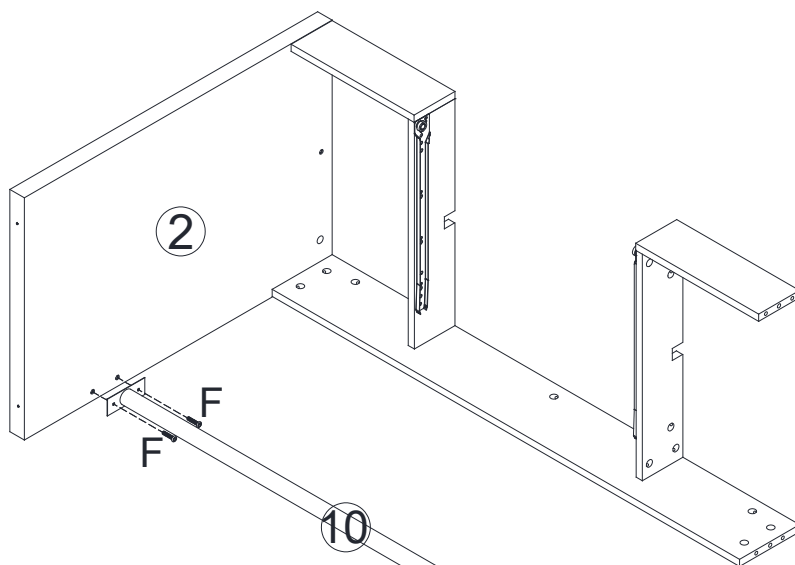

Step 17

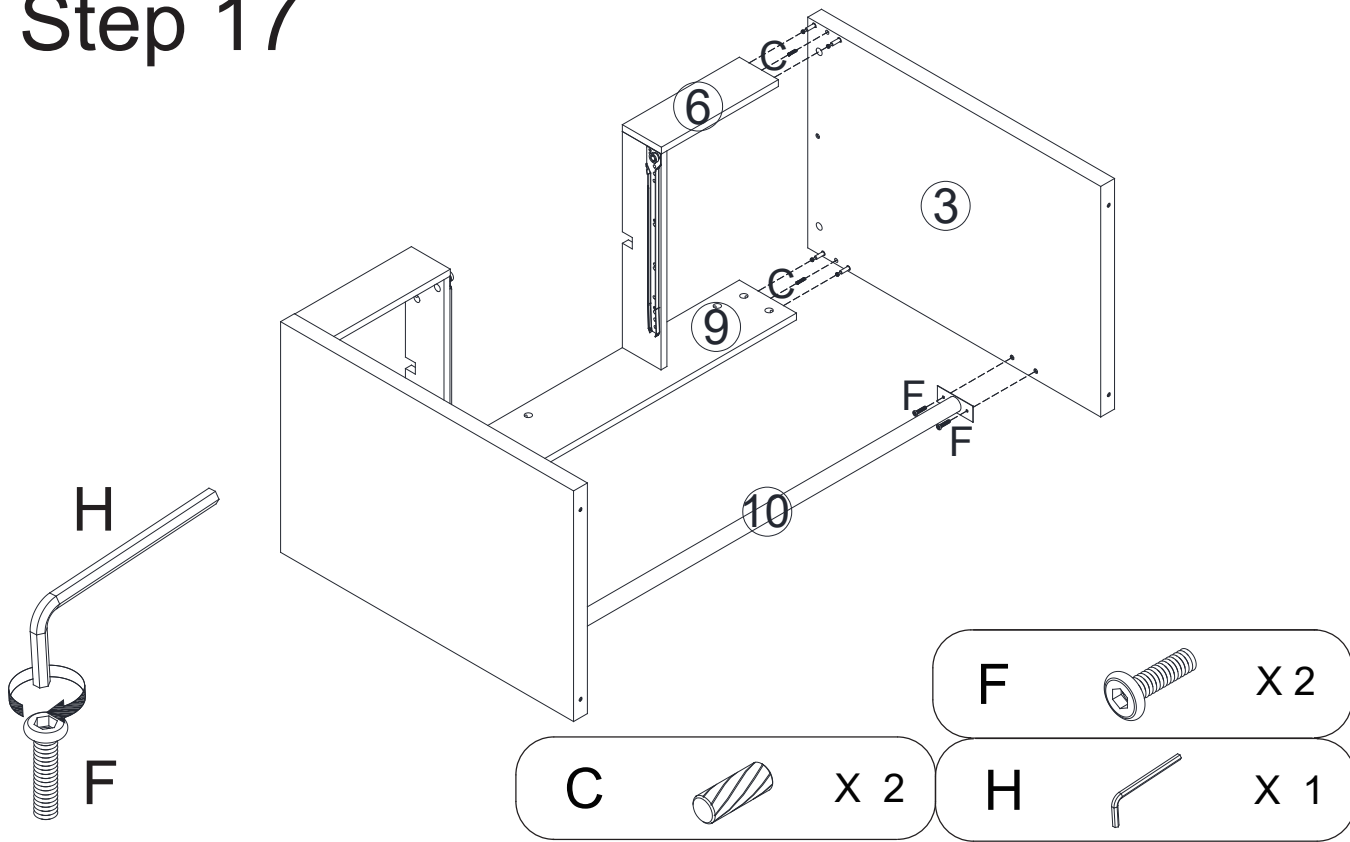

Step 18

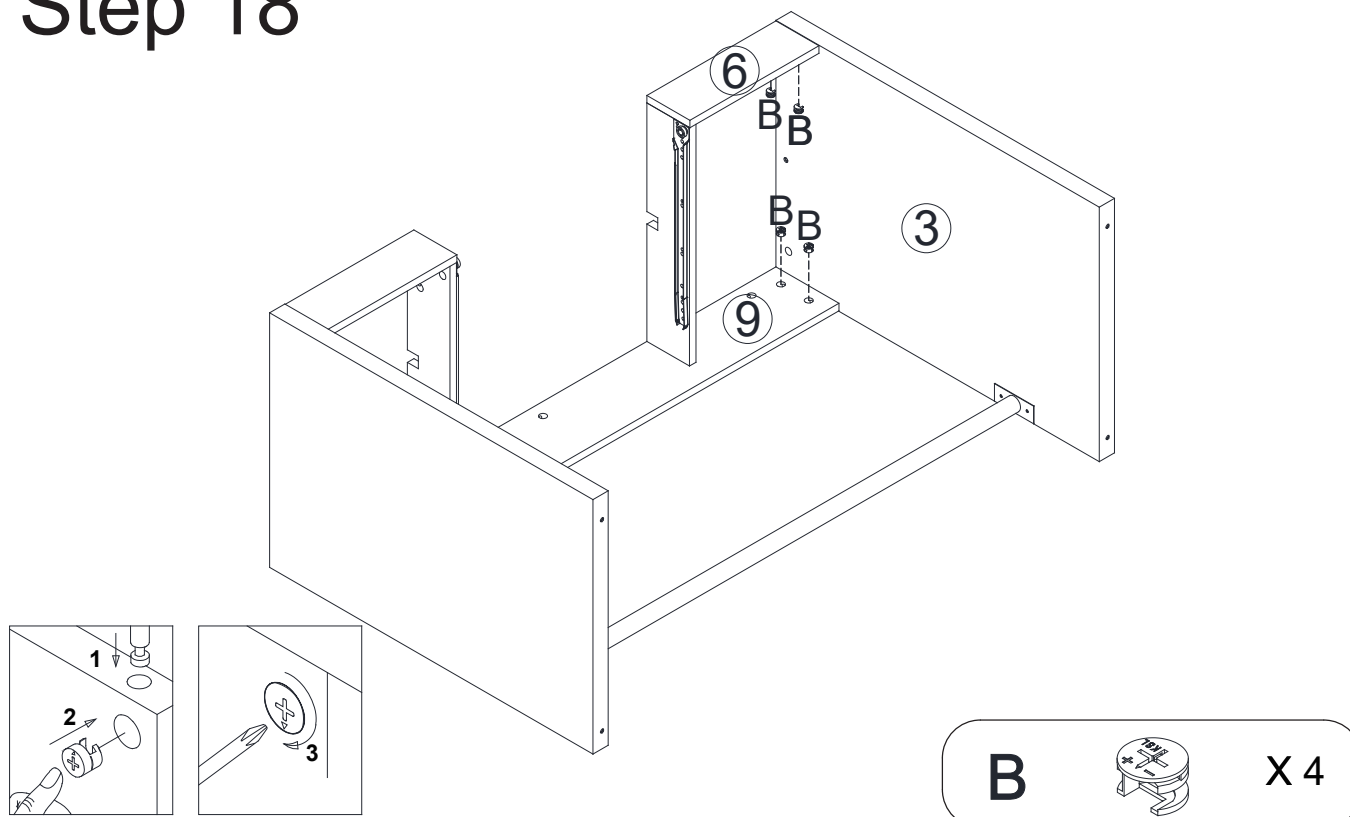

Step 19

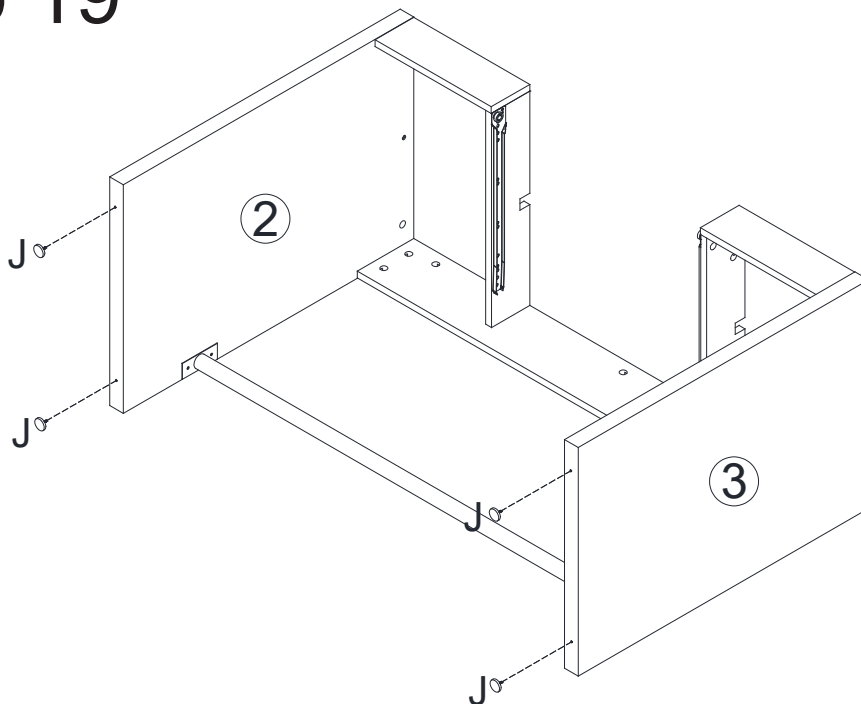

J  **X 4**

Step 20

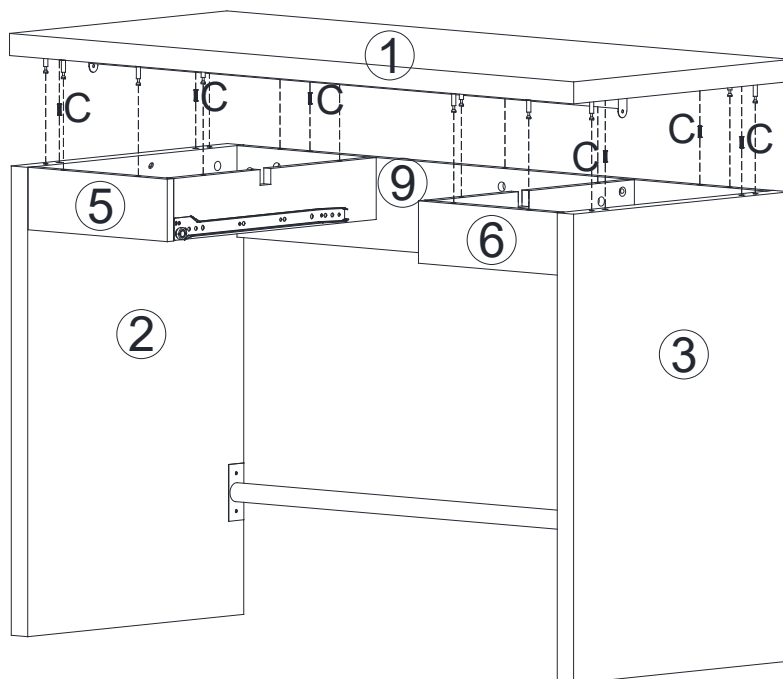

C  **X 6**

Step 21

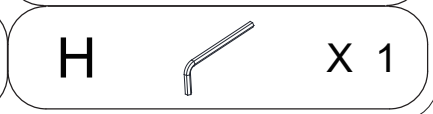
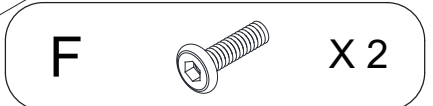
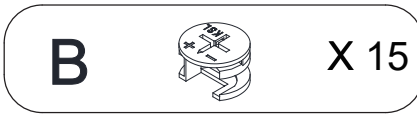
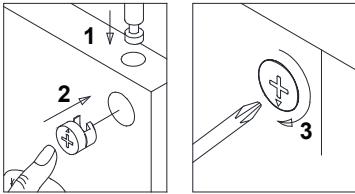
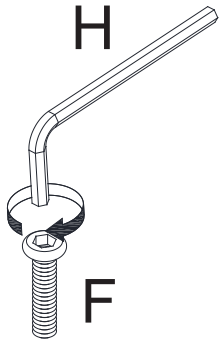
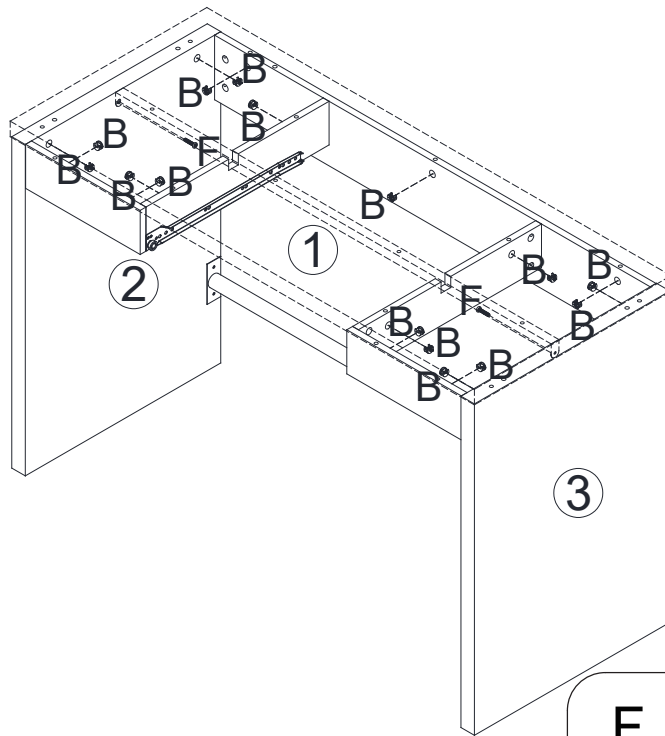

Step 22

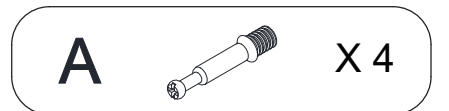
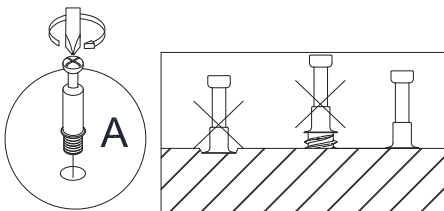
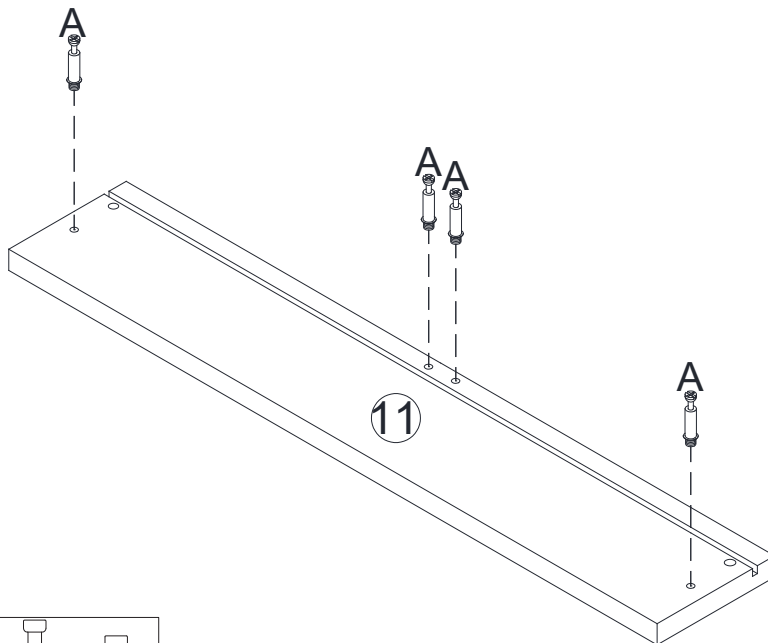

Step 23

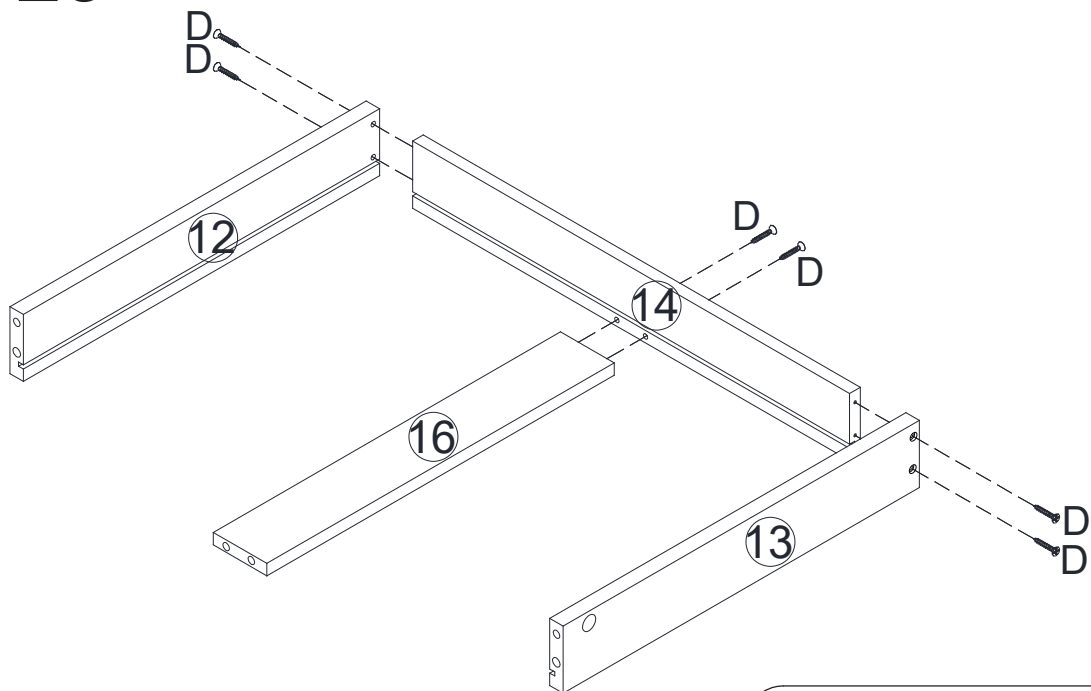

D



X 6

Step 24

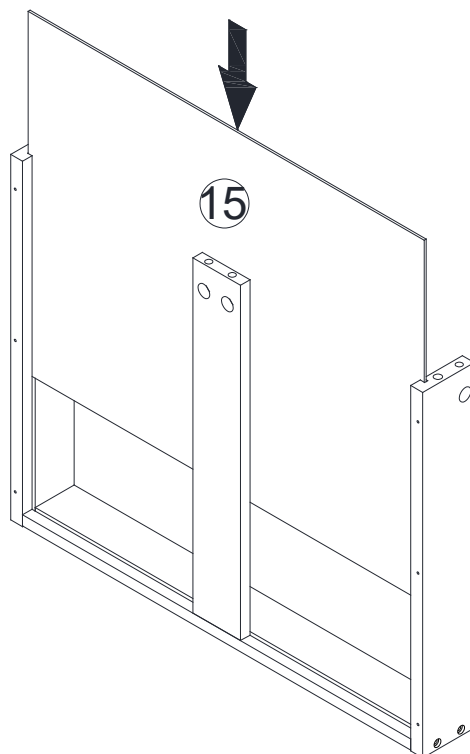

Step 25

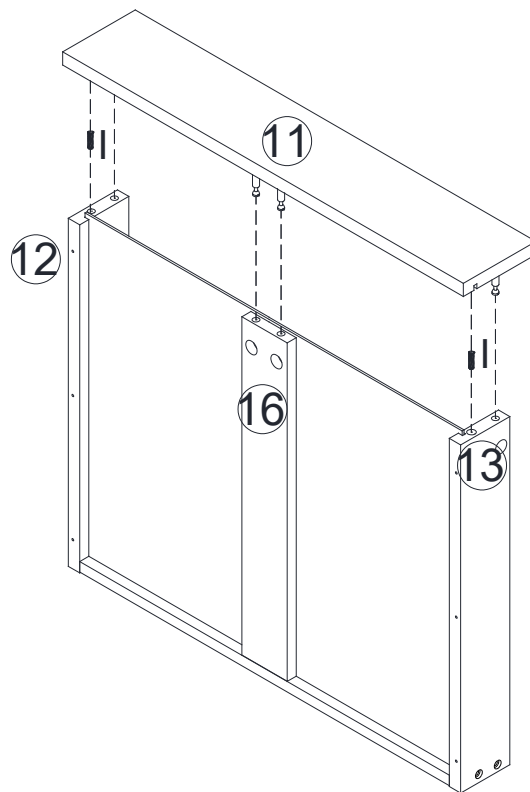

I  X 2

Step 26

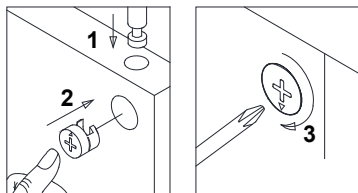
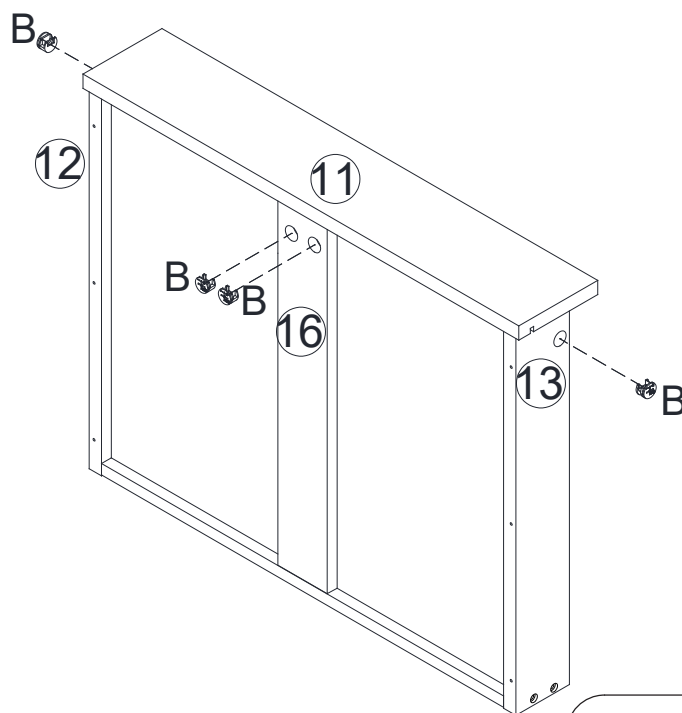

B  X 4

Step 27

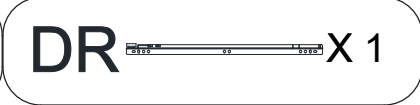
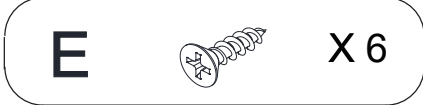
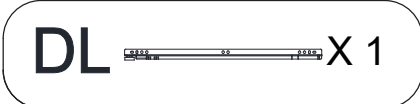
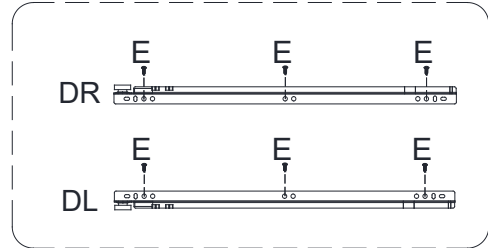
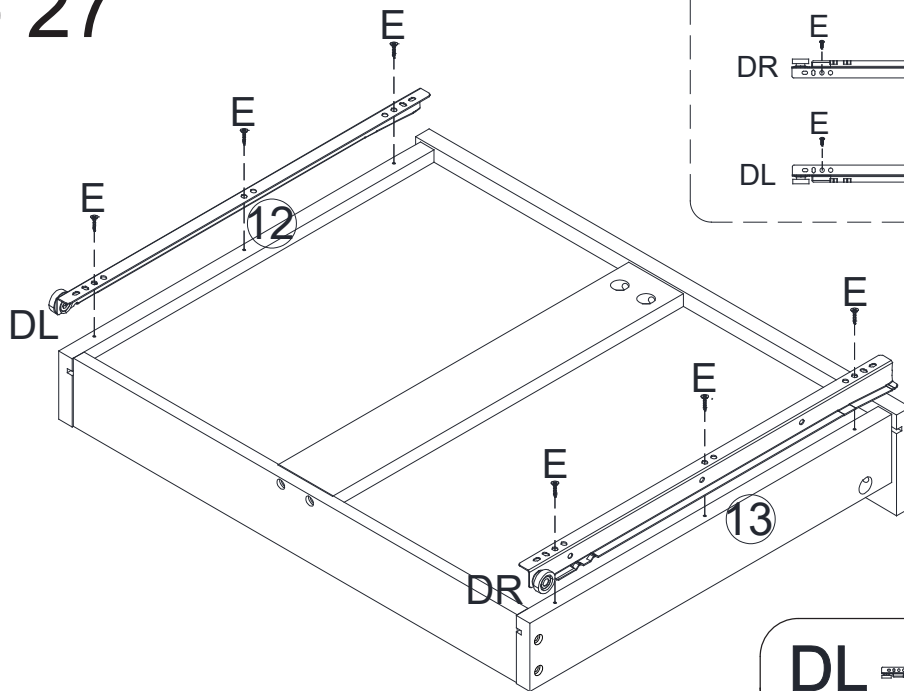

Step 28

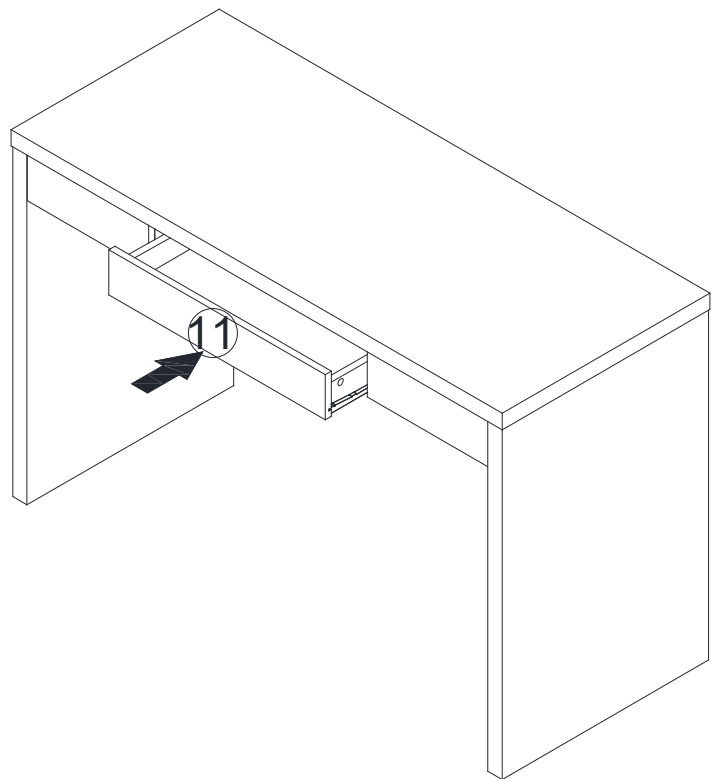
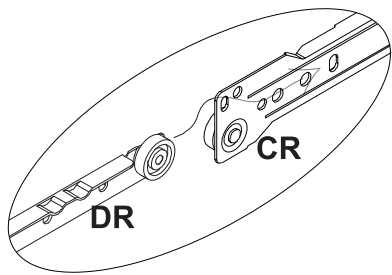
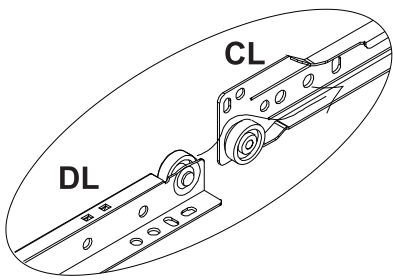

Step 29

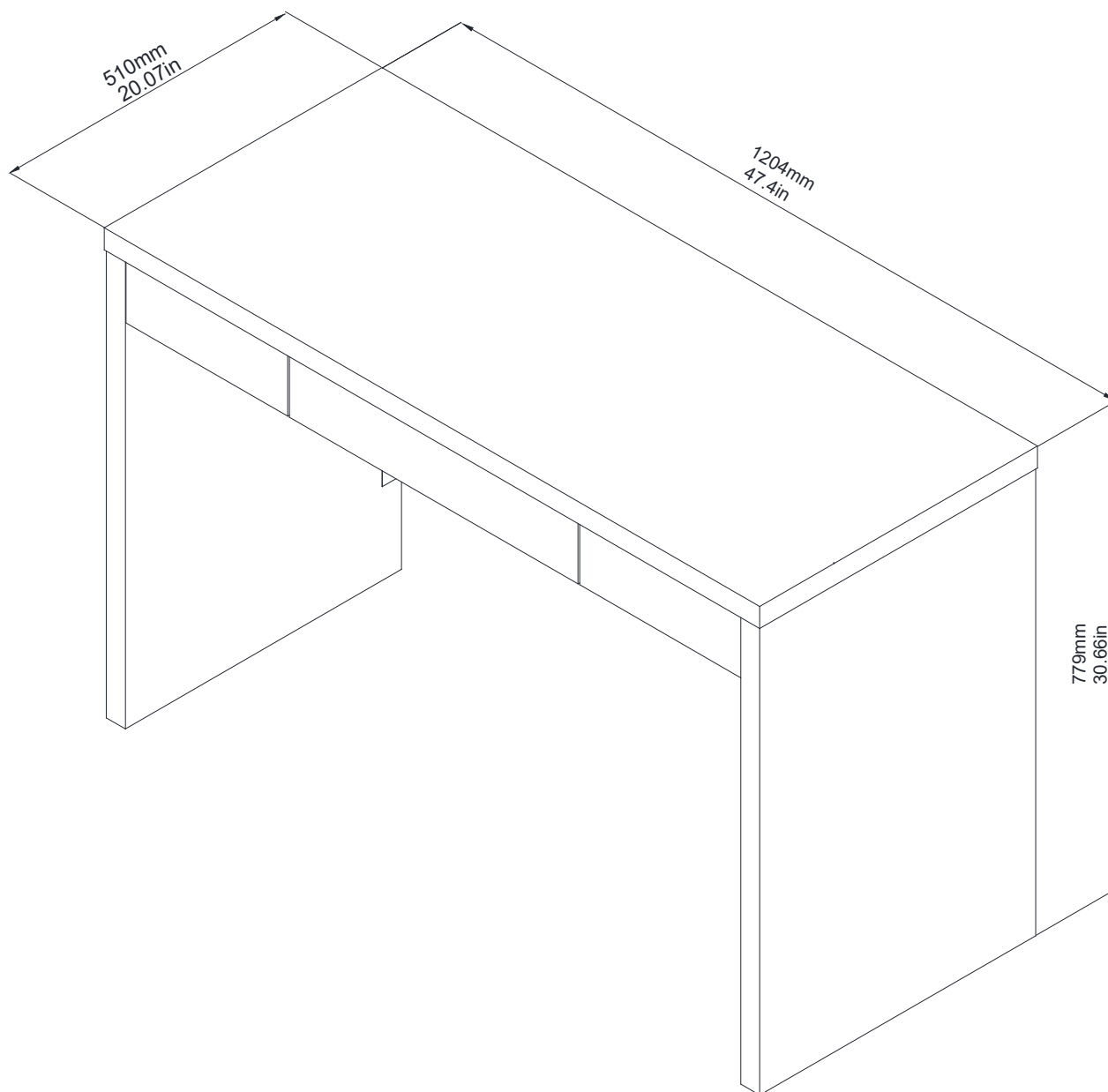

Final assmebly