

STEP 5

Unfold the Bin (5) and slide in the table.

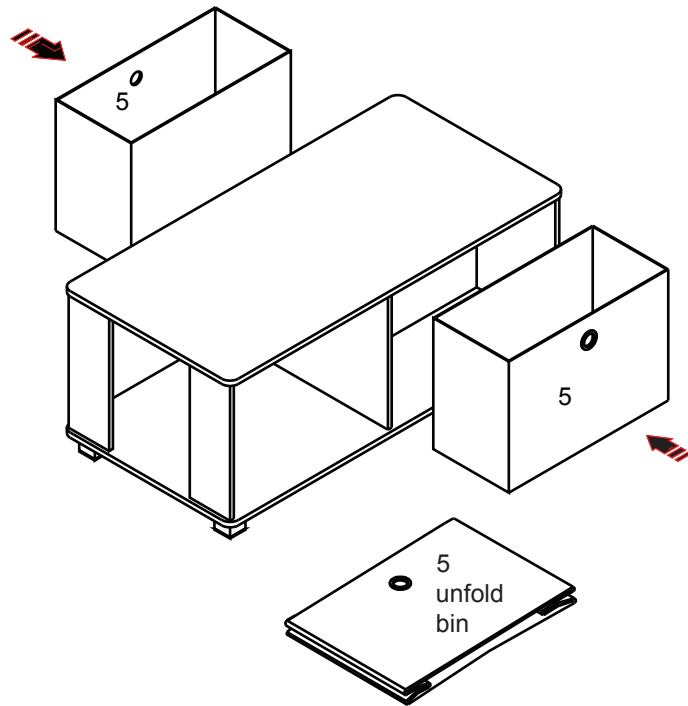

Recommended Maximum Weight

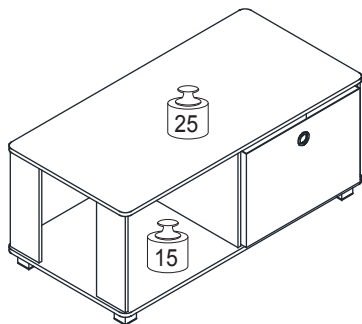

*Unit in Pound(lbs)

WARNING:

>This unit has been designed to support the maximum loads shown. Exceeding these load limits could cause sagging, instability, product collapse, and/or serious injury.

>DO NOT allow children to climb on unit.

>Put heavier items on lower shelves.

Assembly Instruction

Coffee Table with Bin Drawer

DIMENSION : 31.5"(W) x 13.75"(H) x 15.75"(D)

00:30

Approx. 30 minutes





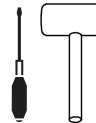



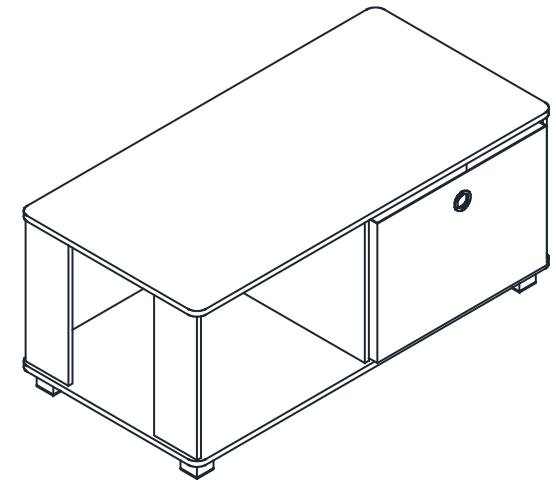



Recomm. 1 Person



Tool Required



No	Hardware List	Qty
1	C/B Screw A 	8pcs
2	C/B Screw B 	15pcs
3	Square Leg 	5pcs
4	Dowel 	12pcs
5	Non Wooven Bin 	2pcs
6	White Glue 	1pc

No	Parts List	Qty
a	Top Panel 	1pc
b	Bottom Panel 	1pc
c	Side Panel 	2pcs
d	Side Panel (Small) 	2pcs
e	Center Panel 	1pc

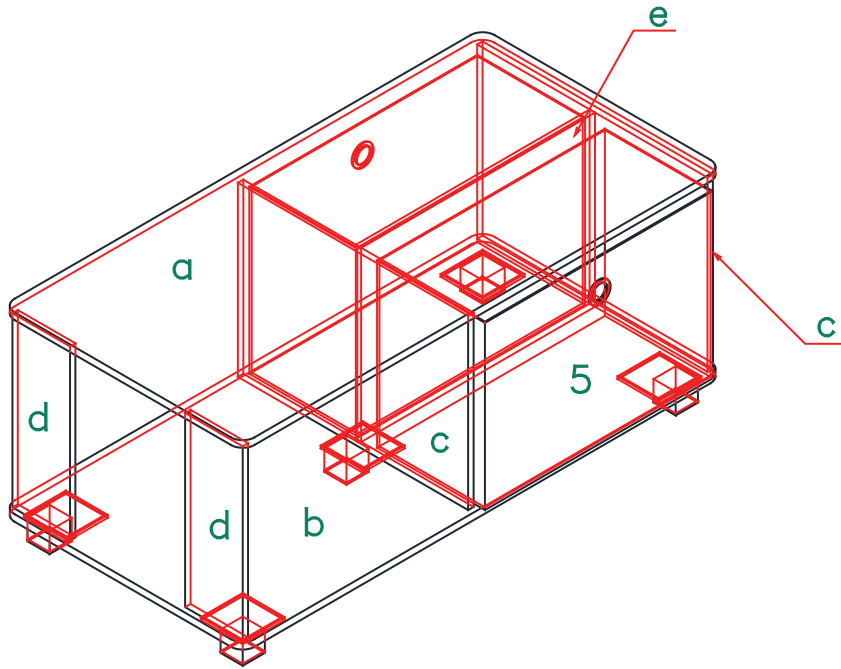

USEFUL HINTS BEFORE YOU START:

1. Read each step carefully before starting.
2. It is important that each step is performed in correct order to avoid difficulties.
3. Identify, sort and count the parts before assembly.
4. Assemble your furniture on packaging cardboard to prevent scratch or damage.
5. Clean the product with mild cleanser using soft damped cloth. Do not use harsh or abrasive cleanser.
6. Using incompatible hardware might cause damage to product.

STEP 1

Insert Dowel (4) to Side Panel (C) (D) and Center Panel (E) with Glue (6).

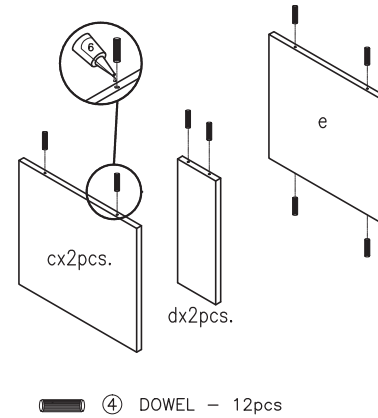

STEP 2

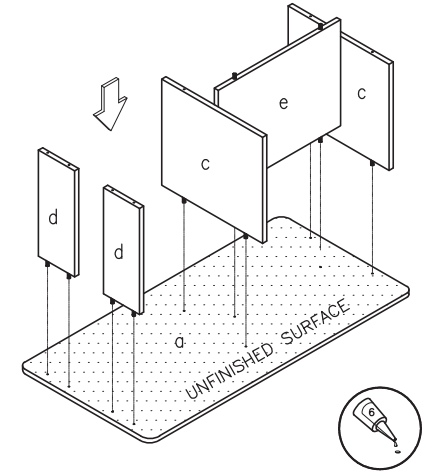

Attach Side Panel (C) (D) and Center Panel (E) to unfinished surface of Top Panel (A) with Glue (6).

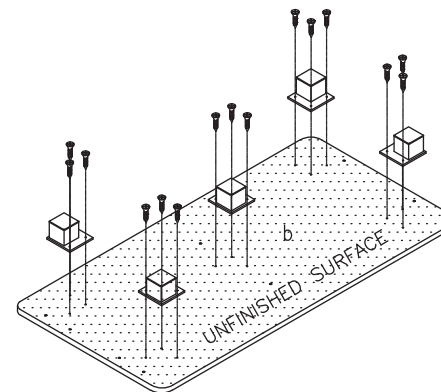

STEP 3

Attach Square Leg (3) to the unfinished surface of Bottom Panel (B) with Screw (2).
*Follow the marking on the panel.



-  ② SCREW A - 15pcs
-  ③ SQUARE LEG - 5pcs

STEP 4

Attach Bottom Panel (B) to assembled unit with Screw (1). Using Glue (6) to attach with Dowel on Center Panel (E).

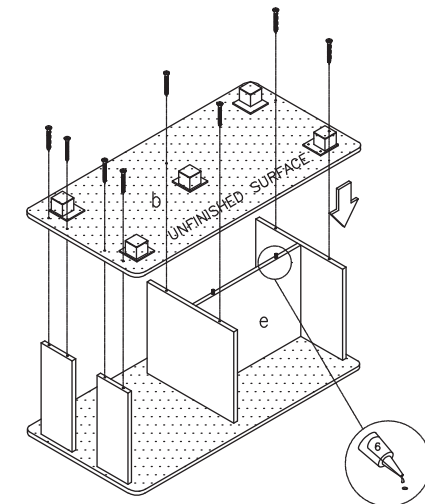

-  ① SCREW B - 8pcs