

Montageanleitung | Instructions de montage Assembly Instructions | Instrucciones de montaje

SKU NUMBER: N601P436914, N601P436915

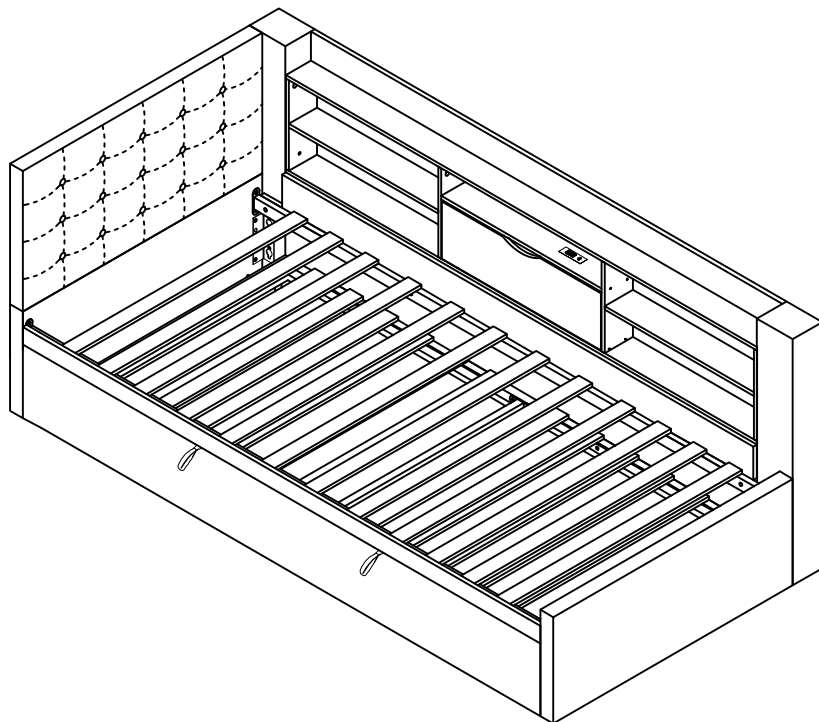

GB This set comes in 2 boxes. If you do not receive a full set of 2 boxes, please contact our customer service.

DE Dieses Set wird in 2 Schachteln geliefert. Wenn Sie nicht ein komplettes Set von 2 Boxen erhalten, kontaktieren Sie bitte unseren Kundenservice.

FR Ce set est livré en 2 boîtes. Si vous ne recevez pas un jeu complet de 2 boîtes, veuillez contacter notre service clientèle.

**UK
CA**



English**IMPORTANT ! KEEP FOR FUTURE REFERENCE : READ CAREFULLY**

- To be assembled by an adult. Assembly must be checked by an adult before use
- WARNING ! Keep all screws, small parts and plastic bags out of the reach of children
- Properly identify all parts before assembling
- Never use your item if any of its parts are broken or missing
- Should any problems arise, please contact our After Sales Service
- Manufacturer's instructions shall be followed at all times
- Care: Clean with a soft, dry cloth. In case of larger stains, carefully rub with a slightly damp, non-abrasive sponge
- Avoid the risk of fire by not placing furniture near sources of ignition or hot items
- Do not jump on the bed

Deutsch**WICHTIG ! ZUM SPÄTEREN NACHSCHLAGEN AUFBEWAHREN: SORGFÄLTIG LESEN**

- Muss von einem Erwachsenen zusammengebaut werden. Der Zusammenbau muss vor dem Gebrauch von einem Erwachsenen überprüft werden
- WARNUNG! Bewahren Sie alle Schrauben, Kleinteile und Plastikbeutel außerhalb der Reichweite von Kindern auf
- Kennzeichnen Sie vor dem Zusammenbau alle Teile richtig
- Benutzen Sie Ihren Artikel niemals, wenn Teile gebrochen sind oder fehlen
- Sollten Probleme auftreten, wenden Sie sich bitte an unseren Kundendienst
- Die Anweisungen des Herstellers sind stets zu befolgen
- Pflege: Mit einem weichen, trockenen Tuch reinigen. Bei größeren Flecken vorsichtig mit einem leicht feuchten, nicht scheuernden Schwamm abreiben. nicht scheuernden Schwamm
- Vermeiden Sie die Gefahr eines Brandes, indem Sie die Möbel nicht in der Nähe von Zündquellen oder heißen Gegenständen aufstellen
- Nicht auf das Bett springen

Français**IMPORTANT ! CONSERVER POUR RÉFÉRENCE ULTÉRIEURE : LIRE ATTENTIVEMENT**

- Le montage doit être effectué par un adulte. Le montage doit être vérifié par un adulte avant Utilisation
- ATTENTION ! Tenir les vis, les petites pièces et les sachets en plastique hors de portée des enfants
- Identifiez correctement toutes les pièces avant de les assembler
- N'utilisez jamais votre article si l'une de ses pièces est cassée ou manquante
- En cas de problème, veuillez contacter notre service après-vente
- Les instructions du fabricant doivent être respectées à tout moment
- Entretien : nettoyer avec un chiffon doux et sec. En cas de taches plus importantes, frotter soigneusement avec une éponge non abrasive légèrement humide. légèrement humide et non Abrasive
- Évitez les risques d'incendie en ne plaçant pas les meubles à proximité de sources d'inflammation ou d'objets chauds
- Ne pas sauter sur le lit

Italiano

IMPORTANTE! CONSERVARE PER RIFERIMENTO FUTURO: LEGGERE ATTENTAMENTE

- Deve essere assemblato da un adulto. L'assemblaggio deve essere controllato da un adulto prima dell'uso
- ATTENZIONE! Tenere tutte le viti, le piccole parti e i sacchetti di plastica fuori dalla portata dei bambini
- Identificare correttamente tutte le parti prima dell'assemblaggio
- Non utilizzare mai l'articolo se alcune parti sono rotte o mancanti
- In caso di problemi, si prega di contattare il nostro Servizio Post Vendita
- Le istruzioni del produttore devono essere sempre seguite
- Cura: Pulire con un panno morbido e asciutto. In caso di macchie più estese, strofinare accuratamente con una spugna leggermente umida e nonspugna leggermente umida e non abrasiva
- Evitare il rischio di incendio, non collocando i mobili vicino a fonti di accensione o a oggetti caldi
- Non saltare sul letto

Español

¡IMPORTANTE ! CONSERVELO PARA FUTURAS CONSULTAS: LEA ATENTAMENTE

- Debe ser montado por un adulto. El montaje debe ser comprobado por un adulto antes del uso
- ADVERTENCIA Mantenga todos los tornillos, piezas pequeñas y bolsas de plástico fuera del alcance de los niños.
- Identifique correctamente todas las piezas antes de montarlas
- Nunca utilice su artículo si alguna de sus piezas está rota o falta
- Si surge algún problema, póngase en contacto con nuestro Servicio Postventa
- Las instrucciones del fabricante deben seguirse en todo momento
- Cuidado: Limpiar con un paño suave y seco. En caso de manchas más grandes, frote cuidadosamente con una esponja no abrasiva ligeramente humedecida.
- Evite el riesgo de incendio no colocando los muebles cerca de fuentes de ignición u objetos calientes.
- No saltar sobre la cama.

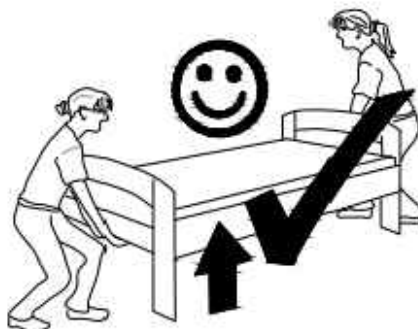

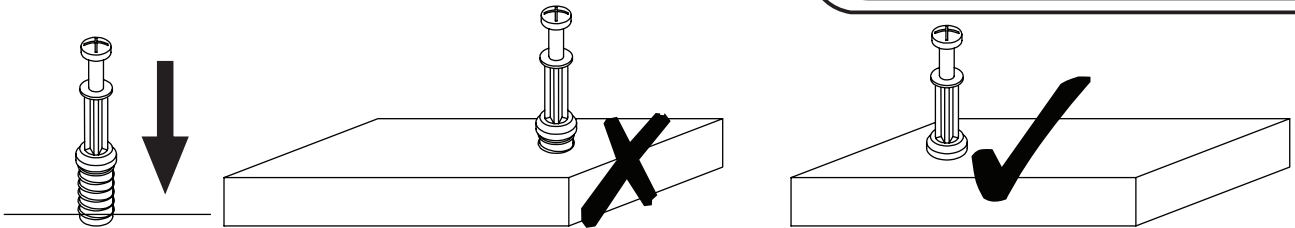

EN_QUICKFIT: Tighten quickfit until shoulder is flush with panel. Do not overtighten or undertighten.

FR_RACCORD RAPIDE: Faites serrer le raccord rapide jusqu'à ce que l'épaulement soit parfaitement encastré dans le panneau. Il ne faut ni trop serrer ni insuffisamment serrer.

ES_QUICKFIT: Apriete quickfit hasta que el hombro se descargue con el panel. NO lo sobreapriete ni lo apriete poco.

DE_QUICKFIT: Ziehen Sie den Quickfit fest, bis die Schulter mit der Platte bündig ist. Bitte nicht zu fest oder zu schwach anziehen.

IT_MONTAGGIO RAPIDO: Stringere il montaggio rapido fino a quando la spalla è a filo con il pannello, non stringere troppo o troppo poco.

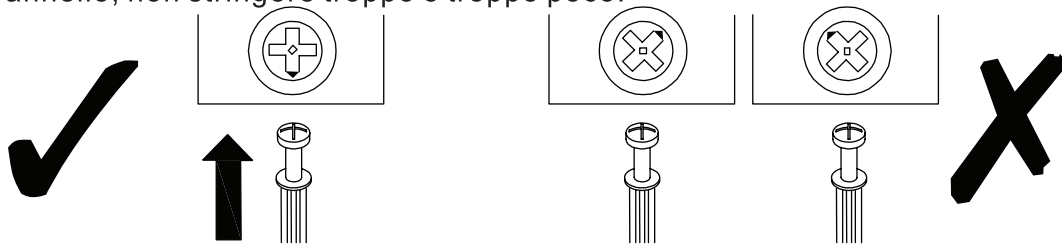

EN_CAM LOCK: When fitting cam lock, ensure starting position is correct before you insert connecting quickfit.

FR_SERRURE BATTEUSE: Avant d'insérer la serrure batteuse, veillez à la bonne orientation avant d'insérer le raccord rapide.

ES_CIERRE DE LA CÁMARA: Cuando instale el cierre de la cámara, asegúrese de que la posición de inicio es correcta antes de que inserte el quickfit conector.

DE_CAM-LOCK: Achten Sie bei der Montage des Cam-Locks auf die richtige Ausgangsposition, bevor Sie den Quickfit einsetzen.

IT_BLOCCAGGIO A CAMMA: Quando si monta il bloccaggio a camma, assicurarsi che la posizione iniziale sia corretta prima di inserire il montaggio rapido di collegamento.

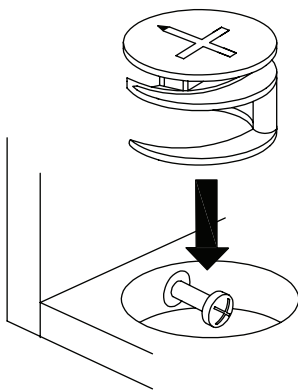

EN_Quickfit head should be in the centre of the cam lock when the two panels are joined.

Cam lock should be inserted before quickfit.

FR_Lorsque les deux panneaux sont assemblés, la tête du raccord rapide doit reposer au centre de la serrure batteuse. Il faut insérer la serrure batteuse avant le raccord rapide.

ES_El cabezal del quickfit debe estar en el centro del cierre de la cámara cuando se unan los dos paneles.

Se debe insertar el cierre de la cámara antes que el quickfit.

DE_Der Quickfit-Kopf sollte sich in der Mitte des Cam-Locks befinden, wenn die beiden Platten zusammengefügt sind. Der Cam-Lock sollte vor dem Quickfit eingesetzt werden.

IT_La testa del montaggio rapido deve trovarsi al centro del bloccaggio a camma quando i due pannelli sono uniti.

Il Bloccaggio a Camma deve essere inserito prima del montaggio rapido.

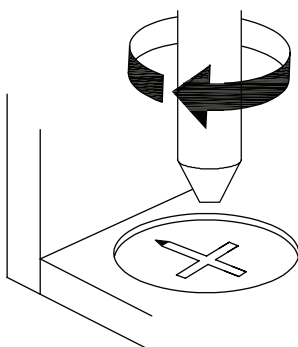

EN_Turn cam lock clockwise to tighten.

FR_Faites tourner la serrure batteuse dans le sens des aiguilles d'une montre pour la resserrer.

ES_Gire el cierre de la cámara en sentido horario para apretarlo.

DE_Drehen Sie den Cam-Lock im Uhrzeigersinn, um ihn festzuziehen.

IT_Ruotare il bloccaggio a camma in senso orario per stringere.

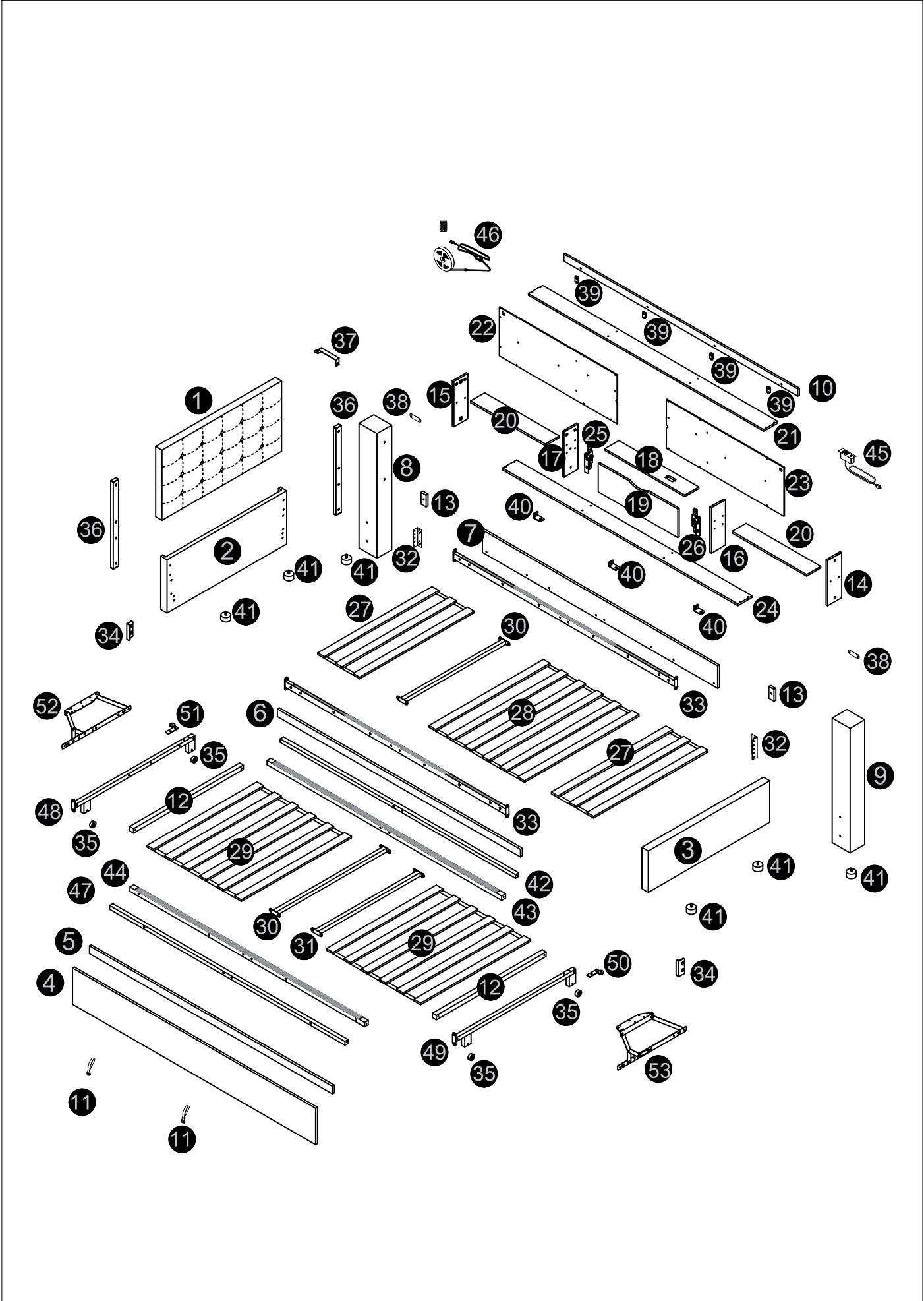

N601P436914

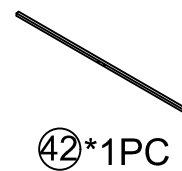
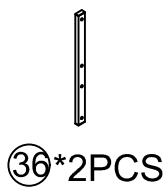
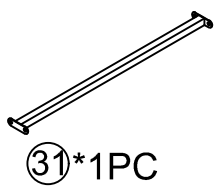
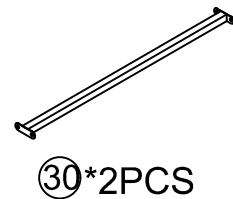
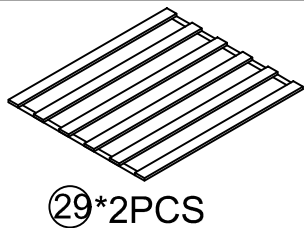
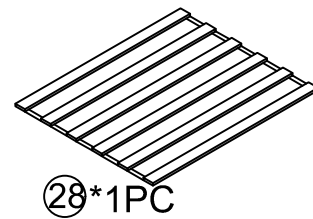
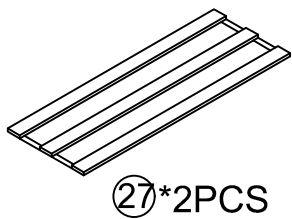
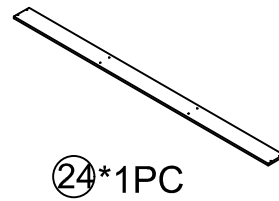
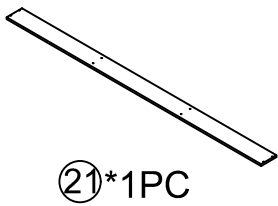
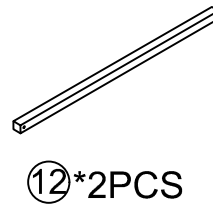
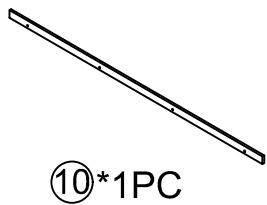
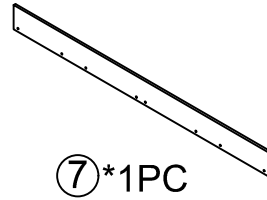
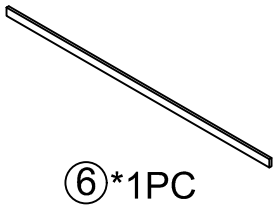
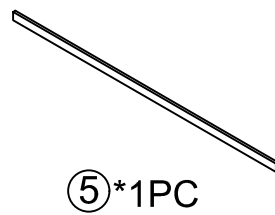
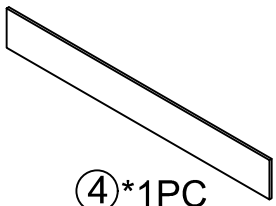

N601P436914

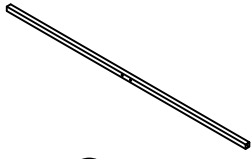

④③*1PC

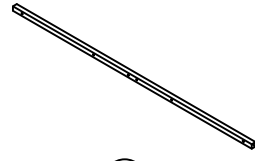

④④*1PC



④⑦*1PC

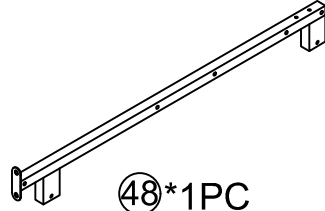

④⑧*1PC

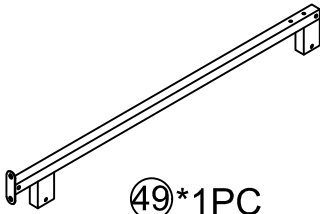

④⑨*1PC

N601P436915

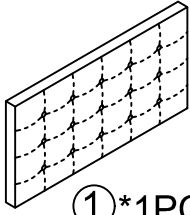

①*1PC

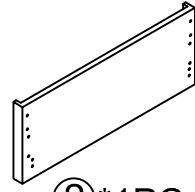

②*1PC

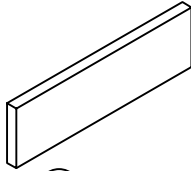

③*1PC



⑧*1PC



⑨*1PC



⑪*2PCS



⑬*2PCS

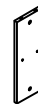

⑭*1PC



⑮*1PC



⑯*1PC

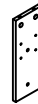

⑰*1PC

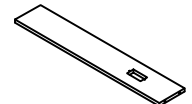

⑱*1PC

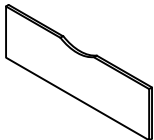

⑲*1PC

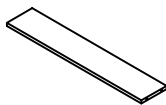

⑳*2PCS

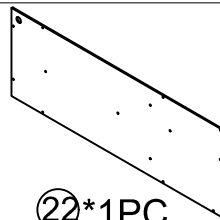

㉒*1PC

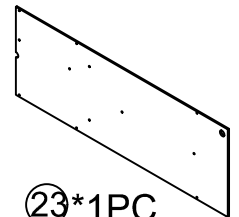

㉓*1PC



㉕*1PC



㉖*1PC



㉚*2PCS



㉜*2PCS



㉝*4PCS



㉟*1PC









㉞*2PCS







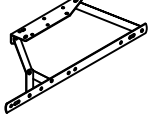
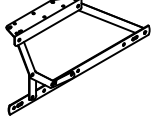



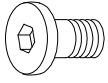
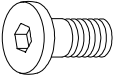
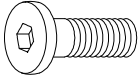
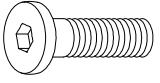
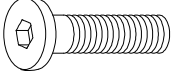
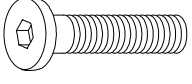

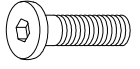
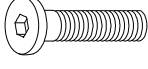
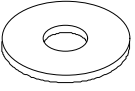

㉟*4PCS

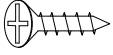
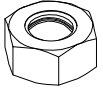
N601P436915

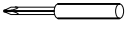
 ④0*3PCS	 ④1*6PCS	 ④5*1PC	 ④6*1PC
 ⑤0*1PC	 ⑤1*1PC	 ⑤2*1PC	 ⑤3*1PC

Hardware List-Hardwareliste N601P436915

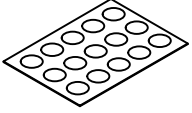
 M8×10 mm A*17PCS	 M8×16 mm B*43PCS	 M8×35 mm C*24PCS	 M8×40 mm D*12PCS
 M8×45 mm E*2PCS	 M8×50 mm F*2PCS	 M6×16 mm G*8PCS	 M6×35 mm H*4PCS
 M6×50 mm I*8PCS	 Ø8×22 mm J*14PCS	 M5×40 mm K*48PCS	 36 mm L*8PCS
 Ø15 mm M*8PCS	 M3×12 mm N*2PCS	 M6 O*4PCS	 M6 Spanner P*1PC
 Spanner Q*1PC	 S3 R*1PC	 S4 S*1PC	 S5 T*1PC
 decorative tape U*1PC			

L:

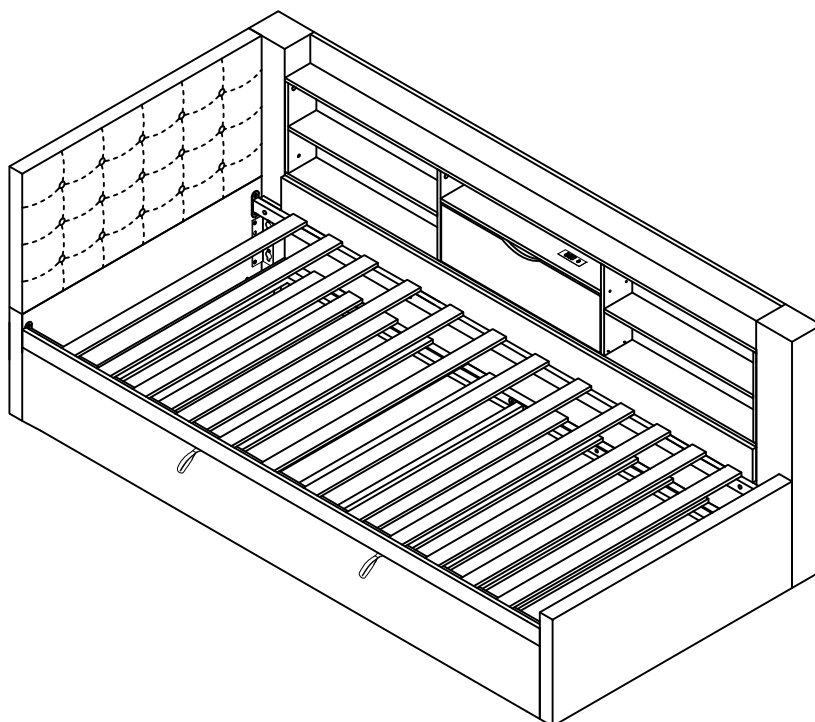

R:

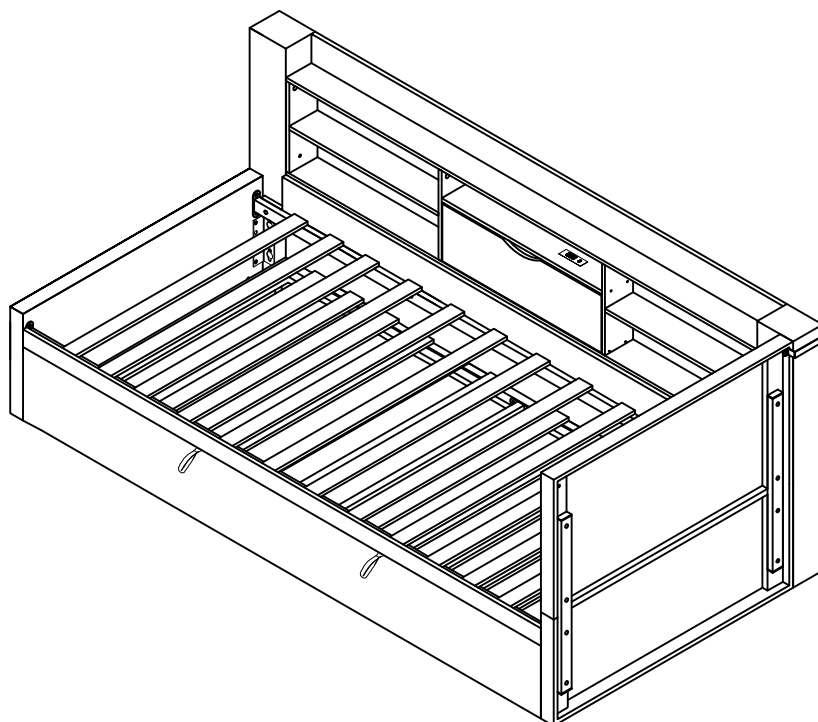

1 N*2
M3×12

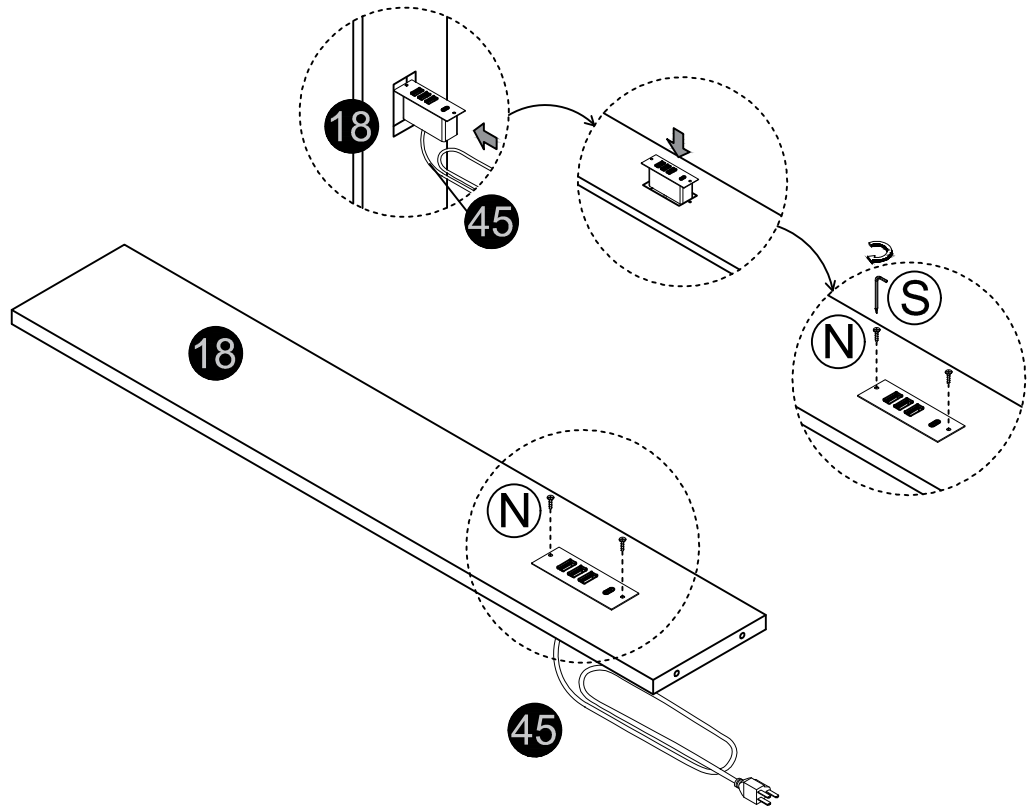

2 K*4
M5×40

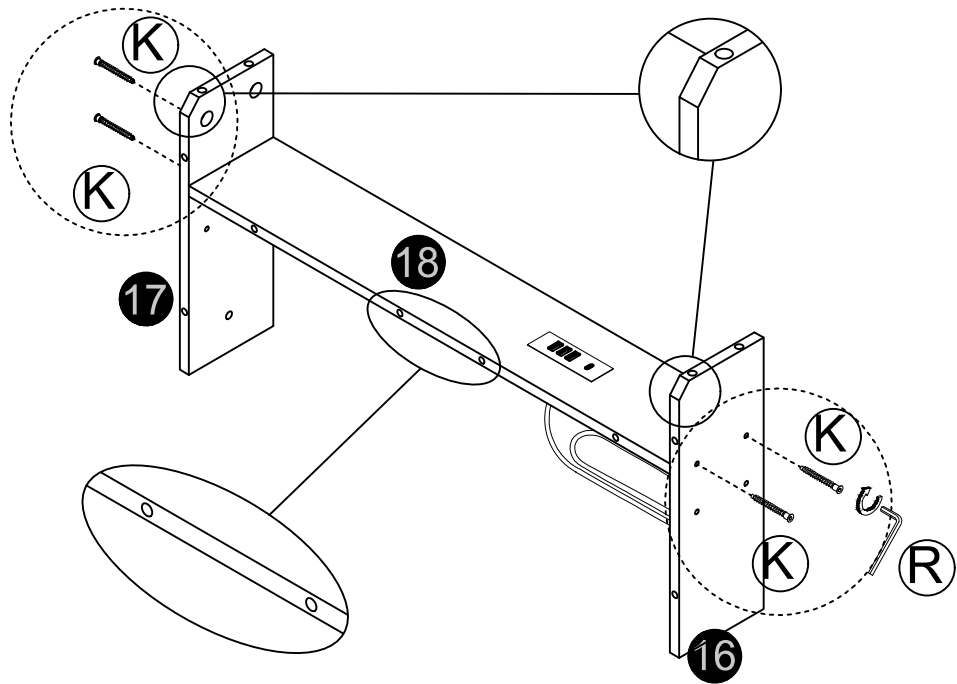

3 K*4
M5×40

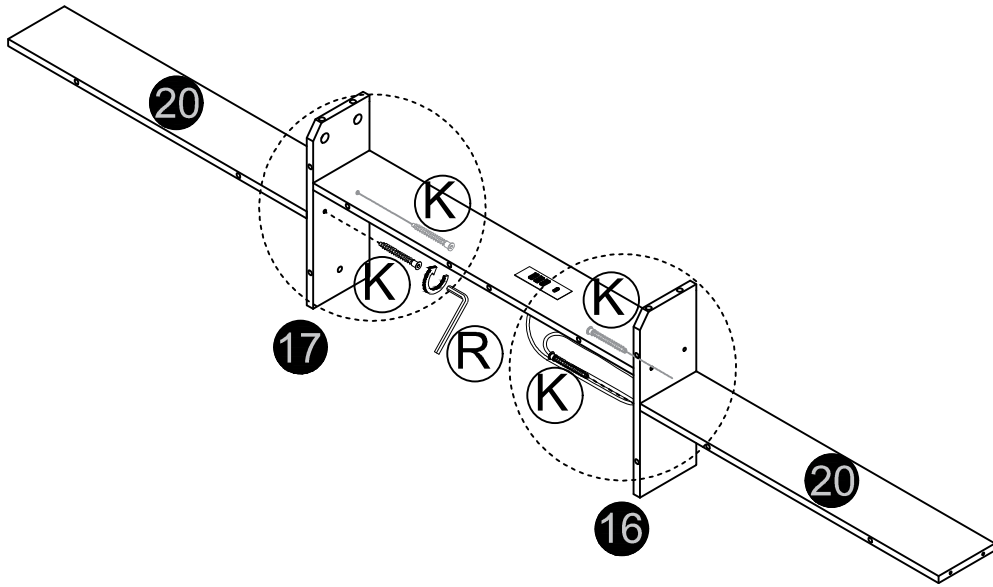

4 K*4
M5×40

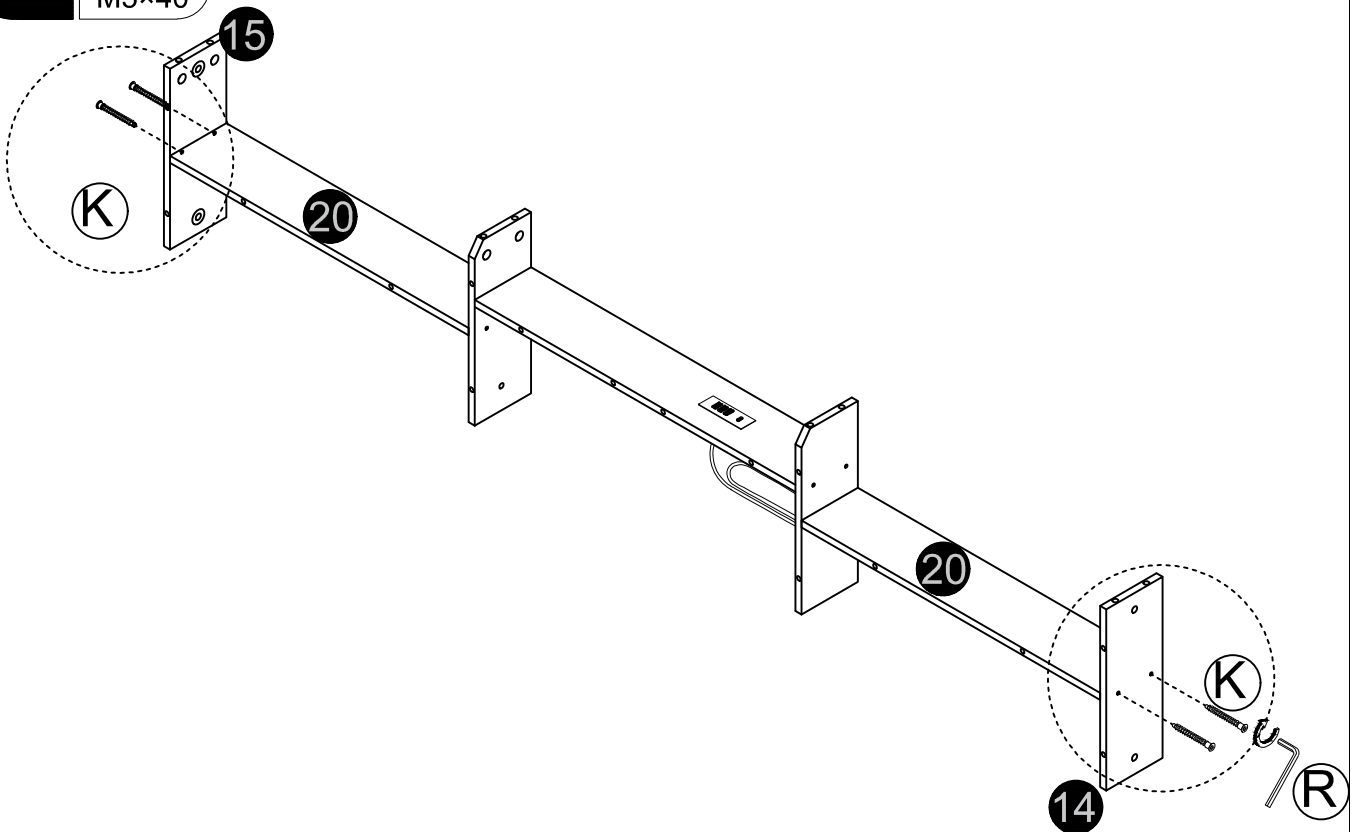

5 L*8
36MM

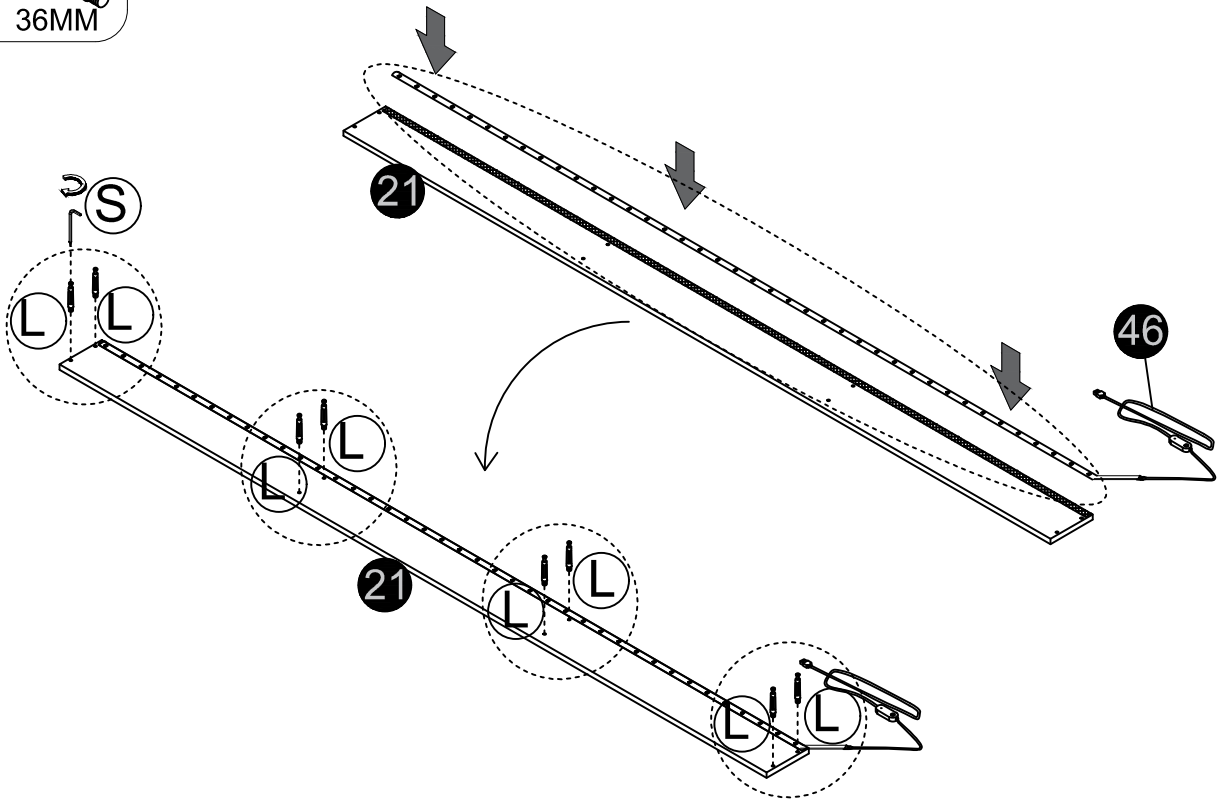

6 M*8
Ø15MM

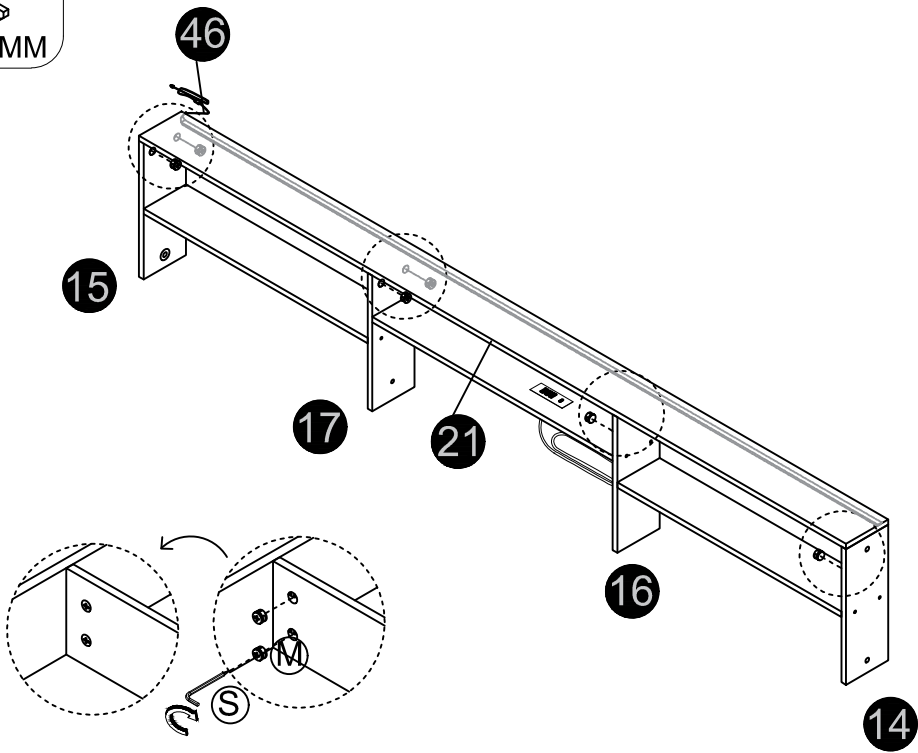

7

K*8
M5×40

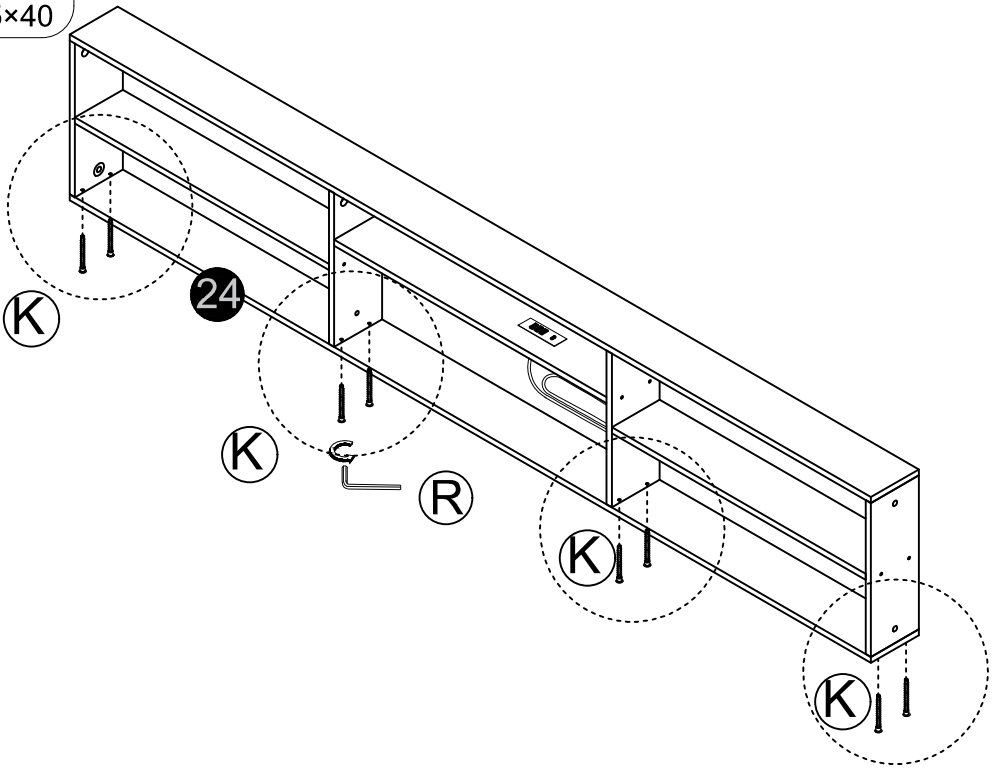

8

K*28
M5×40

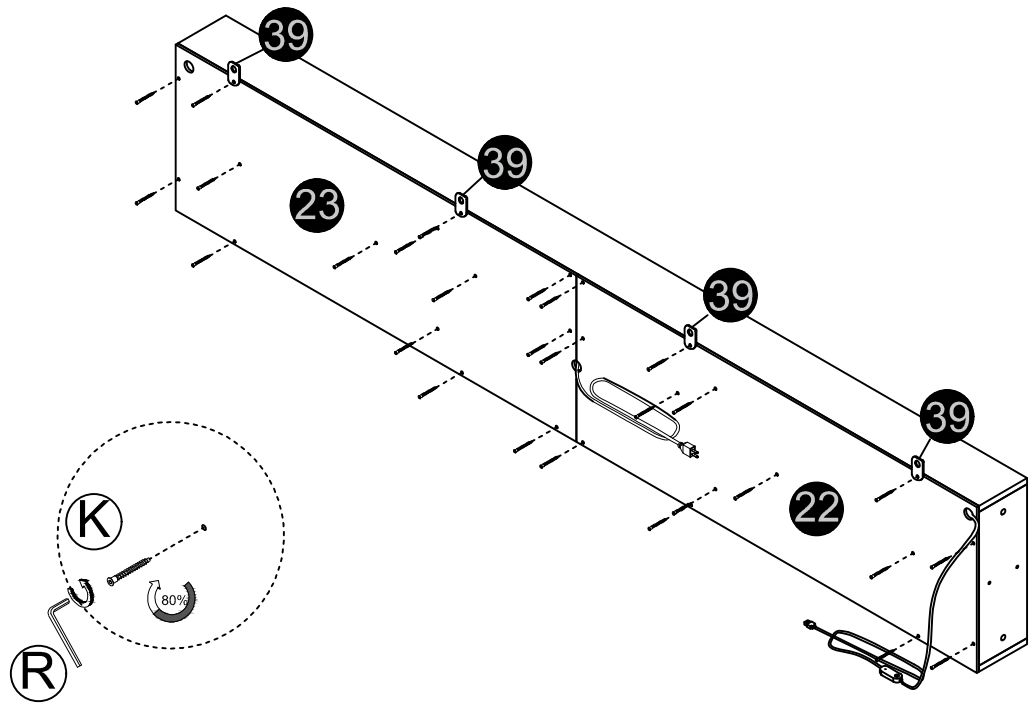

9

A*4



M8×10

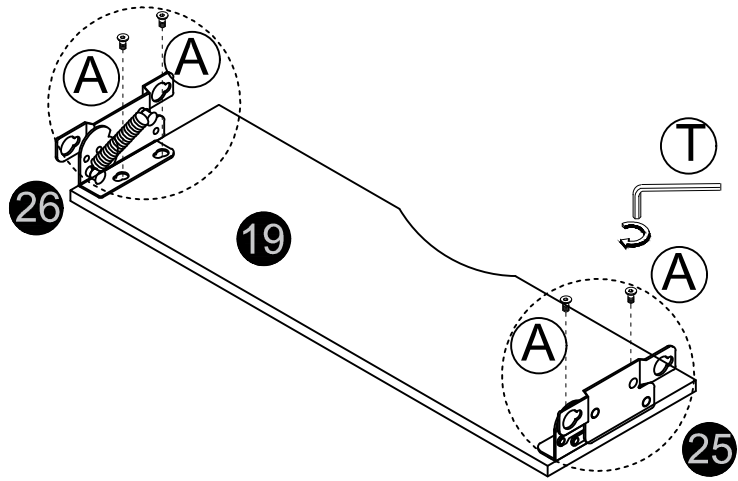

10

A*4



M8×10

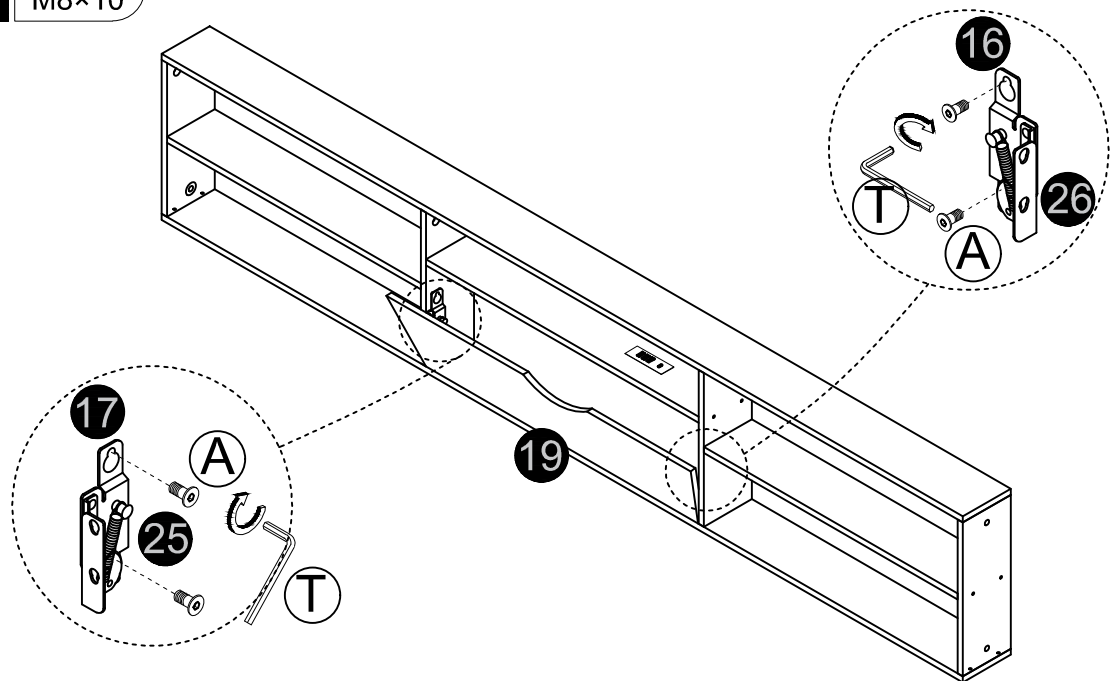

11

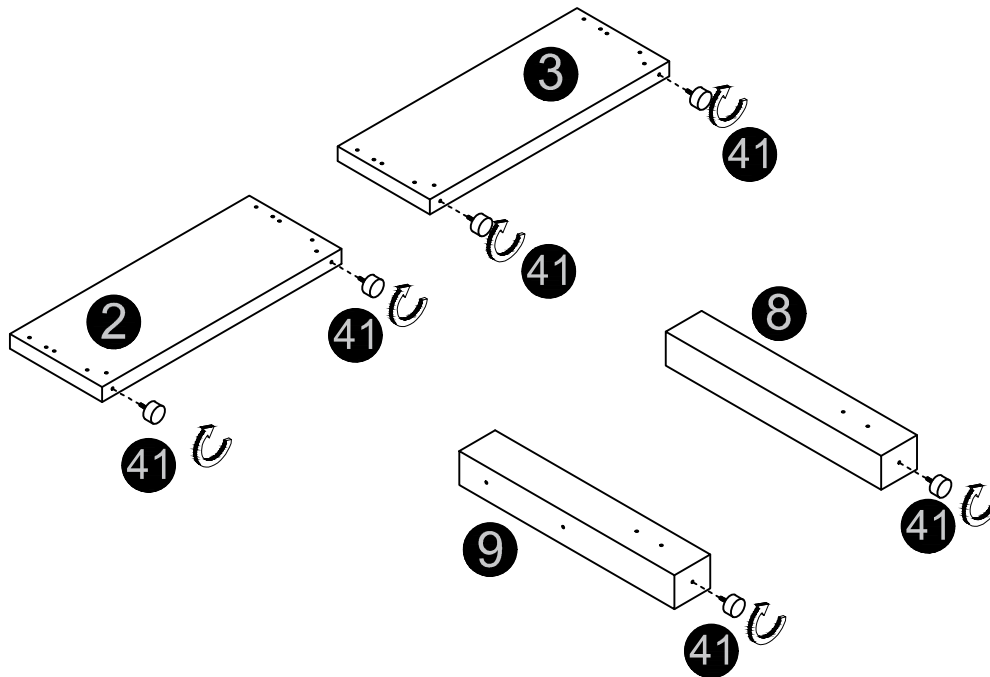

12

D*8 J*8
M8×40 Ø8×22mm

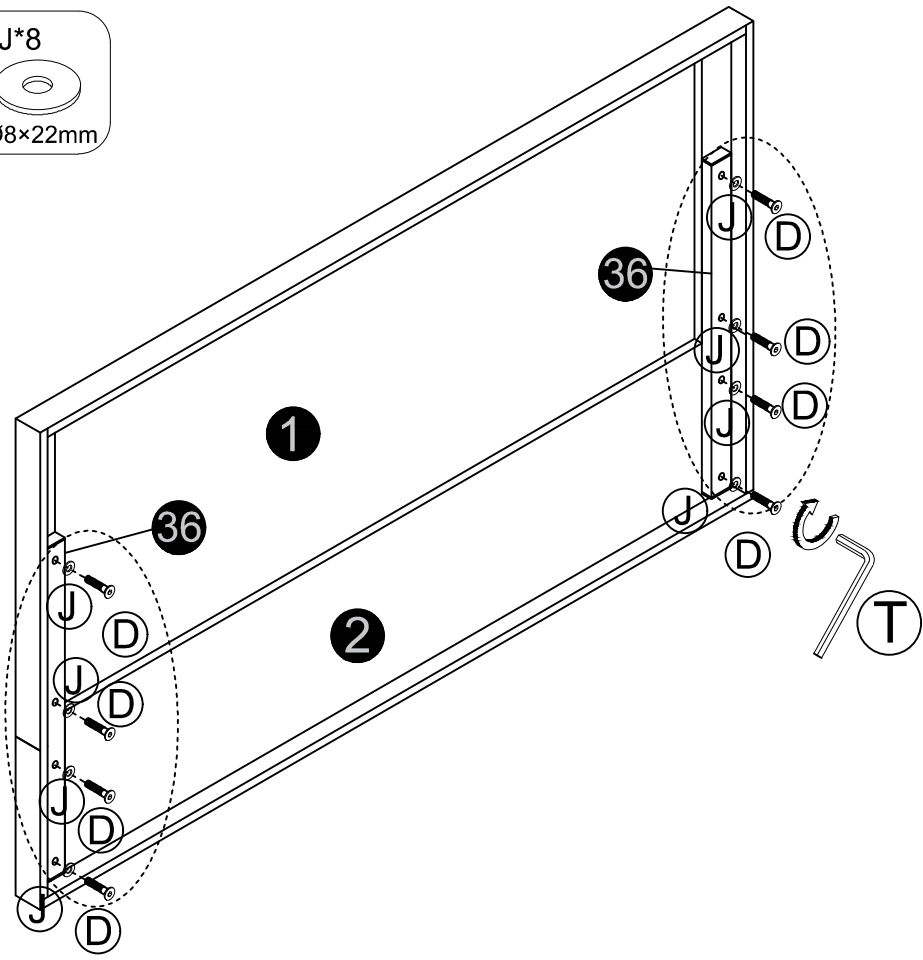

13 C*14
M8×35

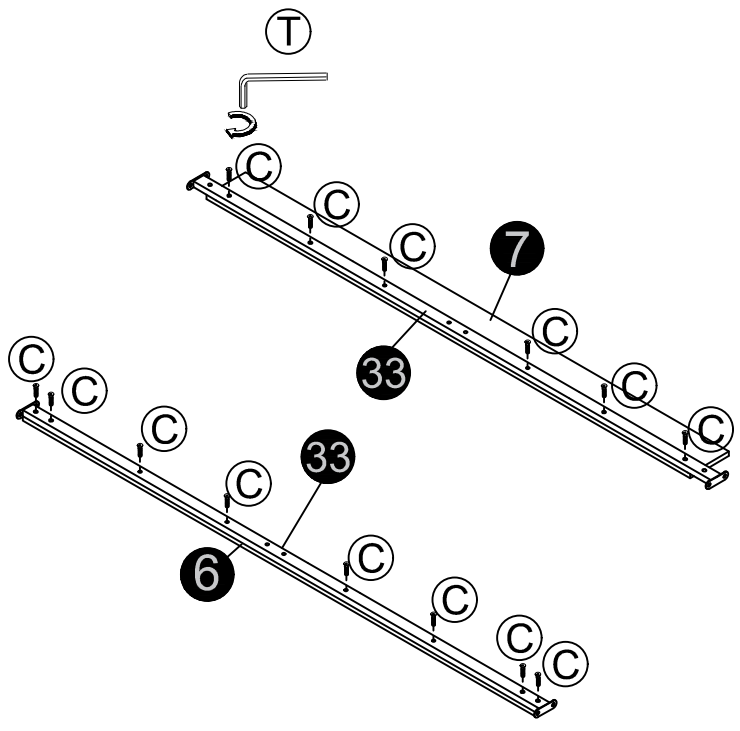

14L B*8
M8×16

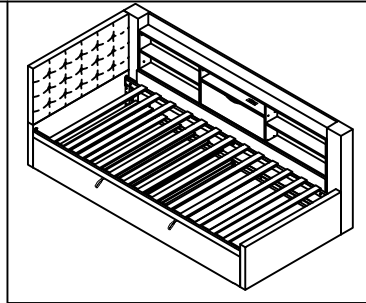
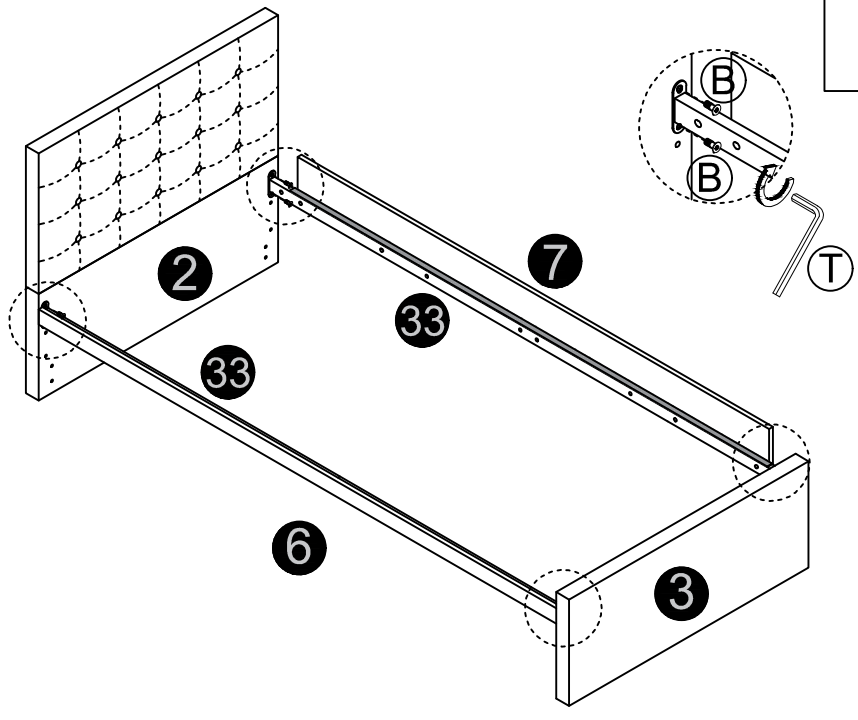

14R

B*8



M8x16

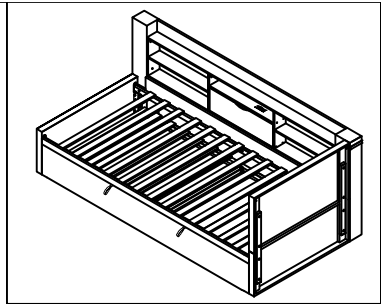
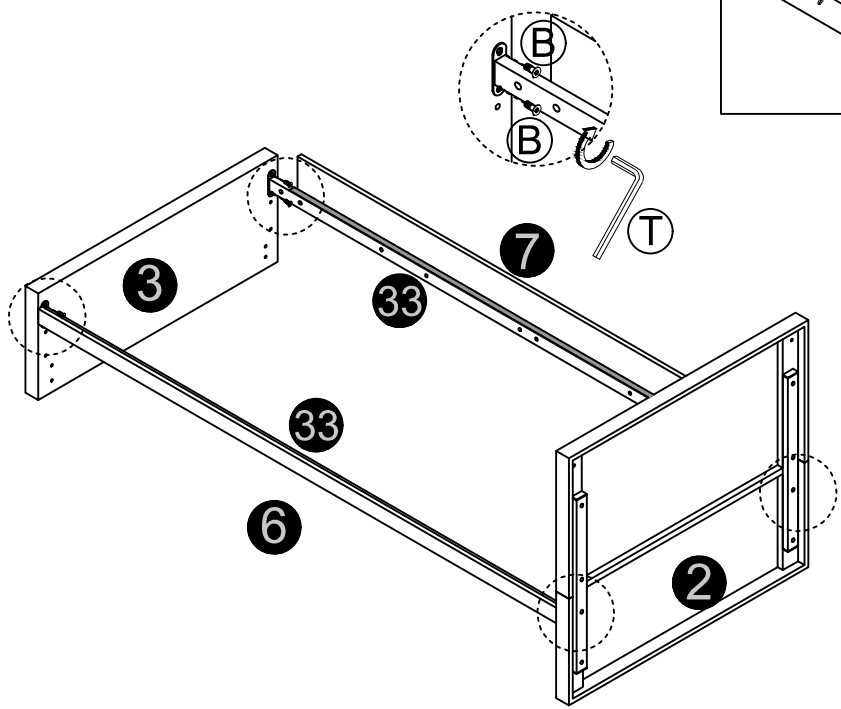

15L

B*8



M8x16

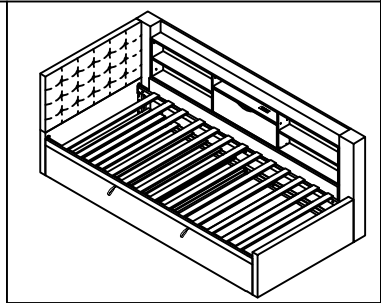
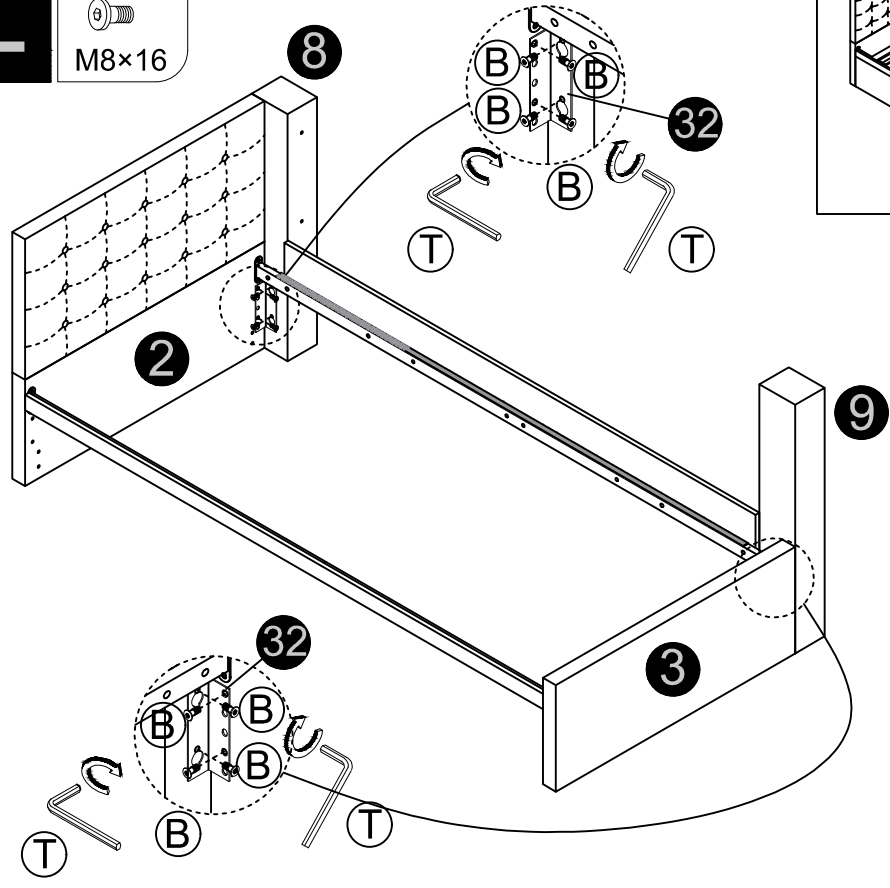

15R

B*8
M8x16

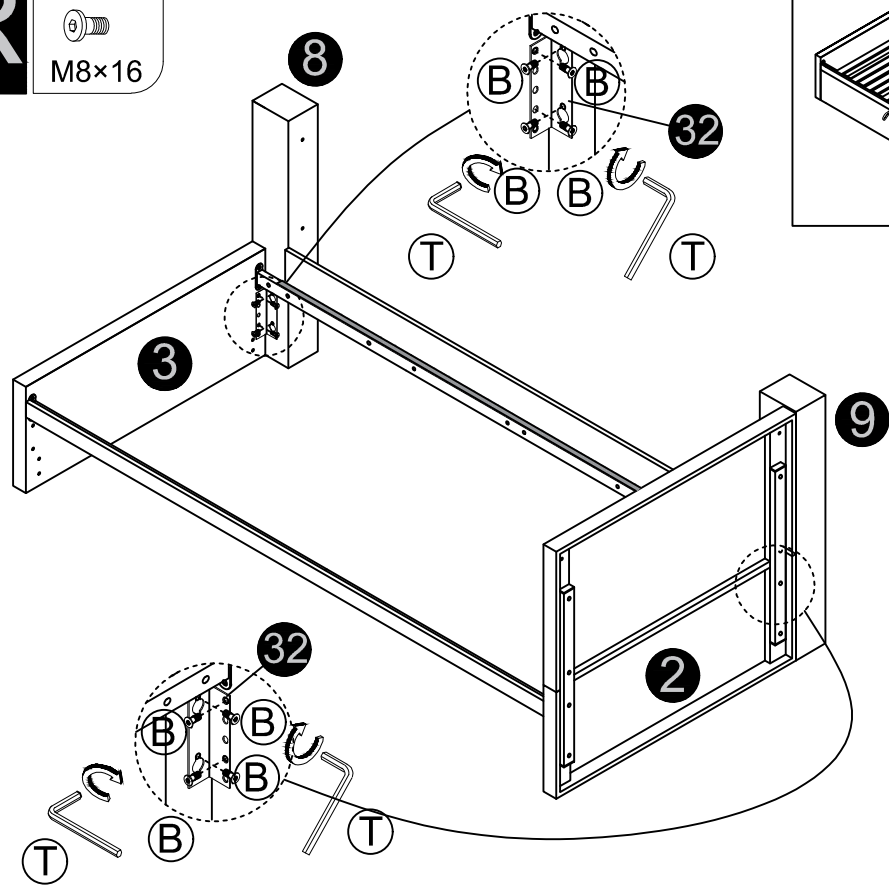

16

C*2
M8x35

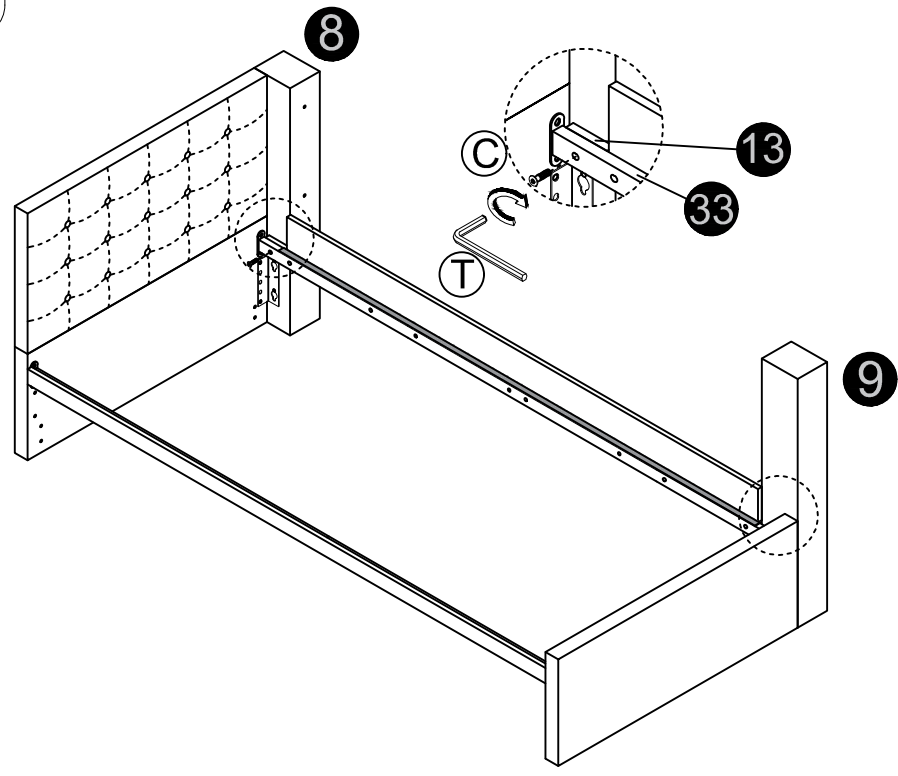

17L

B*6



M8x16

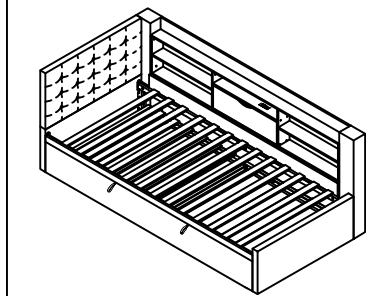
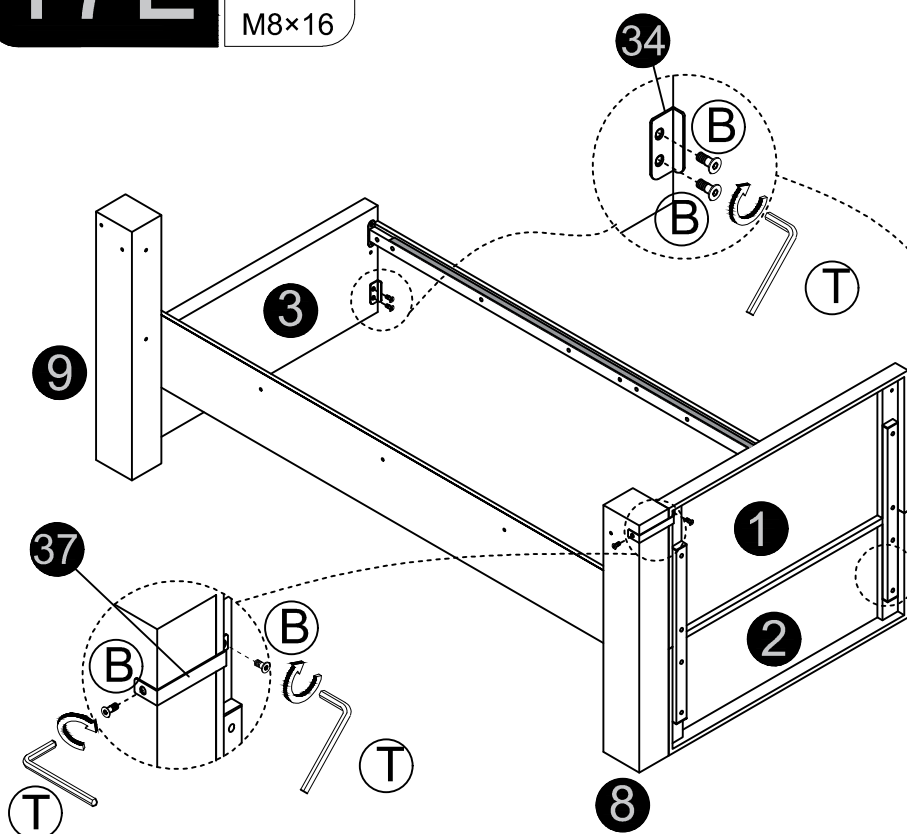

17R

B*6



M8x16

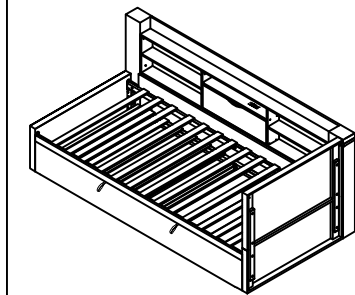
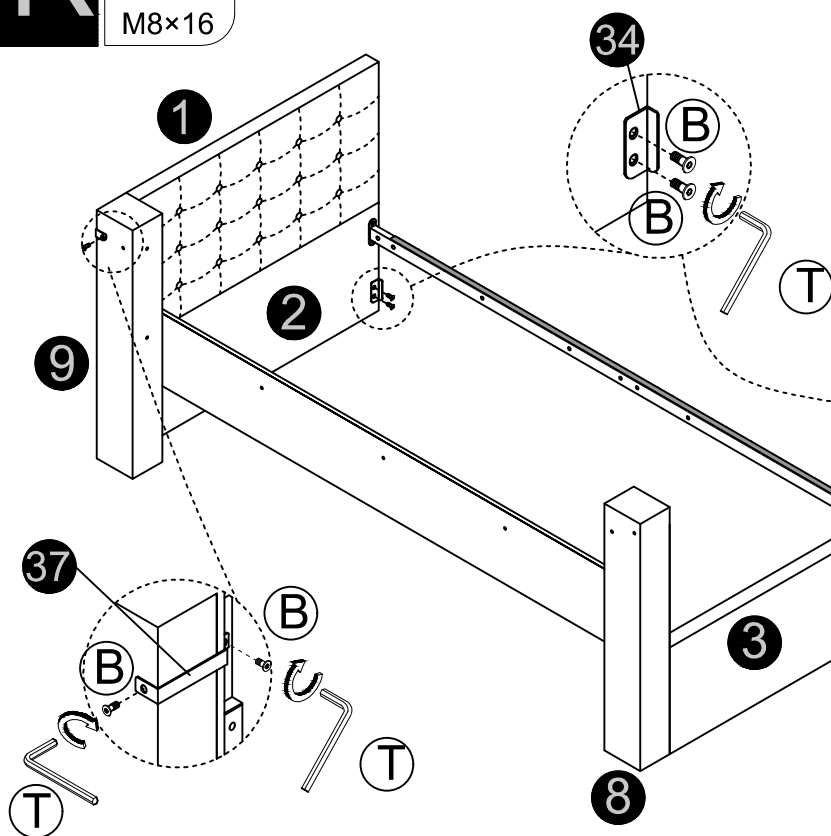

18

C*4

J*4



M8x35 Ø8x22mm

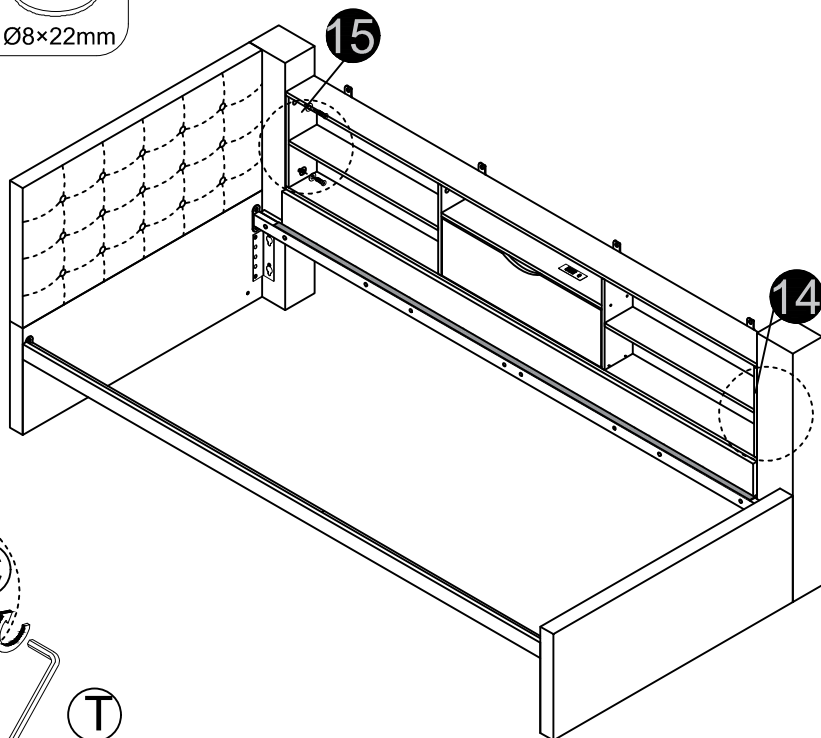

19

A*3

B*3



M8x10 M8x16

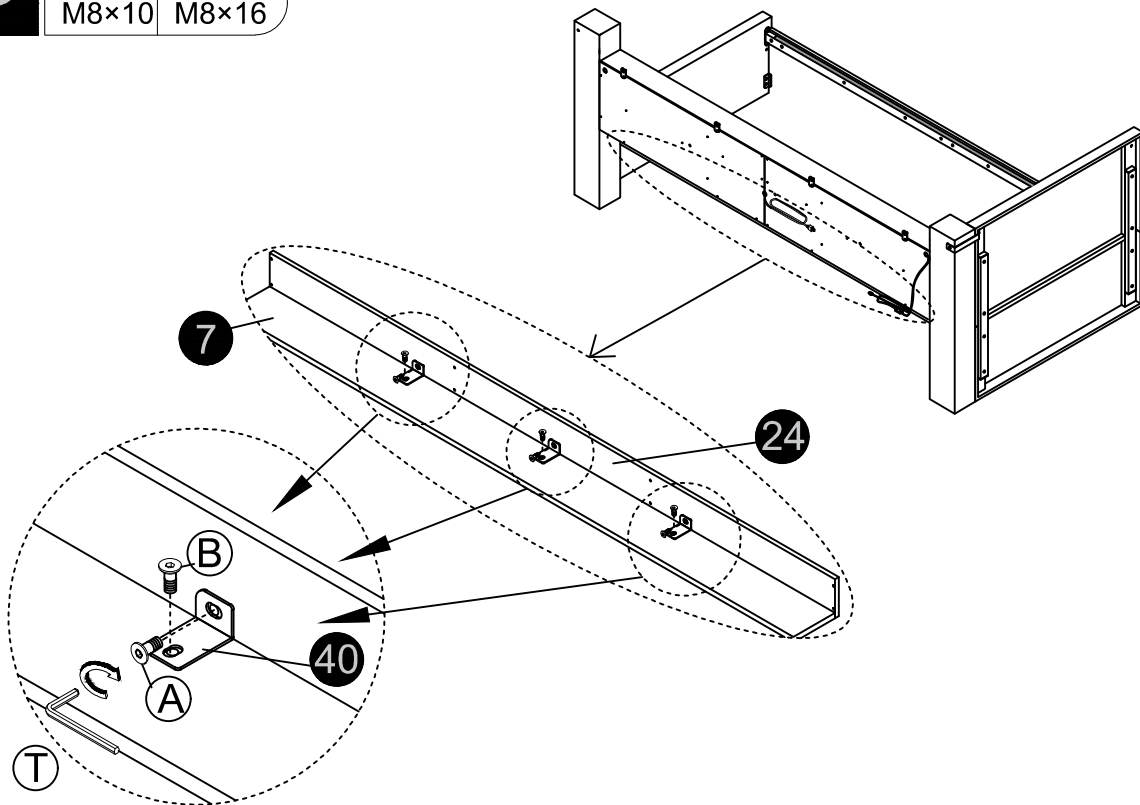

20

A*6

B*2



M8x10

M8x16

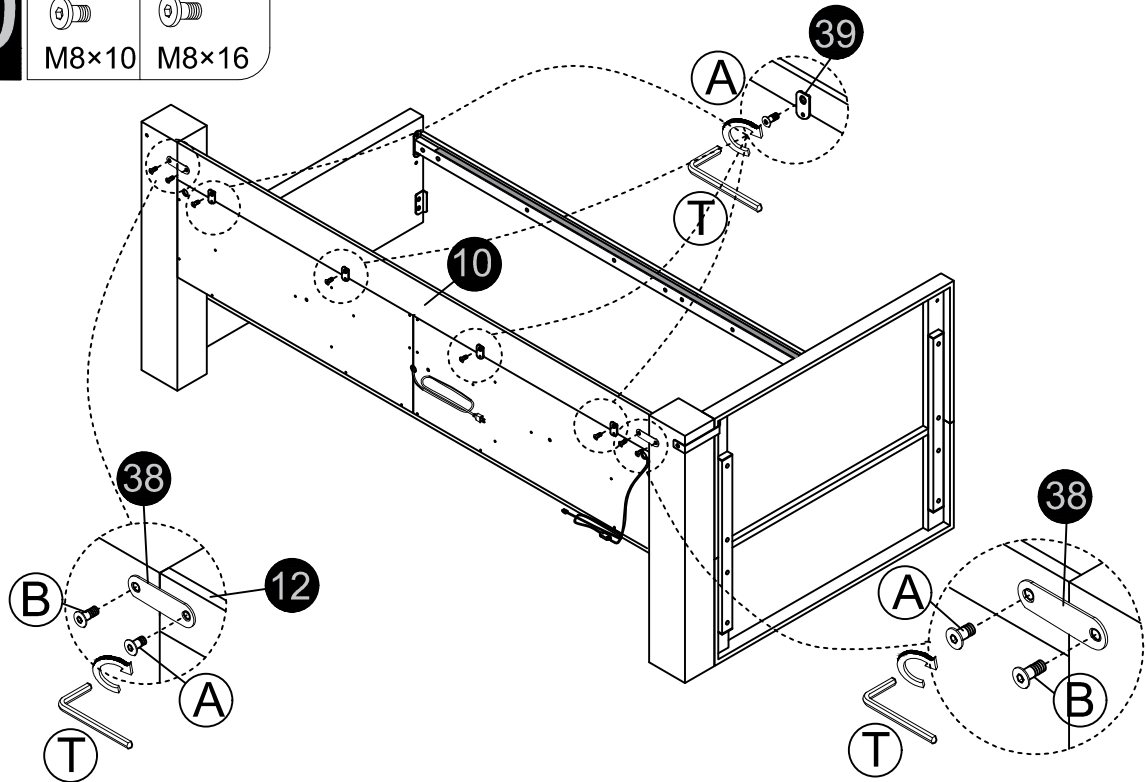

21

C*4



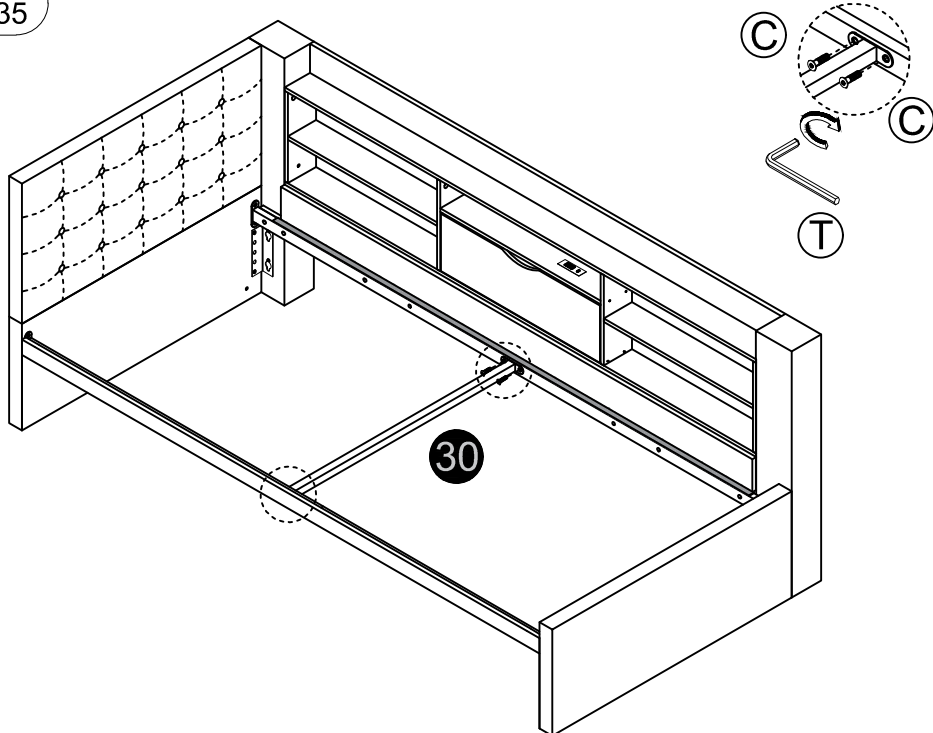

M8x35

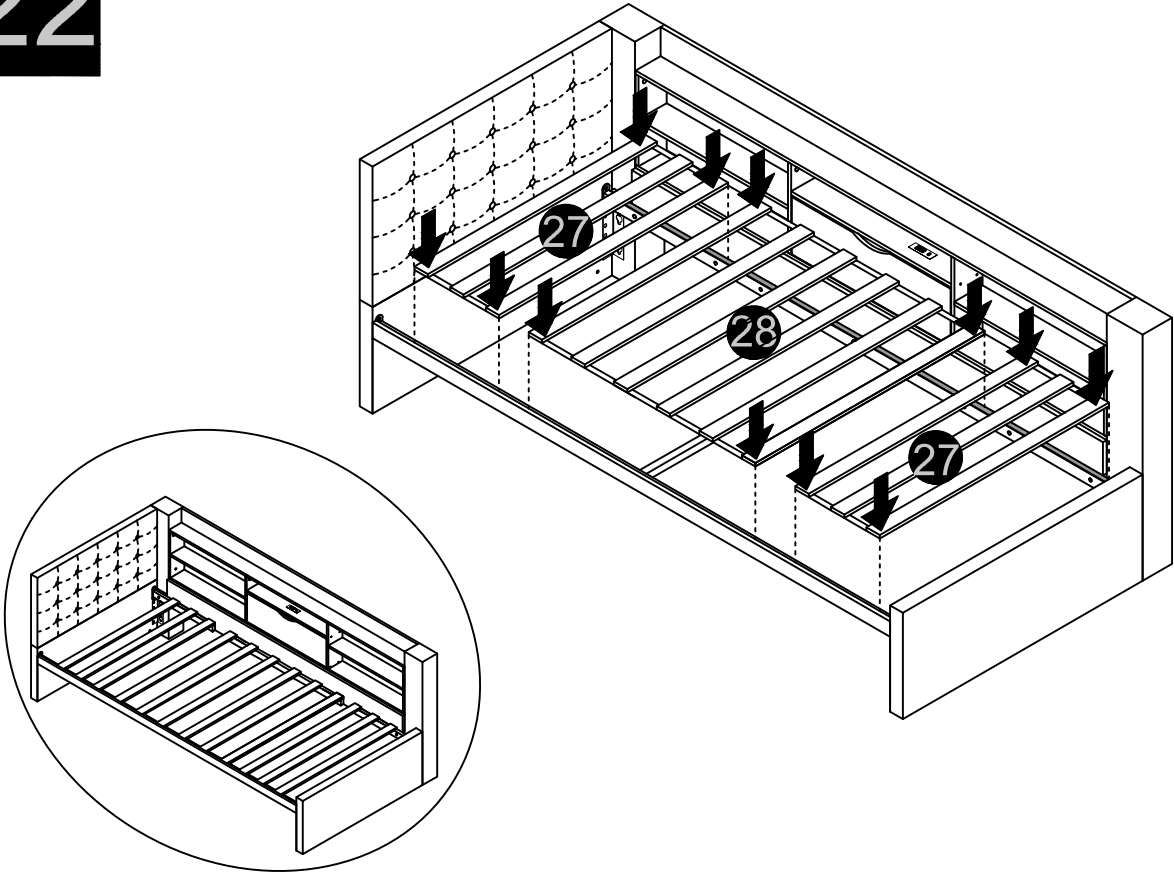

22



23

H*4	O*4
	
M6x35	M6

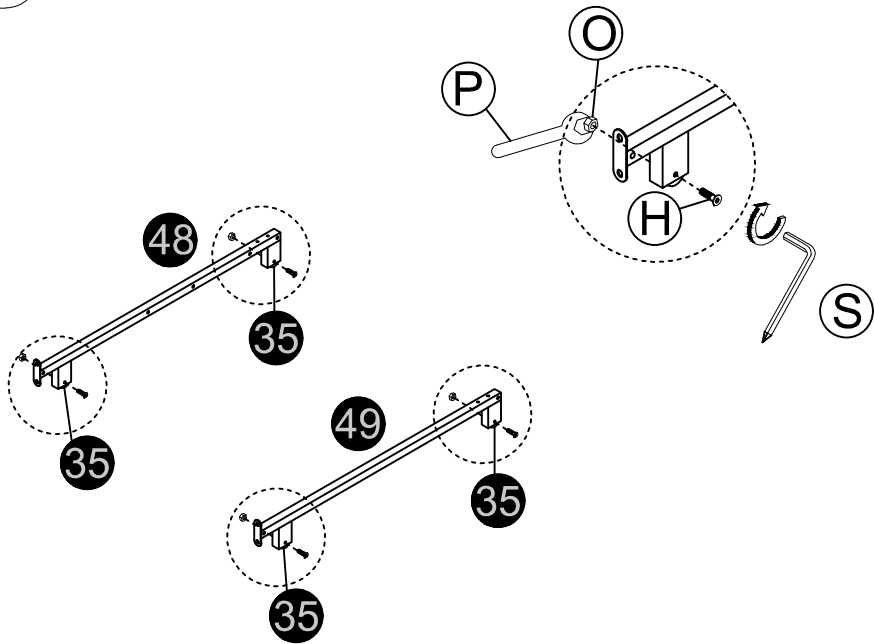

24

G*4



M6×16

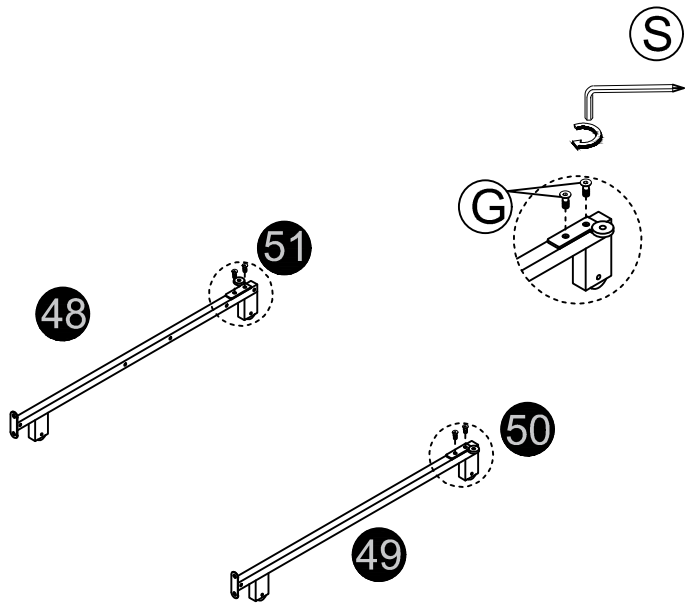

25

I*4



M6×50

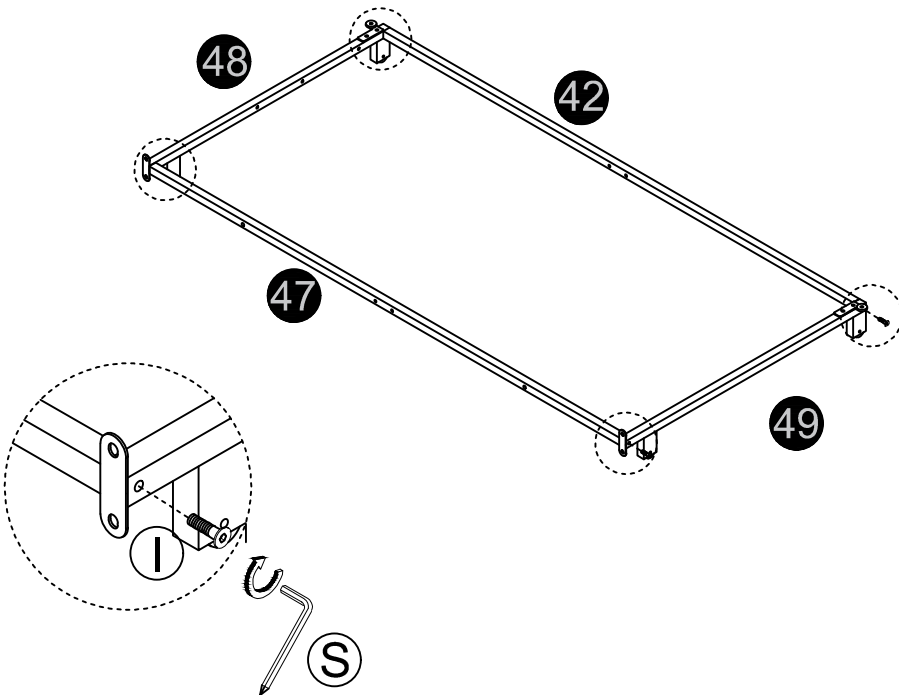

26

B*6

D*4



M8×16

M8×40

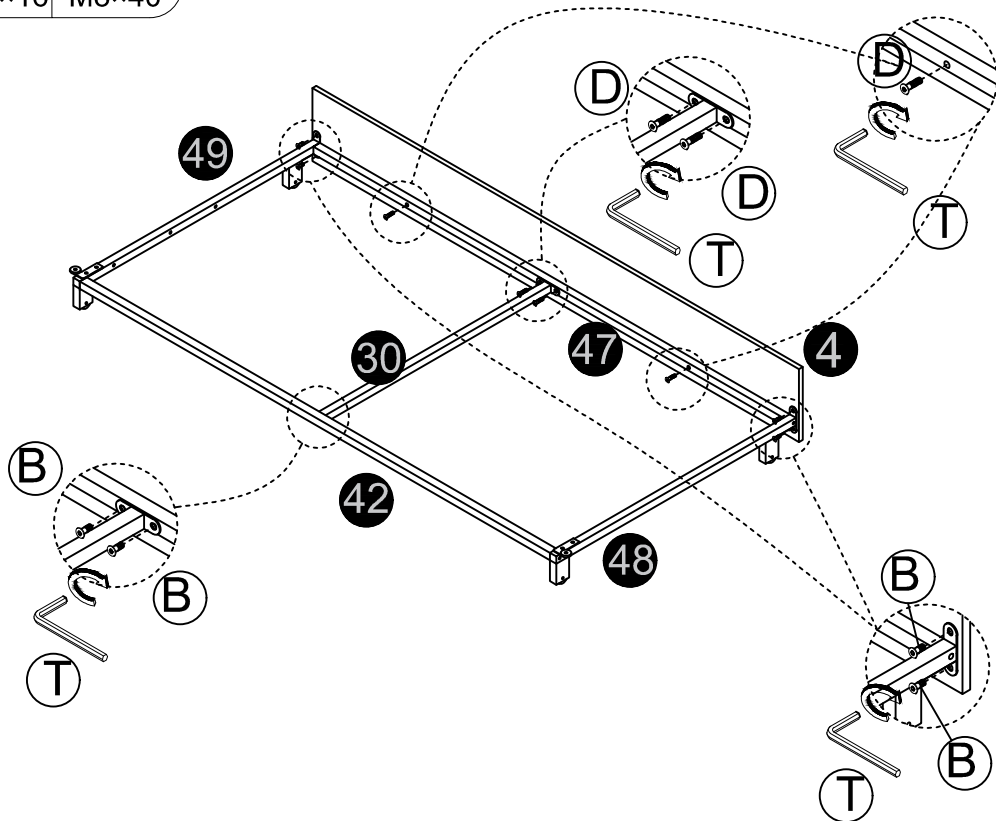

27

B*6



M8×16

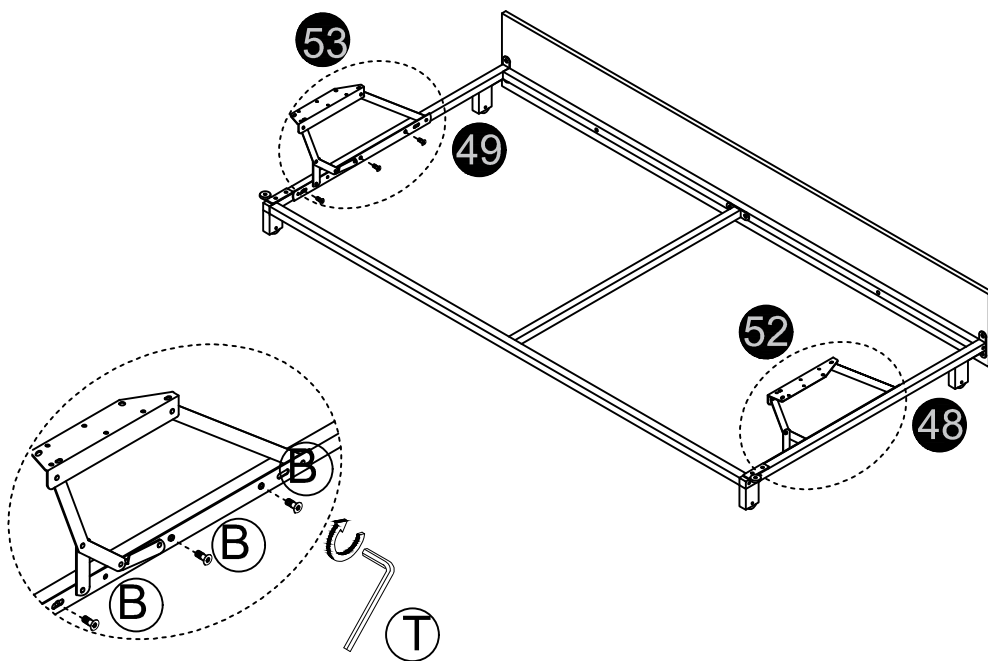

28

I*4



M6×50

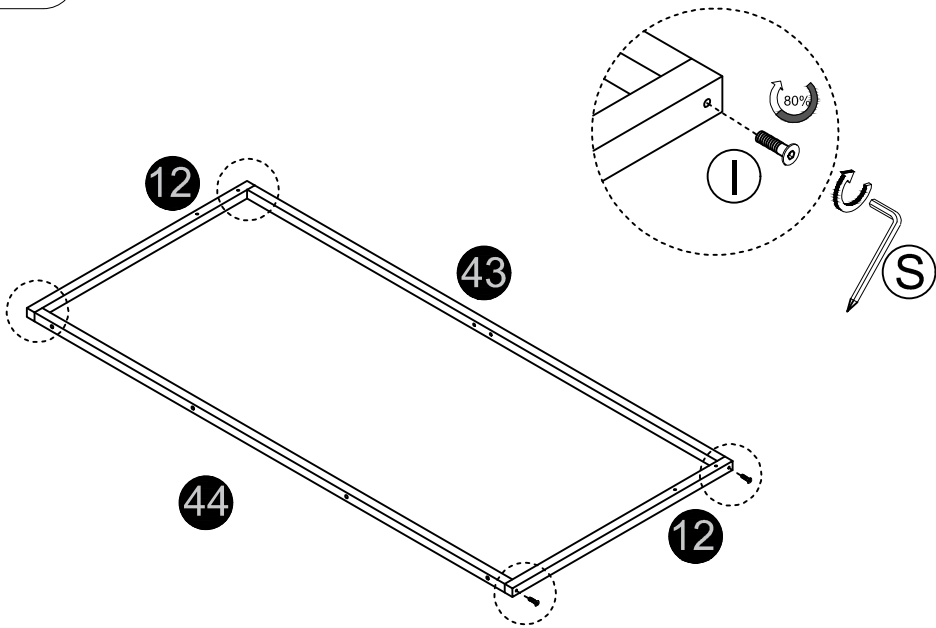

29

B*4



M8×16

E*2



M8×45

F*2



M8×50

J*2



Ø8×22mm

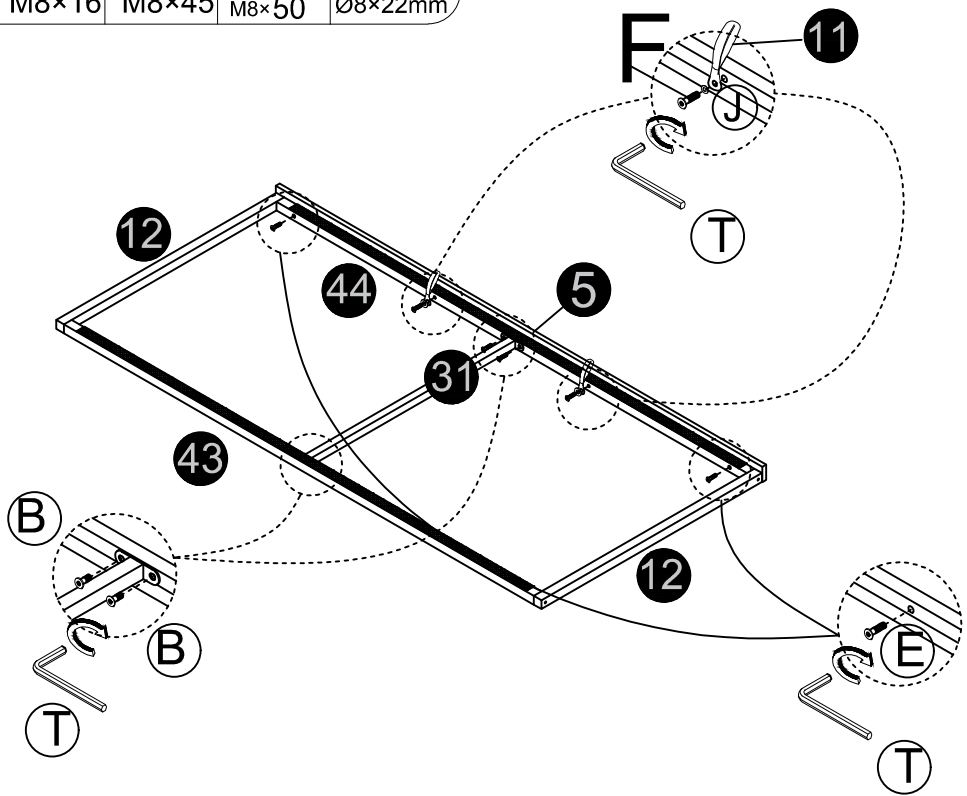

30

G*4
M6×16

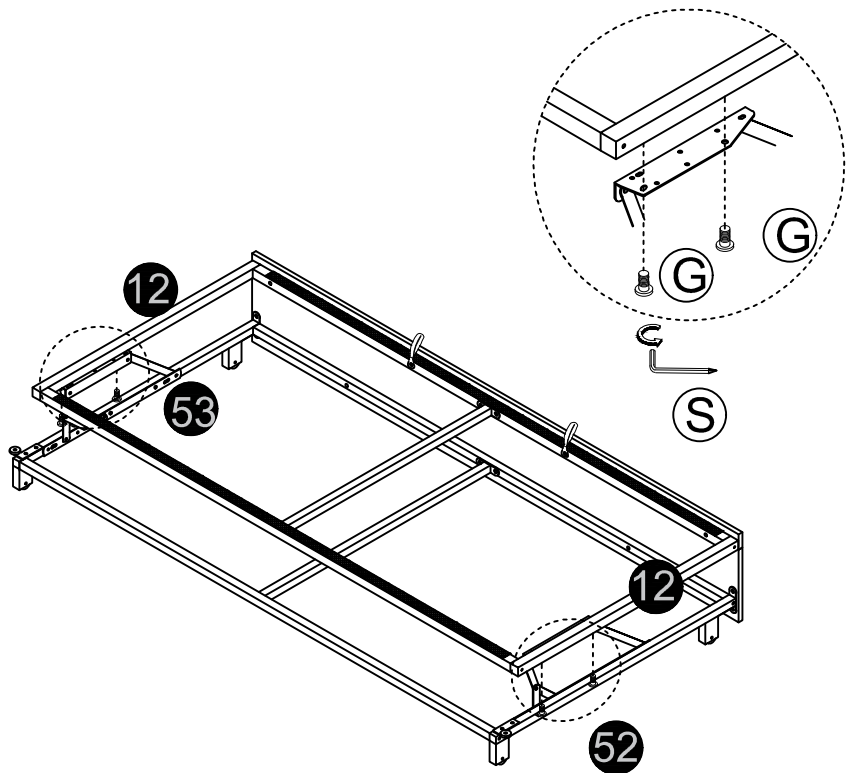

31

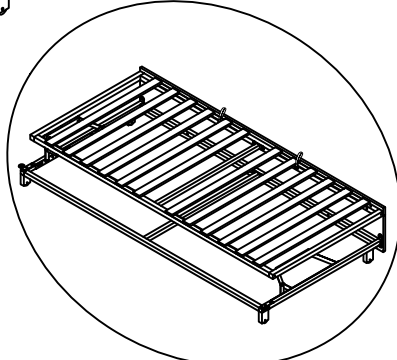
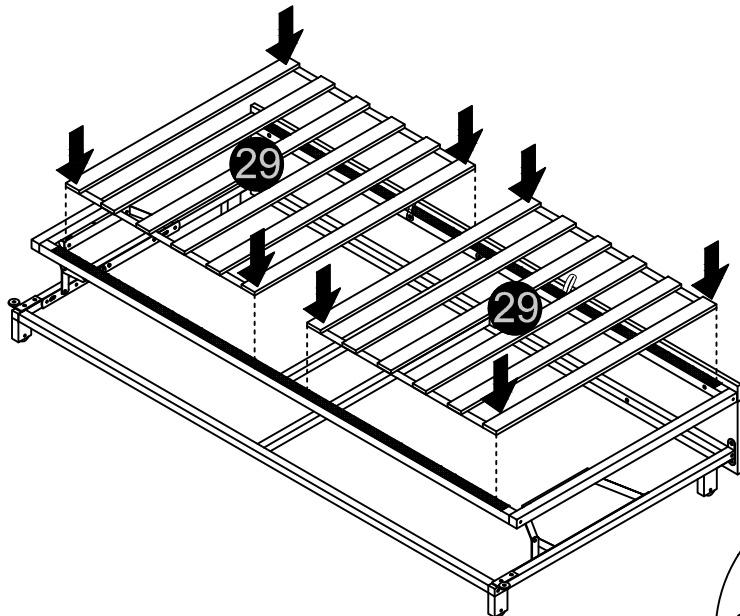

32

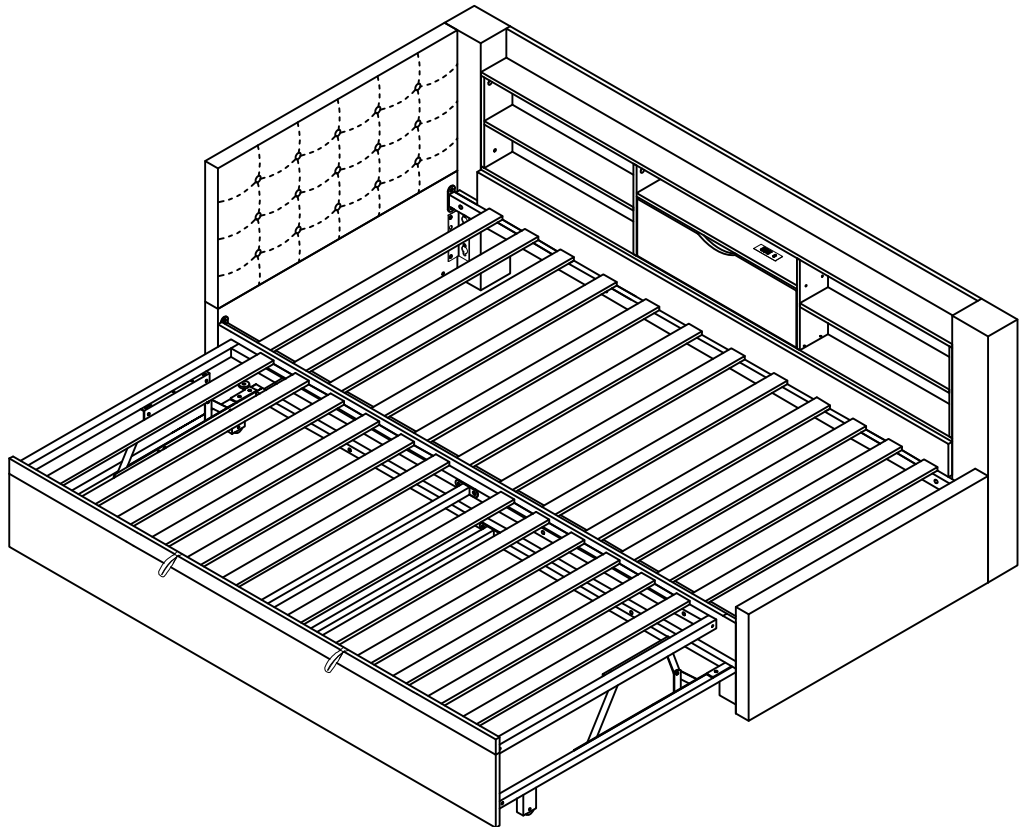

33

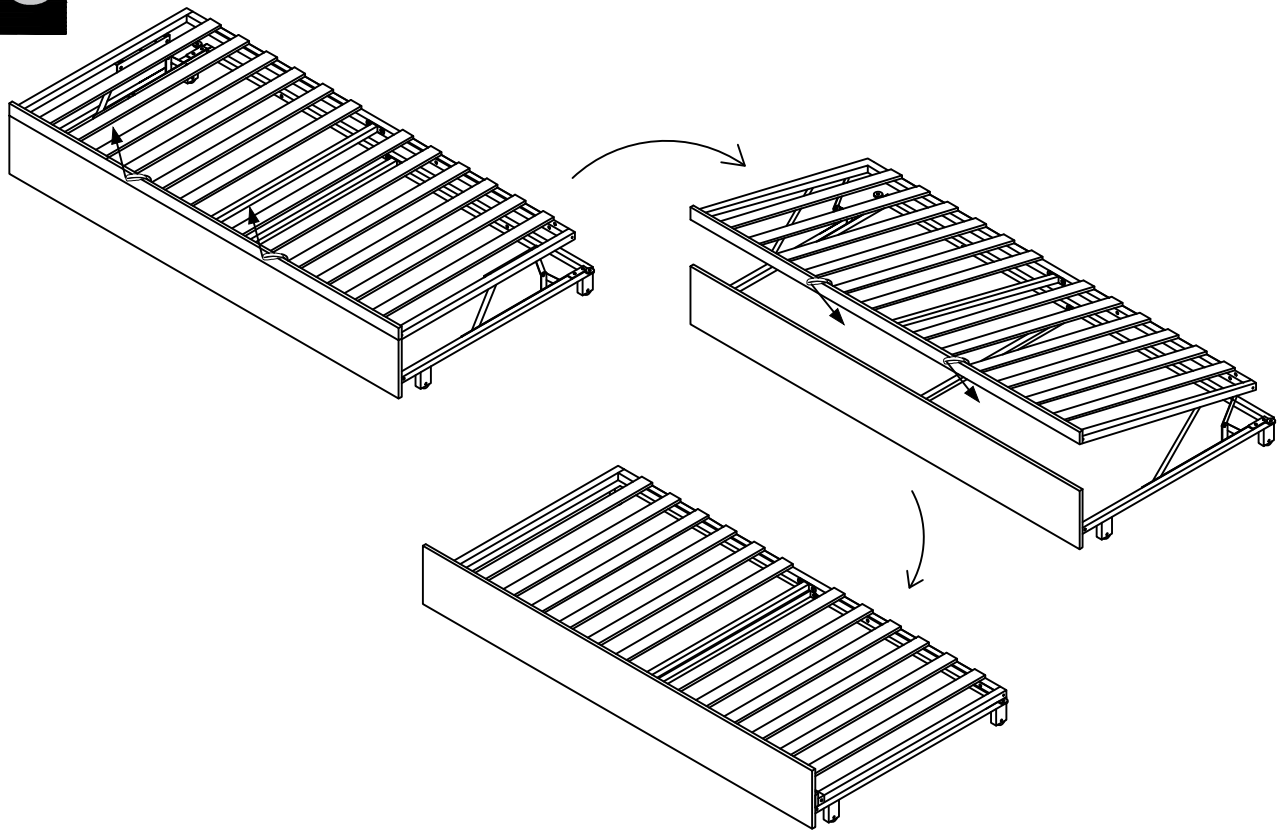

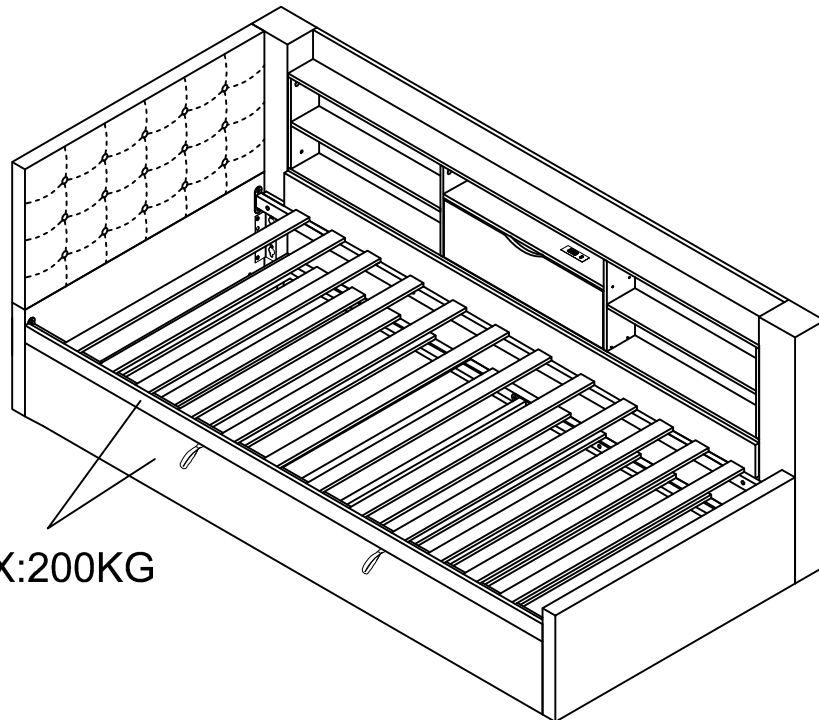

MAX:200KG

Optional: Cover screw holes with included decorative tape.

Optional: Schraublöcher mit beiliegender Dekofolie abdecken.

Optionnel : Masquez les trous de vis avec le ruban décoratif inclus.

Opzionale: Coprire i fori delle viti con il nastro decorativo incluso.

Opcional: Cubra los agujeros de tornillos con la cinta decorativa incluida.

①



②



③



④

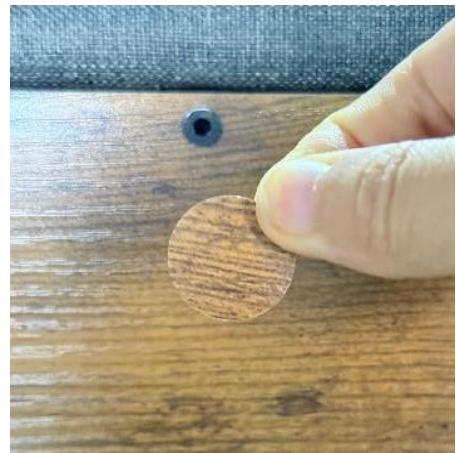

⑤



⑥



Led Bluetooth MiniController Manual

Please download "LotusLamp X" in the app store or scan the QR code below to download



1 .Download the"LotusLamp X"app with your phone by scanning theQR code or searching for the Lotus Lamp app inthe iPhone App Store or Google Play Store.

2.After the APP are downloaded successfully, you need toturn on Bluetooth function on your phone firstly, then plug inthe strip light, then open the APP, your APP will pair with thestrip light automatically and you can control it.

Unable to Connect Troubleshooting

(1)Checkifthe power supply of the light strip is normal.

(2)Check if the Bluetooth is turn on.

(3)Check if there are other mobile phone are connectedBluetooth 4.0 only support connections one to many,dose not support many to many.

(4)CheckAPP Bluetooth setting if the phone is connected tothe device,ifconnect,exit theAPPand reopen,the APPwill go to connect automatically.

(5)Normal operations and can not connect, please exit theAPP and reopen.

(6)Exit APP, restart mobile phone, power on the strip light.reopen the APP, then them will connect automatically.



KEEP new and used batteries **OUT OF REACH** of **CHILDREN**.
Seek immediate medical attention if a battery is suspected to be swallowed or inserted inside any part of the body.
If the battery compartment does not close securely, stop using the product and keep it away from children.



If a battery has been ingested, or there is a possibility one might have been ingested, please seek medical attention and inform the medical authorities that you suspect battery ingestion.

It's not always clear when a child has swallowed a button battery, as there are no specific symptoms. However, they might:

- cough, gag, or drool;
- seem to have a stomach bug or virus;
- vomit;
- complain of pain in their stomach, chest, or throat;
- appear tired or sluggish; and
- lose their appetite.

Since the signs aren't obvious, it's important to keep a close eye on loose, used, or spare button batteries in your home, as well as the products that contain them.



Certificate Of Compliance

Certificate No. : BZT252355000415EC
Applicant : Xiamen Zhenlexin Electronic Technology Co., Ltd
Address : 3rd Floor, No. 96, Huli Yuan, Xinmei Sub-district, Tong'an District, Xiamen
 City
Manufacturer : Xiamen Zhenlexin Electronic Technology Co., Ltd
Address : 3rd Floor, No. 96, Huli Yuan, Xinmei Sub-district, Tong'an District, Xiamen
 City
Product Name : Light strip
Main Model : ZLX5050RGB-30D
Series Models : ZLX5050RGB-60D (All models share same electric circuits except outer shape and model name.)

Essential requirement		Applied Specifications/Standards	Documentary Evidence	Result
Art.3.1(a)	Health	BS EN 62479:2010	BZT252355000415ER03	Pass
Art.3.1(a)	Safety	BS EN IEC 60598-1:2021+A11:2022 BS EN 60598-2-21:2015	BZT252355000415SR	Pass
Art.3.1(b)	EMC	ETSI EN 301 489-1 V2.2.3 (2019-11) ETSI EN 301 489-3 V2.3.2 (2023-01) BS EN IEC 55015:2019/A11:2020 BS EN IEC 61547:2023 BS EN IEC 61000-3-2:2019+A1:2021+A2:2024 BS EN 61000-3-3: 2013+A1:2019+A2:2021	BZT252355000415ER02	Pass
Art.3.2	Radio	ETSI EN 300 440 V2.2.1 (2018-07)	BZT252355000415ER01	Pass

Technical documentation of the company and the product above have been observed and audit has been completed successfully by us with UK Radio Equipment Regulations (SI 2017 No.1206).

The UKCA mark shown below can only be used under the responsibility of the manufacturer with the completion of UK Declaration of Conformity and other necessary technical documentation for all the relevant regulation(s). The certificate applies to the tested sample above mentioned only and shall not imply an assessment of the whole production.

Remark: This report supersedes BZT252355000415EC which is withdrawn.



Scan QR code
verification of authenticity



Alex Wu

Alex Wu
Technical director
Date: Oct.23, 2025



Lab Name : BZT Testing (Dongguan) Co.,Ltd.
Lab : 1F, Bangying Building, Fuma, Chigang Community, Humen Town, Dongguan City,
Address : Guangdong Province, China
BZT http : www.bzt-test.com
Telephone : +86-0769-81516886
 Confirm the authenticity of Test reports Email: bzt@bzt-test.com



Certificate Of Compliance

Certificate No. : BZT252355000415SC-R1
Applicant : Xiamen Zhenlexin Electronic Technology Co., Ltd
Address : 3rd Floor, No. 96, Huli Yuan, Xinmei Sub-district, Tong'an District, Xiamen City
Manufacturer : Xiamen Zhenlexin Electronic Technology Co., Ltd
Address : 3rd Floor, No. 96, Huli Yuan, Xinmei Sub-district, Tong'an District, Xiamen City
Product Name : Light strip
Main Model : ZLX5050RGB-30D
Series Models : ZLX5050RGB-60D (All models share same electric circuits except outer shape and model name.)
Trade mark : /
Test Standard : BS EN IEC 60598-1:2021+A11:2022
: BS EN 60598-2-21:2015
Report No. : BZT252355000415SR-R1

Technical documentation of the company and the product above have been observed and audit has been completed successfully by us. The Electrical Equipment (Safety) Regulations 2016 have been taken as references for these processes.

The UKCA mark shown below can only be used under the responsibility of the manufacturer with the completion of UK Declaration of Conformity and other necessary technical documentation for all the relevant regulation(s). The certificate applies to the tested sample above mentioned only and shall not imply an assessment of the whole production. It is only valid in connection with the test report number. BZT252355000415SR-R1



Scan QR code
verification of authenticity



Alex



Alex Wu
Technical Director
Date: Oct. 23, 2025

Lab Name : BZT Testing (Dongguan) Co., Ltd.
Lab Address : 1F, Bangying Building, Fuma, Chigang Community, Humen Town Dongguan, GUA, 523900, China
Website : www.bzt-test.com **Telephone** : +86-0769-81516886
Confirm the authenticity of Test reports Email: bzt@bzt-test.com



Certificate Of Compliance

Certificate No. : BZT252355000417CC-R1
Applicant : Xiamen Zhenlexin Electronic Technology Co., Ltd
Address : 3rd Floor, No. 96, Huli Yuan, Xinmei Sub-district, Tong'an District, Xiamen City
Manufacturer : Xiamen Zhenlexin Electronic Technology Co., Ltd
Address : 3rd Floor, No. 96, Huli Yuan, Xinmei Sub-district, Tong'an District, Xiamen City
Sample Name : Light strip
Main Model : ZLX5050RGB-30D
Additional Model : ZLX5050RGB-60D
BS EN 62321-1:2013
BS EN 62321-2:2021
BS EN 62321-3-1:2013
BS EN 62321-4:2013/AMD1:2017
Test Standard : BS EN 62321-5:2013
BS EN 62321-6:2015
BS EN 62321-7-1:2015
BS EN 62321-7-2:2017
BS EN 62321-8:2017
As shown in the Test Report No. : BZT252355000417CR-R1

The EUT described above has been consolidated by us and found in compliance with the council of UK RoHS Restriction of Use of Certain Hazardous Substances in Electrical and Electronic Equipment Regulations SI 2012/3032. The certificate applies to the tested sample above mentioned only and shall not imply an assessment of the whole production. It is only valid in connection with the test report Number BZT252355000417CR-R1.



Scan QR code
verification of authenticity

**UK
CA** **RoHS**

Mark Wen



Mark Wen
Technical director
Date: Oct.28,2025

Lab Name : BZT Testing (Dongguan) Co., Ltd.
Lab : 1F, Banging building, Fuma, Chigang community, Humen Town, Dongguan City,
Address : Guangdong Province, China
BZT http : www.bzt-test.com **Telephone** : +86-0769-81516886
Confirm the authenticity of Test reports Email: bzt@bzt-test.com



CERTIFICATE OF CONFORMITY

Electromagnetic Compatibility Regulations 2016 (SI 2016 No. 1091)

This Certificate of Conformity is hereby issued to the product designated below:

Certificate No...... : 25EP06144E02
Report No...... : EP2506144E02
Date Issue. : 2025-07-07
Applicant's name : Zhangzhou Jinhe Electronic Technology Co., Ltd
Address : 2nd Floor, Building 2, No.15 Jinxia Road, Wenpu Industrial Park,
JiaomeiTown, Zhangzhou City, Fujian Province,China
Manufacturer's name : Zhangzhou Jinhe Electronic Technology Co., Ltd
Address : 2nd Floor, Building 2, No.15 Jinxia Road, Wenpu Industrial Park,
JiaomeiTown, Zhangzhou City, Fujian Province,China
Product Description..... : Power Supply
Model(s)/Type References : JH-14Y
Parameters..... : See appendix for details
Standard(s) : BS EN 55032:2015+A11:2020+A1:2020
BS EN 55035:2017+A11:2020
BS EN IEC 61000-3-2:2019+A1:2021+A2:2024
BS EN 61000-3-3:2013+A1:2019+A2:2021

On the basis of the referenced test report(s), sample(s) tested of the above product have been found to comply with the standards harmonized with the directives listed on this verification at the time the tests were carried out. Other standards and Directives may be relevant to the product. This verification is part of the full test report(s) and should be read in conjunction with it(them).

Once compliance with all product relevant UKCA mark directives are verified, including any relevant e.g. risk assessment and production control, the manufacturer may indicate compliance by signing a Declaration of Conformity themselves and applying the mark to products identical to the tested sample(s).

Approved By

Eric Liu
Director of Engineering department





CERTIFICATE OF CONFORMITY

Electrical Equipment (Safety) Regulation 2016

This Certificate of Conformity is hereby issued to the product designated below:

Certificate No. : 25SP06144L02
Report No. : SP2506144L02
Date Issue. : 2025-07-04
Applicant's name : Zhangzhou Jinhe Electronic Technology Co., Ltd
Address : 2nd Floor, Building 2, No.15 Jinxia Road, Wenpu Industrial Park,
JiaomeiTown, Zhangzhou City, Fujian Province,China
Manufacturer's name : Zhangzhou Jinhe Electronic Technology Co., Ltd
Address : 2nd Floor, Building 2, No.15 Jinxia Road, Wenpu Industrial Park,
JiaomeiTown, Zhangzhou City, Fujian Province,China
Product Description : Power Supply
Model(s)/Type References : JH-14Y
Parameters : See appendix for details
Standard(s) : BS EN IEC 62368-1:2020+A11:2020

On the basis of the referenced test report(s), sample(s) tested of the above product have been found to comply with the standards harmonized with the directives listed on this verification at the time the tests were carried out. Other standards and Directives may be relevant to the product. This verification is part of the full test report(s) and should be read in conjunction with it(them).

Once compliance with all product relevant UKCA mark directives are verified, including any relevant e.g. risk assessment and production control, the manufacturer may indicate compliance by signing a Declaration of Conformity themselves and applying the mark to products identical to the tested sample(s).

Approved By

.....
Eric Liu
Director of engineering department



Certificate No. : HUAX260104705KC



Certificate of Conformity

Certificate's Holder : Zhangzhou Jinhe Electronic Technology Co., Ltd
Address : iao Mei Zhen Hong Jian Cun Jiao Song, Taiwan Merchants
 : Investment Zone, Zhangzhou, Fujian Province 3rd Floor,
 Building C, No. 59 Road

Manufacturer : Zhangzhou Jinhe Electronic Technology Co., Ltd
Address : iao Mei Zhen Hong Jian Cun Jiao Song, Taiwan Merchants
 : Investment Zone, Zhangzhou, Fujian Province 3rd Floor,
 Building C, No. 59 Road

Product Name : Embedded socket

Product Model (S) : JH-15, JH-51, JH-52, JH-53, JH-54, JH-55, JH-56, JH-57,
 : JH-58, JH-59, JH-60, JH-14Y, JH-14

Trade Mark : N/A

Related Standard(s) : IEC 62321-3-1:2013, IEC 62321-5:2013,
 IEC 62321-4:2017, IEC 62321-7-1:2015,
 IEC 62321-7-2:2017, IEC 62321-6:2015 ,
 IEC 62321-8:2017

Report No. : HUAX260104705KR

The product described above has been consolidated by us and found in compliance with the council RoHS 2.0 Directive (EU) 2015/863 and (EU)2017/2102 amending Annex II to Directive 2011/65/EU It is only valid in connection with the test report



Shenzhen Huaxiang Testing Co., Ltd
 1st Floor, Building A1, No. 2082 Jincheng Road, Shajing
 Street, Bao'an District, Shenzhen City, Guangdong Province,
 China Web.: Http:// www.hua-x.com
 E-mail: huaxiang@hua-x.com Tel.: +86-0755-23010432

