

ASSEMBLY INSTRUCTIONS

DINING TABLE

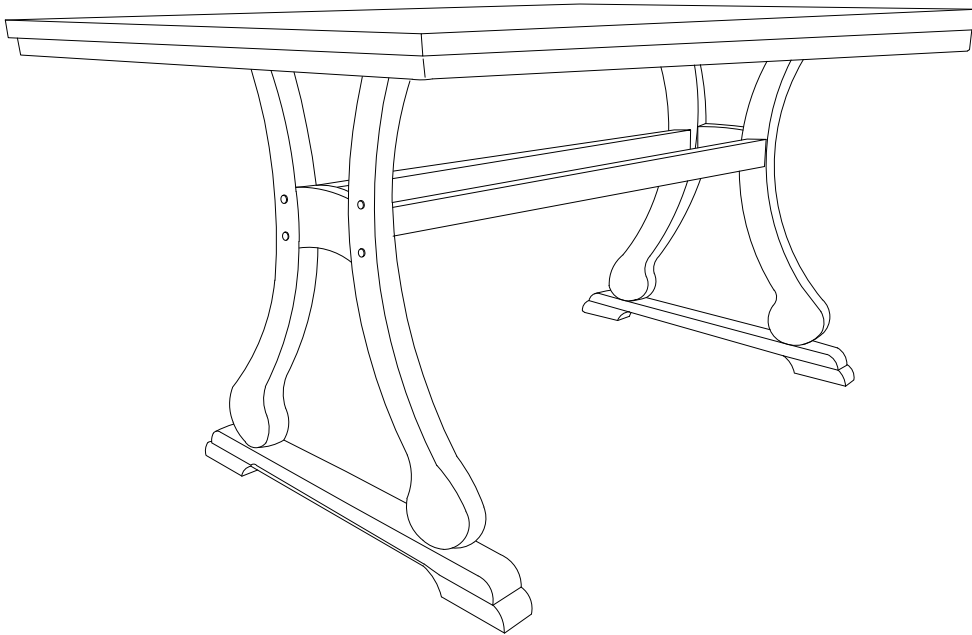

IMPORTANT NOTE:

- PLACE ALL PARTS ON A CLEAN AND SMOOTH SURFACE SUCH AS A RUG OR CARPET TO AVOID THE PARTS FROM BEING SCRATCHED.
- BEFORE YOU BEGIN, KINDLY FOLLOW THE ASSEMBLY INSTRUCTIONS STEP BY STEP.
- DO NOT TIGHTEN ALL SCREWS AND BOLTS UNTIL THE TABLE IS FULLY SET-UP.

CARTON CONTENT:

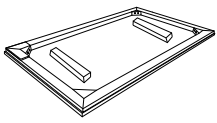

1 x 1



2 x 2

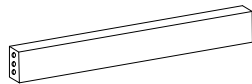

3 x 2

TABLE PART LISTS

TABLE HARDWARE LISTS

| NO. | DESCRIPTION | SKETCH | QTY |
|-----|-------------|--------|-------|
| 1 | TABLE TOP | | 1 PC |
| 2 | TABLE LEG | | 2 PCS |
| 3 | RAIL | | 2 PCS |

| NO. | DESCRIPTION | SKETCH | QTY |
|--------------|-------------------------|--------|--------------|
| A | JCBC BOLT M6 X 60 mm | | 8 PCS |
| B | CSK SCREW M4 X 38 mm | | 8 PCS |
| C | SPRING WASHER M6 | | 8 PCS |
| D | DOWEL M8 X 35 mm | | 4 PCS |
| E | WOOD BUTTON M14.5 | | 8 PCS |
| F | ALLEN KEY M4 | | 1 PC |
| SCREW DRIVER | | | NOT INCLUDED |
| HAMMER | | | NOT INCLUDED |

STEP 1

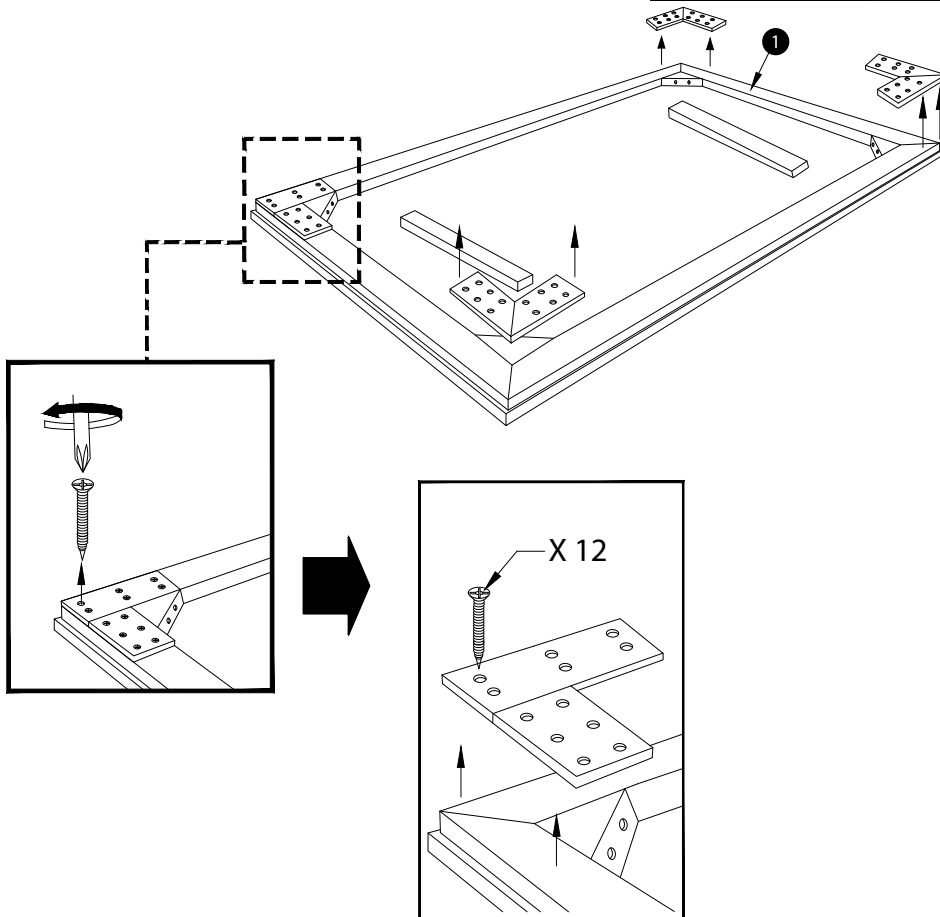

STEP 2

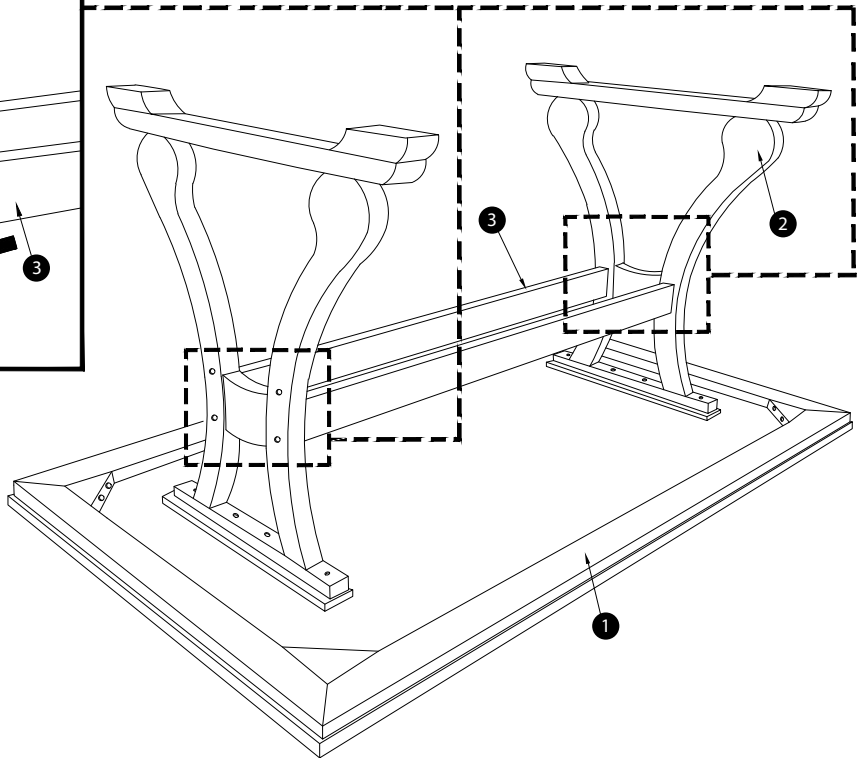
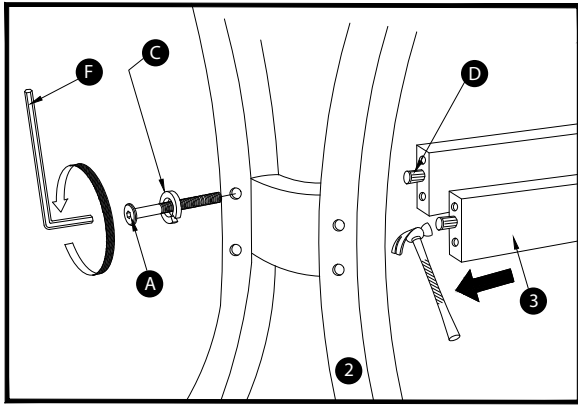

STEP 3

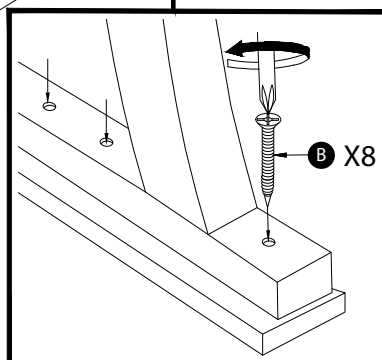
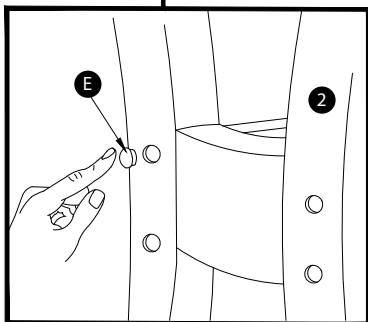
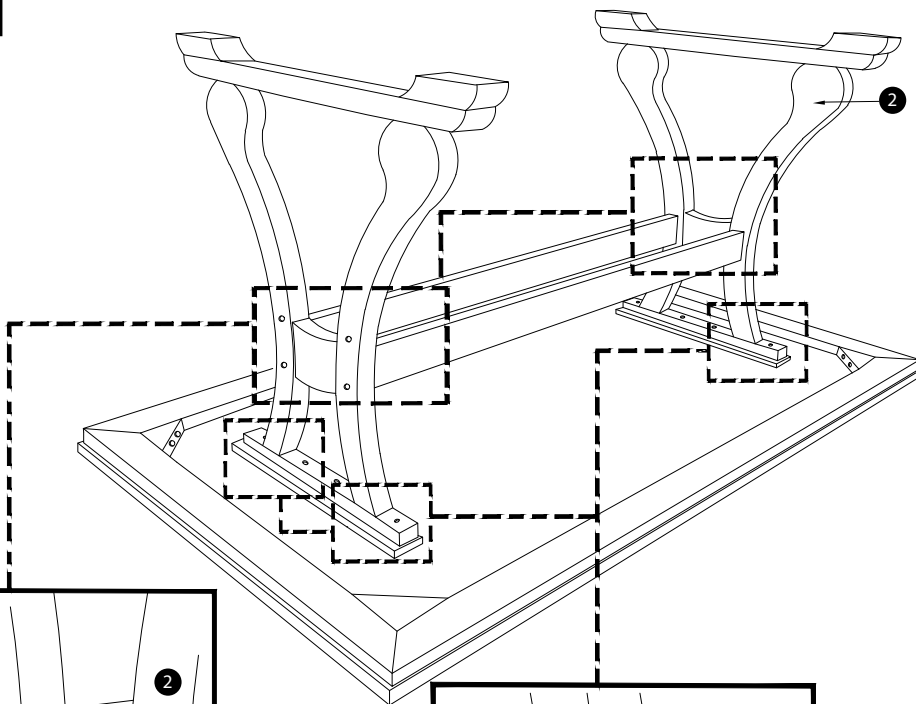

ASSEMBLY COMPLETE !

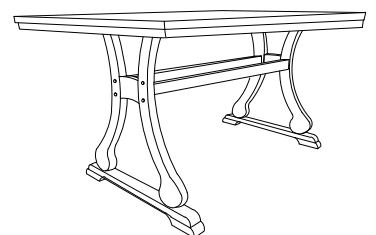

ASSEMBLY INSTRUCTIONS

DINING CHAIR

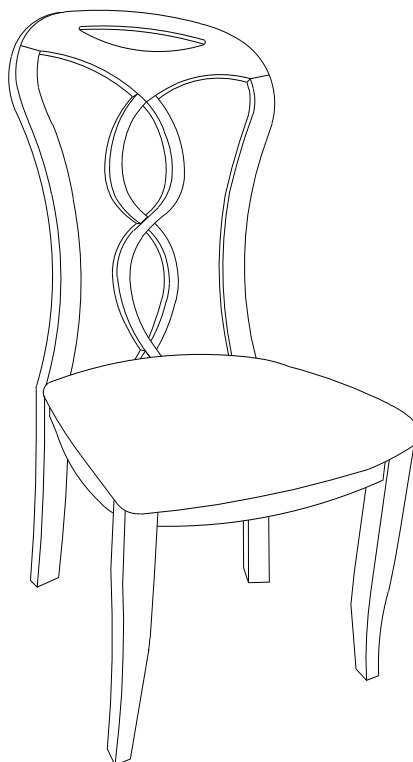

IMPORTANT NOTE:

- PLACE ALL PARTS ON A CLEAN AND SMOOTH SURFACE SUCH AS A RUG OR CARPET TO AVOID THE PARTS FROM BEING SCRATCHED.
- BEFORE YOU BEGIN, KINDLY FOLLOW THE ASSEMBLY INSTRUCTIONS STEP BY STEP.
- DO NOT TIGHTEN ALL SCREWS AND BOLTS UNTIL THE CHAIR IS FULLY SET-UP.

CARTON CONTENT:

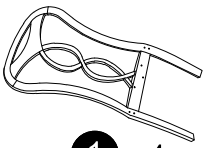

1 x 4

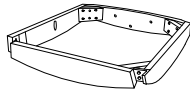

2 x 4



3 x 4



4 x 4



5 x 4

CHAIR PART LISTS

CHAIR HARDWARE LISTS

| NO. | DESCRIPTION | SKETCH | QTY |
|-----|---------------|--------|-------|
| 1 | CHAIR BACK | | 4 PCS |
| 2 | BOX SEAT | | 4 PCS |
| 3 | FRONT LEG - R | | 4 PCS |
| 4 | FRONT LEG - L | | 4 PCS |
| 5 | SEAT | | 4 PCS |

| NO. | DESCRIPTION | SKETCH | QTY |
|--------------|-------------------------|--------|---------------------|
| A | JCBC BOLT M6 X 75 mm | | 16 PCS |
| B | JCBC BOLT M6 X 60 mm | | 16 PCS |
| C | JCBC BOLT M6 X 38 mm | | 12 PCS |
| D | CSK SCREW M4 X 32 mm | | 12 PCS |
| E | SPRING WASHER M6 | | 44 PCS |
| F | FLAT WASHER M6 | | 44 PCS |
| G | ALLEN KEY M4 | | 1 PC |
| SCREW DRIVER | | | NOT INCLUDED |

STEP 1

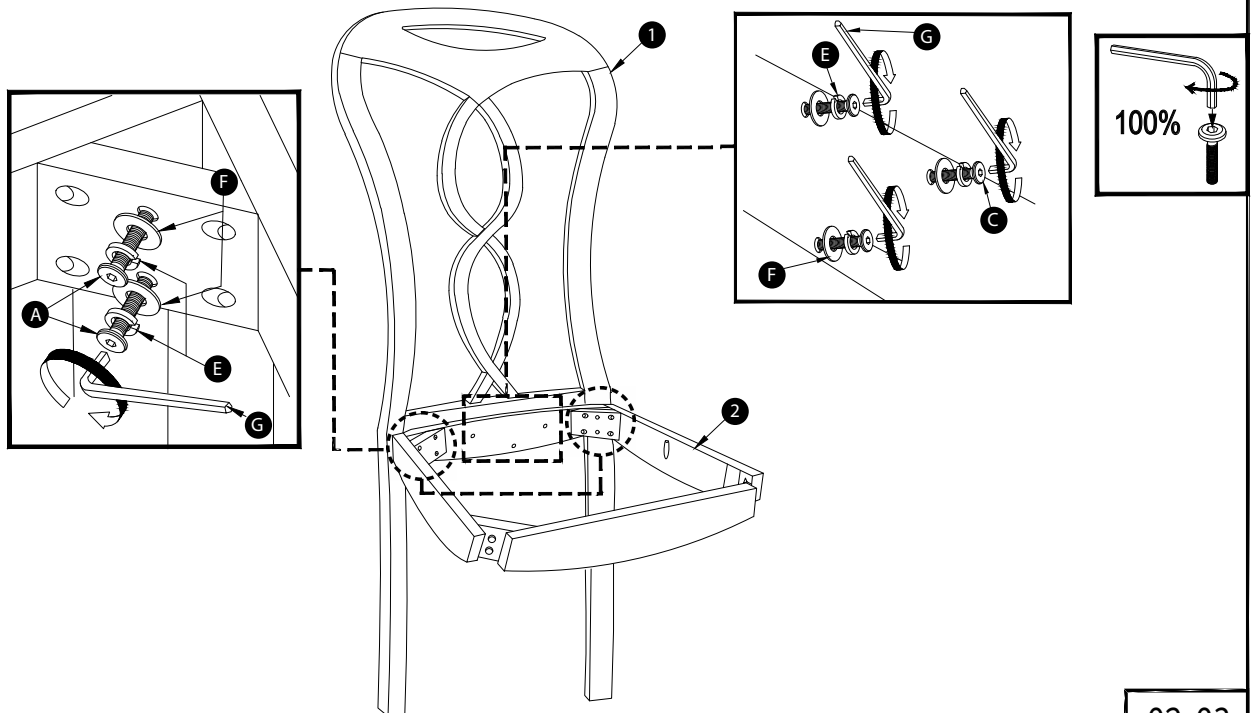

STEP 2

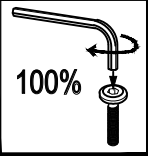
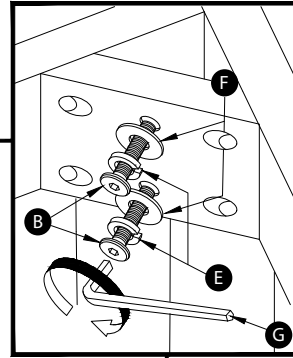
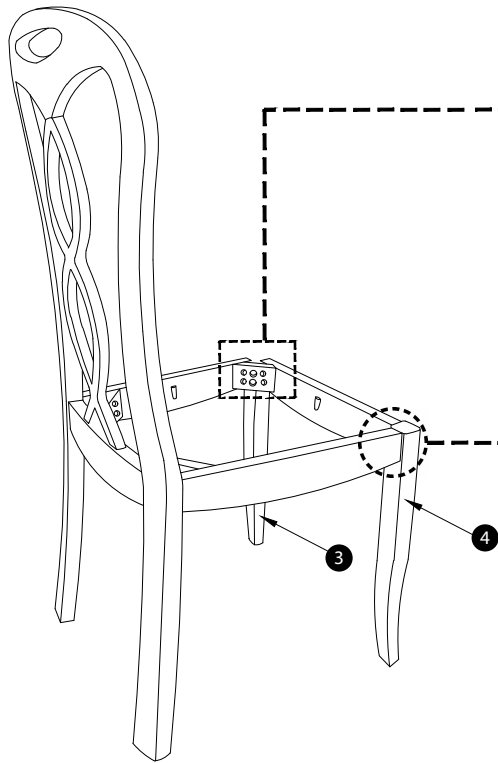

STEP 3

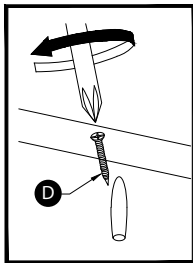

X 3

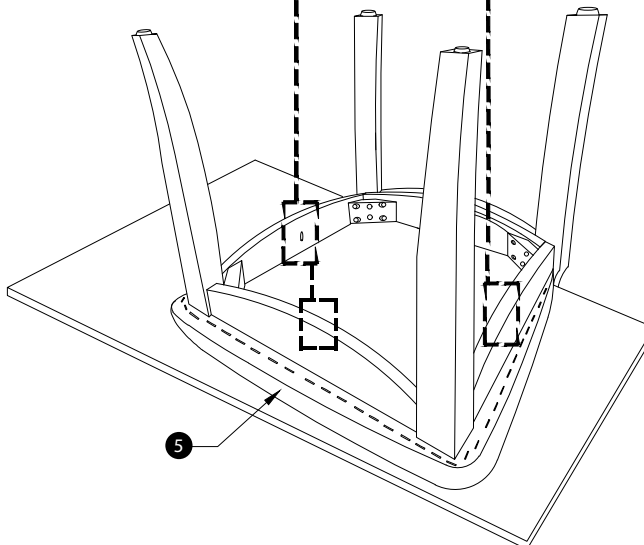

ASSEMBLY
COMPLETE !

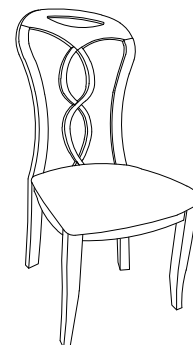

ASSEMBLY INSTRUCTIONS

DINING CHAIR

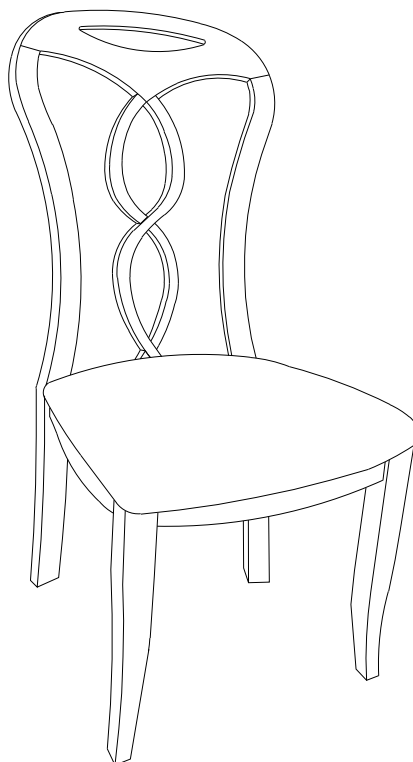

IMPORTANT NOTE:

- PLACE ALL PARTS ON A CLEAN AND SMOOTH SURFACE SUCH AS A RUG OR CARPET TO AVOID THE PARTS FROM BEING SCRATCHED.
- BEFORE YOU BEGIN, KINDLY FOLLOW THE ASSEMBLY INSTRUCTIONS STEP BY STEP.
- DO NOT TIGHTEN ALL SCREWS AND BOLTS UNTIL THE CHAIR IS FULLY SET-UP.

CARTON CONTENT:

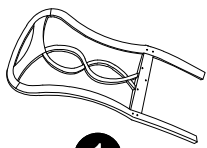

1 x 2

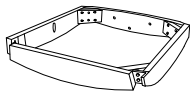

2 x 2



3 x 2



4 x 2

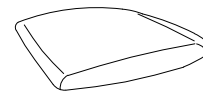

5 x 2

CHAIR PART LISTS

CHAIR HARDWARE LISTS

| NO. | DESCRIPTION | SKETCH | QTY |
|-----|---------------|--------|-------|
| 1 | CHAIR BACK | | 2 PCS |
| 2 | BOX SEAT | | 2 PCS |
| 3 | FRONT LEG - R | | 2 PCS |
| 4 | FRONT LEG - L | | 2 PCS |
| 5 | SEAT | | 2 PCS |

| NO. | DESCRIPTION | SKETCH | QTY |
|---------------------|-------------------------|--------|---------------------|
| A | JCBC BOLT M6 X 75 mm | | 8 PCS |
| B | JCBC BOLT M6 X 60 mm | | 8 PCS |
| C | JCBC BOLT M6 X 38 mm | | 6 PCS |
| D | CSK SCREW M4 X 32 mm | | 6 PCS |
| E | SPRING WASHER M6 | | 22 PCS |
| F | FLAT WASHER M6 | | 22 PCS |
| G | ALLEN KEY M4 | | 1 PCS |
| SCREW DRIVER | | | NOT INCLUDED |

STEP 1

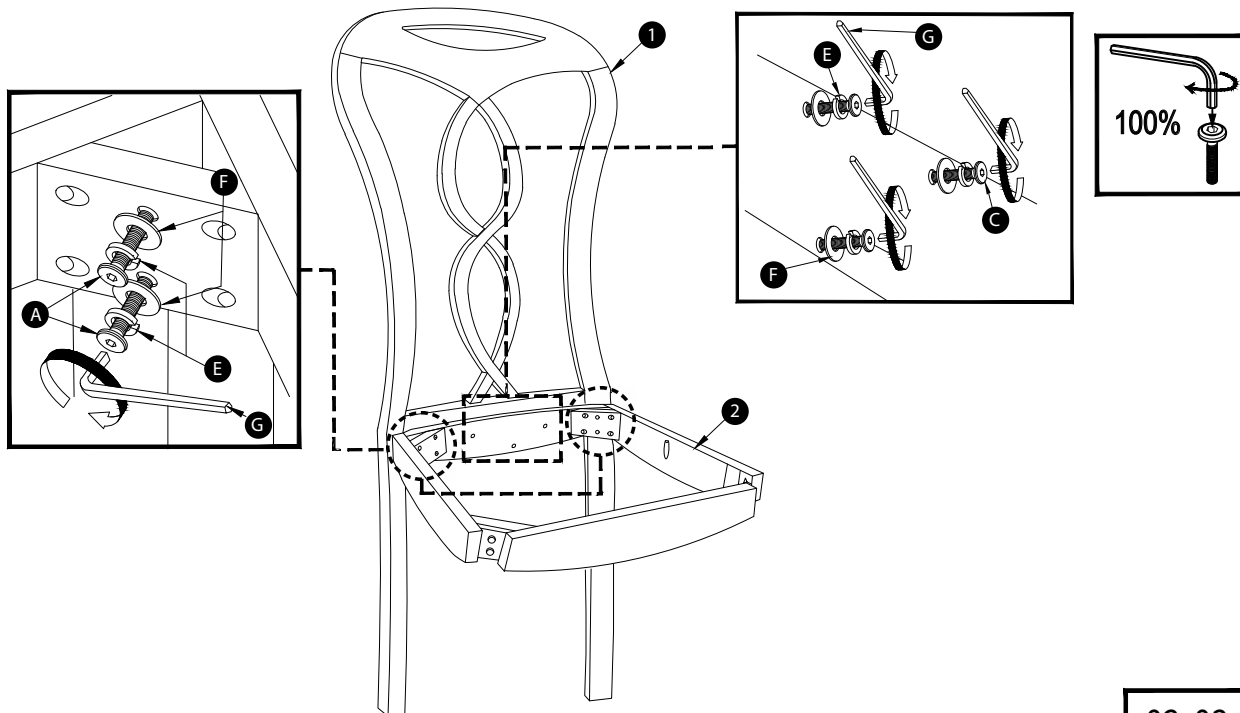

02-03

STEP 2

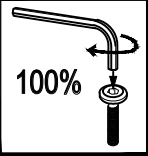
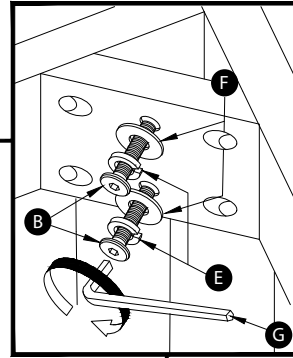
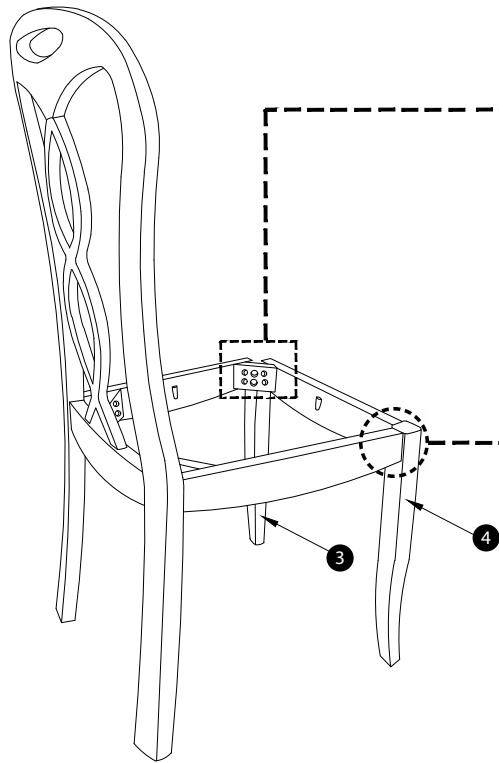

STEP 3

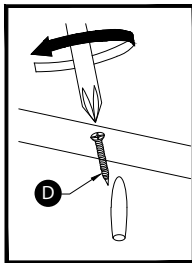

X 3

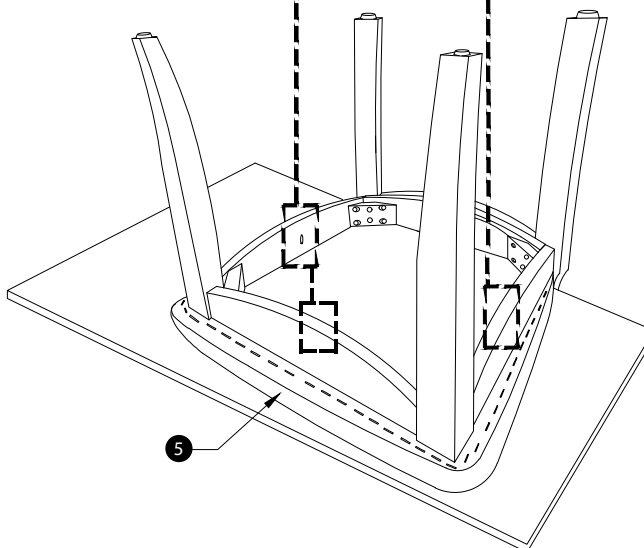

ASSEMBLY COMPLETE !

