

CrestwoodTM

Fireclay Sinks

CRESTWOOD FIRECLAY SINK INSTALLATION GUIDE

CAREFULLY READ THESE INSTRUCTIONS BEFORE INSTALLATION

- Fireclay sinks should be installed by a professional experienced installer following all local plumbing and building codes.
- Before installation, inspect the sink for damage and do not install a damaged sink.
- Due to the finished size variation (2% +/-) inherent in the fireclay manufacturing process, a sink cutout template is not provided. Use the actual sink for the countertop cutout.
- Domain Industries is not responsible for improper sink or countertop installations.
- Fireclay sinks are heavy. Please arrange for assistance to move or position.

INSTALLATION PROCEDURES:

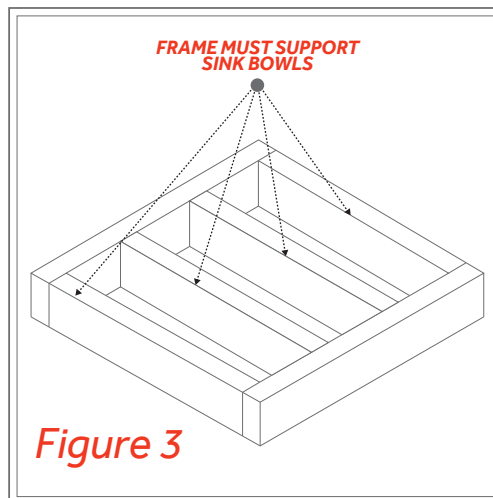
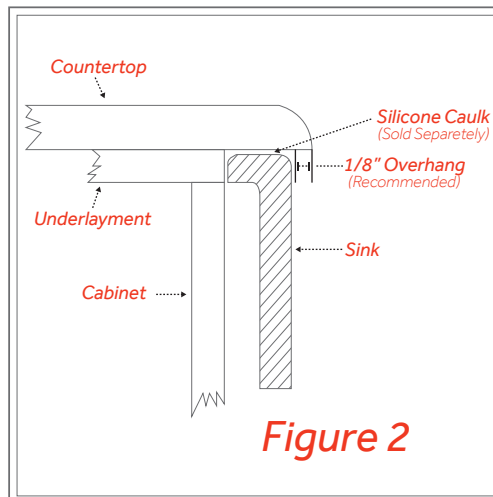
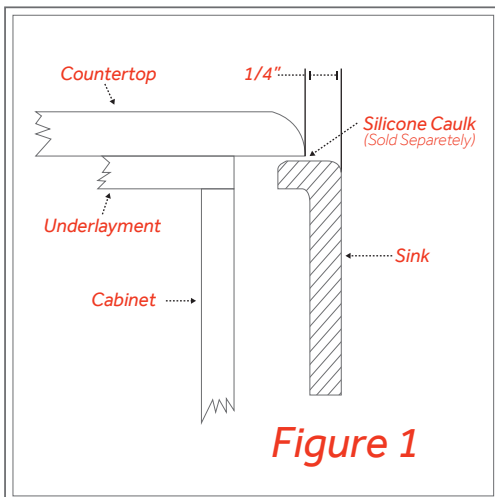

A template is not included, and due to the unique installation requirements, please provide the countertop or cabinet maker with the actual sink prior to fabrication. It is recommended for apron sinks to use a reveal into the sink bowl opening (Fig 1) and for Undermount sinks use a minimum 1/8" countertop cutout overhang (Fig 2).

Apron fireclay sinks require a custom sink base and support system for installation. The cabinet area beneath the sink **MUST** be reinforced to provide sufficient support. Use a wood or metal support frame (Fig 3) capable of supporting 400lbs (approximate weight of the sink with water).

Undermount fireclay sinks require a reinforced cabinet and a wood or metal support frame capable of supporting 300lbs (approximate weight of the sink with water) and an additional mounting bar such as the Domain Industries Sink Undermounter (SKU# VA-UM23-STEEL) can aid in leveling.

Shimming may be necessary to level the sink so it is properly positioned in relation to the countertop and to ensure proper drainage. Test for proper drainage before leaving the jobsite.