

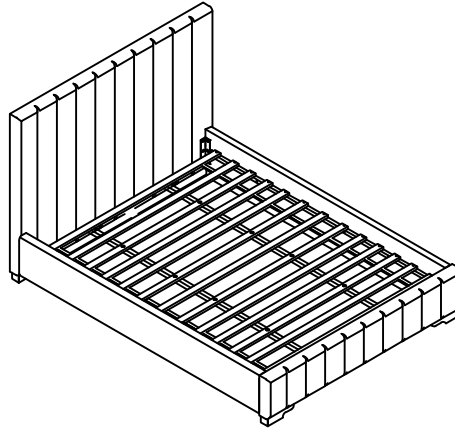







ASSEMBLY INSTRUCTION



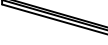





KING BED



Part list

No.	Parts	Description	QTY
A		Headboard	1
B		Footboard	1
C		Side Rail	2
D		Wood strip for Side rail	2
E		Slats	13
F		Center support rails	2
G		Wood Block on Headboard & Footboard	4
H		Center leg	8

Hardware

No.	Parts	Description	QTY
1		Bolt 5/16**25mm	24
2		Flat Washer 5/16"	24
3		Lock washer 5/16"	48
4		Bolt 1/4**60mm	24
5		Flat Washer 1/4"	24
6		Screw #8*30mm	30
7		Large L metal connector	4
8		Allen Wrench	1

ASSEMBLY TOOLS REQUIRED (NOT INCLUDED)

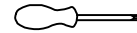

PLEASE BE CAREFUL DO NOT DAMAGE THE HOLE POSITION WHEN YOU USE POWER TOOLS!

STEP 1:

Attach Large L metal connector (7) to Side rail (C), Headboard (A) and Footboard (B) with Bolt (1), Lock washer (3) and Flat washer (2). Tighten with Allen Wrench (8).

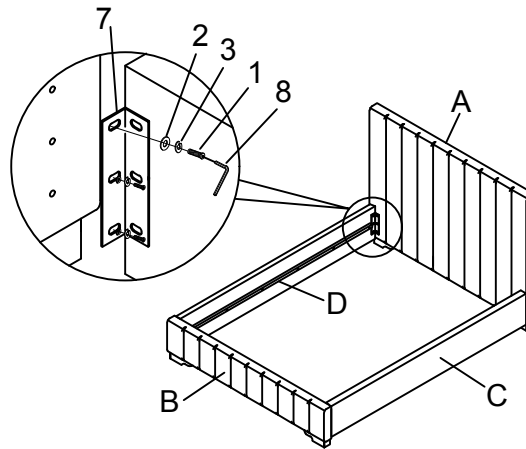

STEP 2:

Attach Wood strip for Side rail (D) to Side rail (C) with Bolt (4), Lock washer (3) and Flat washer (5). Tighten with Allen Wrench (8).

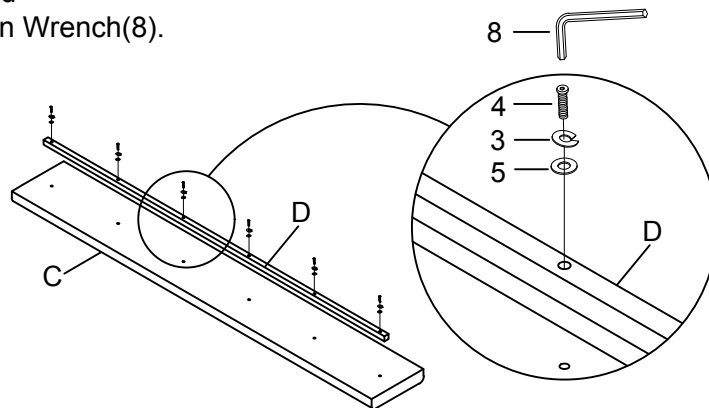

STEP 3:

Attach Wood Block on Headboard & Footboard (G) to Headboard (A) and Footboard (B) with Bolt (4), Lock washer (3) and Flat washer (5). Tighten with Allen Wrench (8).

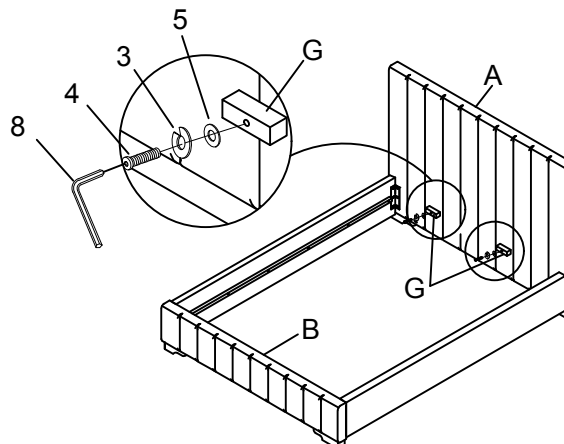

STEP 4:

Attach Center support rails (F) to Headboard (A) and Footboard (B) with Screw (6).

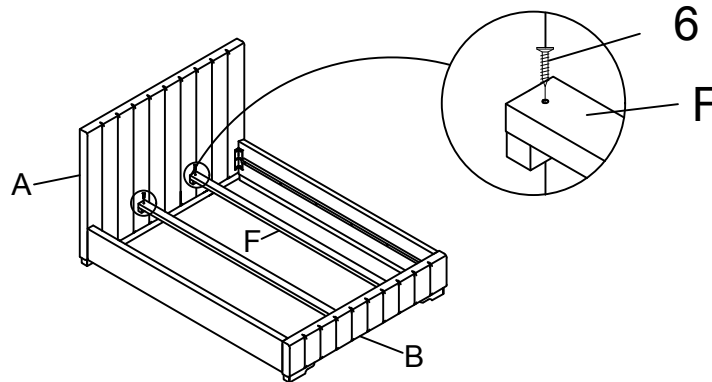

STEP 5:

Attach Center leg (H) to Center support rails (F) and Slats (E) with Bolt (4). Lock washer (3) and Flat washer (5). Tighten with Allen Wrench (8).

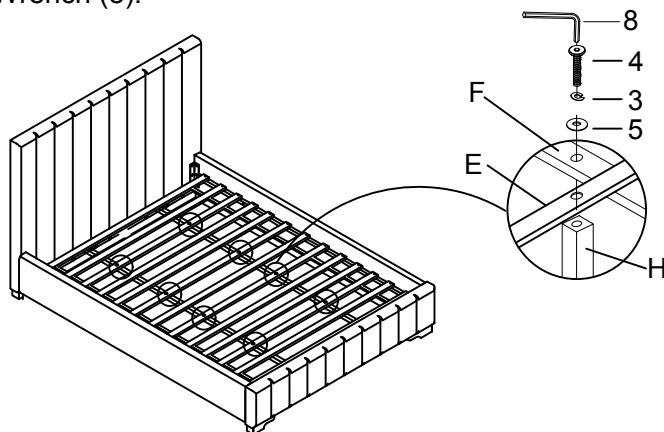

STEP 6:

Attach Slats (E) to Side rail (C) with Allen Screw (6).

