

Assembly Instructions

This instruction booklet contains important safety information, please read and keep for future reference.

ITEM # HIBT60-G

SINGLE BED

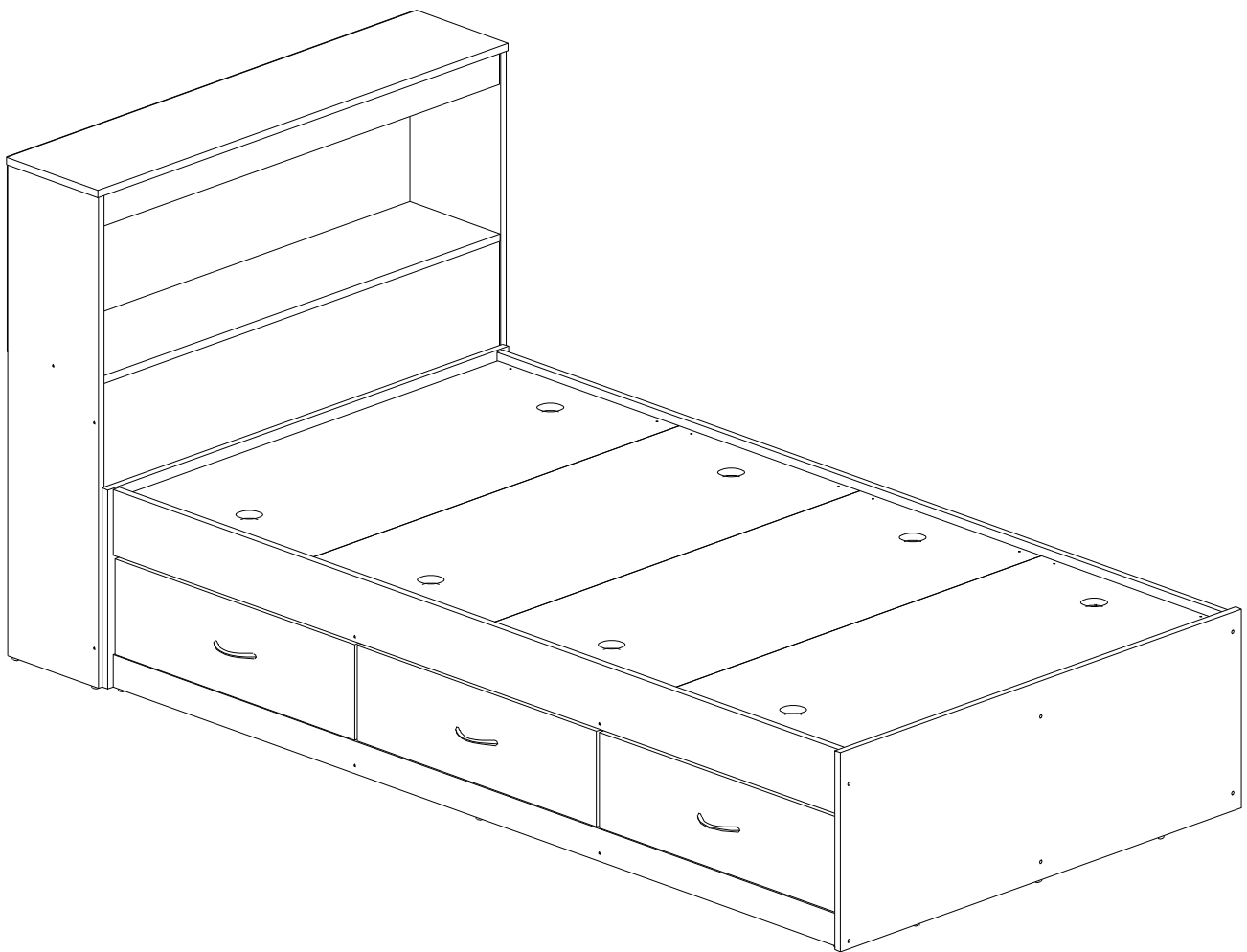

Product Dimensions: Height 39.17" x Width 42.32" x Depth 85.66"

Weight Capacity Per Drawer 20lbs

Weight Capacity Per Shelf 20lbs



Phone

Mon - Fri | 9:30 am to 5pm EST

1 - 855 - HODEDAH

1 - 855 - 463 -3324



Email

Send us an email

Support@Hodedah.com



Website

Visit our website to open a case

www.Hodedah.com

Questions, need parts, we are here to help!

FOR PROMPT, RELIABLE SERVICE PLEASE HAVE YOUR INSTRUCTION MANUAL READY



DO NOT RETURN PRODUCT TO THE STORE

If parts are missing or damaged please contact our customer service team and we will gladly ship your replacement parts FREE of charge within **ONE YEAR** of purchase!

WARRANTY

Hodedah warrants this product to be free from defects in materials and workmanship and agrees to remedy any such defect. This warranty covers one year from the date of original purchase. This is solely limited to replacement of defective parts and no assembly for labor is included. This warranty does not apply to any product that has been improperly assembled, subjected to misuse, abuse or which has been altered or repaired in any way. To obtain warranty service, original purchaser must present the following; original bill of sale, date of purchase, where the product was purchased and images if applicable. Components replaced warranted through the remainder of the original warranty only. The defective part will be replaced without charge, subject to the terms and conditions described above.

WARNING

- This product contains small parts, keep away from children.
- This product contains plastic bags, keep away from children.
- Serious or fatal crushing injuries can occur from furniture tip-over. To help prevent this, place heaviest items on the lower shelves and drawers. Do not set heavy objects on top shelves and drawers.
- Never allow children to climb or hang on drawers, shelves and doors.
- Never open more than one drawer at a time.
- The use of tip-over restraints may reduce but not eliminate the risk of tip-over.

- Never open more than one drawer at a time.
- The use of tip-over restranits may reduce but not eliminate the risk of tip-over.

Let's get started...

Helpful hints, read before beginning assembly

- Make sure you receive all boxes. If your item is packed in one box, box count will read 1 of 1, likewise if your item is packed in two boxes, box count will read 1 of 2 and second box will read 2 of 2.
- Read each step carefully. It is very important that each step is performed in the correct order. If these steps are not followed in sequence, assembly difficulties will occur.
- Work in a spacious level area, preferably carpet, near the place the unit will be used.
- **DO NO USE** power tools to assemble your furniture, it will strip and damage parts.
- Your package should include the following hardware and parts. Parts are labeled or stamped on the raw edge. Please inspect contents to ensure you have received all components. **If you are missing any hardware or parts please contact customer service right away before assembly.**

Assembly Tools Required (not supplied)

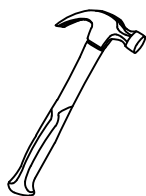

Hammer

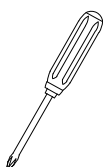

Phillips Screwdriver

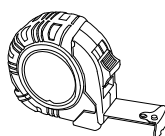

Tape Measure











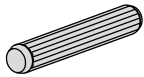

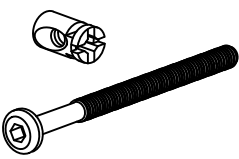
No Power Tools Needed



Product Care and Maintenance

- Wipe clean with dry soft cloth, never use chemicals or cleaning products they will damage the finish.
- Avoid placing your furniture in direct sunlight, as sunlight causes fading.
- Never push, drag or pull your furniture, to move to a new location carefully with two or more people carry the unit to its new location.
- Avoid extreme changes in temperature by arranging furniture away from radiators, heat and air vents and air conditioning units.

Hardware List

<p>1</p>  <p>Pvc Dowel</p>	<p>QTY</p> <input type="checkbox"/> 58 Pcs	<p>2</p>  <p>Screw M3.5 x 14mm *For # 13 Drawer Slides</p>	<p>QTY</p> <input type="checkbox"/> 18 Pcs	<p>3</p>  <p>Screw M4 x 32mm</p>	<p>QTY</p> <input type="checkbox"/> 39 Pcs
<p>4</p>  <p>JCBC-Bolt M6x60mm</p>	<p>QTY</p> <input type="checkbox"/> 12 Sets	<p>5</p>  <p>Screw M6.2 x 9mm *For # 12 Drawer Slides</p>	<p>QTY</p> <input type="checkbox"/> 12 Pcs	<p>6</p>  <p>Screw M6 x 40mm</p>	<p>QTY</p> <input type="checkbox"/> 16 Pcs
<p>7</p>  <p>Pvc Cap</p>	<p>QTY</p> <input type="checkbox"/> 16 Pcs	<p>9</p>  <p>Mini Fix Pvc Cap</p>	<p>QTY</p> <input type="checkbox"/> 19 Sets 19 Pcs	<p>10</p>  <p>Nail Leg</p>	<p>QTY</p> <input type="checkbox"/> 18 Sets
<p>11</p>  <p>Nail</p>	<p>QTY</p> <input type="checkbox"/> 50 Pcs	<p>14</p>  <p>Allen Key</p>	<p>QTY</p> <input type="checkbox"/> 1 Pc		

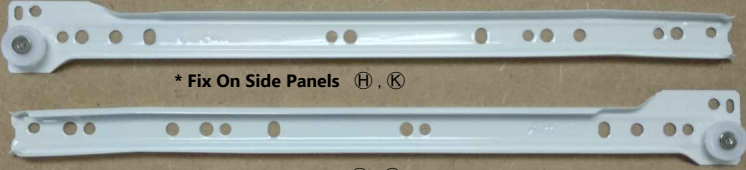
Accessories

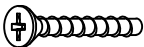
 <p>* Fix On Side Panels (H), (K)</p> <p>* Fix On Side Panels (K), (O)</p>	<p>12</p> <p>Drawer Slide - A</p> <p>*Fix On Side Panels (H) (K) & (O)</p>	<p>QTY</p> <p><input type="checkbox"/></p> <p>3 Sets</p>
 <p>* Fix On Drawer Side Panels (T)</p> <p>* Fix On Drawer Side Panels (U)</p>	<p>13</p> <p>Drawer Slide - B</p> <p>*Fix On Side Panels (T) (U)</p>	<p>QTY</p> <p><input type="checkbox"/></p> <p>3 Sets</p>
<p>8</p>  <p>Handle</p>  <p>Screw M4 X 20mm</p>	<p>QTY</p> <p><input type="checkbox"/></p> <p>3 Pcs</p> <p>6 Pcs</p>	

Important

1. Before you throw the package, please use the Check Box to identify the parts and hardware to ensure that you have everything you need.
2. Check and measure the bolts before applying them to parts.
3. Do not completely tighten all hardware until the entire assembly is complete, unless indicated otherwise.

Parts List

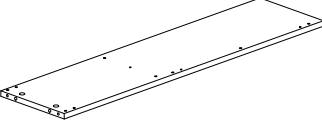
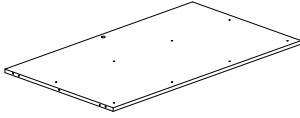
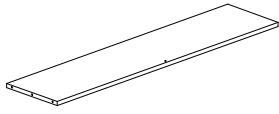
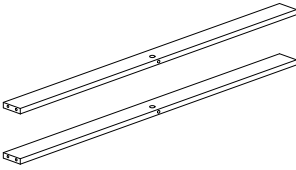
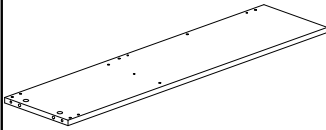
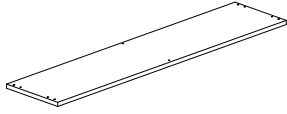
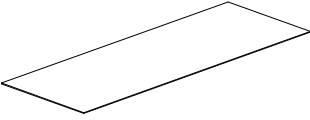
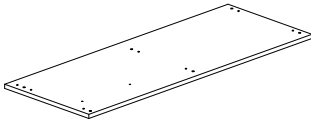
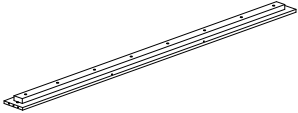
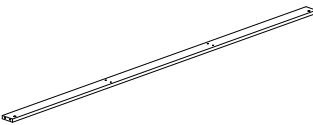
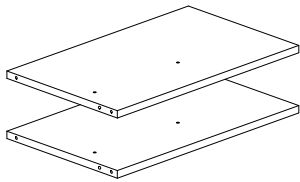
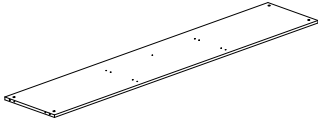
<p>A Headboard Left Side Panel 975 x 238 x 15mm</p> 	<p>QTY 1 Pc</p>	<p>B Headboard Stand Panel 1039 x 600 x 15mm</p> 	<p>QTY 1 Pc</p>	<p>C Headboard Fixed Panel 1039 x 237 x 15mm</p> 	<p>QTY 1 Pc</p>
<p>D Front & Back Strengthening Panel (Headboard) 1039 x 64 x 15mm</p> 	<p>QTY 2 Pcs</p>	<p>E Headboard Right Side Panel 975 x 238 x 15mm</p> 	<p>QTY 1 Pc</p>	<p>F Headboard Top Panel 1075 x 240 x 15mm</p> 	<p>QTY 1 Pc</p>
<p>G Headboard Back Panel 1066 x 387 x 3mm</p> 	<p>QTY 1 Pc</p>	<p>H Head Board Panel 1050 x 395 x 15mm</p> 	<p>QTY 1 Pc</p>	<p>I Left Side Rail (Upper) 1905 x 130 x 15mm</p> 	<p>QTY 1 Pc</p>
<p>J Left Side Rail (Lower) 1905 x 64 x 15mm</p> 	<p>QTY 1 Pc</p>	<p>K Stand Panel (Side Rail) 488 x 297 x 15mm</p> 	<p>QTY 2 Pcs</p>	<p>L Center Panel 1905 x 354 x 15mm</p> 	<p>QTY 1 Pc</p>

Parts List

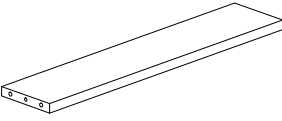
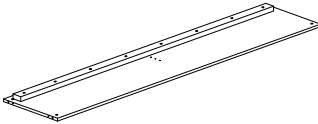
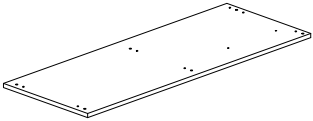
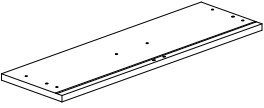
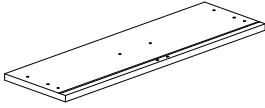
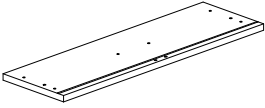
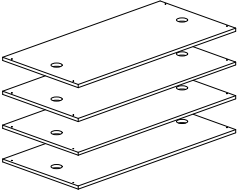
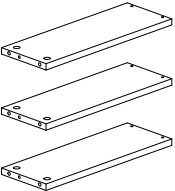
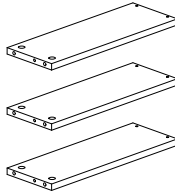
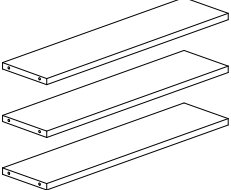
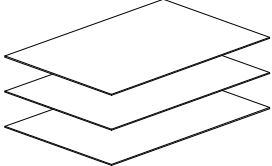
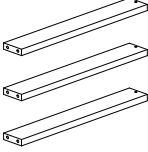
<p>M Center Support 487 x 100 x 15mm</p> 	<p>QTY 1 Pc</p>	<p>N Right Side Panel 1905 x 392 x 15mm</p> 	<p>QTY 1 Pc</p>	<p>O Foot Board Panel 1050 x 395 x 15mm</p> 	<p>QTY 1 Pc</p>
<p>P Left Drawer Panel 629 x 190 x 15mm</p> 	<p>QTY 2 Pcs</p>	<p>Q Mid Drawer Panel 629 x 190 x 15mm</p> 	<p>QTY 2 Pcs</p>	<p>R Right Drawer Panel 629 x 190 x 15mm</p> 	<p>QTY 2 Pcs</p>
<p>S Mattress Panels 988 x 475 x 15mm</p> 	<p>QTY 4 Pcs</p>	<p>T Left Drawer Side Panels 394 x 140 x 15mm</p> 	<p>QTY 3 Pcs</p>	<p>U Right Drawer Side Panels 394 x 140 x 15mm</p> 	<p>QTY 3 Pcs</p>
<p>V Drawer End Panels 569 x 138 x 15mm</p> 	<p>QTY 3 Pcs</p>	<p>W Drawer Base Panels 596 x 400 x 3mm</p> 	<p>QTY 3 Pcs</p>	<p>X Drawer Base Supporting Panels 394 x 56 x 15mm</p> 	<p>QTY 3 Pcs</p>

The Breakdown

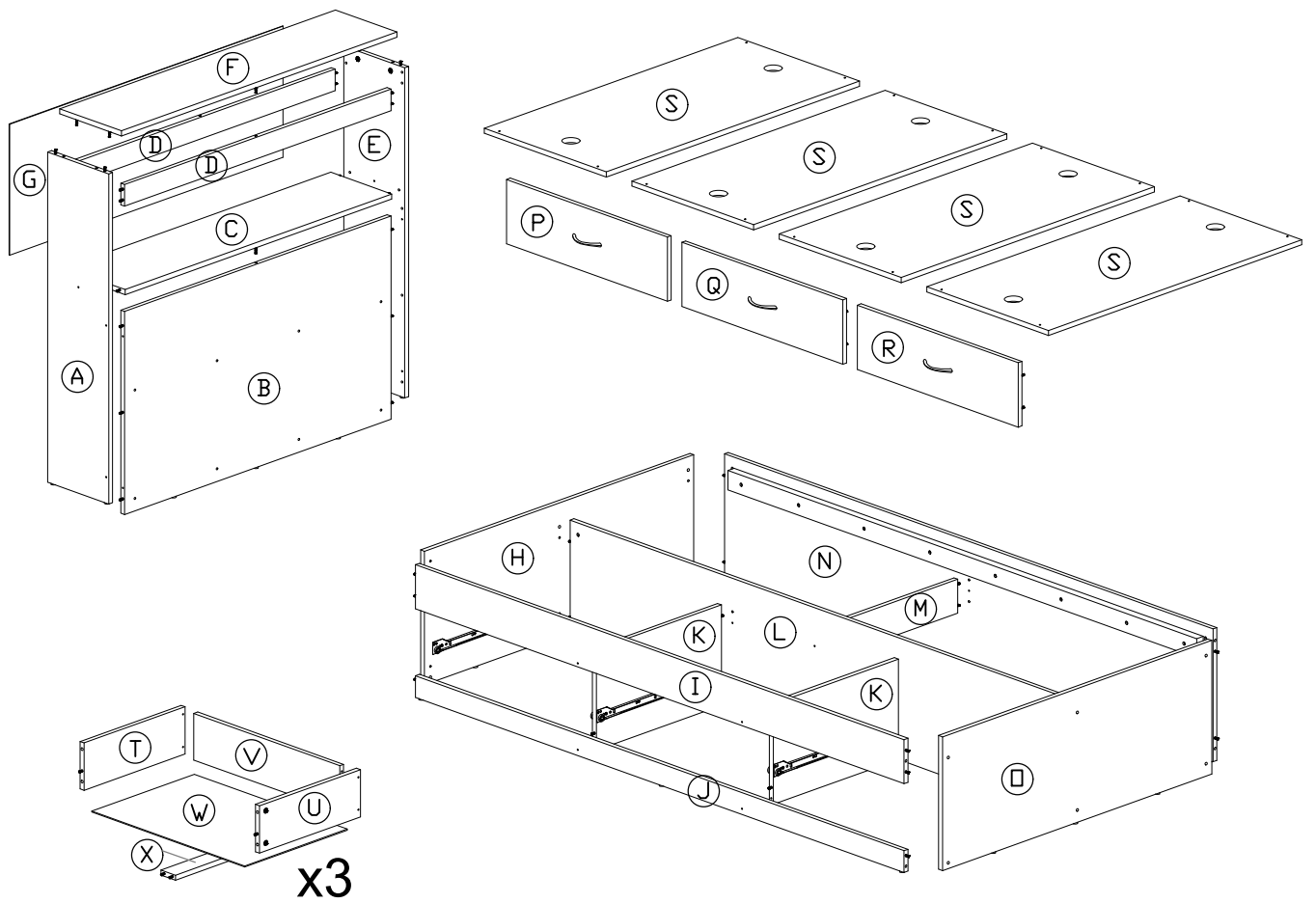

Pre - Assembly

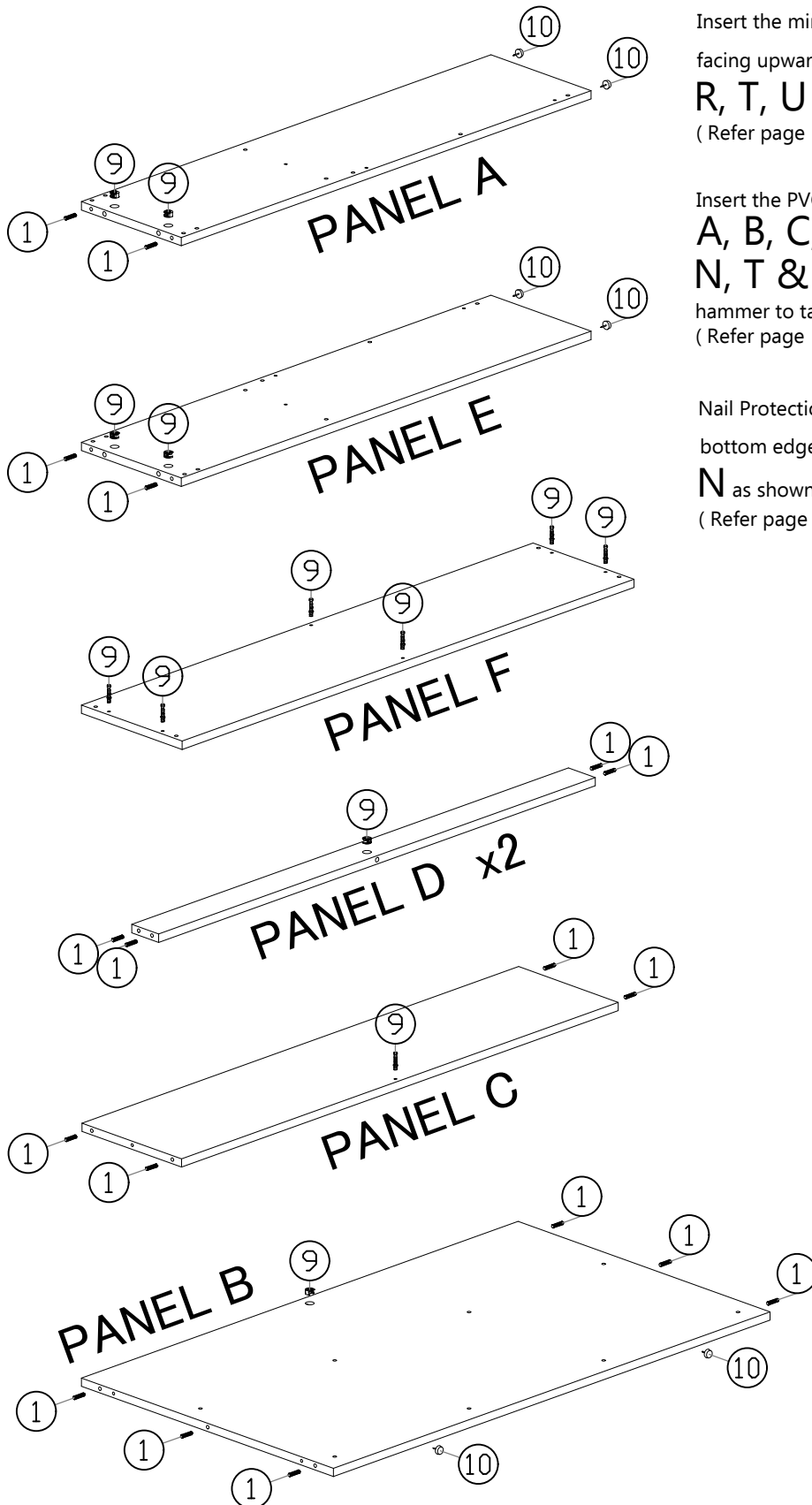

Insert the mini fix ⑨ (nuts) with the cross arrow mark facing upward and aim to panel **A, E, P, Q, R, T, U & X** 's top thru holes. (As shown) (Refer page 10)

Insert the PVC dowels ① to panel **A, B, C, D, E, K, I, J, L, M, N, T & X**'s non-thru holes as shown, using hammer to tap them in. (Refer page 10)

Nail Protection Nail ⑩, provided with hammer onto the bottom edge of panel **A, B, E, H, J, L & N** as shown. (Refer page 10)

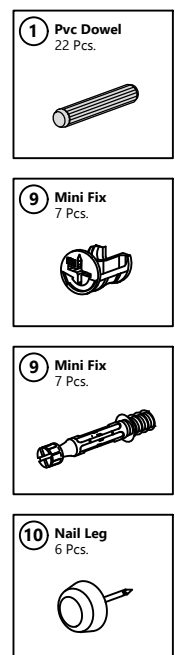

HODEDAH®

Pre - Assembly

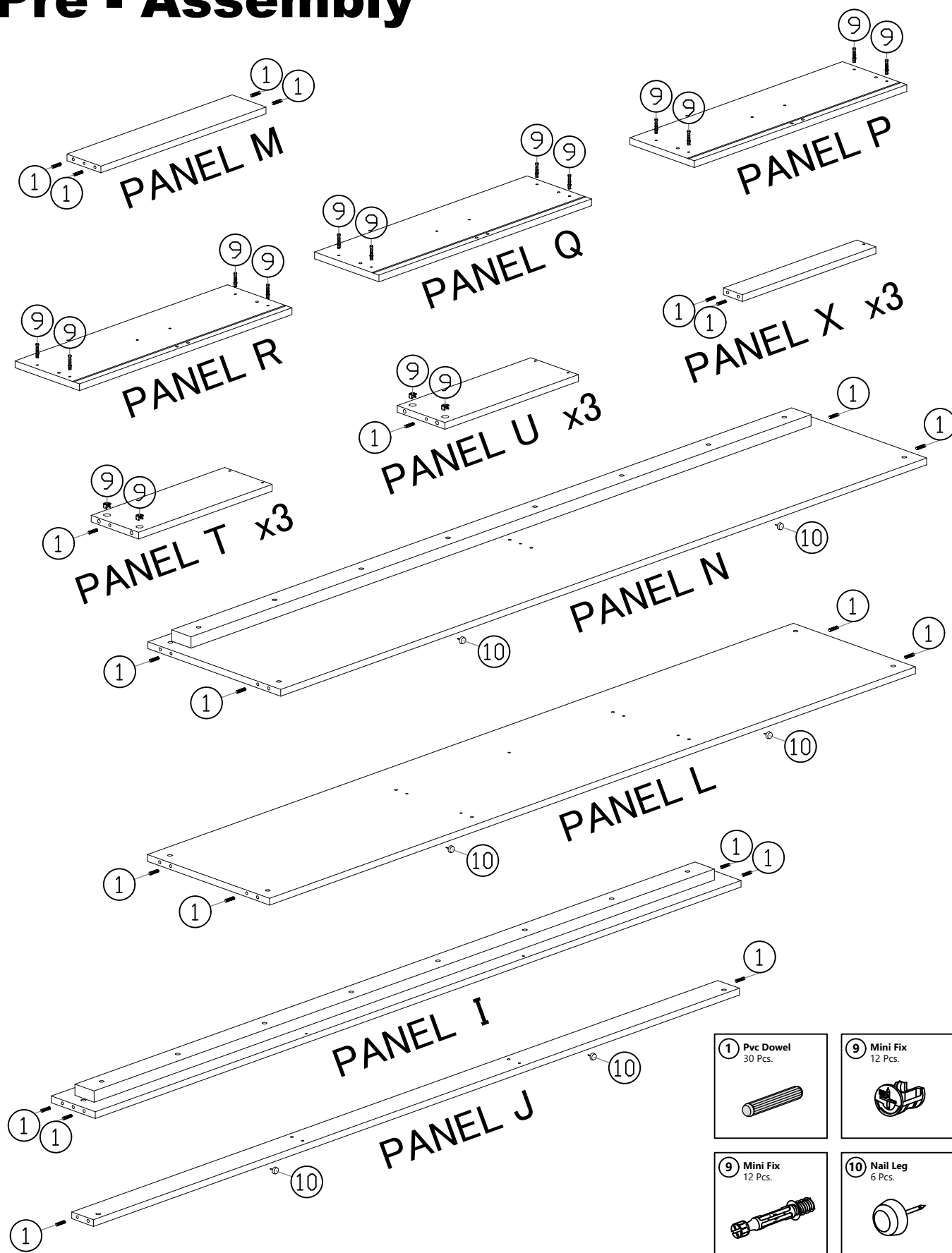

HODEDAH®

Pre - Assembly

Place the drawer slide A (12) onto the 2 holes area shown at panel H, K and O. Then tighten it with 2 screws (5).

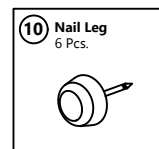
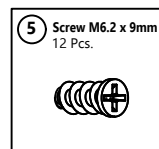
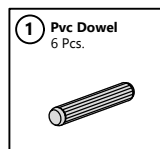
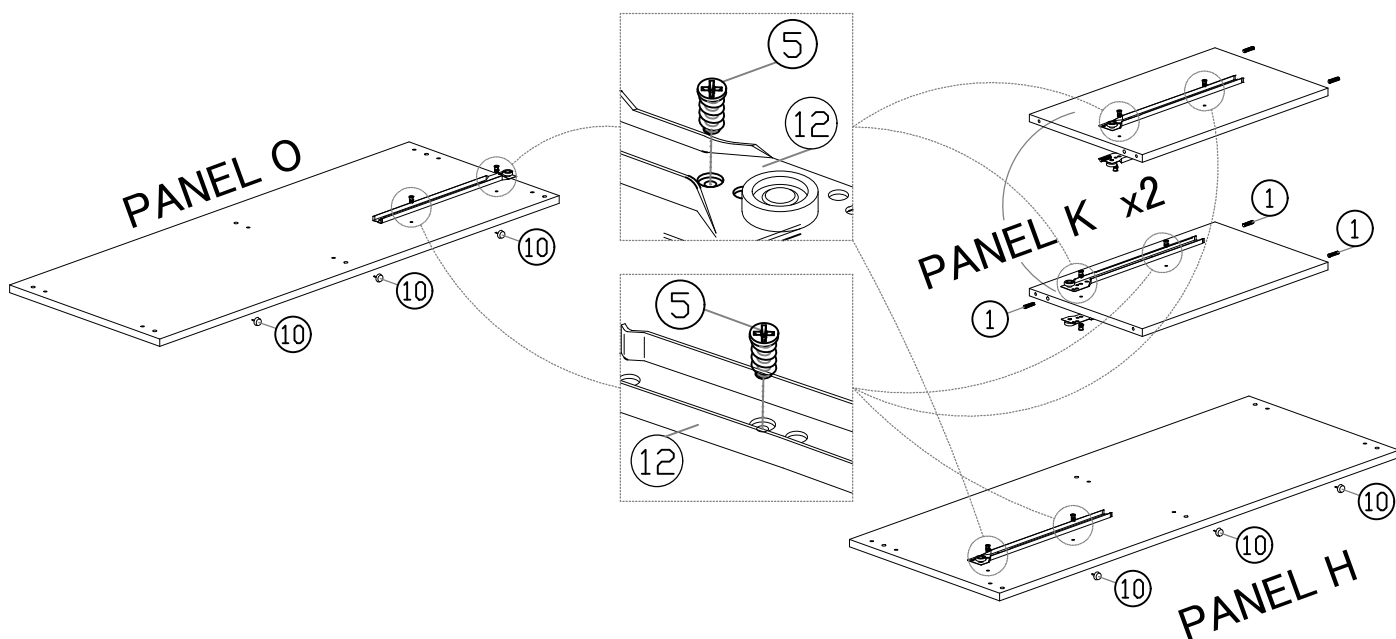

Assembly Of Drawers

A. Place panel **T** and **U** on each side of panel **P, Q & R** with Panel **T** and **U**'s PVC dowel insert to panel **P, Q & R**'s non-thru hole and Panel **P, Q & R**'s mini fix screws insert into Panel **T** and **U**'s thru as shown.

Then tighten mini fix on panel **T** and **U** clockwise to lock mini fix up.

-Next tighten screw **4** to panel **T** and **U**'s upper thru holes to fix up to the panel **V**.

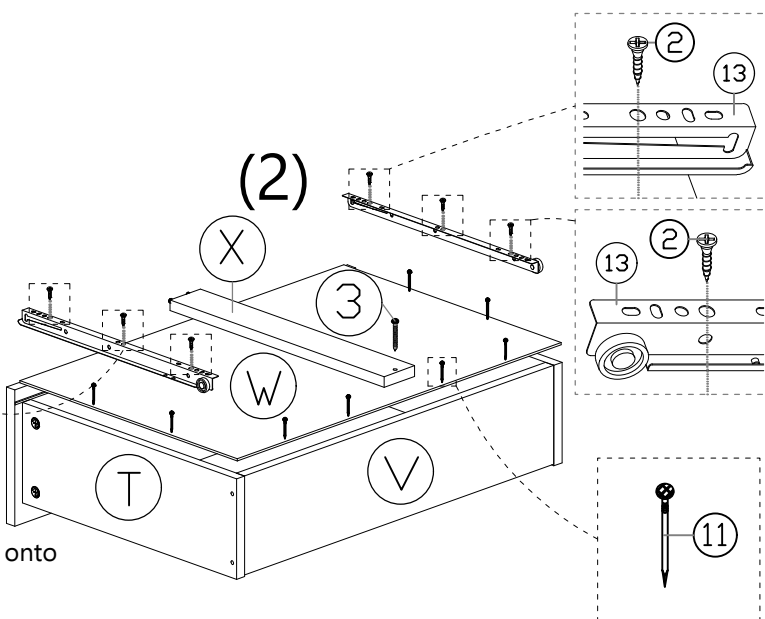
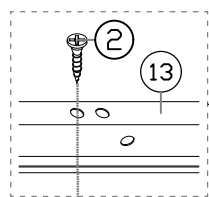
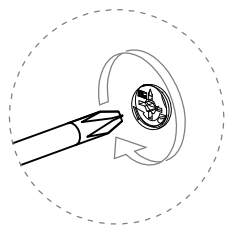
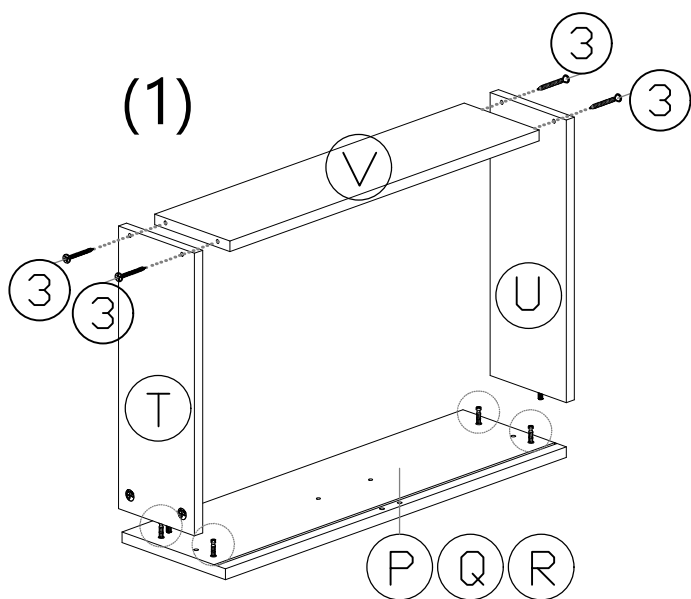

B. Flip drawer with bottom side up, place panel **W** onto the drawer and align properly. Then nail the nails provided with hammer on the border of panel **W** as shown. The gap between 2 nails is about 100mm.
-After that, place a drawer slide **B** (19) with the small white roller facing outward and with other end tip touching panel **P, Q & R** onto each bottom side (angle edge

of panel **T** and **U**. Then tighten 3 screws **8** on each drawer slide **B** (19) (as shown).

-Put drawer supporting **X** onto middle of panel **W** and inserting drawer supporting **X**'s dowels onto non-thru holes at Panel **P, Q & R**, then tighten screw **9** to drawer supporting **X**'s thru hole to fix it onto panel **W** and panel **V**.

C. Flip the drawer over.

-Tighten 2 screw **8** from inner side of panel **H** into the handle **8** holes.

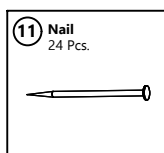
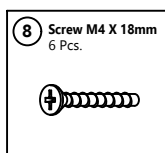
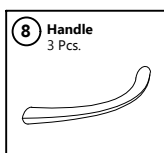
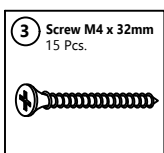
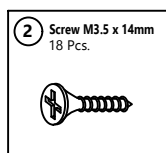
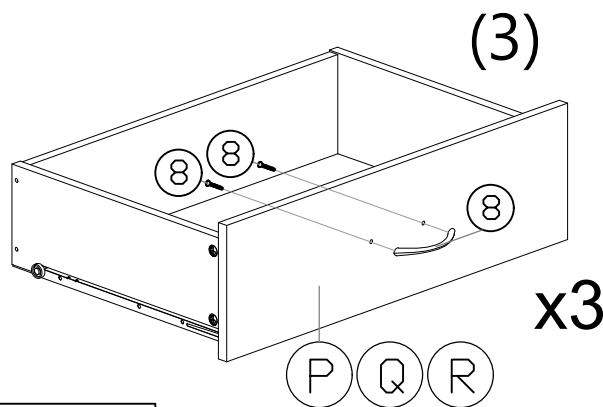

Assembly Of Set A

Step 1

- Fix both panel **K** onto Panel **L** by inserting the dowels onto the respective non-thru holes at panel **L**.
- Use Allen Key ⑭ to tighten 4 screws ⑥ from thru-holes of panel **L** to non-thru hole of both panel **K** as shown.
- Fix panel **M** to panel **L** and **N** by inserting the dowels onto the respective non-thru holes at panel **L** and **N**.
- Use Allen Key ⑭ to tighten 4 screws ⑥ from thru-holes of panel **L** and **N** to non-thru hole of panel **M** as shown.

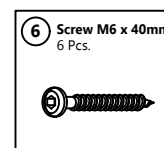
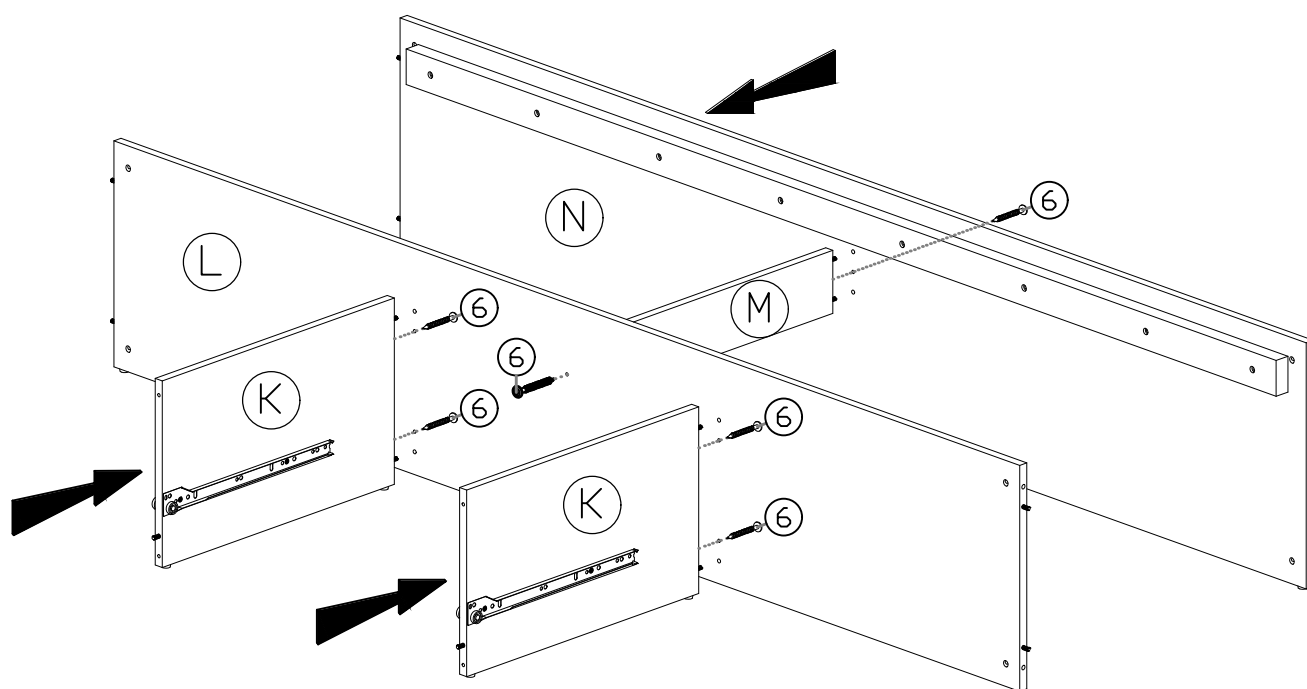

Assembly Of Set A

Step 2

- Fix panel **I** and **J** onto panel **K** by inserting the dowels onto the respective non-thru holes at panel **I** and **K**.
- Use Allen Key ⑭ to tighten 4 screws ⑥ from thru-holes of panel **I** and **J** to non-thru hole of both panel **K** as shown.
- Insert 6 barrel nuts ④ to non-thru holes at Panel **I, J, L & N**.
- Fix panel **O** onto panel **I, J, L & N**. Align properly by inserting the dowel of Panel **I, J, L & N** onto non-thru holes of panel **O**.
- Pushing & light tapping of panel **O** to have panel **I, J, L & N** fix tightly.
- Then insert 6 screws ④ onto thru holes at Panel **O**. Use Allen Key ⑭ to tighten all screws ④.

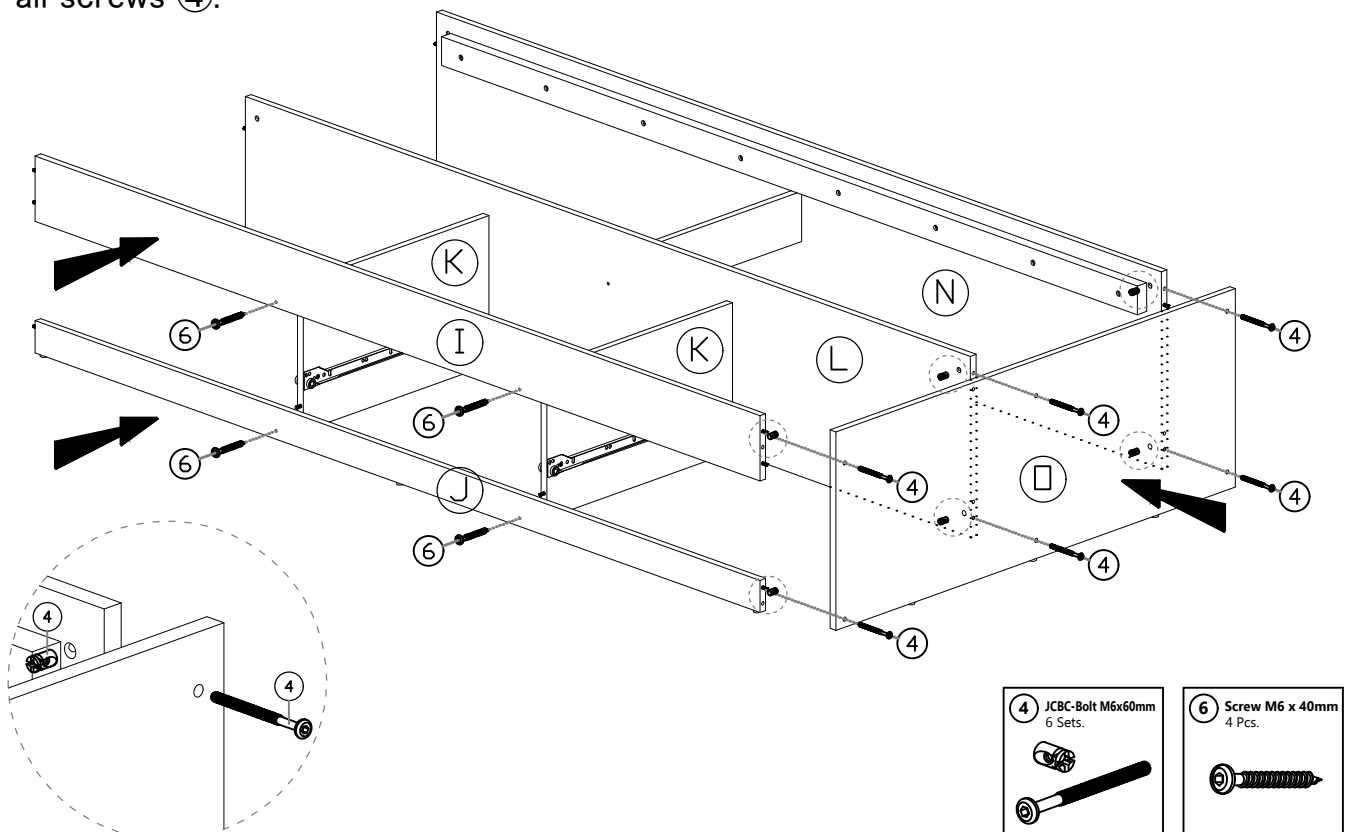

HODEDAH®

Assembly Of Set A

Step 3

- Insert 6 barrel nuts ④ to non-thru holes at Panel **I, J, L & N** as shown.
- Fix panel **H** onto panel **I, J, L & N**. Align properly by inserting the dowel of Panel **I, J, L & N** onto non-thru holes of panel **H**.
- Pushing & light tapping of panel **H** to have panel **I, J, L & N** fix tightly.
- Then insert 6 screws ④ onto thru holes at Panel **H**. Use Allen Key ⑭ to tighten all screws ④.

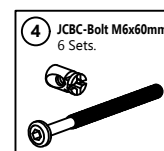
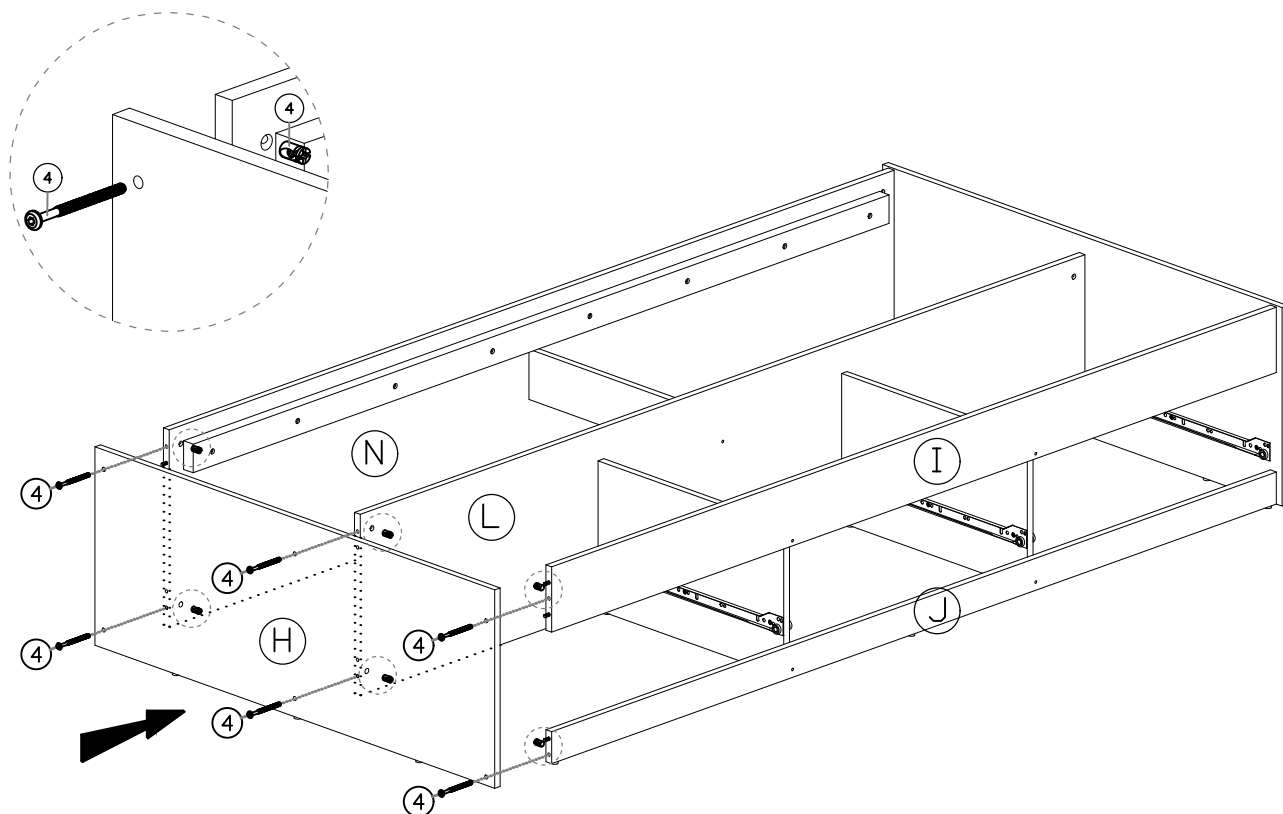

HODEDAH®

Assembly Of Set A

Step 4

- Place 4 panels **S** onto the middle of bed.
- Insert screws **③** onto the thru holes at Panel **S**.

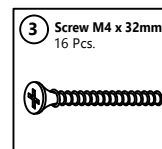
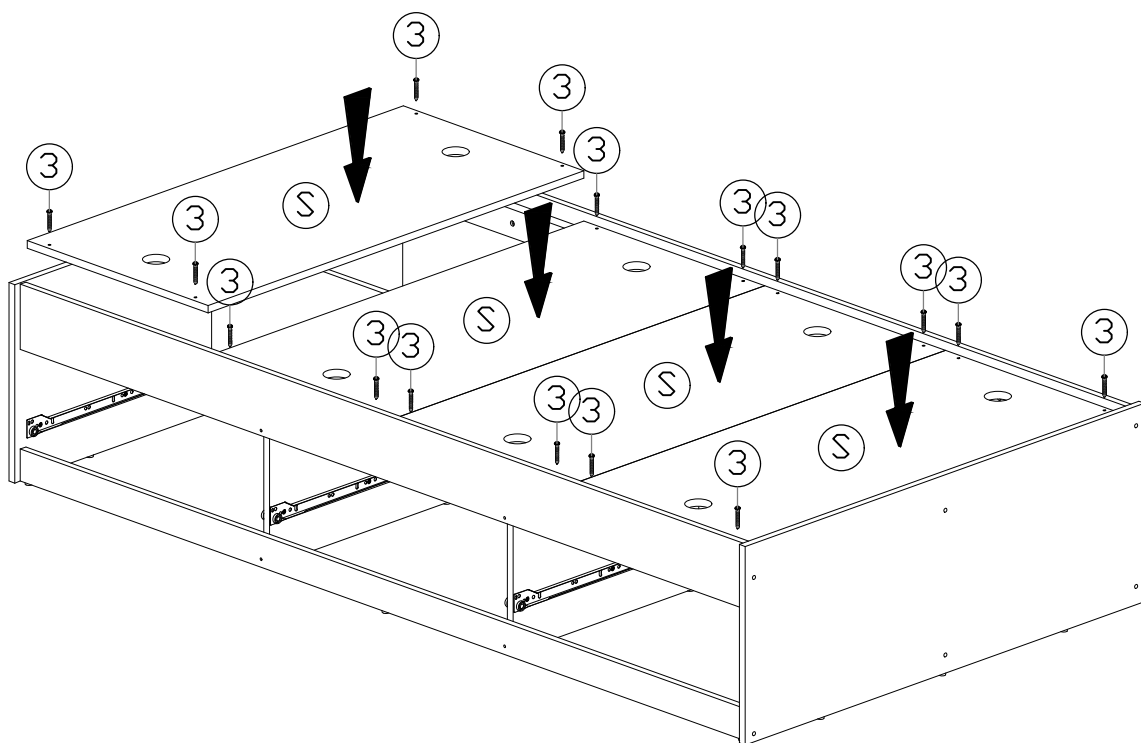

HODEDAH®

Assembly Of Set A

Step 5

Take drawers and slide them (the white rollers at drawer slide at both side of drawers are to go into the track of the slides at each side panel.) all the way gently.

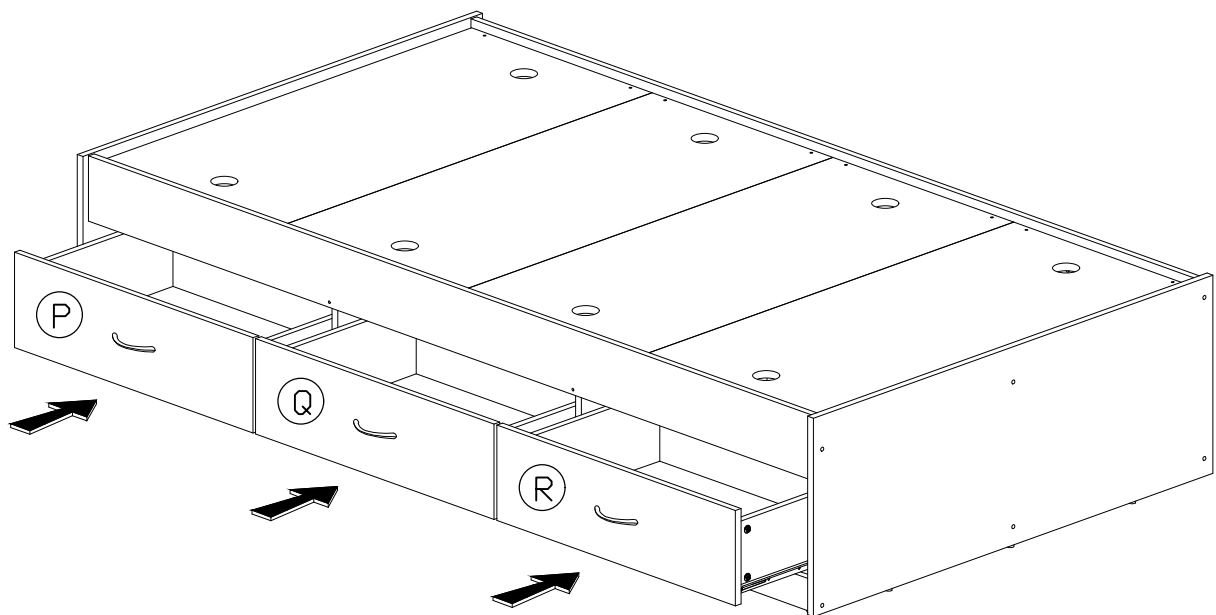

Assembly Of Set B

Step 1

- Fix panel **B** onto panel **C** by inserting the dowels onto the respective non-thru holes at panel **C**.
- Fix panel **A** onto panel **B, C & D** by inserting the dowels onto the respective non-thru holes at panel **A**.
- Use Allen key ⑭ to tighten 3 screws ⑥ from the thru-holes of panel **A** to non-thru holes of panel **B & C**.
- Fix panel **E** onto panel **B, C & D** by inserting the dowels onto the respective non-thru holes at panel **E**.
- Use Allen key ⑭ to tighten 3 screws ⑥ from the thru-holes of panel **E** to non-thru holes of panel **B & C**.
- Fix panel **F** onto panel **A, E & D**. Align properly by inserting the dowel of Panel **A, E & D** onto non-thru holes of panel **F**.
- Pushing & light tapping of panel **F** to have panel **A, E & D** fix tightly.

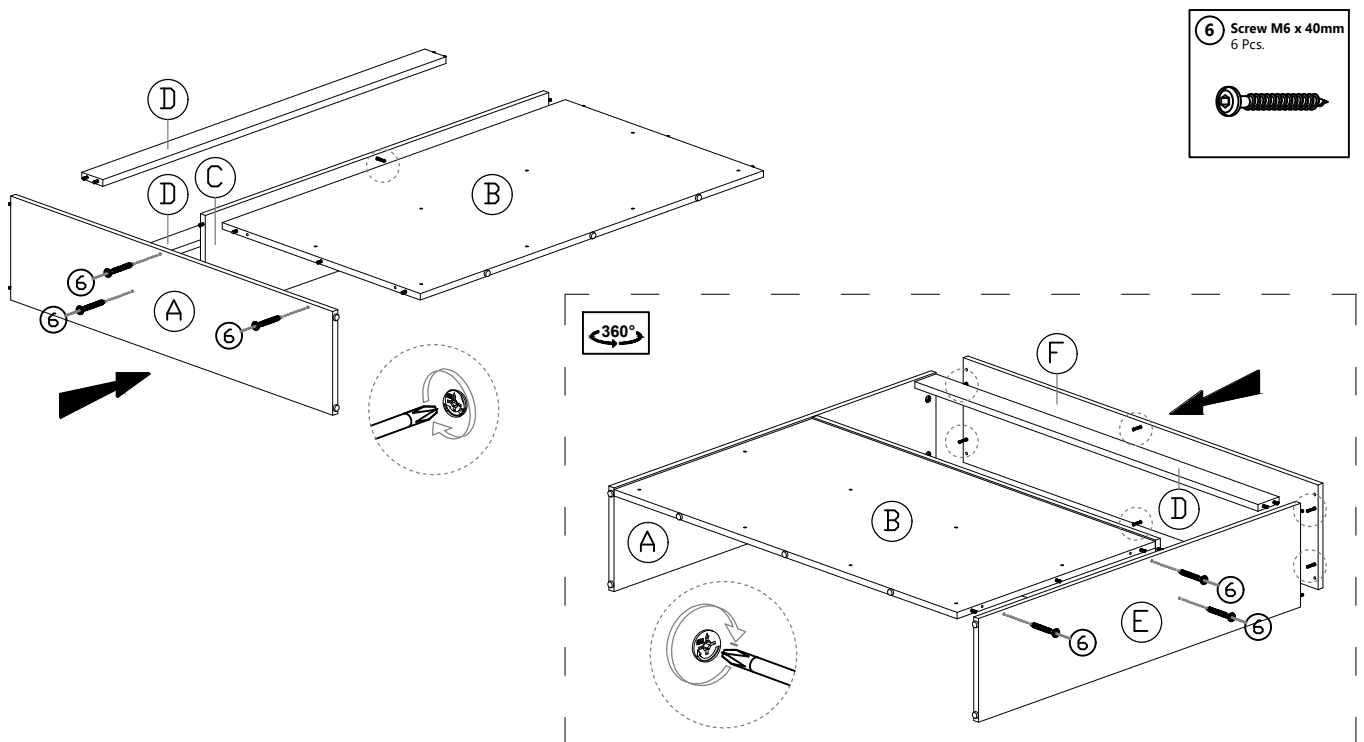

HODEDAH®

Assembly Of Set B

Step 2

- Place panel **G** onto panel **A**, **E** & **F** as shown.
- Then, align the Panel **G** properly for nailing.
- Use Hammer to nail Then use hammer to nail the nails one by one and at center of 4 side edges. Gap between 2 nails should be about 100mm for all.

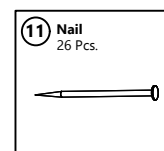
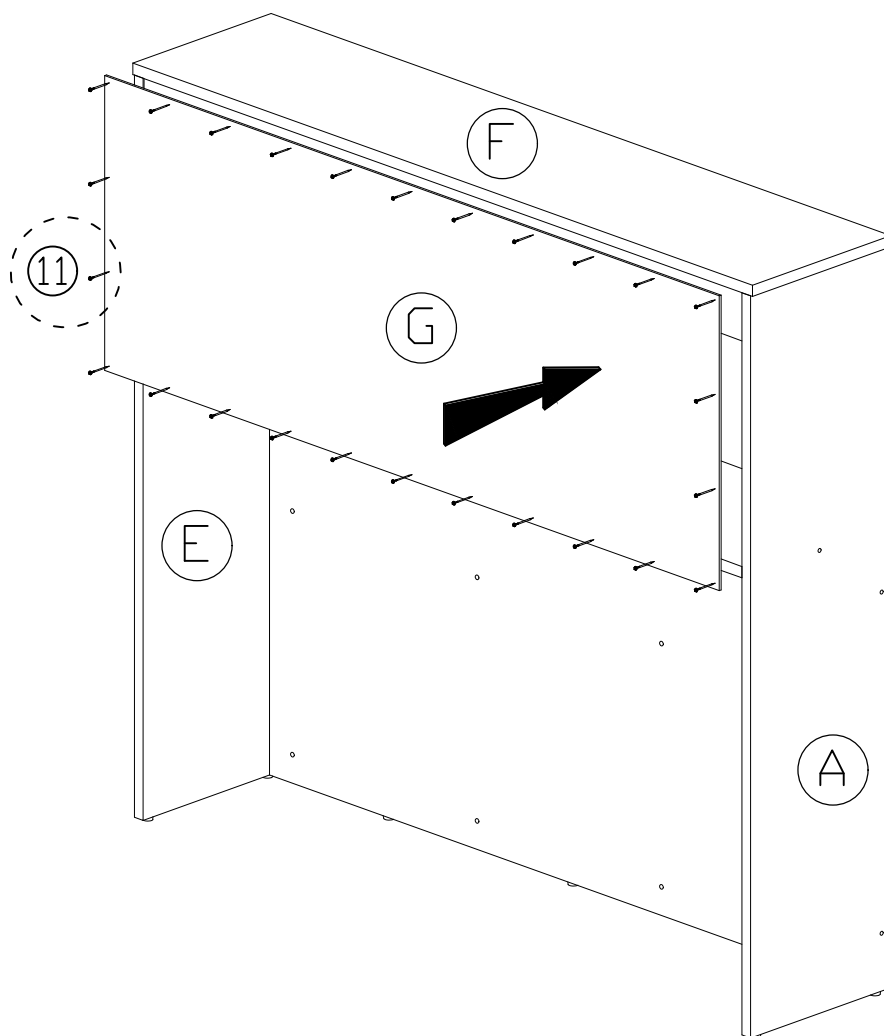

HODEDAH®

Assembly Of Set B

Step 3

- Joint the completed set A to set B.
- Insert 8 screws (3) from the inner of set B.
- Cover all the screws 's head with the PVC cap provided by pushing the cover's stem onto the hole of screw head one by one.

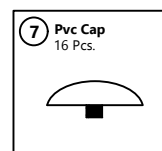
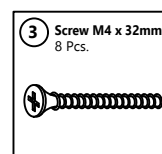
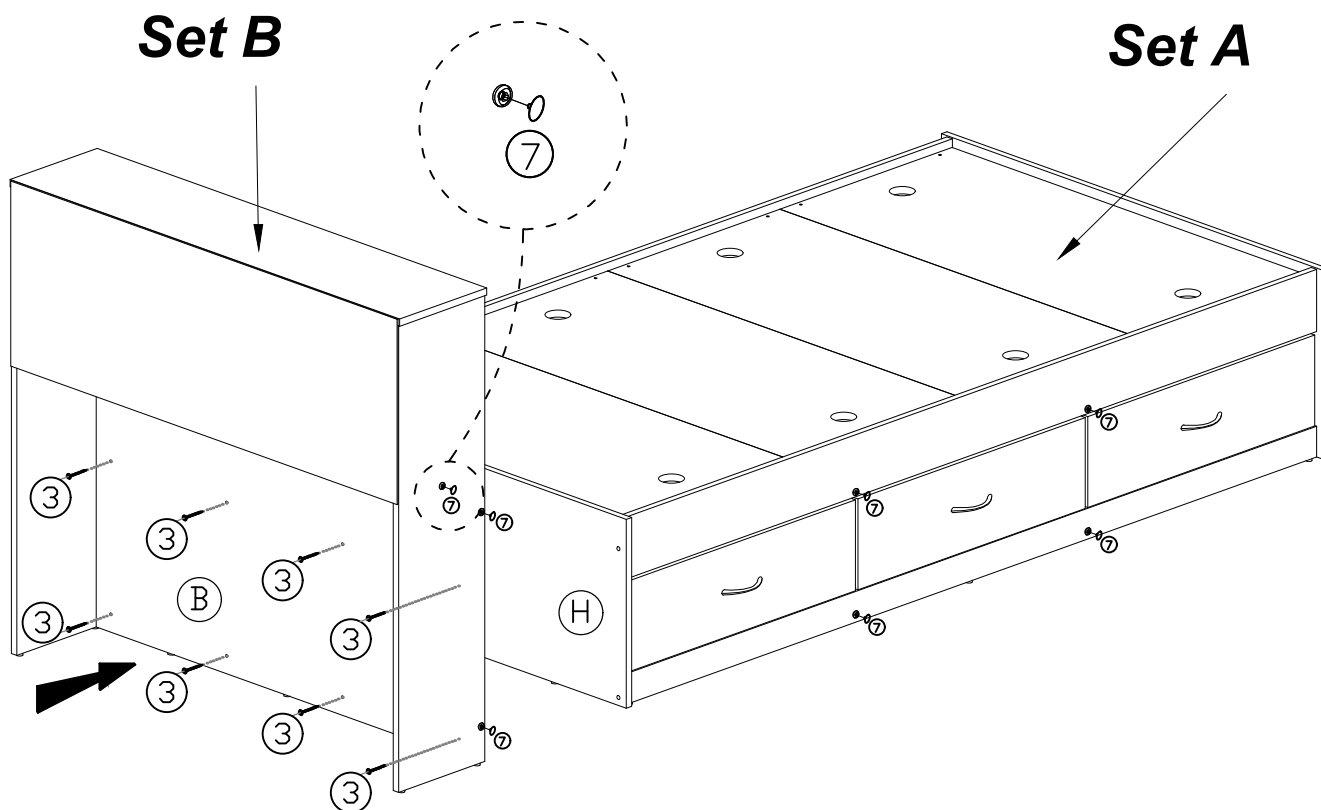

HODEDAH®

Job Complete

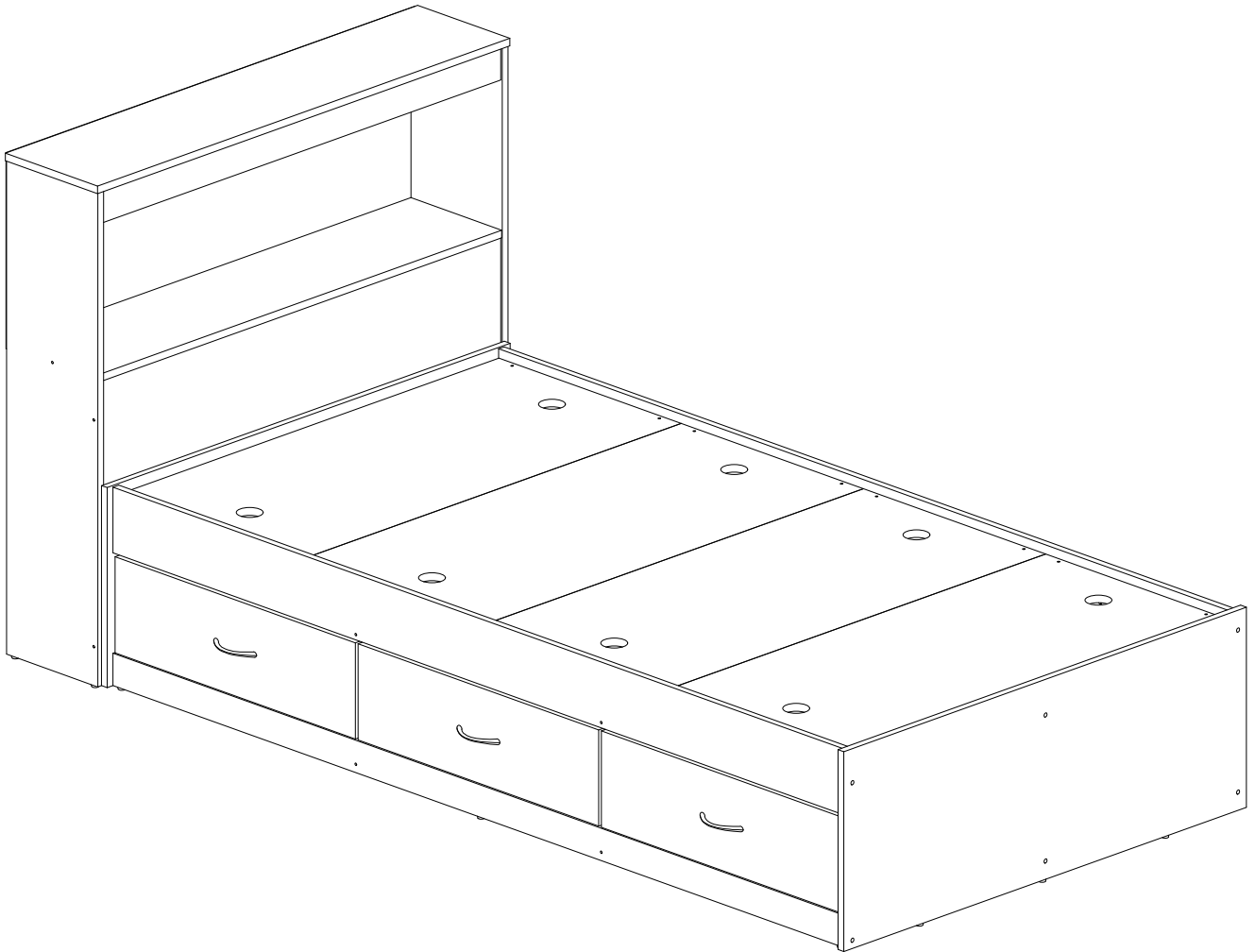

Enjoy & Thank you for purchasing from Hodedah!



In the interest of our environment please dispose of all packaging thoughtfully.