

OFFICE CHAIR

ASSEMBLY GUIDE



Important - Please read these instructions fully before starting assembly



SAFETY AND CARE ADVICE



NO POWER TOOLS

SAFETY AND CARE ADVICE

- Check you have all the components and tools listed.
- Remove all fittings from the plastic bags and separate them into their groups.
- We do not recommend the use of power drills/drivers for inserting screws, as this could damage the unit. Only use hand screwdrivers and Allen keys.
- Keep children and animals away from the work area, small parts could cause choking if swallowed.
- Make sure you have enough space to lay out the parts before starting.
- Assemble the item as close to its final position (in the same room) as possible.
- Do not overtighten the nuts to avoid causing damage to the threads.
- Only clean using a damp cloth and mild detergent, do not use bleach or abrasive cleaners.
- From time to time check that there are no loose screws on this unit.
- This product should not be discarded with household waste. Take to your local authority waste disposal centre.

IMPORTANT INFORMATION



30 MINUTE
BUILD





TWO
PERSON



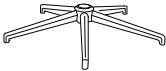
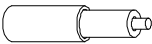

MAXIMUM
CAPACITY
110Kg

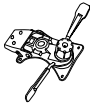
PLEASE CHECK CAREFULLY AND MAKE SURE YOU HAVE ALL FITTINGS AND TOOLS LISTED BELOW BEFORE YOU START.

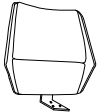
DESCRIPTION	PART NAME	QTY (PCS)
A		5
B		1
C		1

DESCRIPTION	PART NAME	QTY (PCS)
D		1
E		1
F		1

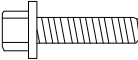
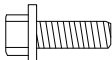
Parts for Chair Assembly

G		BOLT M8 x 28MM	4 PCS
H		BOLT M8 x 18MM	3 PCS
I		ALLEN KEY M5	1 PCS

NOTE: The quantities above are the correct amount to complete the assembly. In some cases more fittings may be supplied than are required.

STEP 1

Use a clean, flat, soft surface to avoid any bumps or scratches.

Carefully unpack your office chair.

Gently push 1 x castor [A] into each socket of the star base [B].

It should fit snugly without much force.

Insert 1 x gas lift [C] into the star base [B].

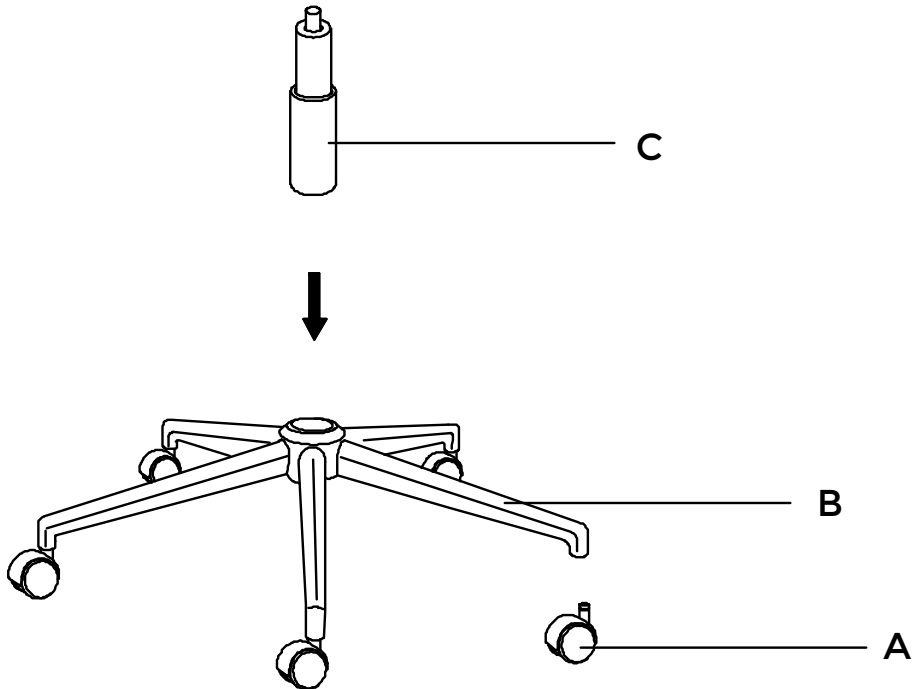

STEP 2

Carefully and with help, place your backrest [F] on a soft surface. Slide the mechanism [D] into the bracket of backrest [F].

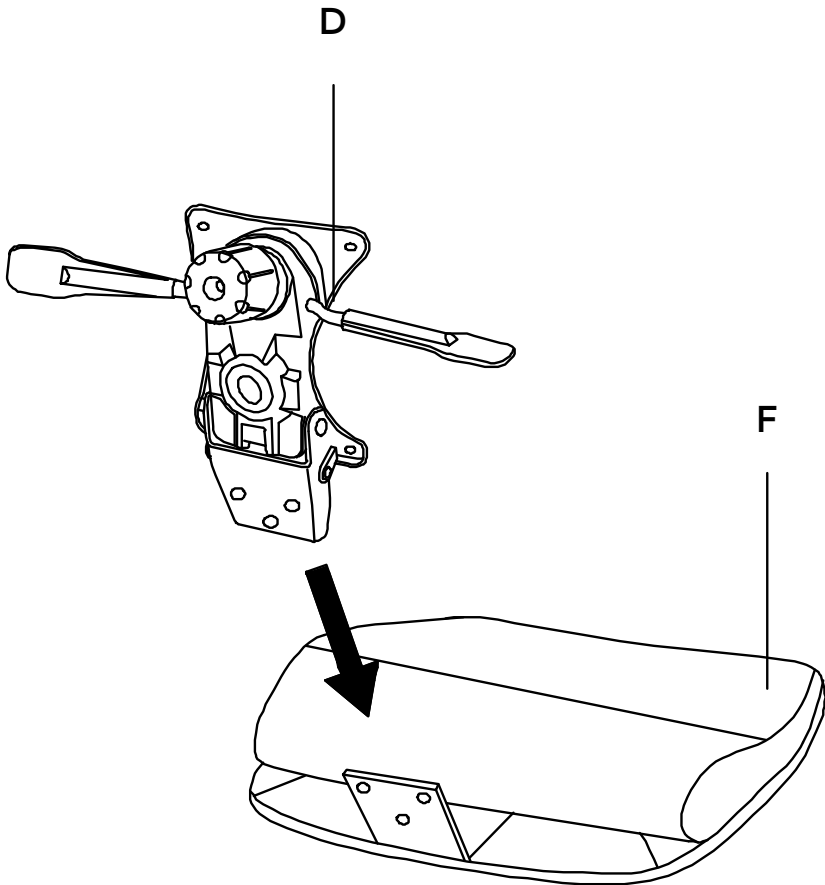

STEP 3

Secure the mechanism [D] with 3 x bolts [H].
Tighten using Allen key [I].

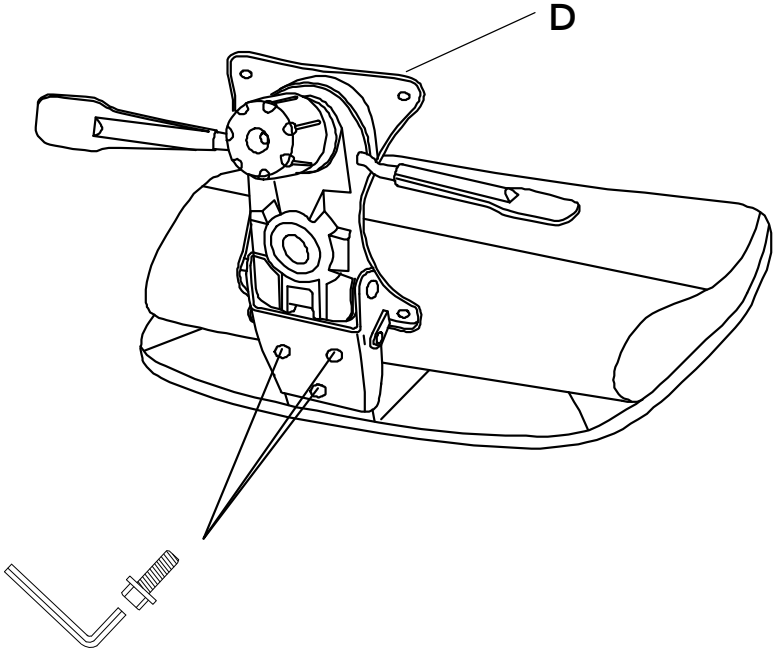

H		BOLT M8 x 18MM	4 PCS
I		ALLEN KEY M5	1 PCS

STEP 4

Place seat [E] on the backrest as shown, with the 'front' label on seat [E] above the mechanism [D].

Align seat [E] to the pre-drilled holes on the mechanism [D] and attach using 4 x bolts [G]. Tighten using Allen key [I].

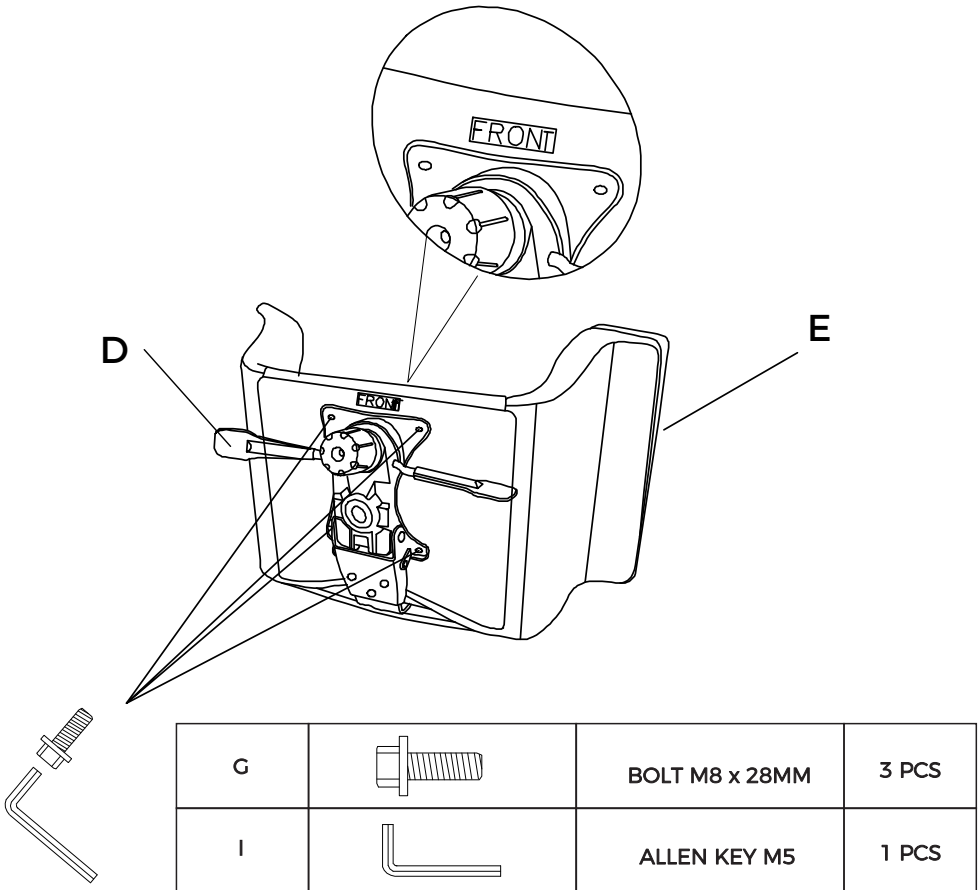

STEP 5

Carefully and with help, place the assembled seat onto the gas lift [C], making sure the gas lift [C] top is inserted into the hole on mechanism [D] as shown.

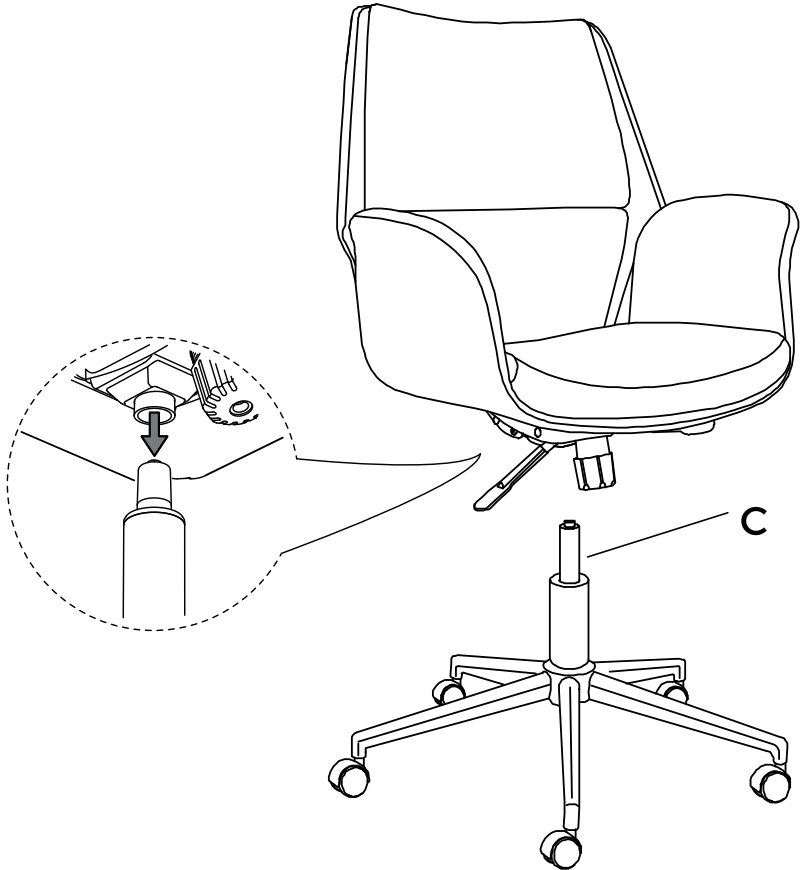

STEP 6

Your office chair is now complete, and ready to use !





OUR 2 YEAR GUARANTEE



WHAT THE GUARANTEE COVERS



PRE-INSERTED FIXINGS
e.g. loose metal threads



FAULTY JOINTS
e.g. legs bending



EXTERNAL FIXING FAULTS



STRUCTURAL INTEGRITY