

# QUEEN BED ASSEMBLY INSTRUCTIONS

## PARTS AND HARDWARE PACKING CONFIGURATIONS

### BOX #1

A. HEADBOARD: 1PC    B. LEGS : 2PCS    C. STRETCHER : 1 PC

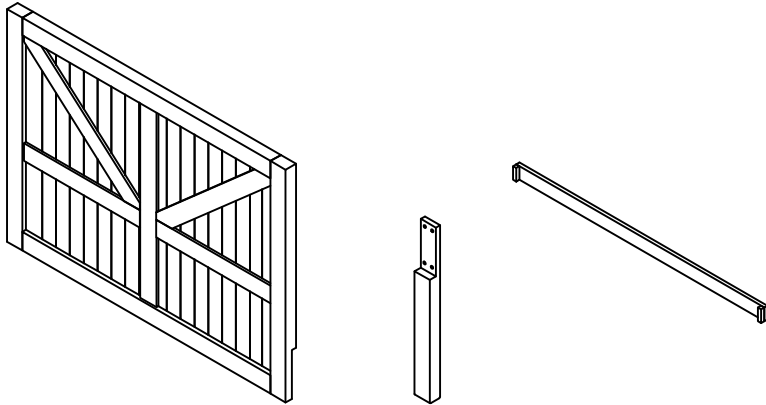

### BOX #2

D. FOOTBOARD: 1PC

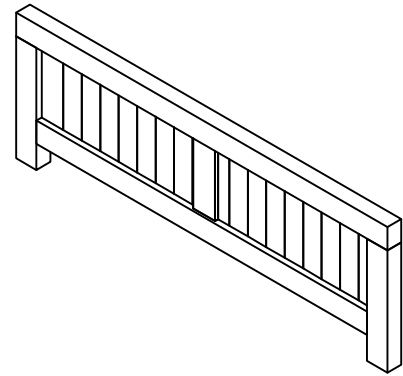

### BOX #3

E. SIDE RAILS: 2PCS

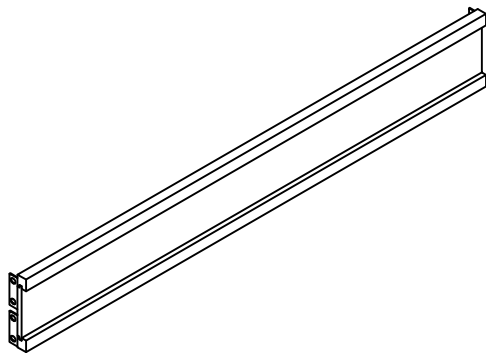

F. SLATS: 5PCS

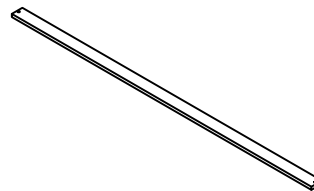

G. CENTER LEG 5 PCS

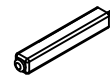

### BED ASSEMBLED

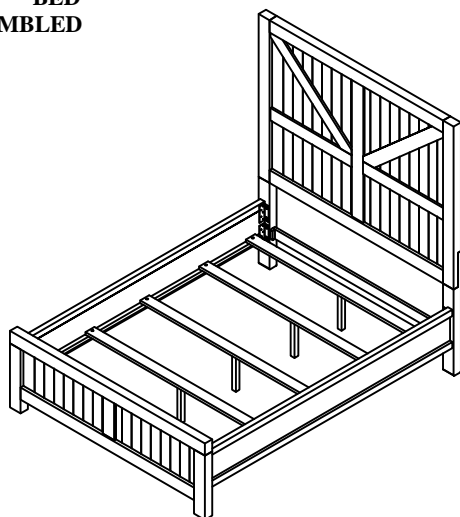

### HARDWARE PACKED IN BOX #3

1. ALLEN BOLT  
M8x50MM: 10PCS



2. ALLEN BOLT  
M8x30MM: 16PCS



3. SPRING WASHERS  
M8xØ12x1.7: 26PCS



4. FLAT WASHERS  
M8xØ19x1.7: 26PCS



5. SCREW  
M4x30MM: 10 PCS



6. ALLEN KEY  
M4 x 110: 1PC



# QUEEN BED ASSEMBLY INSTRUCTIONS

## STEP 1

ATTACH THE LEGS (B) TO THE HEADBOARD (A) USING FOUR M8X50 ALLEN BOLTS (1), SPRING WASHERS (3) AND FLAT WASHERS (4) PER LEG. DO NOT TIGHTEN COMPLETELY. ATTACH THE STRETCHER (C) TO THE LEGS WITH ONE M8X50 ALLEN BOLTS, SPRING AND FLAT WASHERS PER SIDE. TIGHTEN ALL TEN BOLTS WITH ALLEN KEY (6).

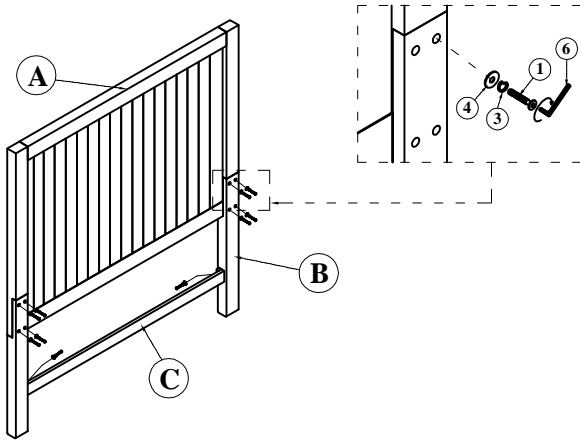

NO.	PICTURE	SIZE	QTY.
①		M8x50	10
③		M8xØ12xt1.7	10
④		M8xØ19xt1.7	10

## STEP 2

ATTACH THE SIDE RAILS (3) TO THE HEADBOARD AND FOOTBOARD (D). USE FOUR M8X30 ALLEN BOLTS, SPRING WASHERS AND FLAT WASHERS PER END; 8 BOLTS PER RAIL. DO NOT TIGHTEN COMPLETELY. REPEAT FOR SECOND RAIL THEN TIGHTEN ALL SIXTEEN BOLTS COMPLETELY.

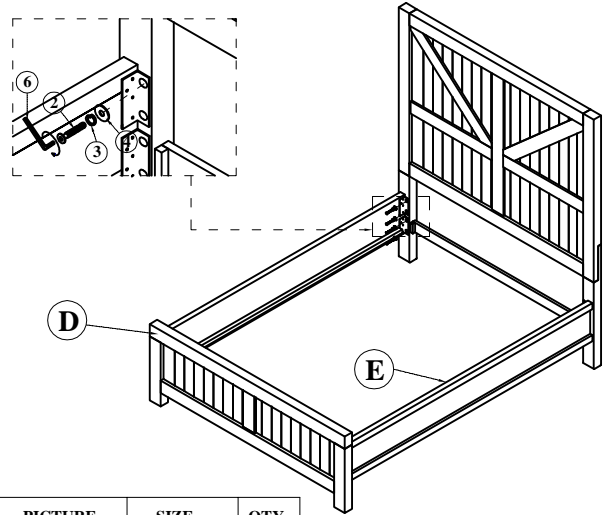

NO.	PICTURE	SIZE	QTY.
②		M8x30	16
③		M8xØ12xt1.7	16
④		M8xØ19xt1.7	16

## STEP 3

ATTACH THE CENTER LEG SUPPORTS (G) TO THE SLATS (F). FOLLOWING THE ILLUSTRATION, ATTACH THE SLATS TO THE BED USING WOOD SCREWS (5). NOTE THAT THE SCREW DRIVER IS NOT INCLUDED.

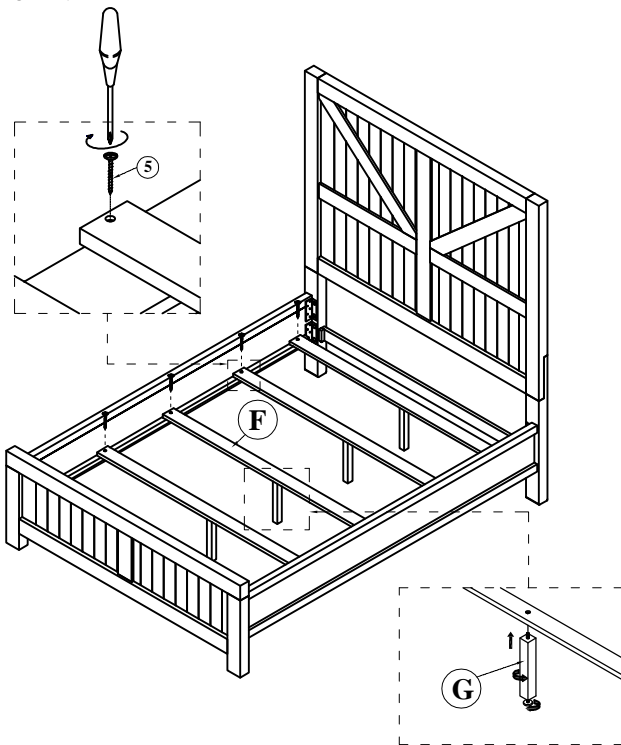

NO.	PICTURE	SIZE	QTY.
⑤		M4x30	10

## STEP 4

**ASSEMBLY COMPLETED**

