

ASSEMBLY INSTRUCTION

PATIO DOUBLE LOUNGE

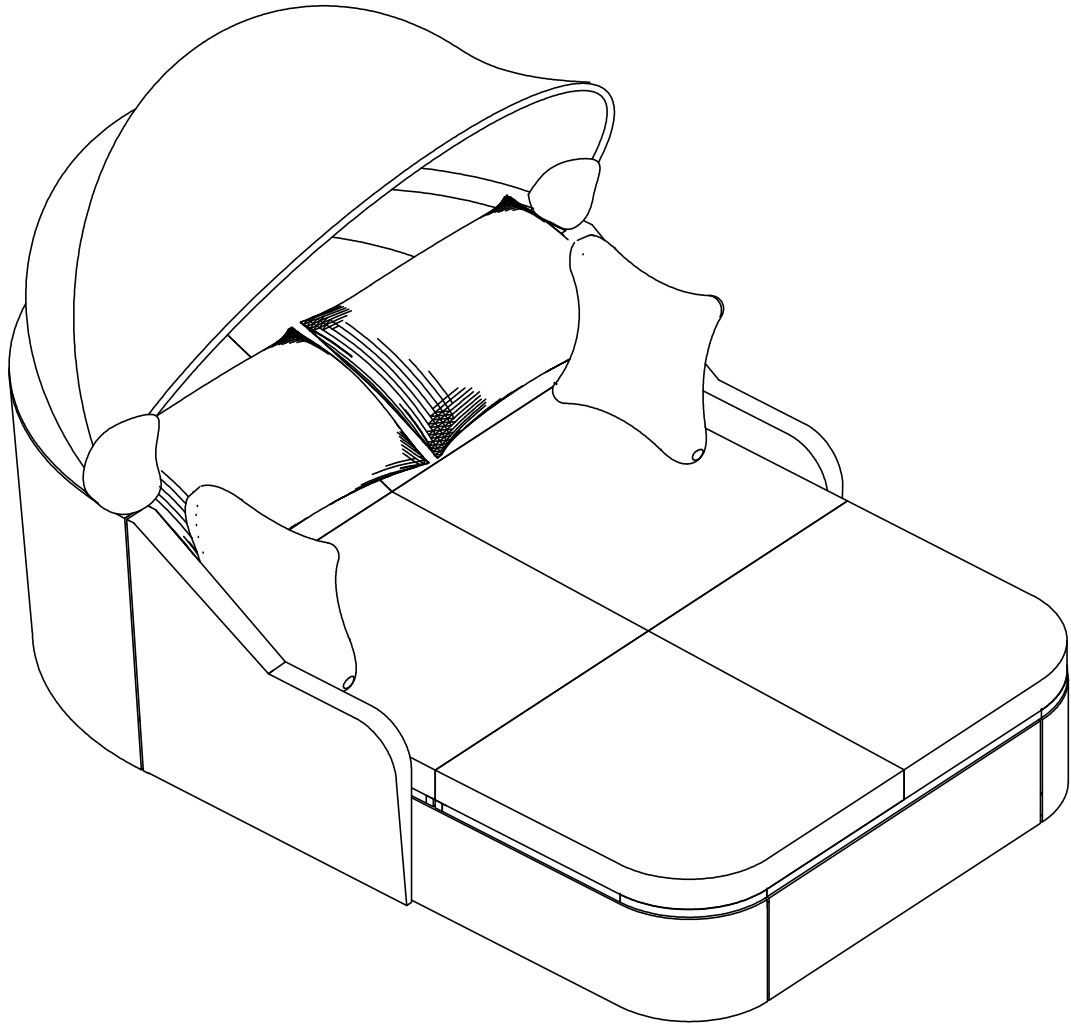

Before installation, insert the screws into the holes and tighten them, but do not tighten them to 100%, 70% to 80% is sufficient. Finally, after all screws are installed, tighten all screws to 100%. If you encounter these issues, such as if the holes cannot be aligned or some parts cannot be installed, please check if the screws are used correctly and adjust the tightness of the screws.



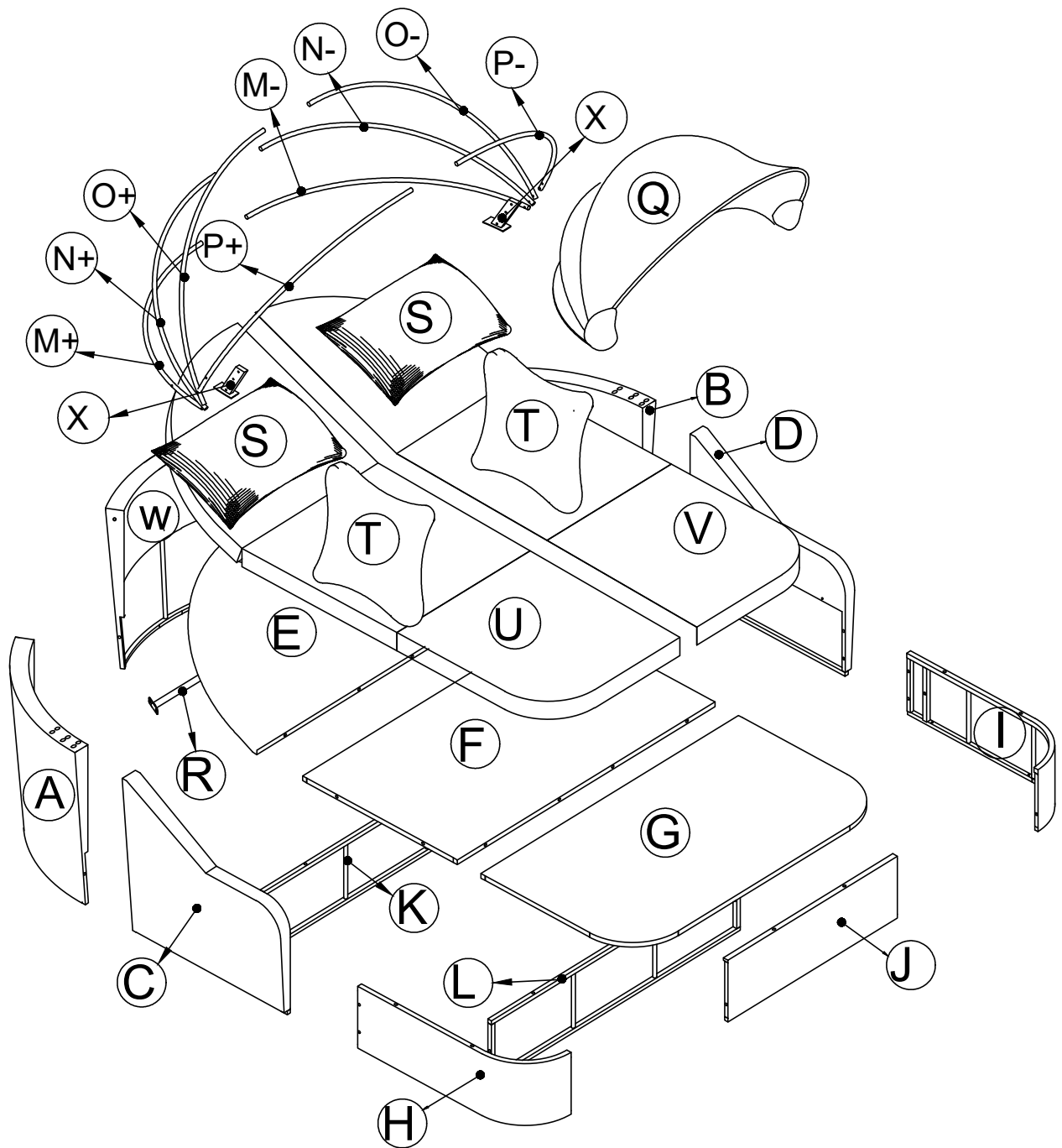





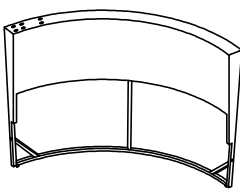
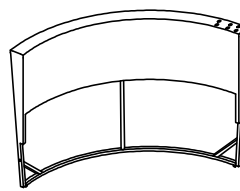
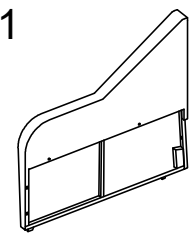
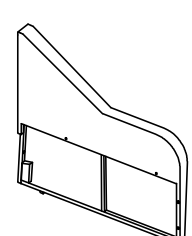
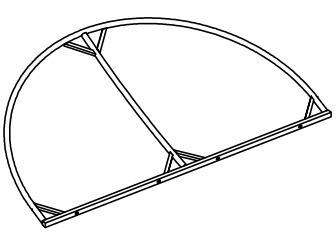
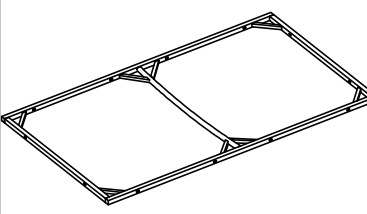
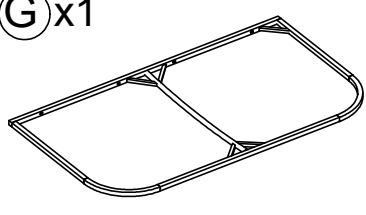
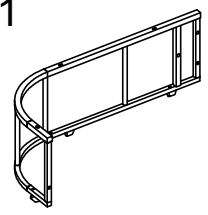
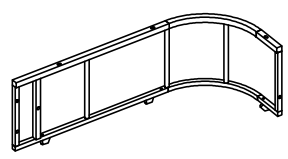
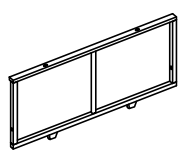
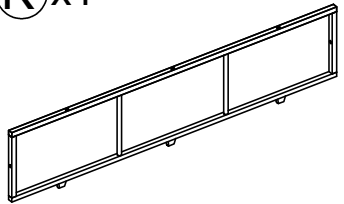
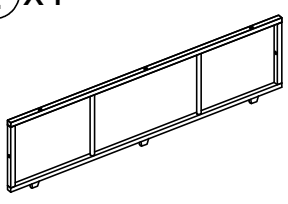
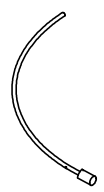

X1



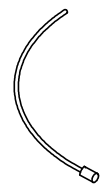



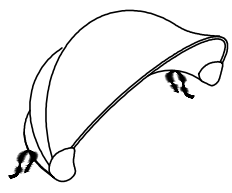
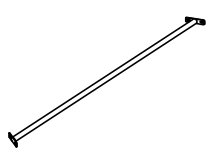
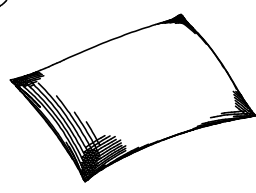

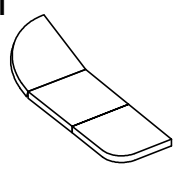
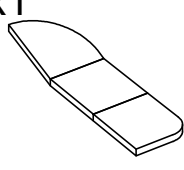
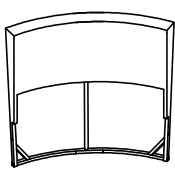
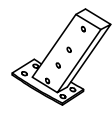

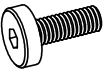
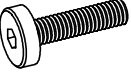
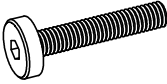
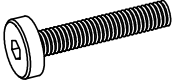

Note:

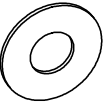
1. 50% Tighten before fixing all screws, Allen wrench is recommended instead of an electric drill.
2. Place the item on a flat ground to adjust and make sure it remains stable.
3. Tighten up all screw with tools gradually.
4. If screw are not aligned with holes during assembly, please loosen all the other screws to 50% and continue the assembly process.
5. If the item is not stable, please loosen all screws, adjust it on a flat ground and tighten up all screws again.
6. Note: If one or some screws are fully tighten during assembly, chances are the others will not be aligned with holes. In addition, all the holes are designed to be relatively larger to provide more space for the adjustment of the screws.

Part List:

<p>Ax1</p>  <p>Back Right</p>	<p>Bx1</p>  <p>Back Left</p>	<p>Cx1</p>  <p>Arm Right</p>	<p>Dx1</p>  <p>Arm Left</p>	
<p>Ex1</p>  <p>Front Seat Lounge</p>	<p>Fx1</p>  <p>Middle Seat Lounge</p>	<p>Gx1</p>  <p>Behind Seat Lounge</p>	<p>Hx1</p>  <p>Side Right Lounge</p>	
<p>Ix1</p>  <p>Side Left Lounge</p>	<p>Jx1</p>  <p>Front Lounge</p>	<p>Kx1</p>  <p>Front Bare</p>	<p>Lx1</p>  <p>Middle Bare</p>	
<p>M+x1</p>  <p>Support M+</p>	<p>M-x1</p>  <p>Support M-</p>	<p>N+x1</p>  <p>Support N+</p>	<p>N-x1</p>  <p>Support N-</p>	
<p>O+x1</p>  <p>Support O+</p>	<p>O-x1</p>  <p>Support O-</p>	<p>P+x1</p>  <p>Support P+</p>	<p>P-x1</p>  <p>Support P-</p>	
<p>Qx1</p>  <p>Covered</p>	<p>Rx1</p>  <p>Support Back</p>	<p>Sx2</p>  <p>Back Cushion</p>	<p>Tx2</p>  <p>Pillow Cushion</p>	
<p>Ux1</p>  <p>Seat Cushion Right</p>	<p>Vx1</p>  <p>Seat Cushion Left</p>	<p>Wx1</p>  <p>Back Middle</p>	<p>Xx2</p>  <p>CONNECTION A</p>	

Hardware List:

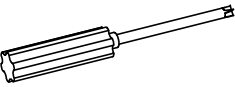
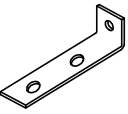
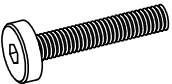
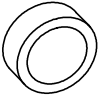
<p>① x 16 pcs Extra 2 pcs</p>  <p>BOLT M6 x 20MM</p>	<p>② x 2 pcs Extra 1 pcs</p>  <p>BOLT M6 x 25MM</p>	<p>③ x 12 pcs Extra 2 pcs</p>  <p>BOLT M6 x 30MM</p>	<p>④ x 20 pcs Extra 2 pcs</p>  <p>BOLT M6 x 35MM</p>
<p>⑤ x 8 pcs Extra 1 pcs</p>  <p>BOLT M6 x 60MM</p>	<p>⑥ x 84 pcs Extra 5 pcs</p>  <p>FLAT WASHER M6</p>	<p>⑦ x 10 pcs Extra 2 pcs</p>  <p>WASHER M6 x 5MM</p>	<p>⑧ x 2 pcs Extra 1 pcs</p>  <p>WASHER M6 x 10MM</p>
<p>⑨ x 18 pcs Extra 2 pcs</p>  <p>NUT M6</p>	<p>⑩ x 10 pcs Extra 2 pcs</p>  <p>COVER NUT M6</p>	<p>⑪ x 1 pc</p>  <p>KEY</p>	<p>⑫ x 2 pcs</p>  <p>ALLEN KEY</p>
<p>⑬ x 2 pcs</p>  <p>GASLIFT</p>	<p>⑭ x 4 pcs Extra 1 pcs</p>  <p>SCREW</p>	<p>⑮ x 1 pc</p>  <p>SCREW DIVER</p>	<p>⑯ x 2 pcs</p>  <p>CONNECTION</p>
<p>⑰ x 8 pcs Extra 1 pcs</p>  <p>BOLT M6 x 45MM</p>	<p>⑱ x 12 pcs Extra 2 pcs</p>  <p>COVER</p>		



BOLT
M6x20 MM

1

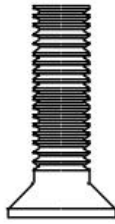

BOLT
M6x25 MM

2



BOLT
M6x30 MM

3



BOLT
M6x35 MM

4



BOLT
M6x60 MM

5



SCREW

14



BOLT
M6x45 MM

17

Please note that the shapes of screws 1 and 2 and 3 are similar.
Please install according to the instructions and distinguish them!

CARTON CONTENT

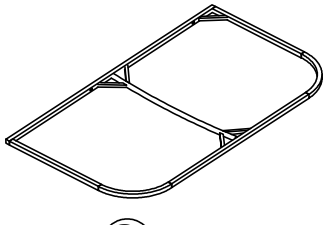

G x1

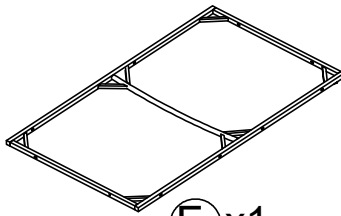

F x1

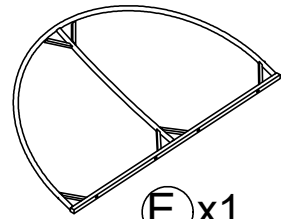

E x1

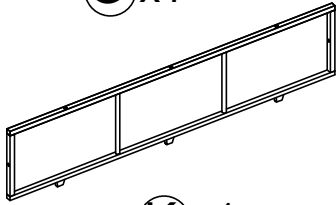

K x1

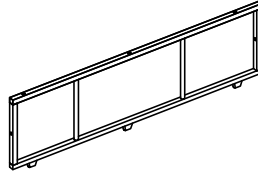

L x1



Q x1

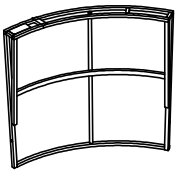

A x1

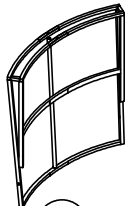

W x1

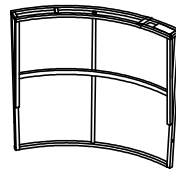

B x1

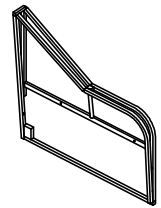

C x1

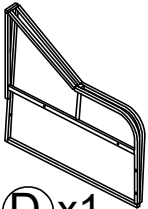

D x1

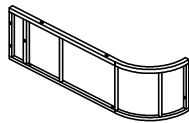

H x1

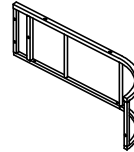

I x1



X x2

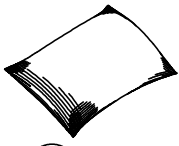

S x2



T x2

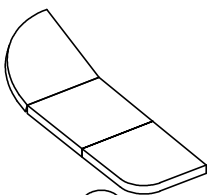

U x1

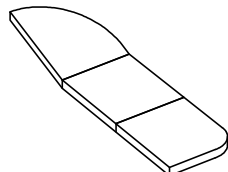

V x1

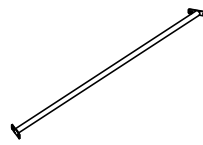

R x1

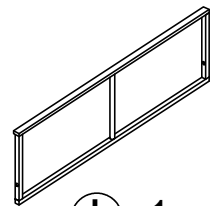

J x1



M+ x1



M- x1



N+ x1



N- x1



P+ x1



P- x1



N+ x1



N- x1

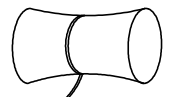

Hardware

STEP 1

W x 1

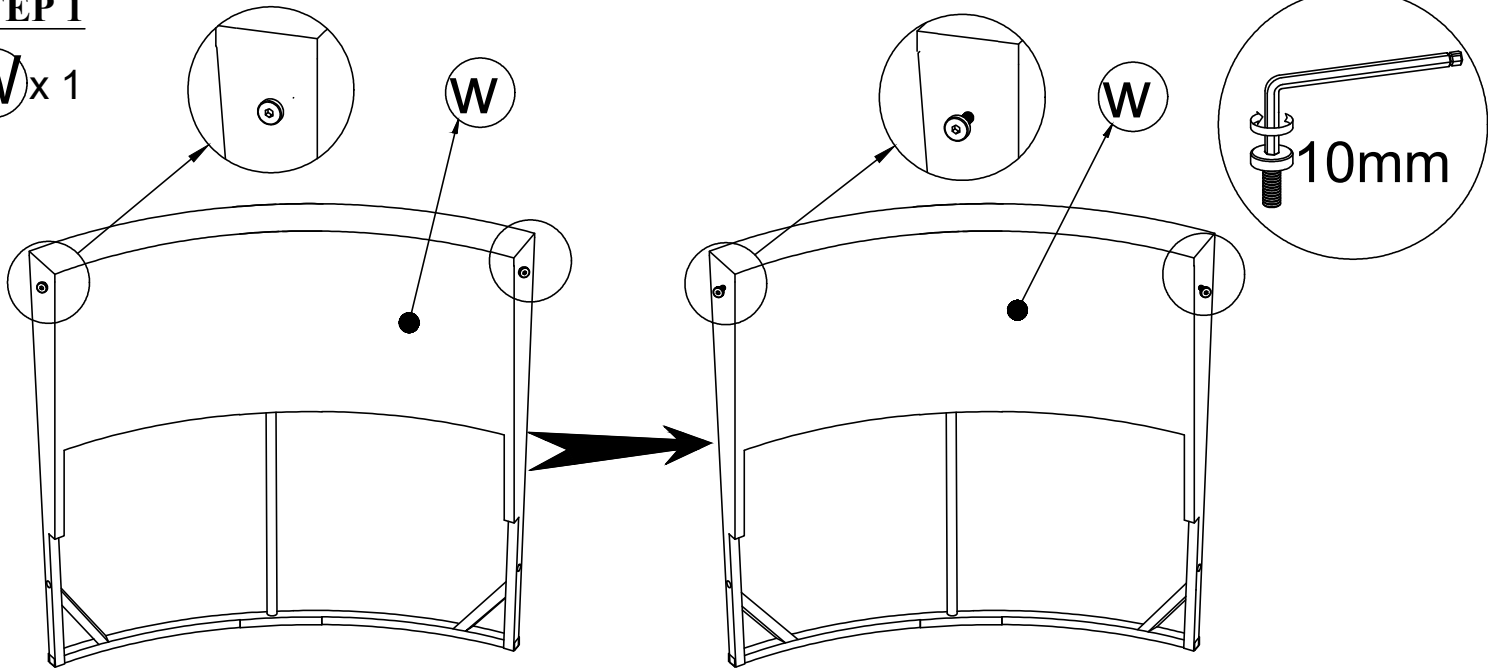

Use Allen key to loosen Bolt on the side of Back Middle (W) about 10 mm.

STEP 2

A x 1

B x 1

4 x 2

6 x 2

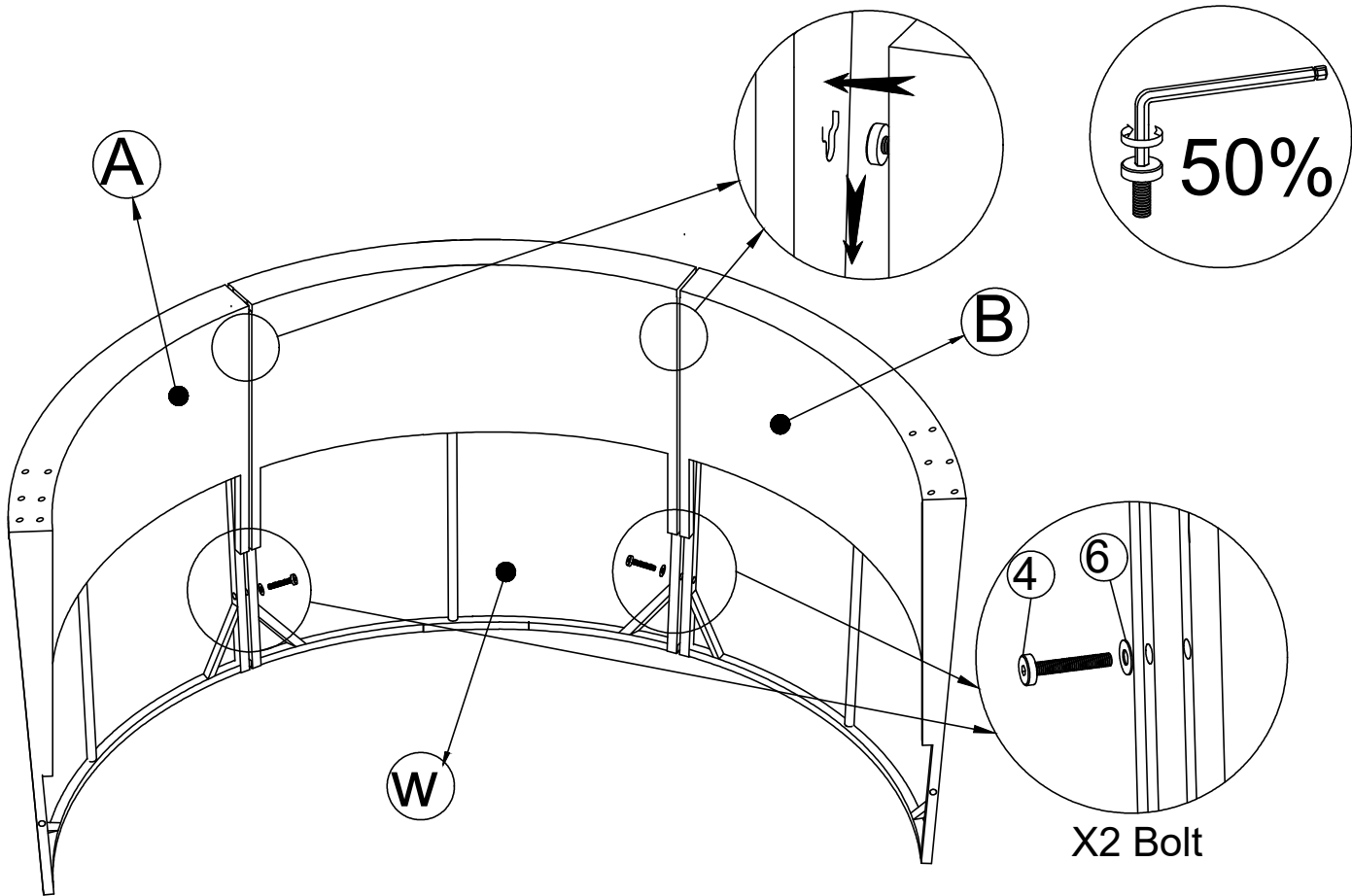

Connect The Part from Step 1 & Back Right (A), Back Left (B), tighten Bolt (4), Flat Washer (6) with Allen Key (12).

STEP 3

(R) x 1

(1) x 4

(6) x 4

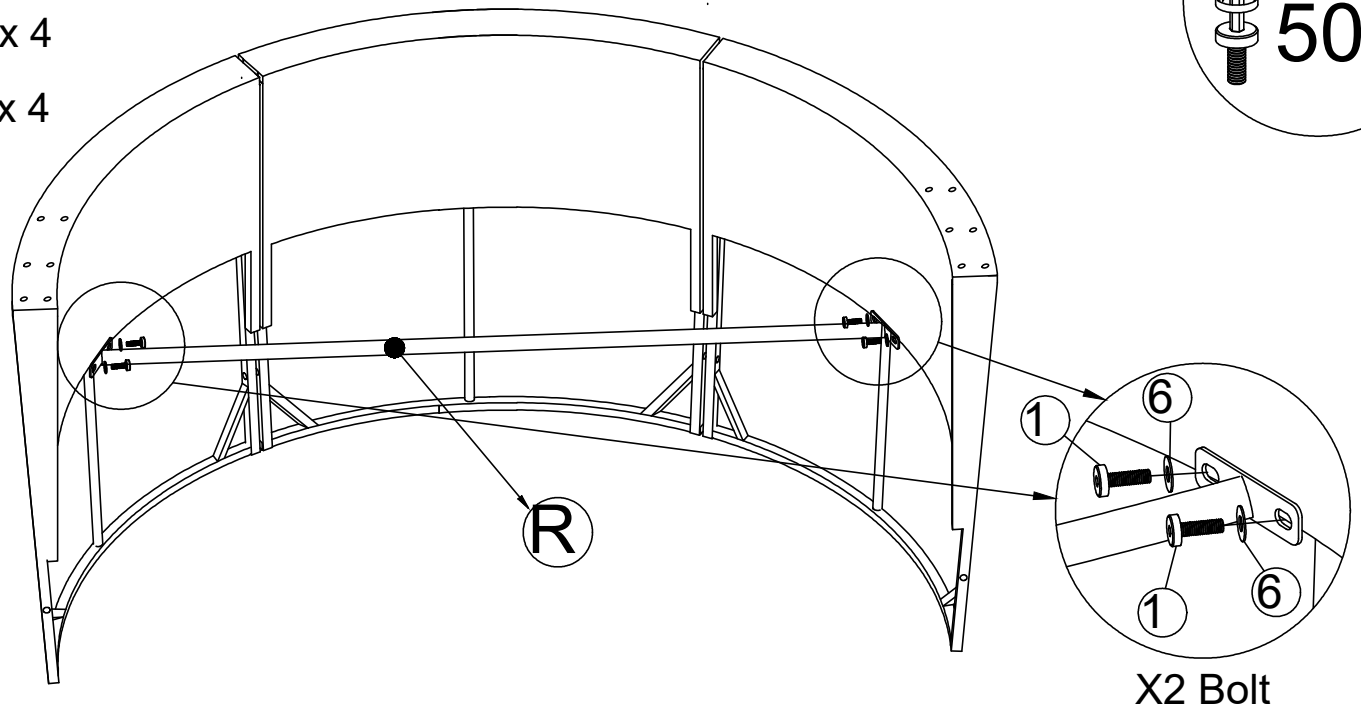
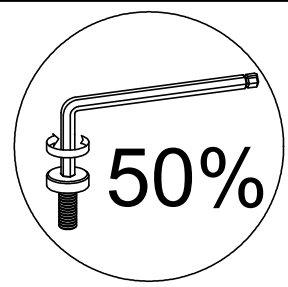

Connect The Part from Step 2 & Support Back (R), tighten Bolt (1), Flat Washer (6) with Allen Key (12).

STEP 4

(G) x 1

(H) x 1

(4) x 2

(6) x 2

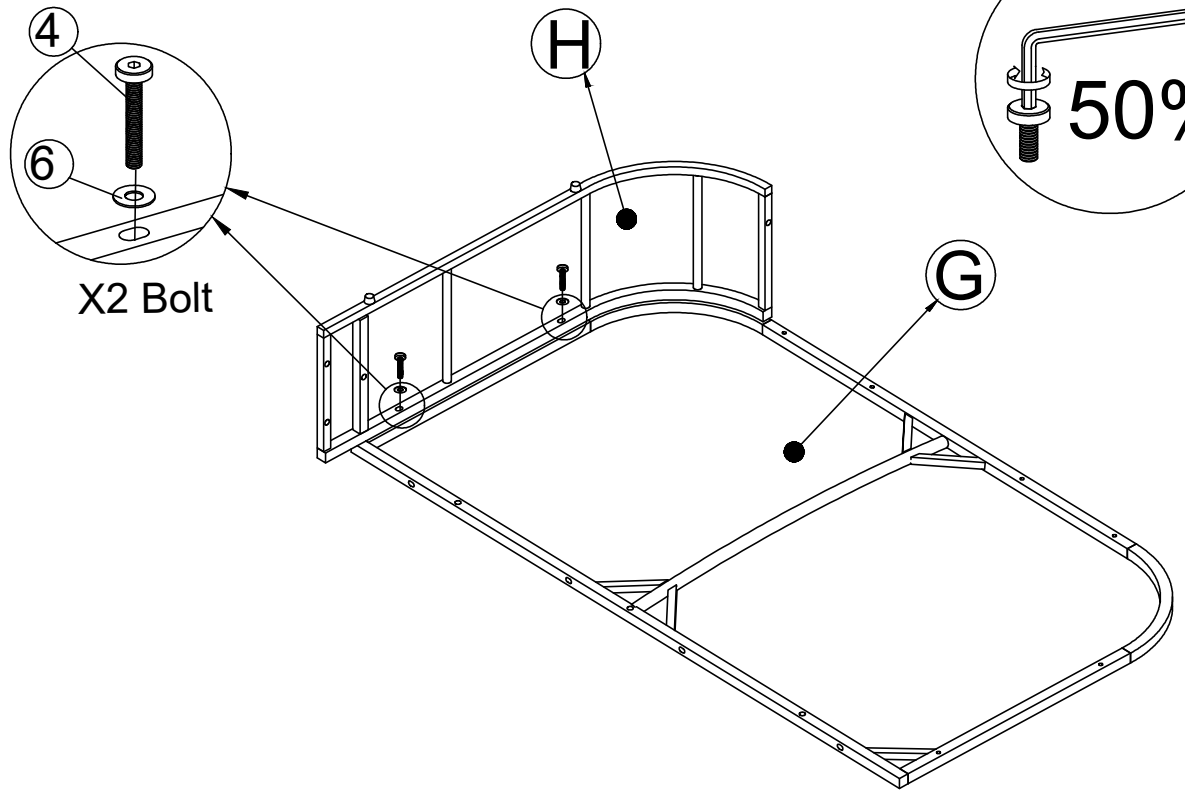
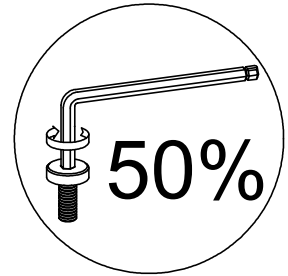

Connect Behind Seat Lounge(G) & Side Right Lounge (H), tighten Bolt (4), Flat Washer (6) with Allen Key (12).

STEP 5

- 1** x 1
- 4** x 2
- 6** x 2

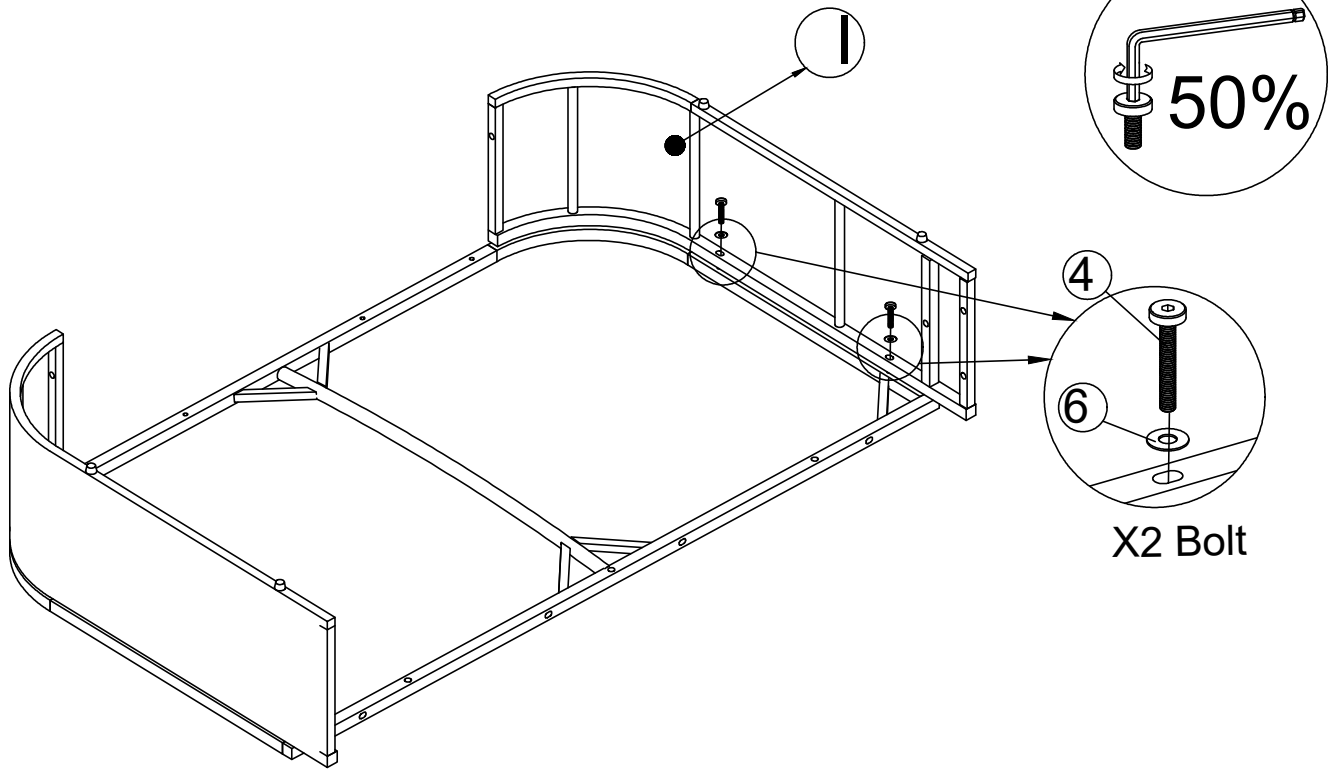

Connect The Part from Step 4 & Side Left Lounge (1), tighten Bolt (4), Flat Washer (6) with Allen Key (12).

STEP 6

- J** x 1
- 3** x 2
- 4** x 2
- 6** x 4

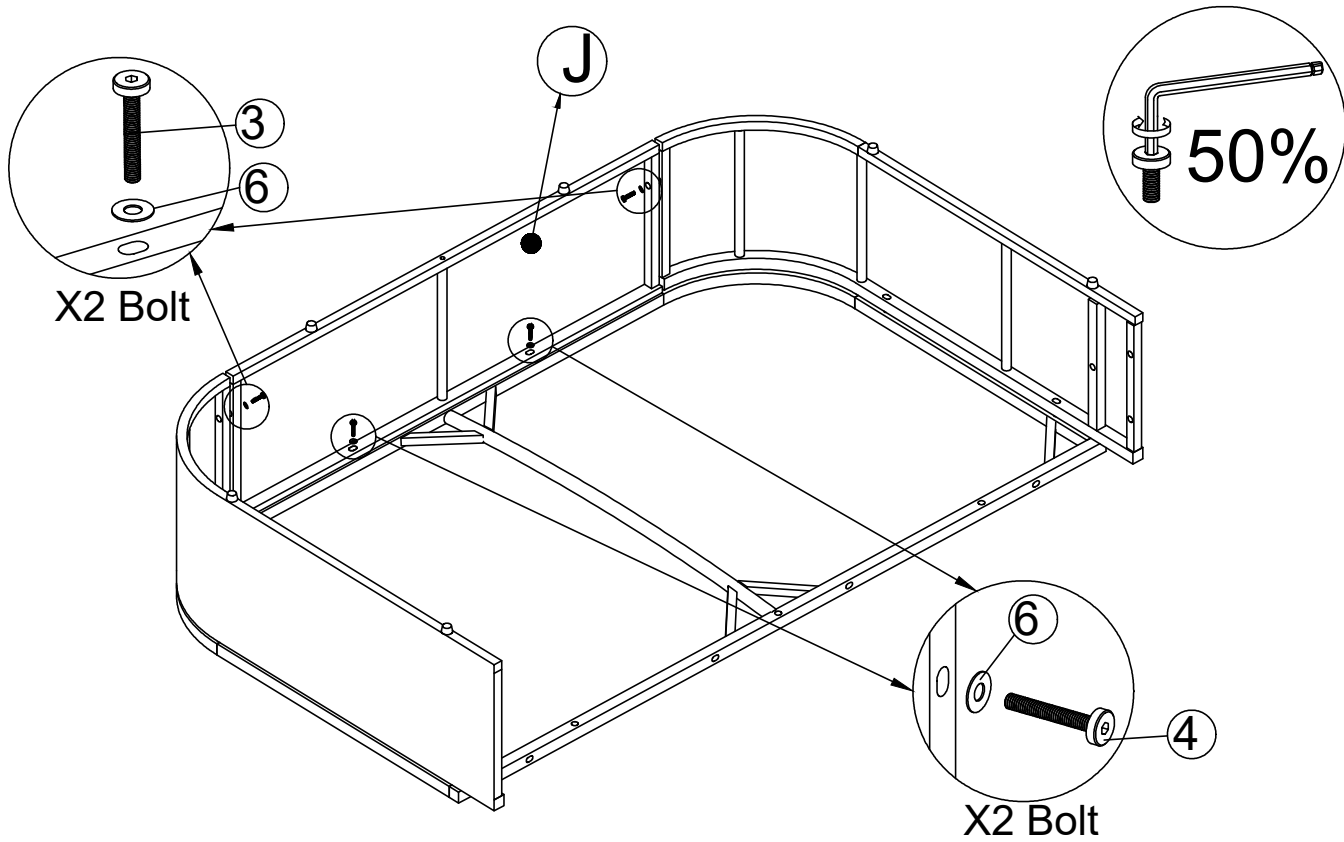

Connect The Part from Step 5 & Front Lounge (J), tighten Bolt (3), Bolt (4), Flat Washer (6) with Allen Key (12).

STEP 7

- L** x 1
- 3** x 2
- 4** x 3
- 6** x 5

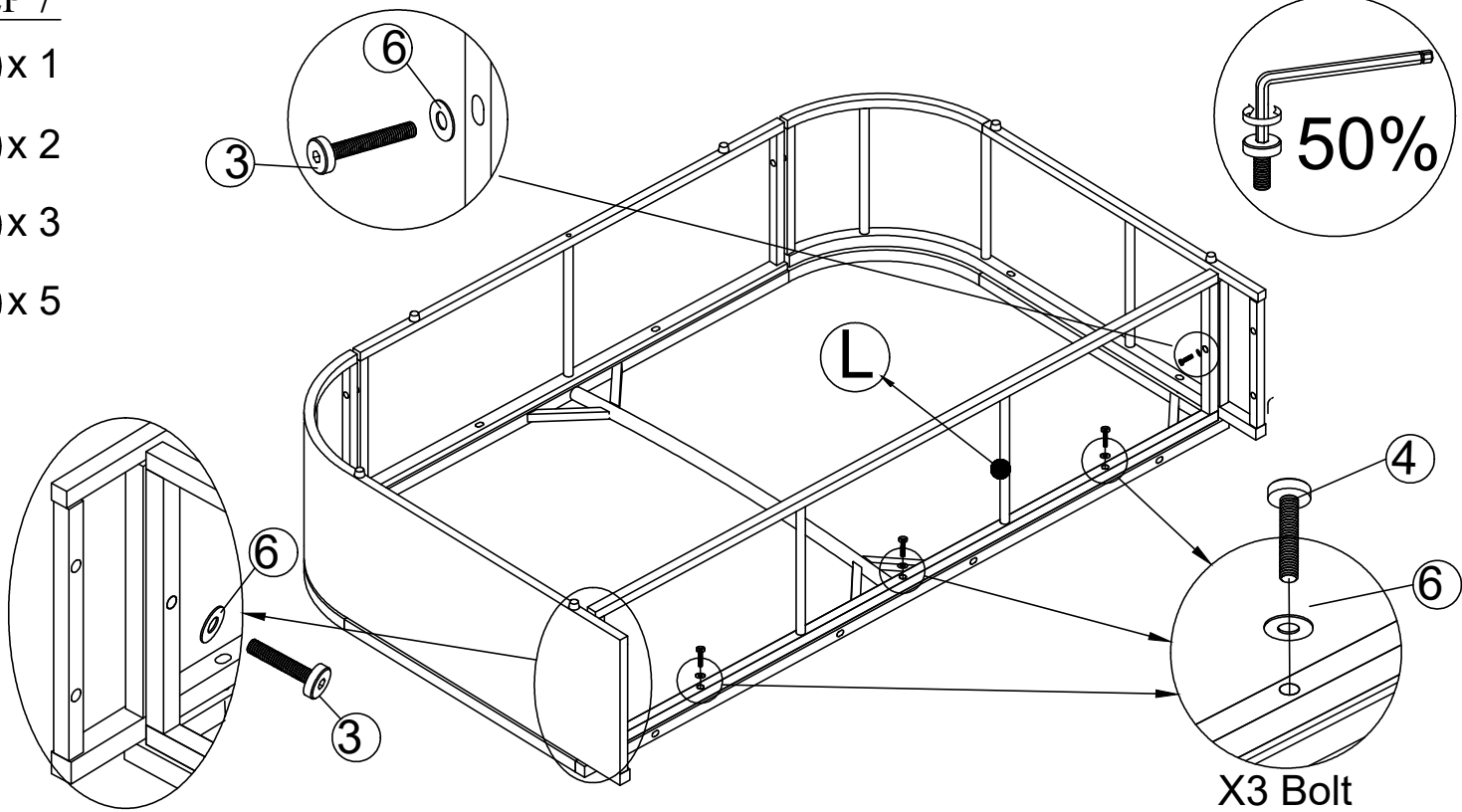

Connect The Part from Step 6 & Middle Bare (L), tighten Bolt (3) Bolt (4), Flat Washer (6) with Allen Key (12).

STEP 8

- F** x 1
- 5** x 4
- 6** x 8
- 9** x 4

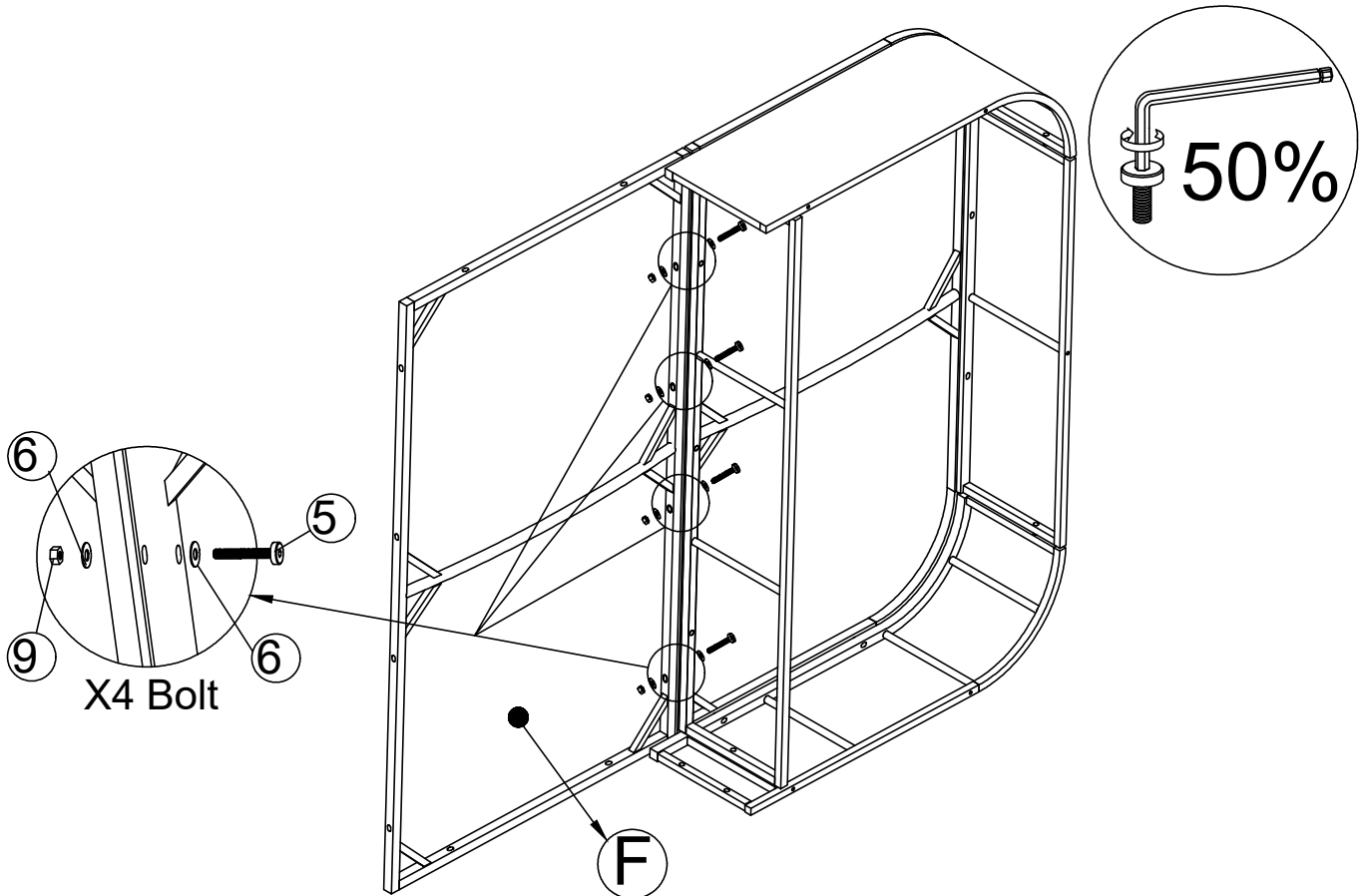

Connect The Part from Step 7 & Middle Seat Lounge (F), tighten Bolt (5), Flat Washer (6), Nut (9) with Allen Key (12), Key (11).

STEP 9

(C) x 1

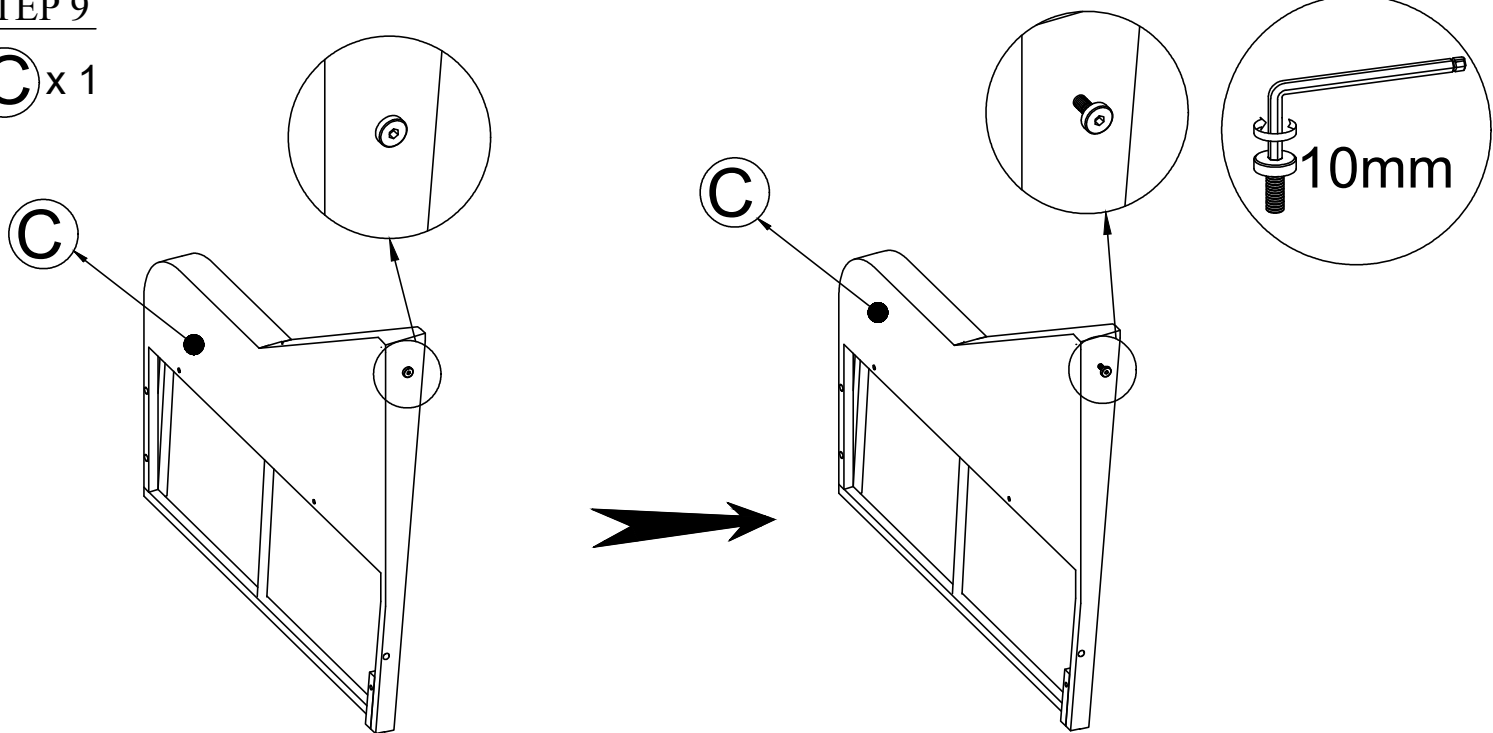

Use Allen key to loosen Bolt on the side of Arm Right (C) about 10 mm.

STEP 10

(D) x 1

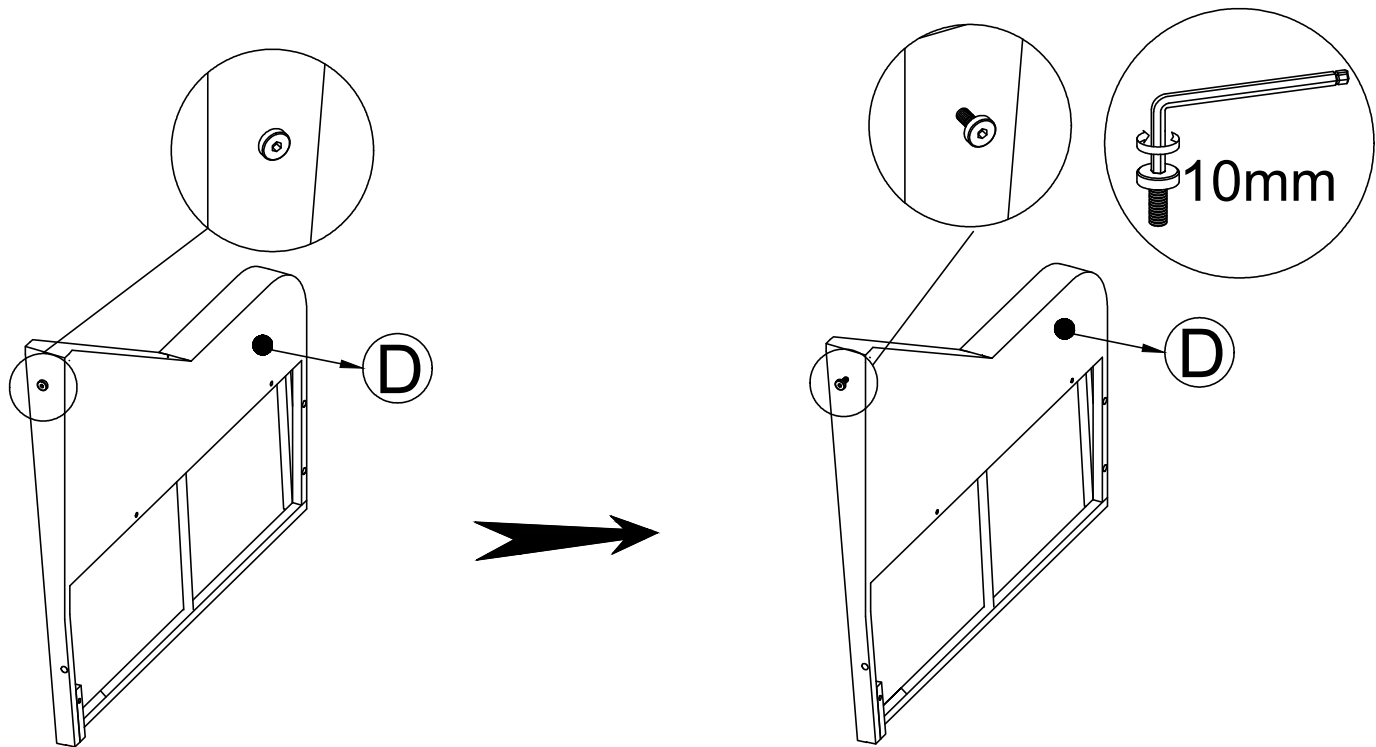

Use Allen key to loosen Bolt on the side of Arm Left (D) about 10 mm.

STEP 11

- D** x 1
- 3** x 2
- 4** x 2
- 6** x 4

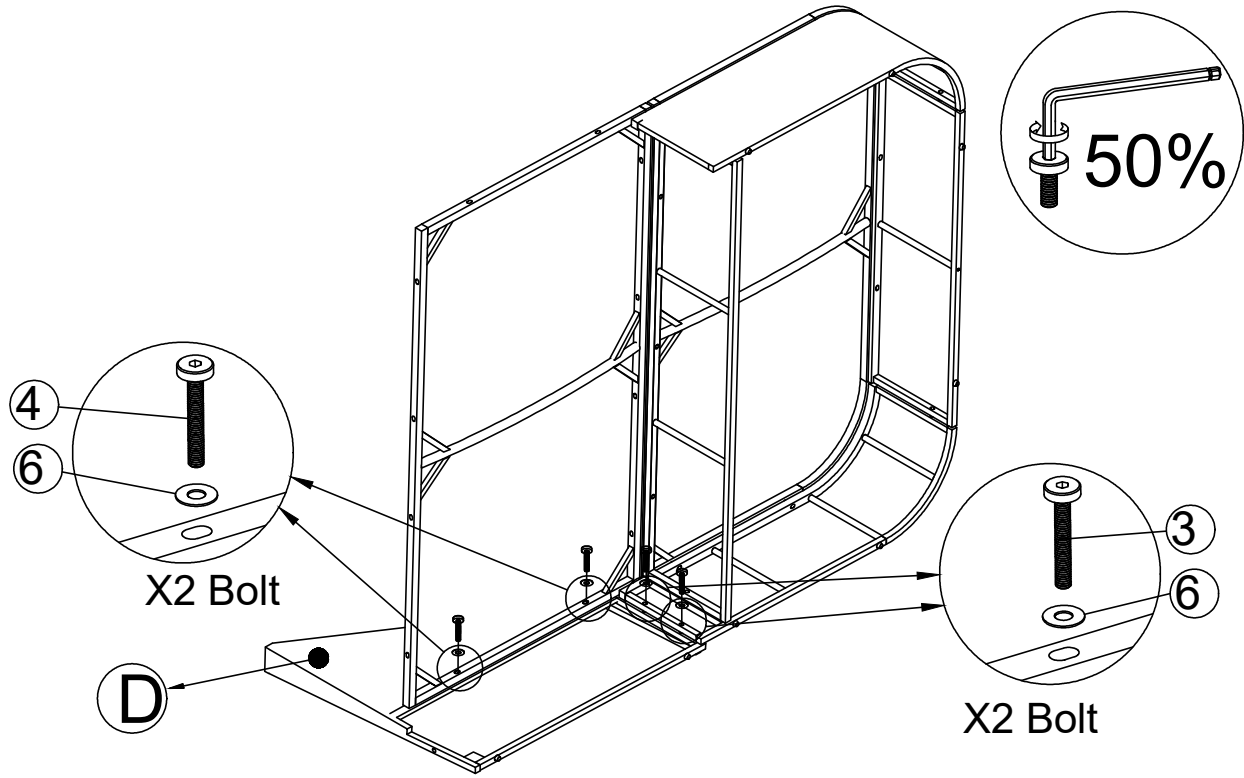

Connect The Part from Step 8 & Part from Step 10, tighten Bolt (3), Bolt (4) Flat Washer (6) with Allen Key (12).

STEP 12

- C** x 1
- 3** x 2
- 4** x 2
- 6** x 4

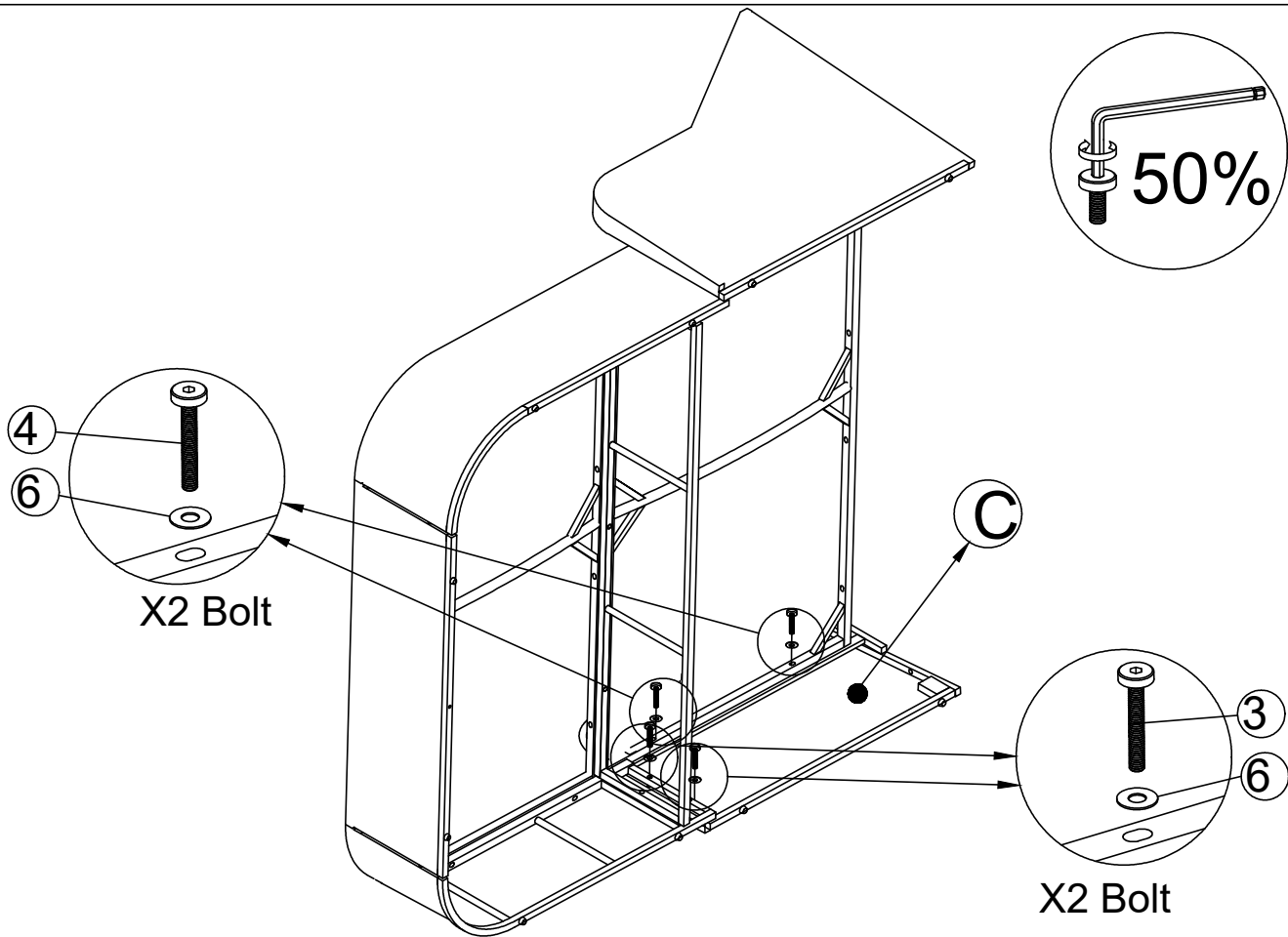

Connect The Part from Step 11 & Part from Step 9, tighten Bolt (3), tighten Bolt (4), Flat Washer (6), with Allen Key (12).

STEP 13

- (E)** x 1
- (5)** x 4
- (6)** x 8
- (9)** x 4

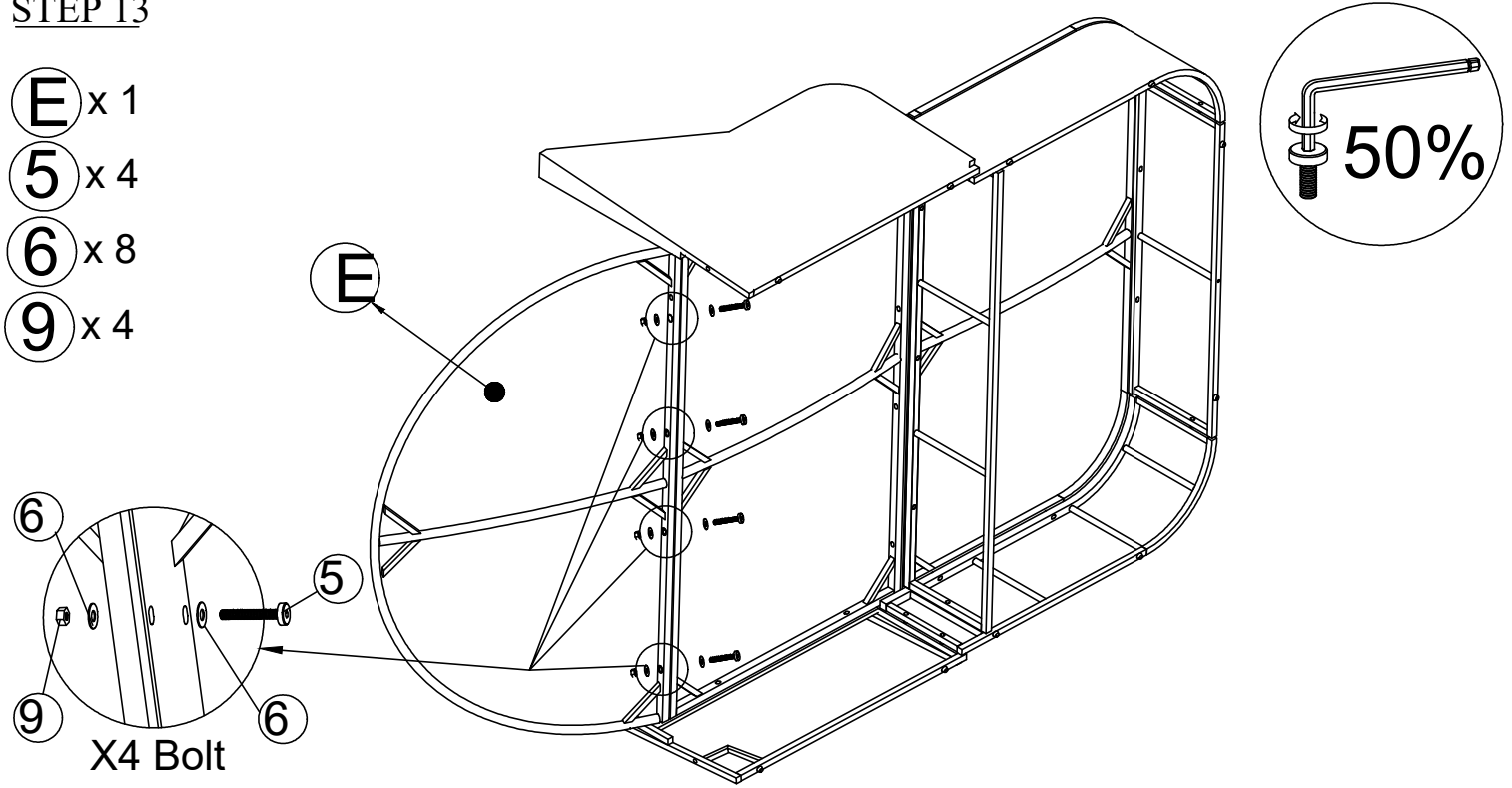

Connect The Part from Step 12 & Front Seat Lounge (E), tighten Bolt (5), Flat Washer (6) with Allen Key (12), Key (11).

STEP 14

- (K)** x 1
- (4)** x 3
- (3)** x 2
- (6)** x 5

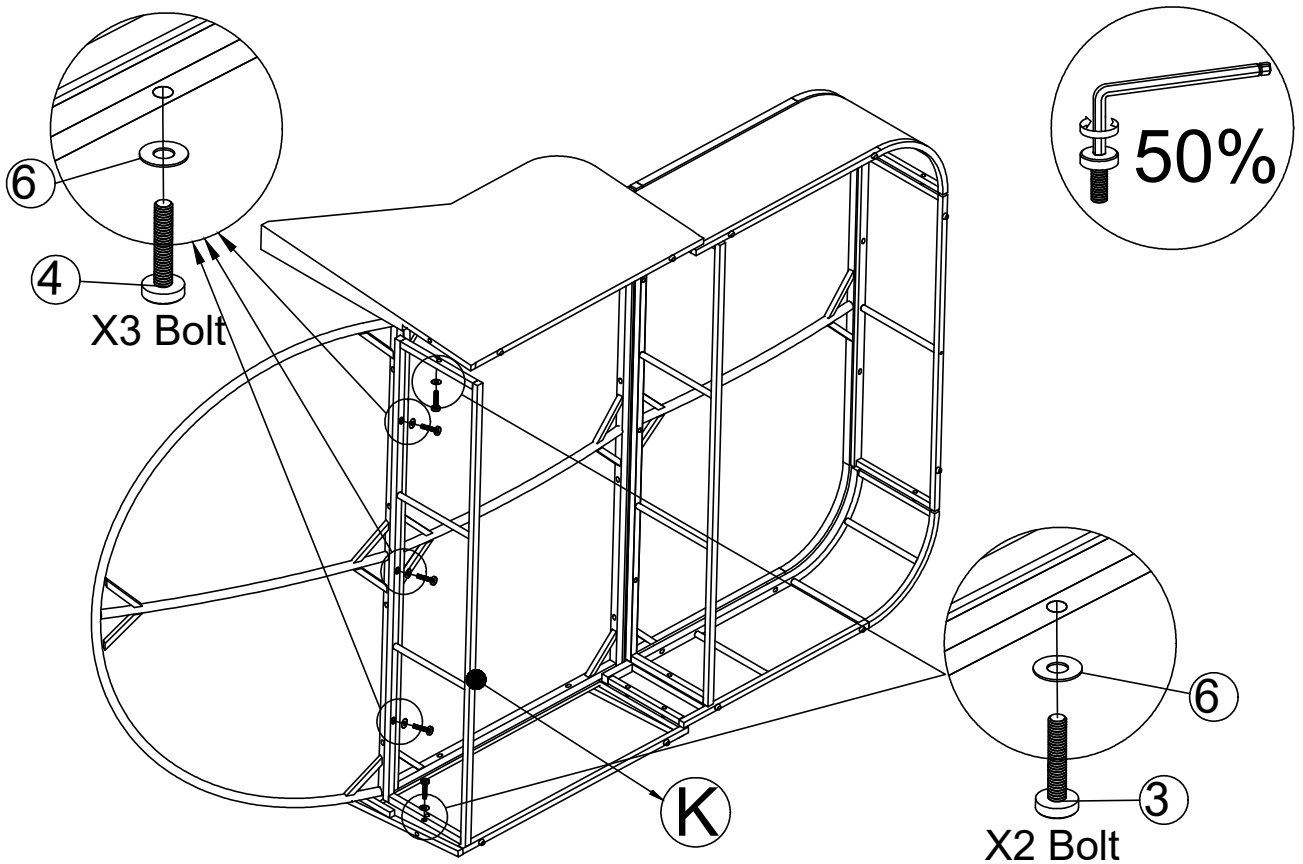

Connect The Part from Step 13 & Front Bare (K) tighten Bolt (3), Bolt (4), Flat Washer (6) with Allen Key (12).

STEP 15

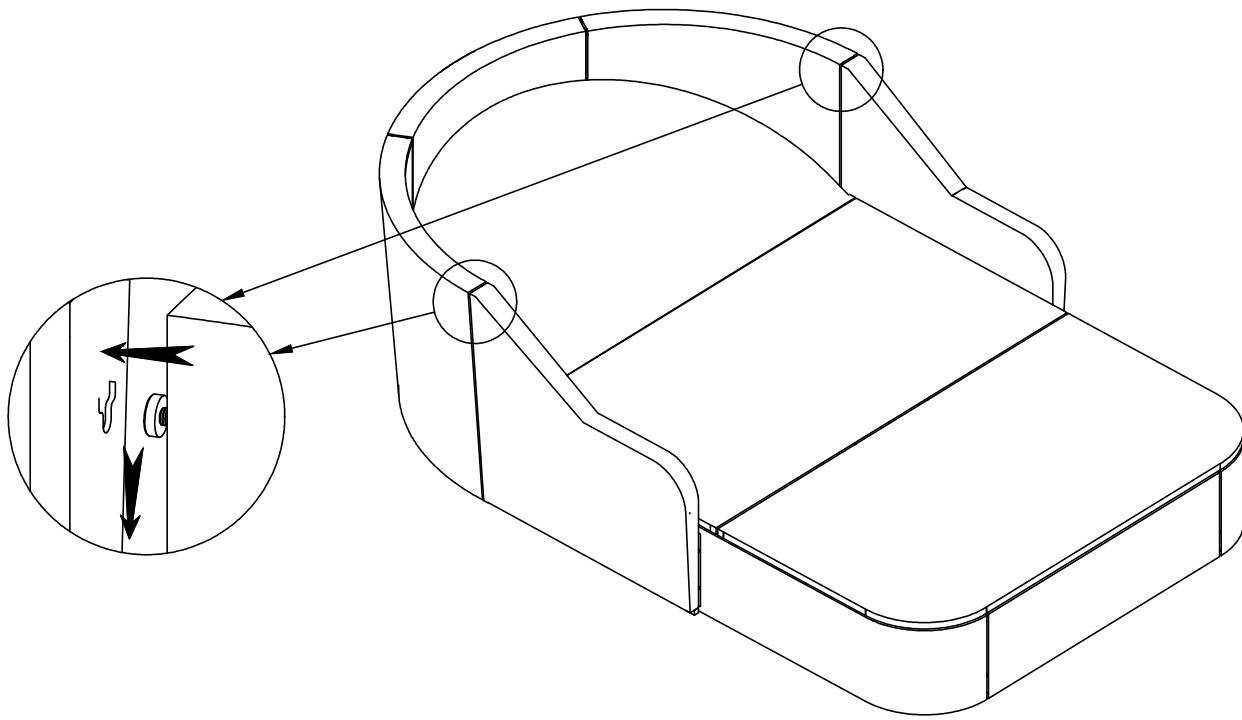

Connect The Part from Step 14 & The Part from Step 3.

STEP 16

- ④ x 2
- ⑥ x 2

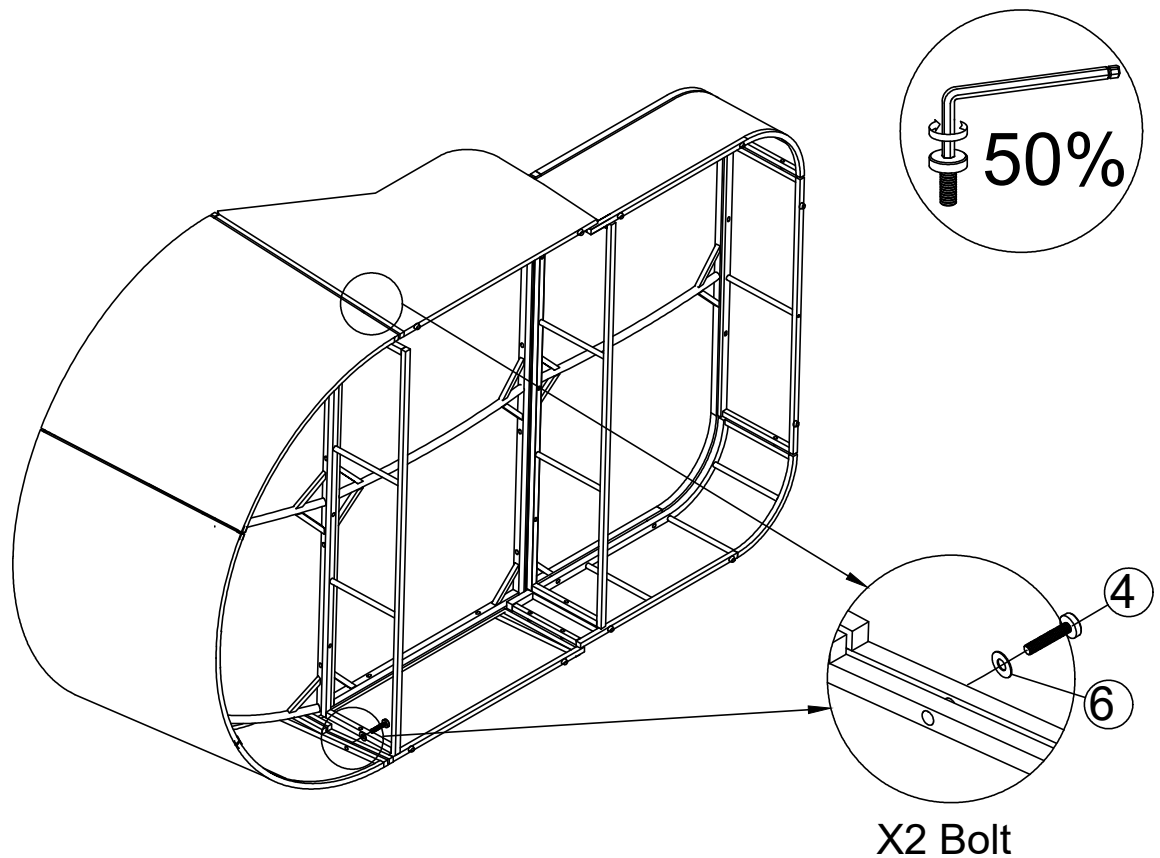

Connect The Part from Step 14 & The Part from Step 3, tighten Bolt (4), Flat Washer (6) with Allen Key (12)..

STEP 17

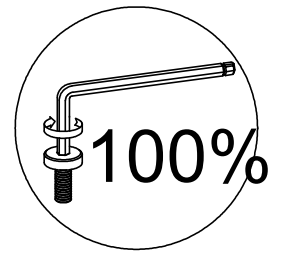
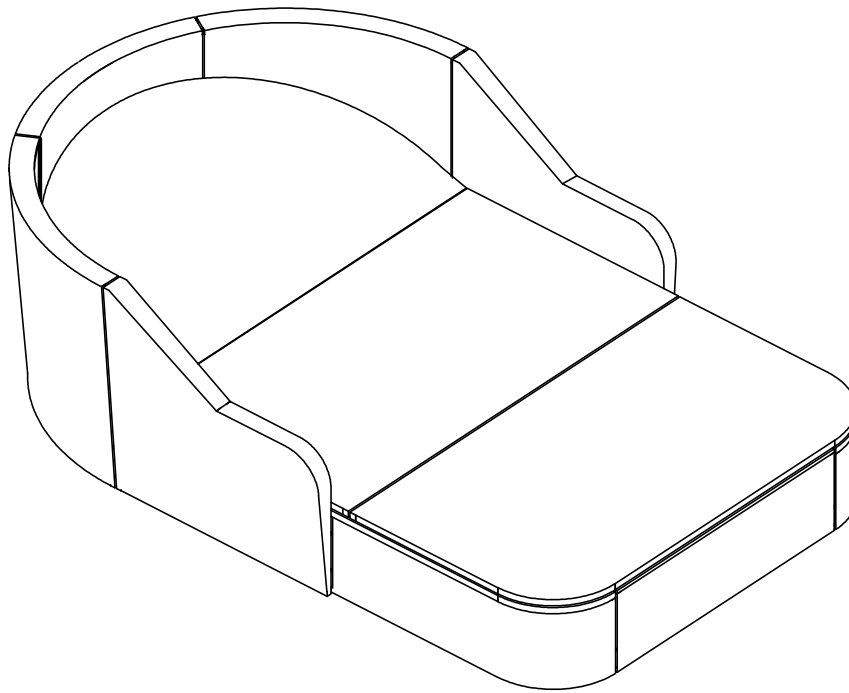

Put the Lounge upright and make sure all legs are level, then firmly tighten Bolts with Allen Key (12), Key (11)

STEP 18

- (M+) x 1
- (M-) x 1
- (N+) x 1
- (N-) x 1
- (O+) x 1
- (O-) x 1
- (P+) x 1
- (P-) x 1
- (14) x 4

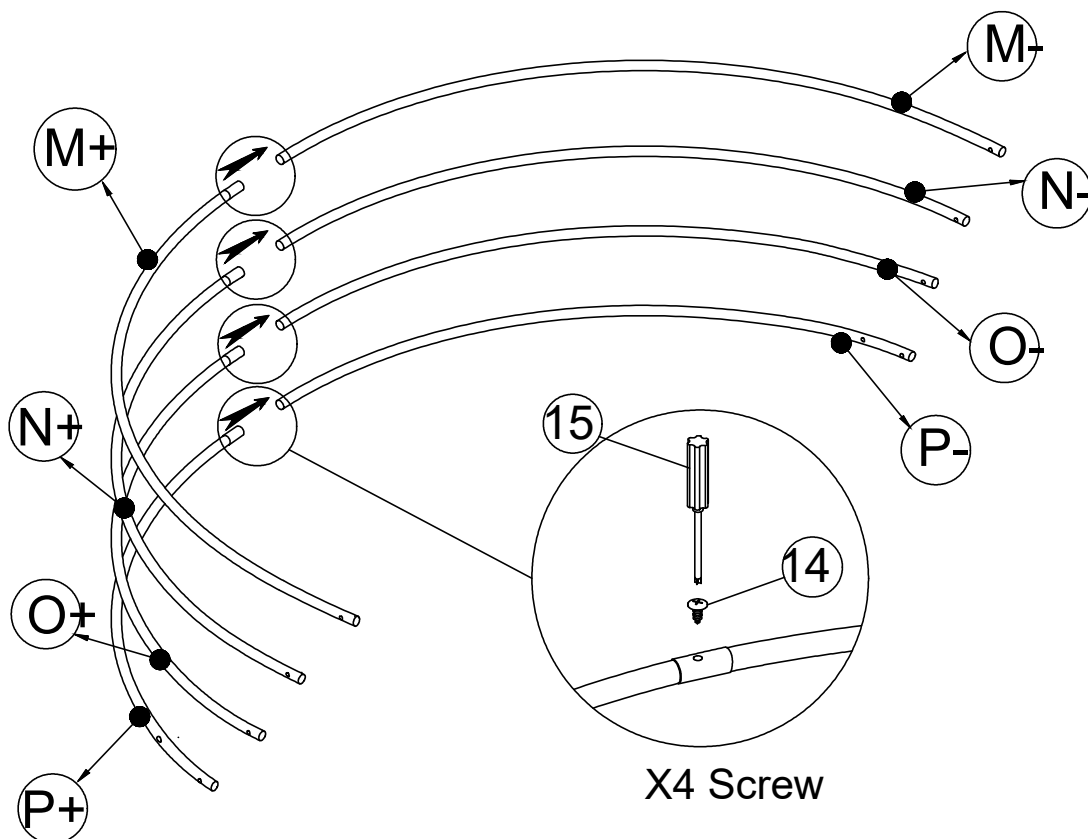

Connect The Support M+ & Support M- , Support N+ & Support N- , Support O+ & Support O- , Support P+ & Support P-. tighten Screw (14) with Screw Driver (15).

STEP 19

(M) x 1

(Q) x 1

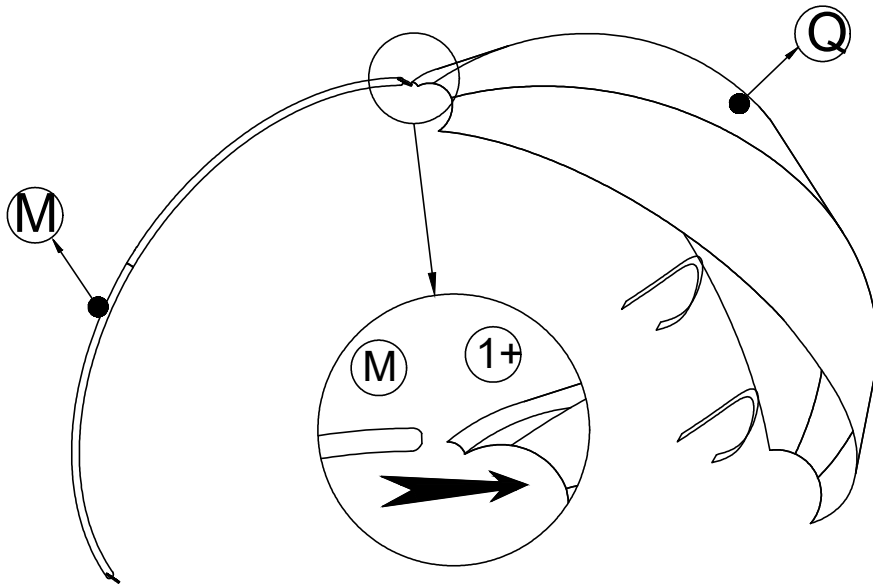

Connect The Support (M) & Covered (Q).

STEP 20

(N) x 1

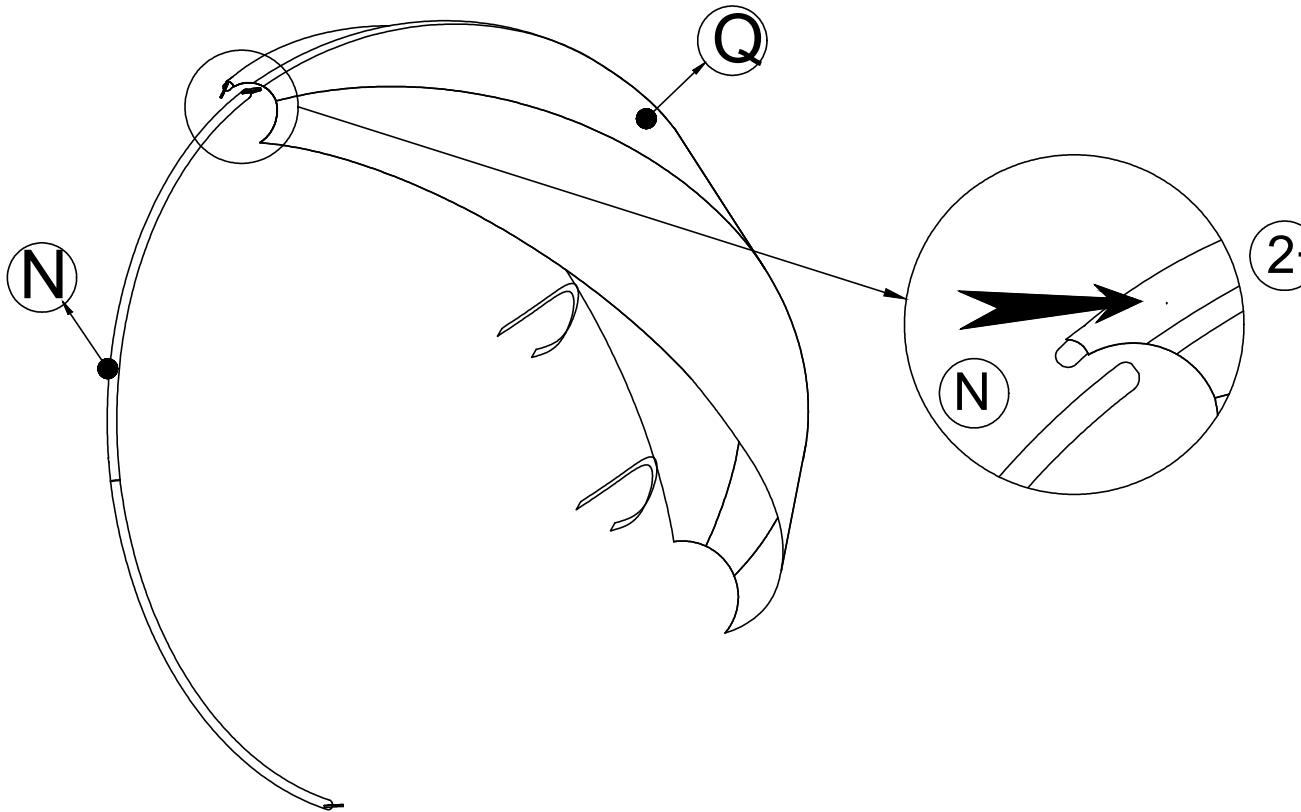

Connect The Part from Step 19 & Support (N)

STEP 21

O x 1

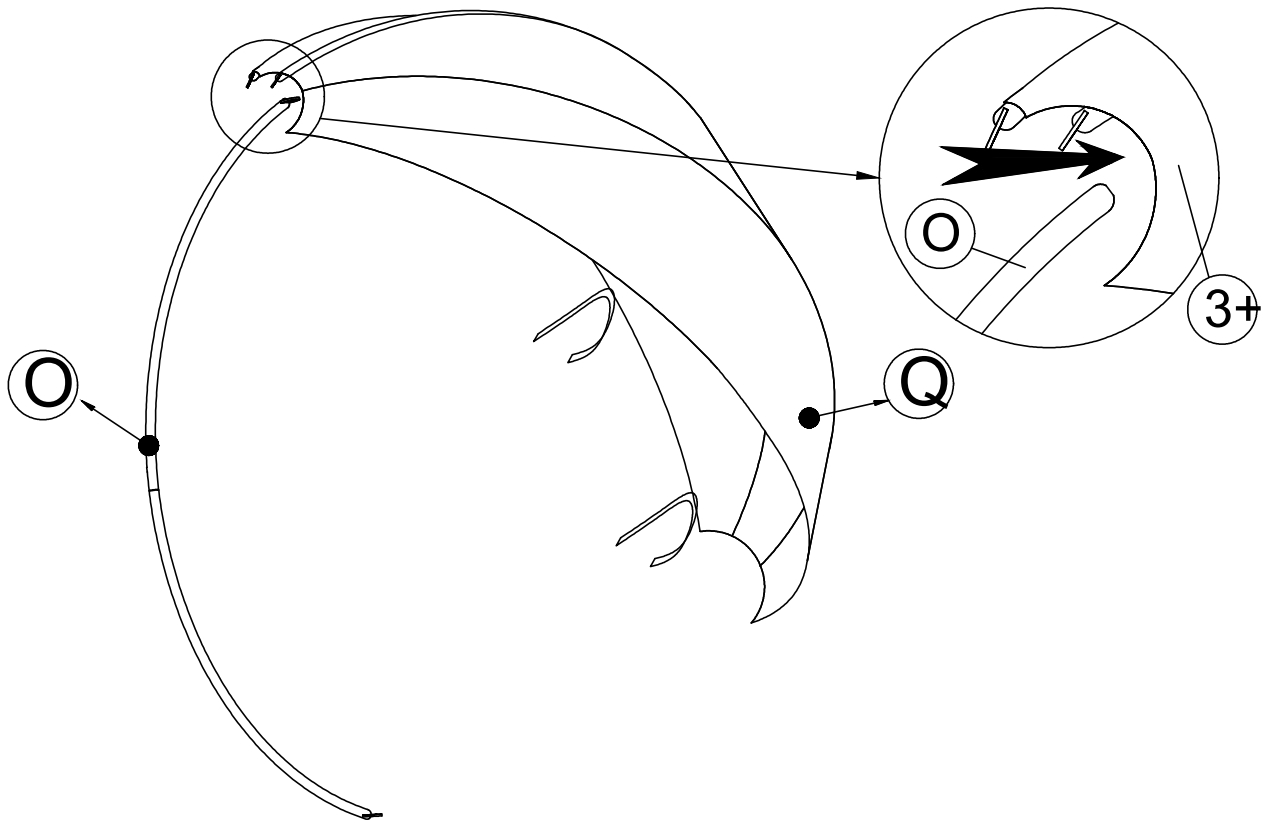

Connect The Part from Step 20 & Support (O)

STEP 22

P x 1

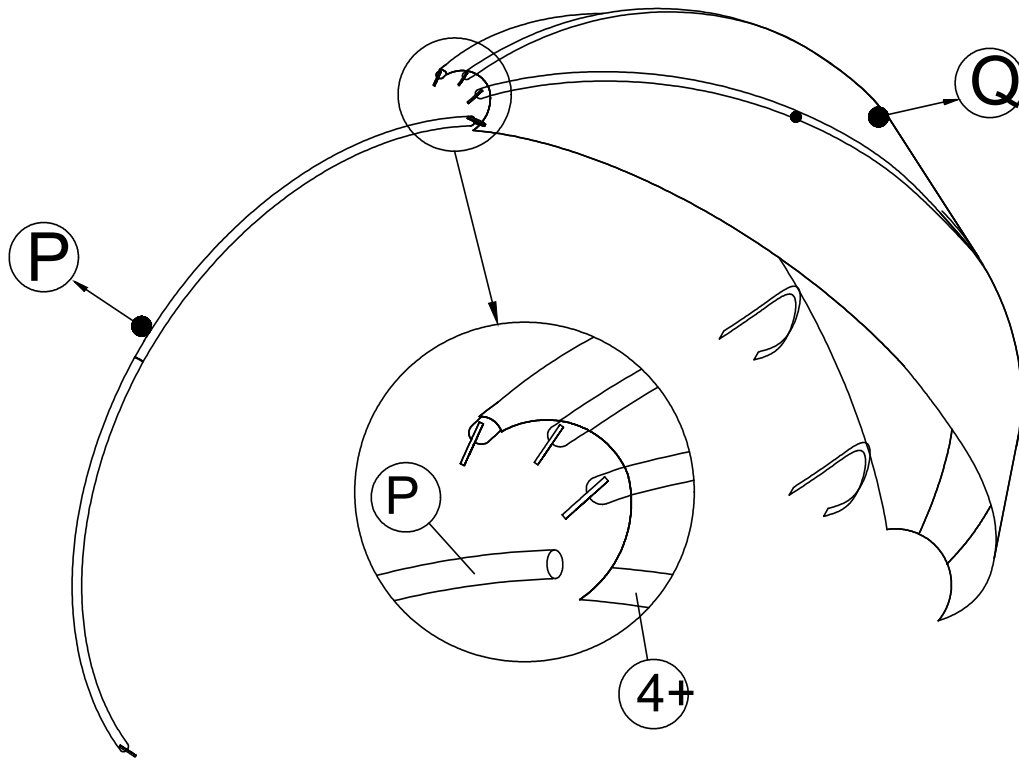

Connect The Part from Step 21 & Support (P)

STEP 23

X x 2

1 x 12

6 x 12

16 x 2

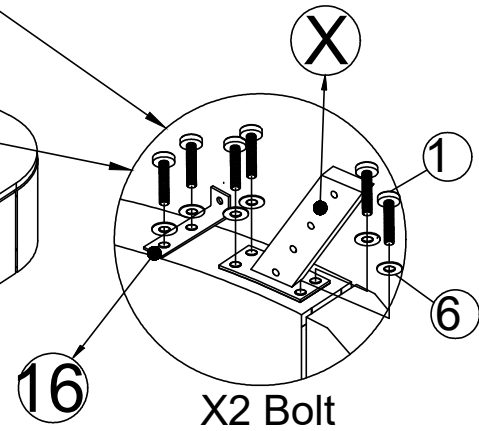
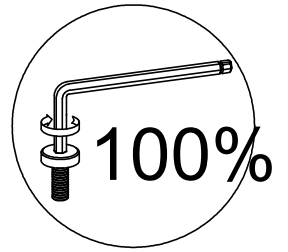
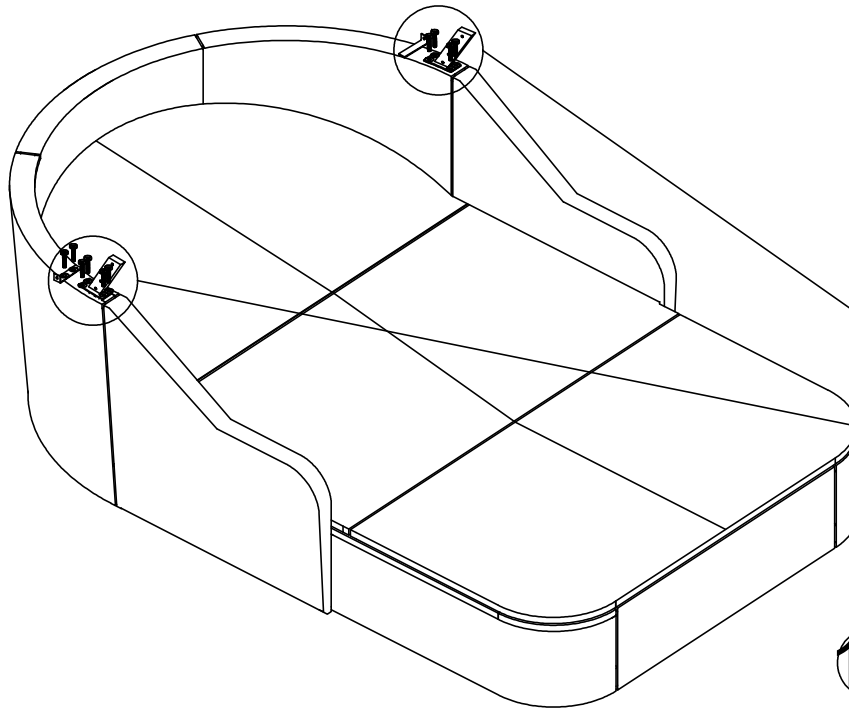

Connect The Part from Step 17 & Connection A (X) Connection (16), tighten Bolt (1), Flat Washer (6), Allen Key (12).

STEP 24

6 x 16

7 x 8

9 x 8

17 x 8

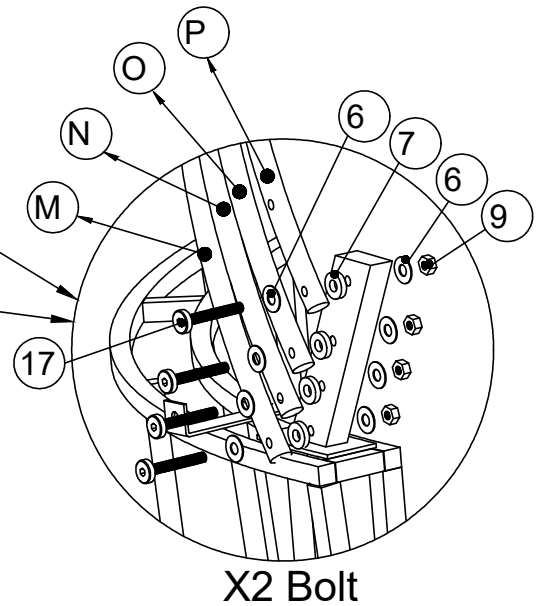
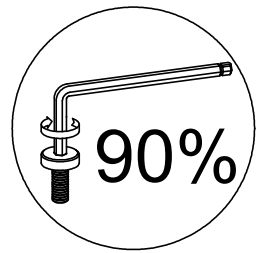
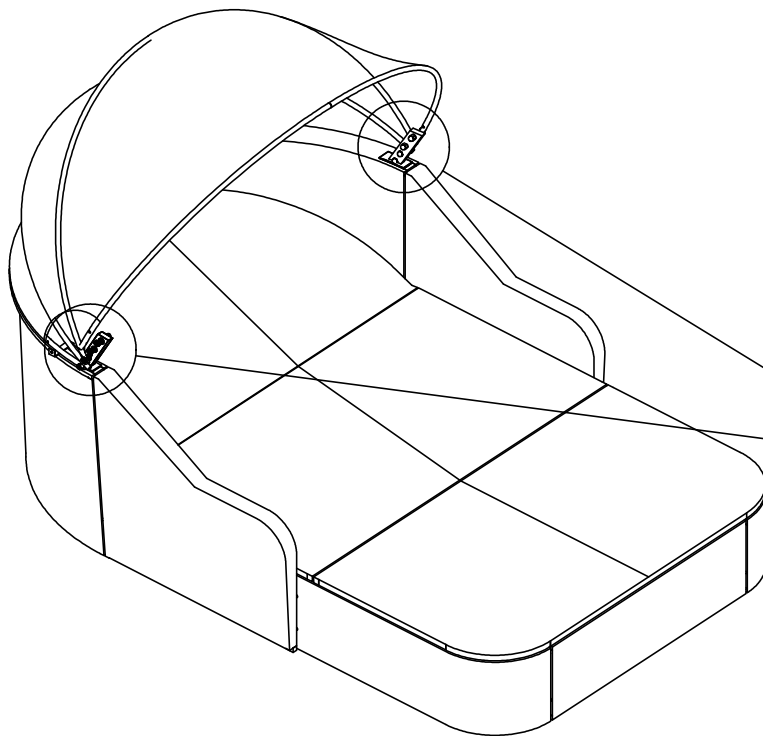

Connect The Part from Step 23 & The Part from Step 22 with tighten Bolt (17), Flat Washer (6), Washer (7), Nut (9) Allen Key (12), Key (11).

STEP 25

- ② x 2
- ③ x 2
- ⑥ x 6
- ⑦ x 2
- ⑧ x 2
- ⑨ x 2
- ⑬ x 2

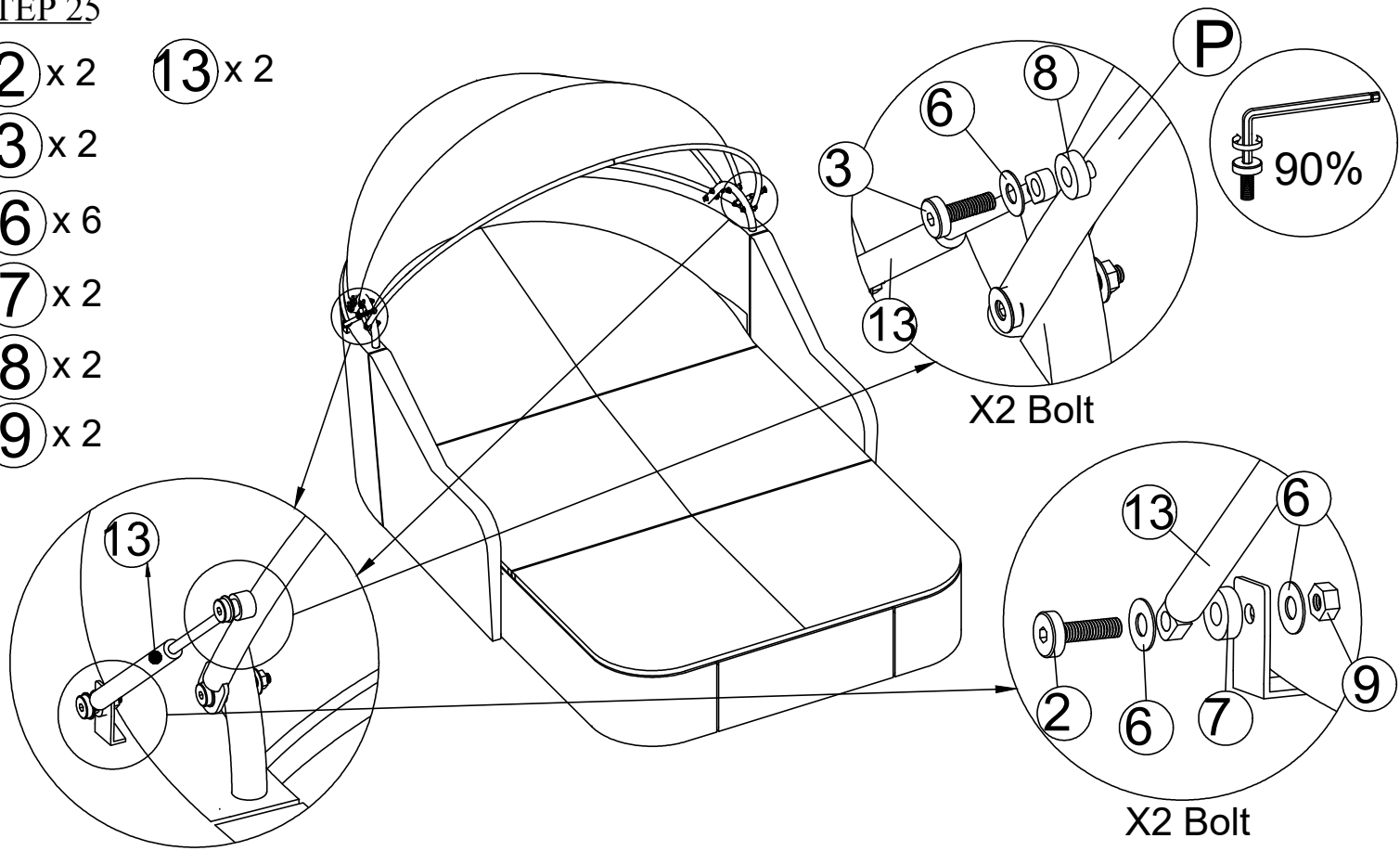

Connect The Part from Step 24 & Gaslift (13), tighten Bolt (2), Bolt (3), Flat Washer (6), Washer (7), Washer (8), Nut (9) with Allen Key (12), Key (11).

STEP 26

- ⑩ x 10
- ⑱ x 12

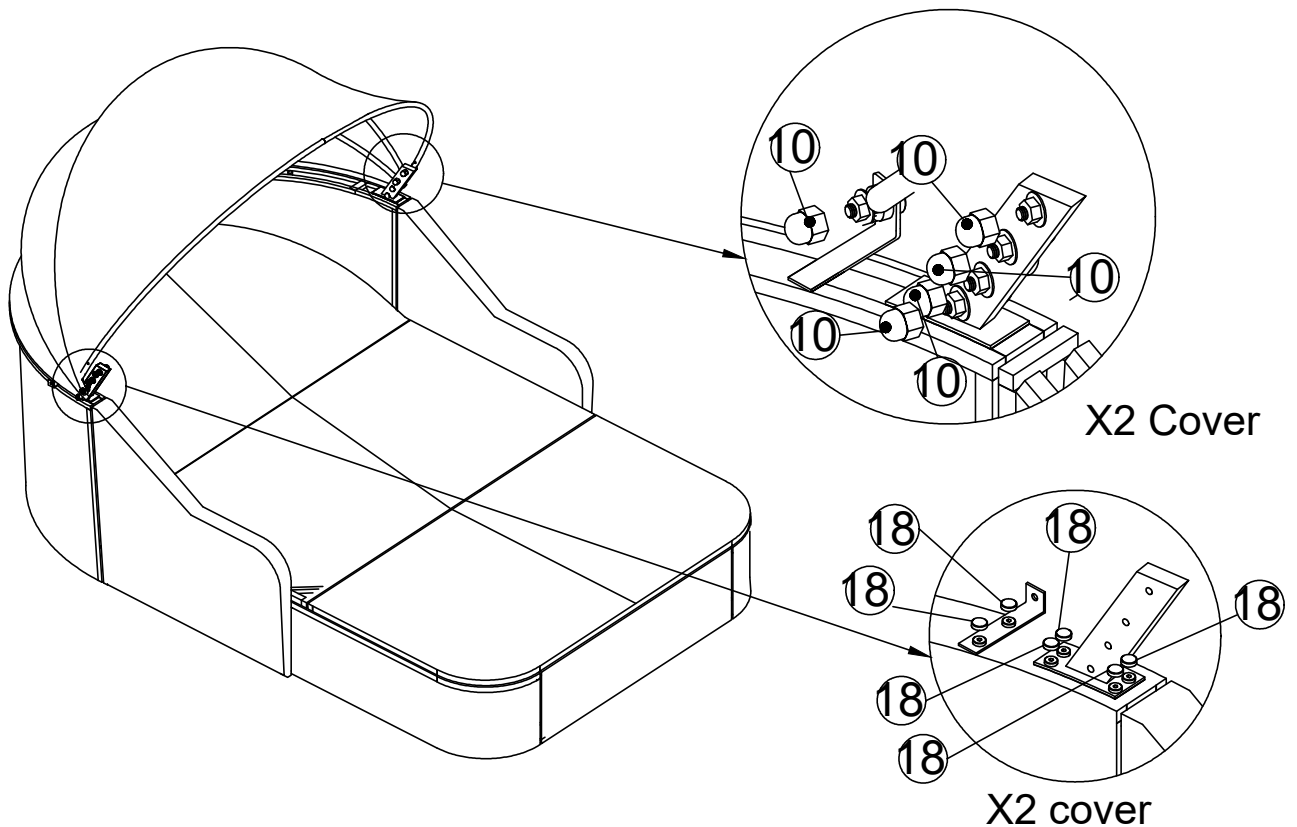

Connect The Part from STEP 25 & Cover Nut (10), Cover (18).

STEP 27

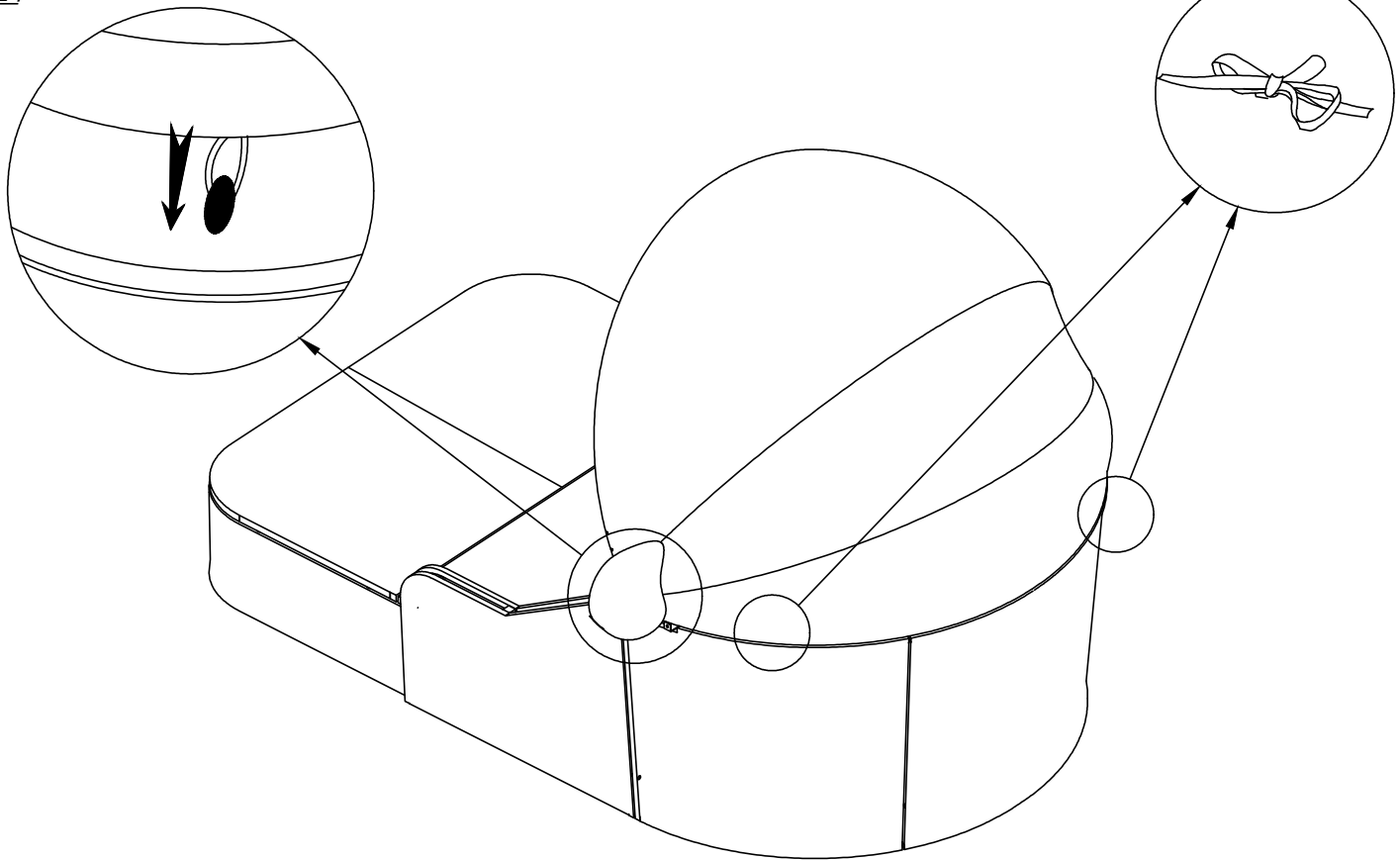

Stick string to Covered to Back Lounge.

STEP 28

⓪ x 1

Ⓥ x 1

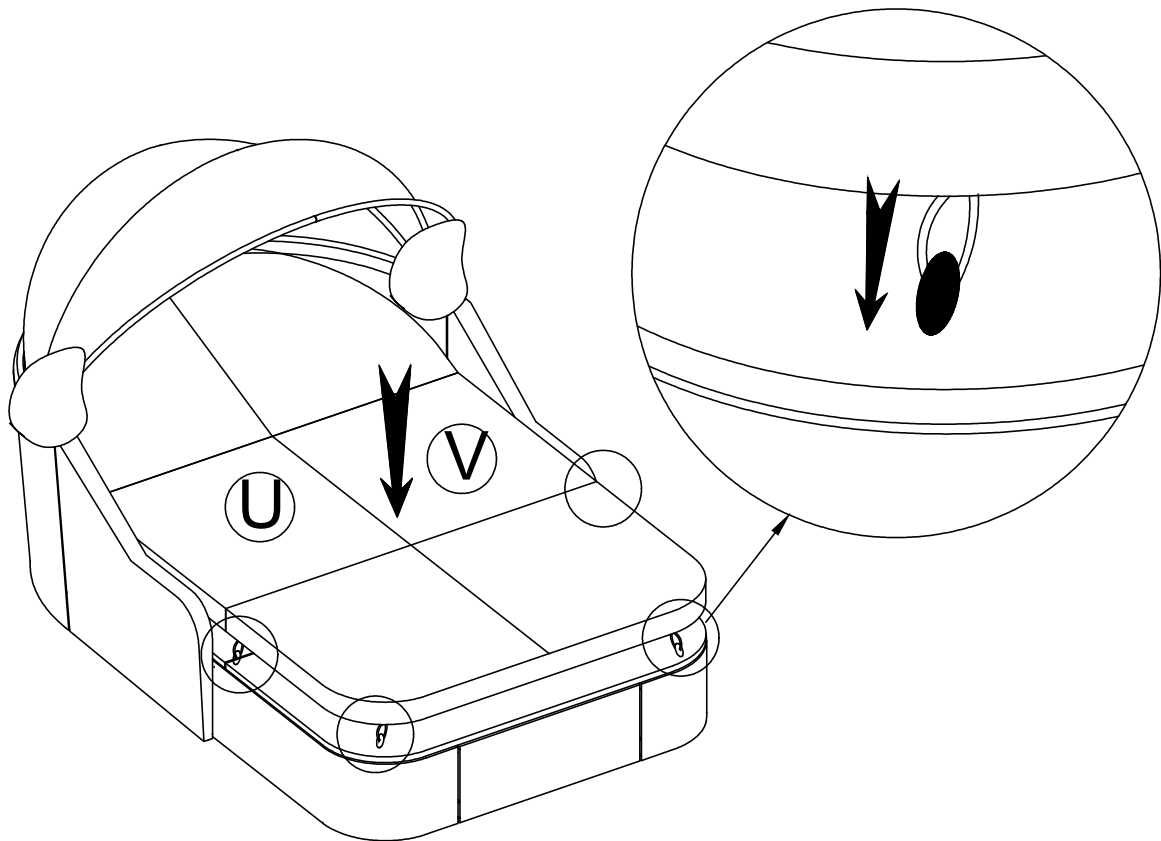

Put on Seat Cushion Right (U), Seat Cushion Left (V), to Lounge.
Stick string to Lounge .

STEP 29

(S) x 2

(T) x 2

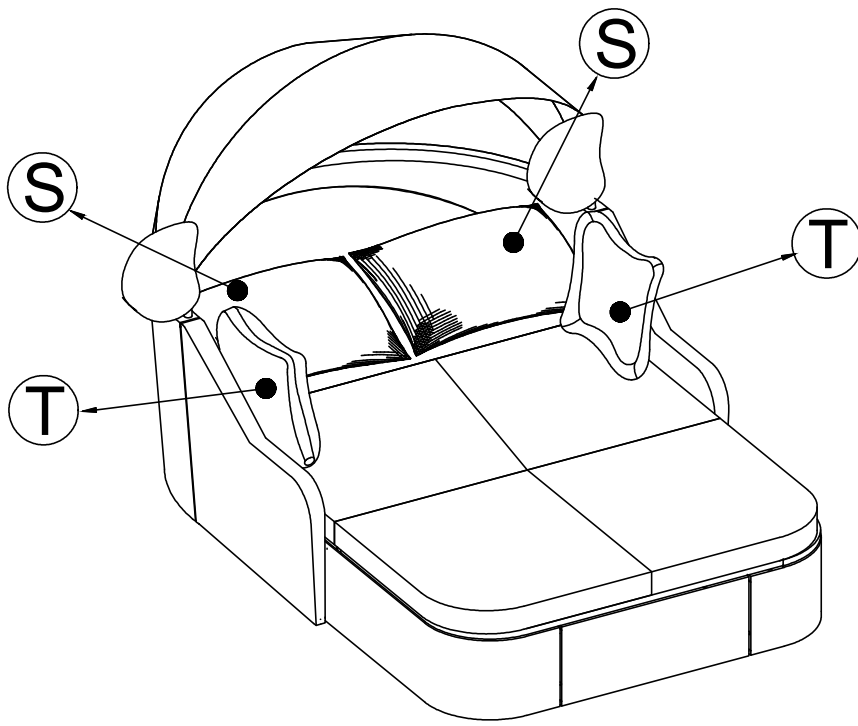

Put on Back Cushion (S) & Pillow Cushion (T) to Lounge.

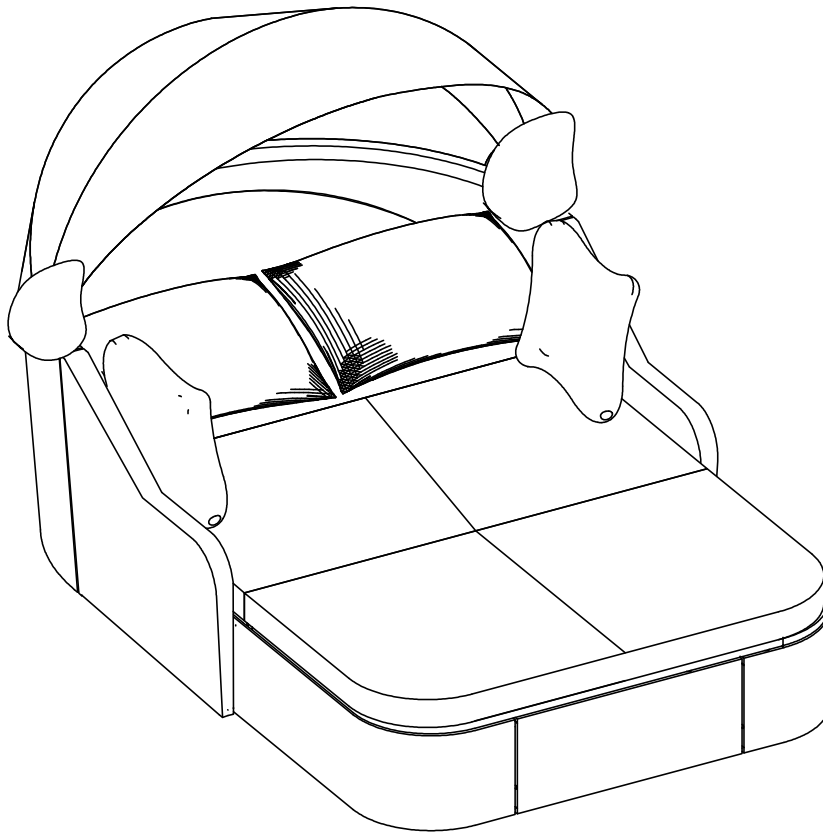

Finish Lounge

INSTALLATIONSANWEISUNG

PATIO DOUBLE LOUNGE

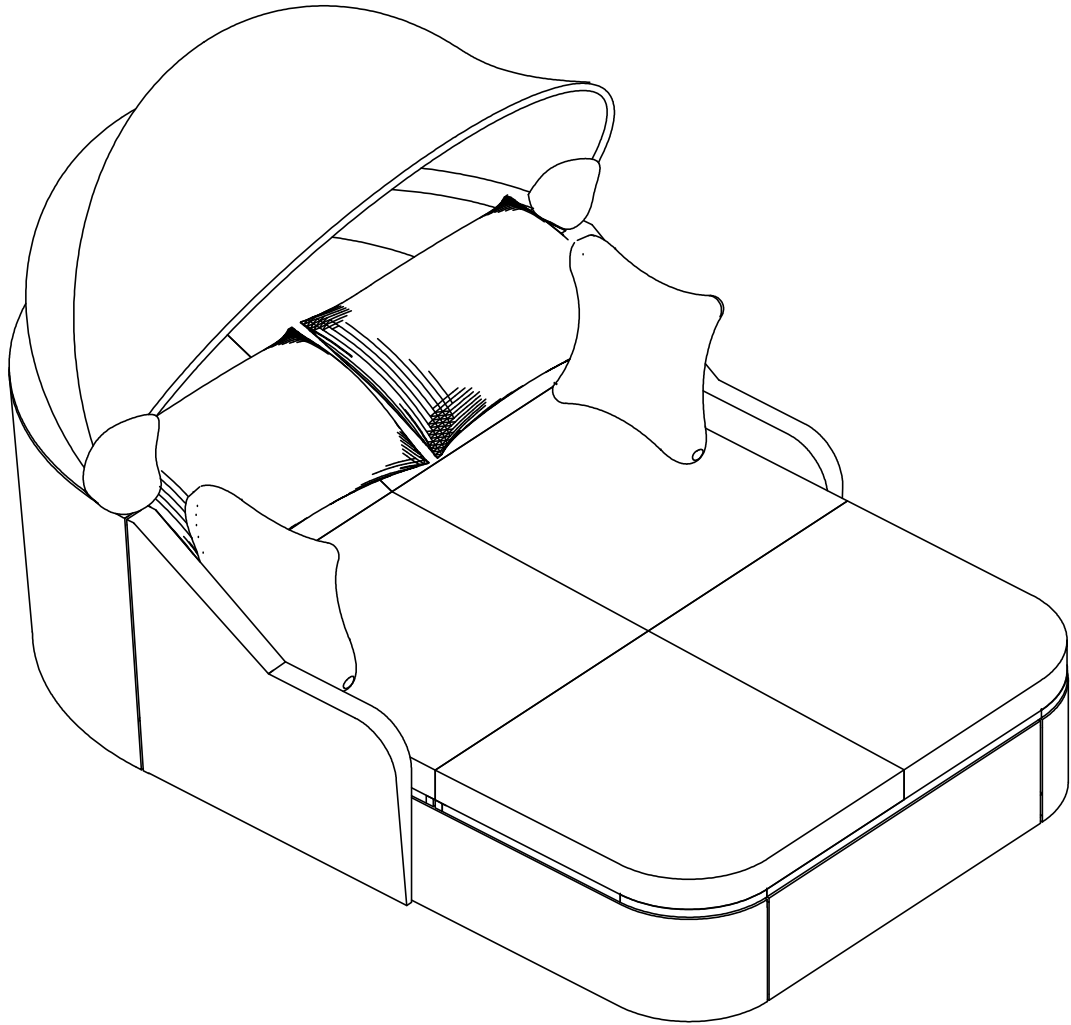

Vor dem Einbau die Schrauben in die Löcher stecken und festziehen, aber nicht bis 100%, 70% bis 80% anziehen reicht aus. Schließlich, nachdem alle Schrauben installiert sind, ziehen Sie alle Schrauben auf 100%. Wenn Sie auf diese Probleme stoßen, z.B. wenn die Löcher nicht ausgerichtet werden können oder einige Teile nicht installiert werden können, überprüfen Sie bitte, ob die Schrauben korrekt verwendet werden und passen Sie die Dichtigkeit der Schrauben an.



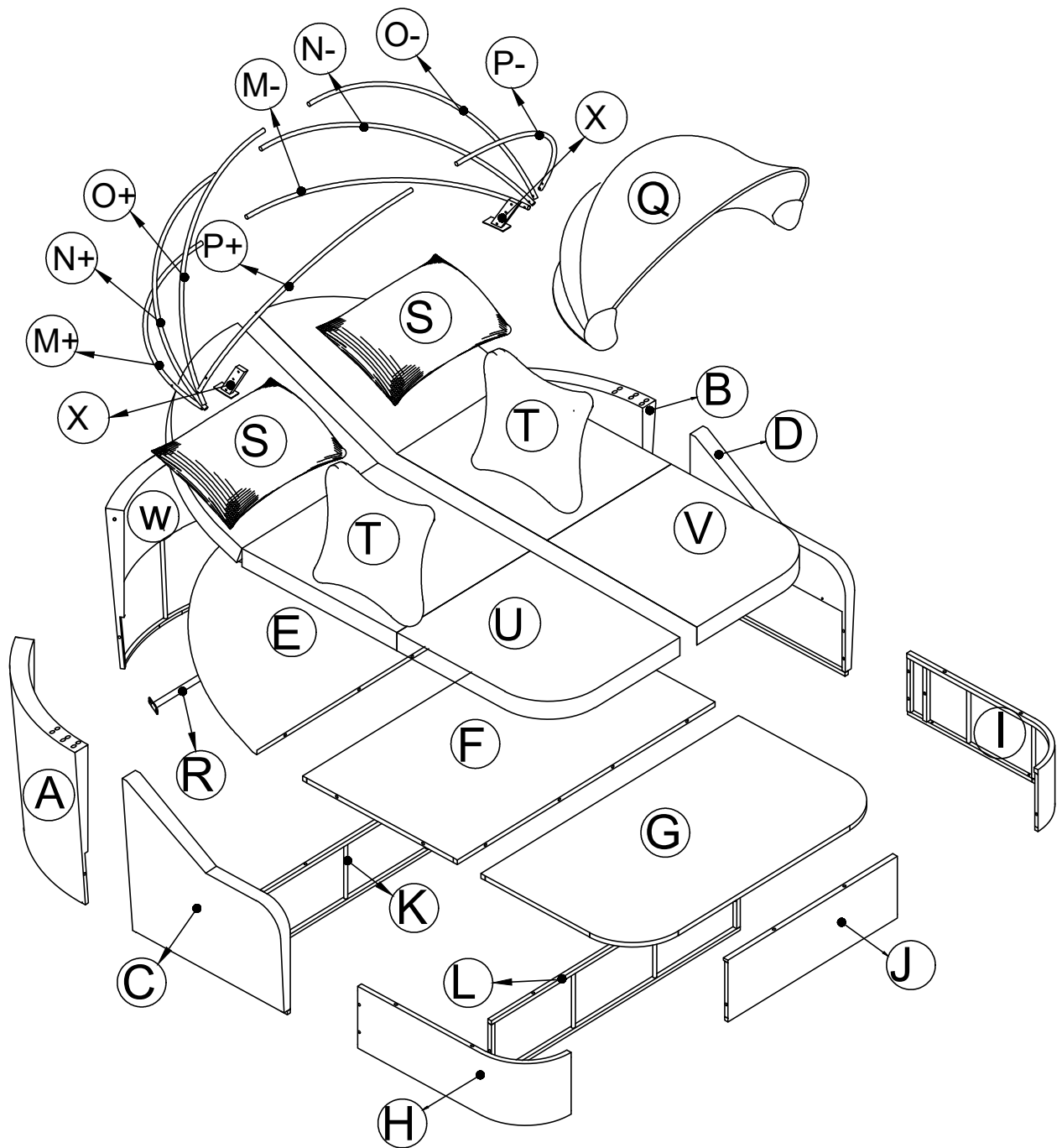





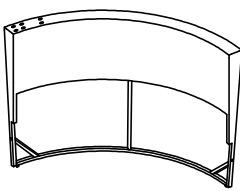
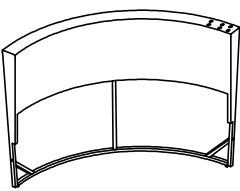
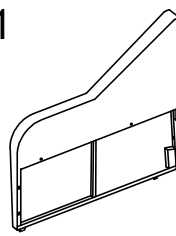
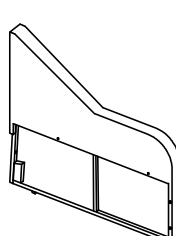
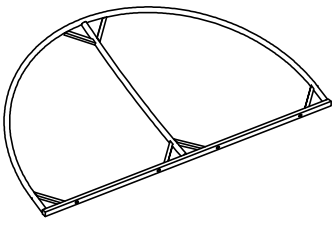
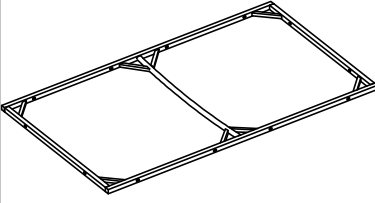
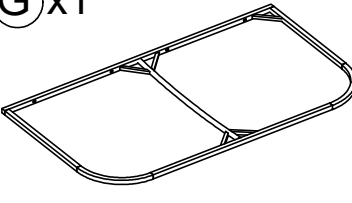
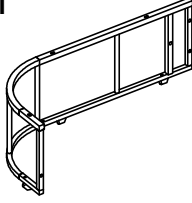
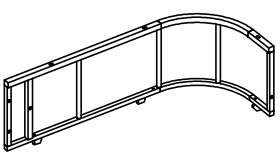
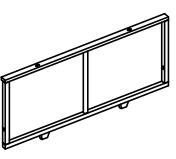
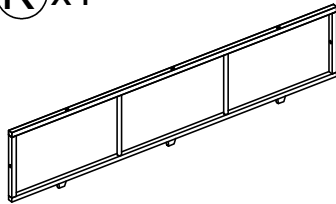
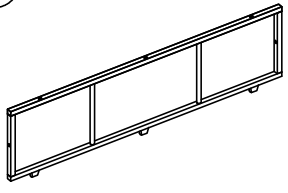

X1







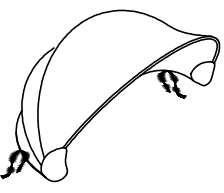
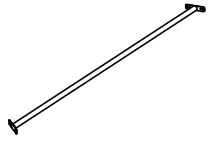
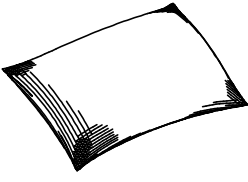

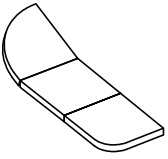
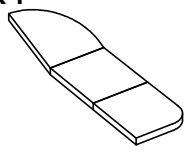
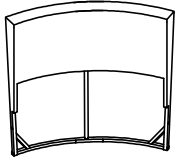
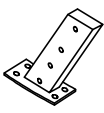



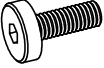
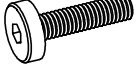

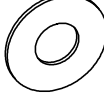

Notiz:

1. Vor dem Befestigen aller Schrauben zu 50% anziehen, Inbusschlüssel ist anstelle einer elektrischen Bohrmaschine empfohlen.
2. Legen Sie den Artikel auf einen ebenen Boden, um ihn anzupassen und zumachen sicher bleibt es stabil.
3. Ziehen Sie alle Schrauben mit Werkzeug nach und nach fest.
4. Wenn die Schrauben während der Montage, bitte alle anderen Schrauben lösen um 50% und setzen Sie den Montageprozess fort.
5. Wenn der Artikel nicht stabil ist, lösen Sie bitte alle Schrauben. auf ebenem Untergrund ausrichten und alle Schrauben festziehen wieder.
6. Hinweis: Wenn eine oder mehrere Schrauben während des Montage, es besteht die Möglichkeit, dass die anderen nicht ausgerichtet sind mit Löchern. Darüber hinaus sind alle Löcher dafür ausgelegt, zu sein relativ größer, um mehr Platz für die Einstellung der Schrauben.

Teilleiste:

<p>A x1</p>  <p>Hinten rechts</p>	<p>B x1</p>  <p>Hinten links</p>	<p>C x1</p>  <p>Arm rechts</p>	<p>D x1</p>  <p>Arm links</p>	
<p>E x1</p>  <p>Vordersitz-Lounge</p>	<p>F x1</p>  <p>Mittelsitz Lounge</p>	<p>G x1</p>  <p>Hinter Sitz Lounge</p>	<p>H x1</p>  <p>Seite Rechts Lounge</p>	
<p>I x1</p>  <p>Seite Links Lounge</p>	<p>J x1</p>  <p>Vorderseite Lounge</p>	<p>K x1</p>  <p>Vorderseite Nackt</p>	<p>L x1</p>  <p>Mitte Nackt</p>	
<p>M+ x1</p>  <p>Unterstützung M+</p>	<p>M- x1</p>  <p>Unterstützung M-</p>	<p>N+ x1</p>  <p>Unterstützung N+</p>	<p>N- x1</p>  <p>Unterstützung N-</p>	
<p>O+ x1</p>  <p>Unterstützung O+</p>	<p>O- x1</p>  <p>Unterstützung O-</p>	<p>P+ x1</p>  <p>Unterstützung P+</p>	<p>P- x1</p>  <p>Unterstützung P-</p>	
<p>Q x1</p>  <p>Abgedeckt</p>	<p>R x1</p>  <p>Unterstützung zurück</p>	<p>S x2</p>  <p>Rückenkissen</p>	<p>T x2</p>  <p>Pilow-Kissen</p>	
<p>U x1</p>  <p>Sitzkissen Rechts</p>	<p>V x1</p>  <p>Sitzkissen links</p>	<p>W x1</p>  <p>Rücken Mitte</p>	<p>X x2</p>  <p>ANSCHLUSS A</p>	

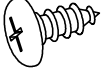
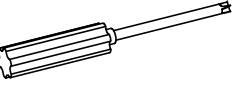
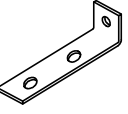
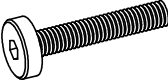
Hardware-Liste:

<p>① x 16 Stück Extra 2 Stück</p>  <p>SCHRAUBE M6 x 20MM</p>	<p>② x 2 Stück Extra 1 Stück</p>  <p>SCHRAUBE M6 x 25MM</p>	<p>③ x 12 Stück Extra 2 Stück</p>  <p>SCHRAUBE M6 x 30MM</p>	<p>④ x 20 Stück Extra 2 Stück</p>  <p>SCHRAUBE M6 x 35MM</p>
<p>⑤ x 8 Stück Extra 1 Stück</p>  <p>SCHRAUBE M6 x 60MM</p>	<p>⑥ x 84 Stück Extra 5 Stück</p>  <p>U-SCHEIBE M6</p>	<p>⑦ x 10 Stück Extra 2 Stück</p>  <p>U-Scheibe M6 x 5MM</p>	<p>⑧ x 2 Stück Extra 1 Stück</p>  <p>U-Scheibe M6 x 10MM</p>
<p>⑨ x 18 Stück Extra 2 Stück</p>  <p>MUTTER M6</p>	<p>⑩ x 10 Stück Extra 2 Stück</p>  <p>ABDECKMUTTER M6</p>	<p>⑪ x 2 Stück</p>  <p>SCHLÜSSEL</p>	<p>⑫ x 2 Stück</p>  <p>ALLEN SCHLÜSSEL</p>
<p>⑬ x 2 Stück</p>  <p>GASLIFT</p>	<p>⑭ x 4 Stück Extra 1 Stück</p>  <p>SCHRAUBE</p>	<p>⑮ x 2 Stück</p>  <p>SCREW DIVER</p>	<p>⑯ x 2 Stück</p>  <p>VERBINDUNG</p>
<p>⑰ x 8 Stück Extra 1 Stück</p>  <p>SCHRAUBE M6 x 45MM</p>	<p>⑱ x 12 Stück Extra 2 Stück</p>  <p>COVER</p>		

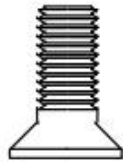

SCHRAUBE
M6x20 mm

1

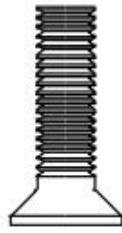

SCHRAUBE
M6x25 mm

2



SCHRAUBE
M6x30 mm

3



SCHRAUBE
M6x35 mm

4



SCHRAUBE
M6x60 mm

5



SCHRAUBE

14



SCHRAUBE
M6x45 mm

17

Bitte beachten Sie, dass die Formen der Schrauben 1 und 2 und 3 ähnlich sind.
Bitte installieren Sie entsprechend der Anleitung und unterscheiden Sie sie!

INHALT DES KARTONS

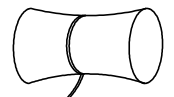
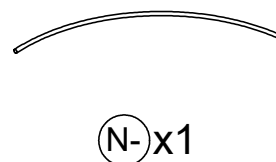
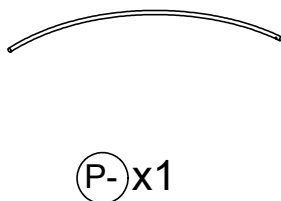
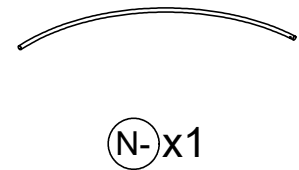
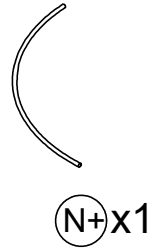
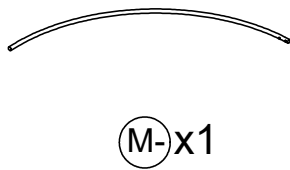
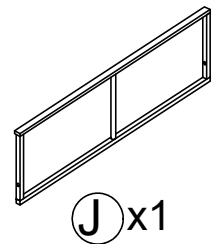
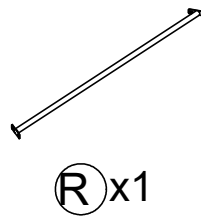
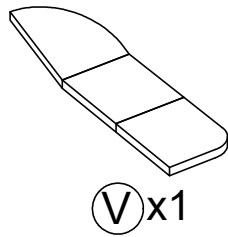
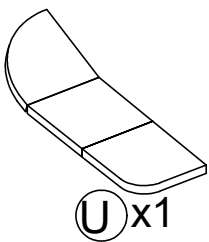
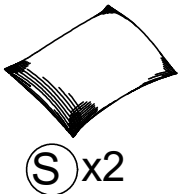
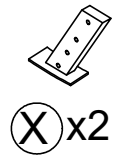
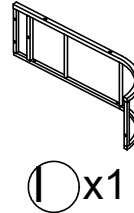
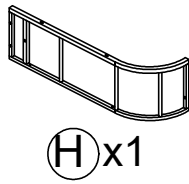
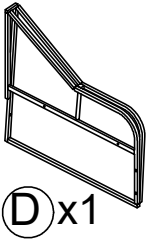
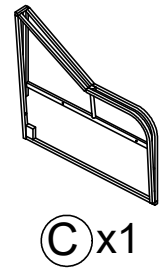
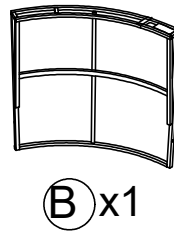
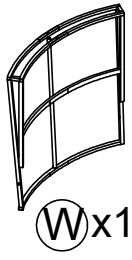
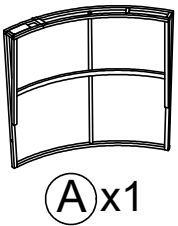
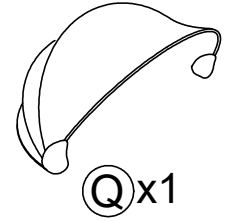
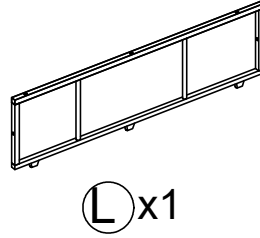
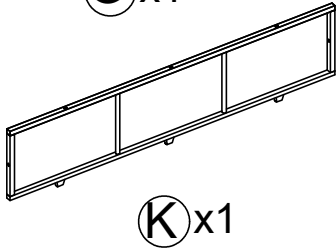
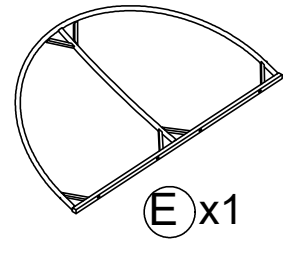
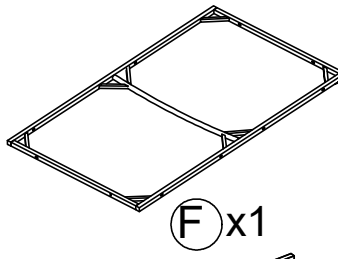
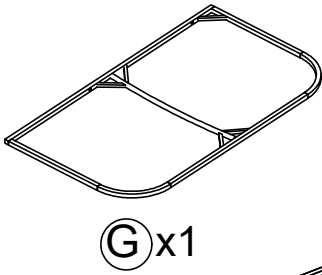

SCHRITT 1

W x 1

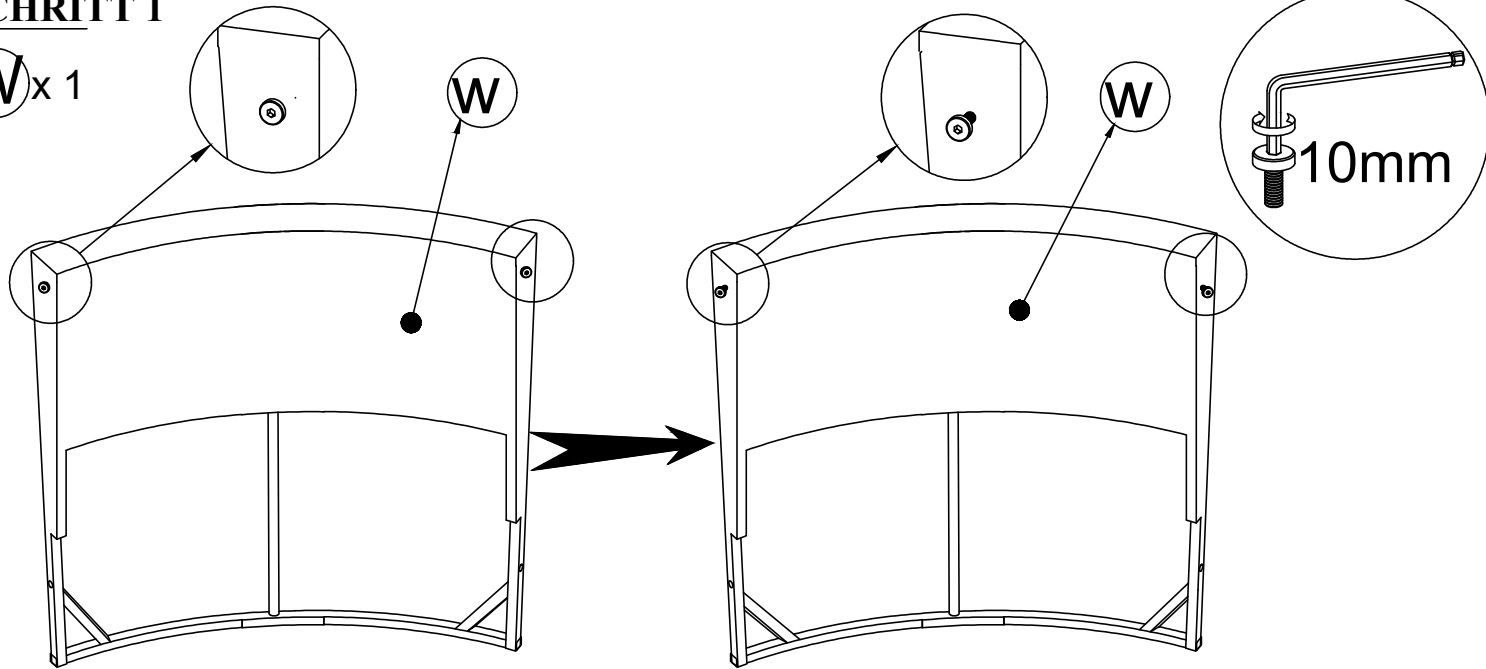

Lösen Sie mit dem Inbusschlüssel die Schraube an der Seite der hinteren Mitte (W) um 10 mm.

SCHRITT 2

A x 1

B x 1

4 x 2

6 x 2

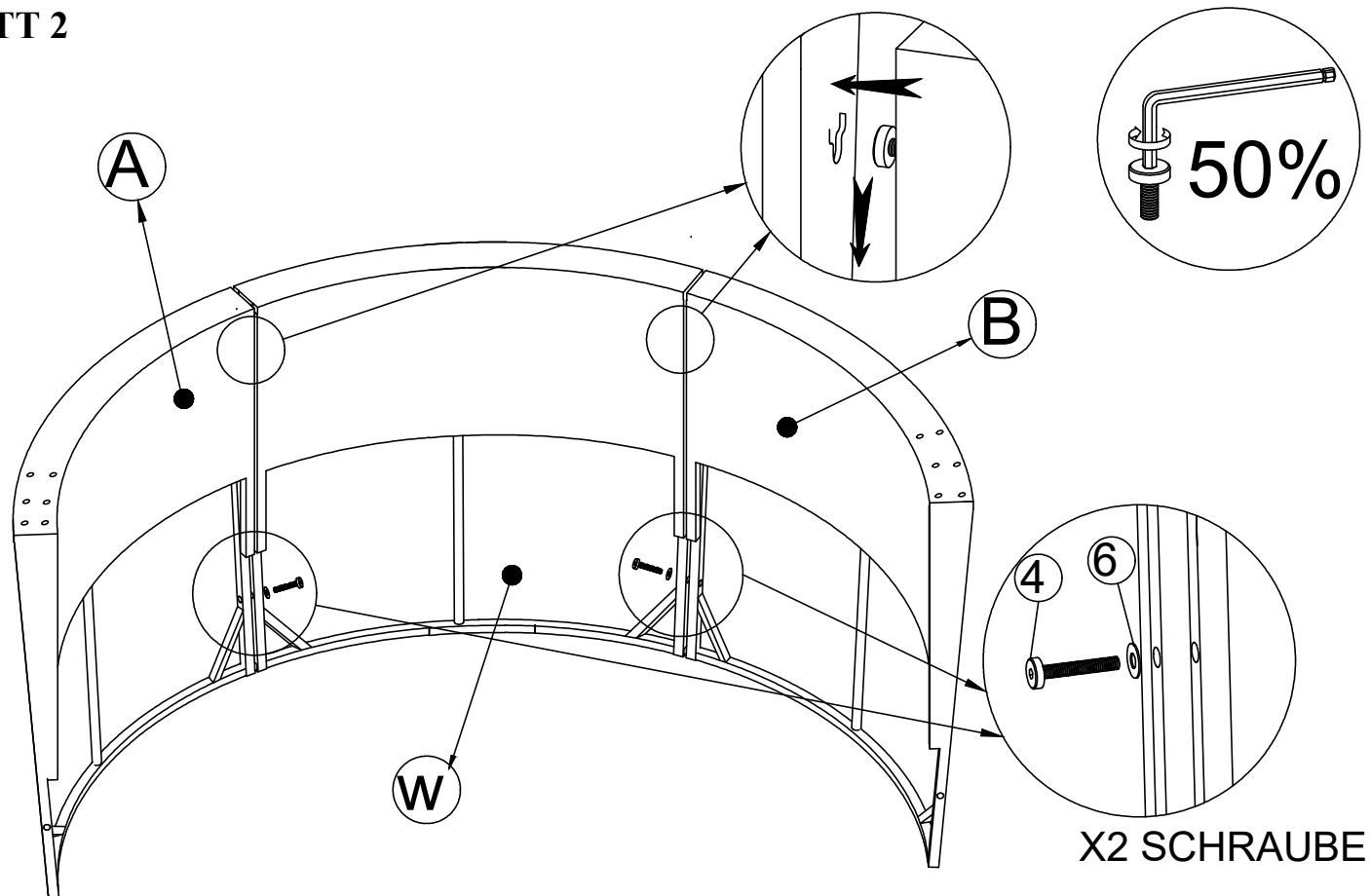

X2 SCHRAUBE

Verbinden Sie das Teil aus Schritt 1 und hinten rechts (A), hinten links (B), ziehen Sie die Schraube (4) und die Unterlegscheibe (6) mit dem Inbusschlüssel (12) fest.

SCHRITT 3

(R) x 1

(1) x 4

(6) x 4

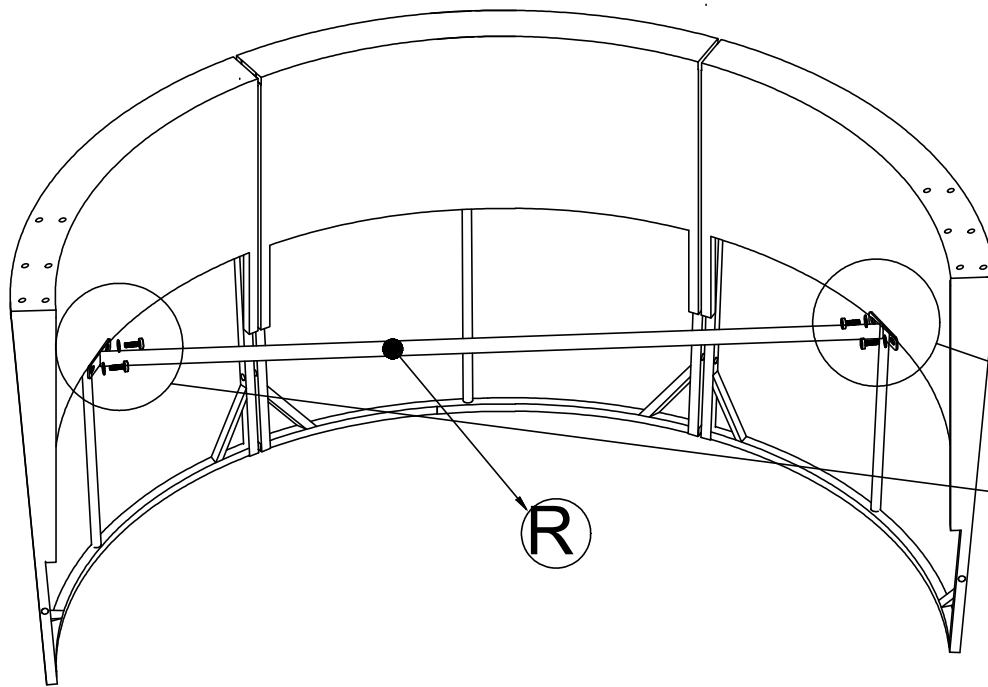

X2 SCHRAUBEN

Verbinden Sie das Teil aus Schritt 2 mit der Rückenlehne (R), ziehen Sie die Schraube (1) und die Unterlegscheibe (6) mit dem Inbusschlüssel (12) fest.

SCHRITT 4

(G) x 1

(H) x 1

(4) x 2

(6) x 2

X2
Schraube

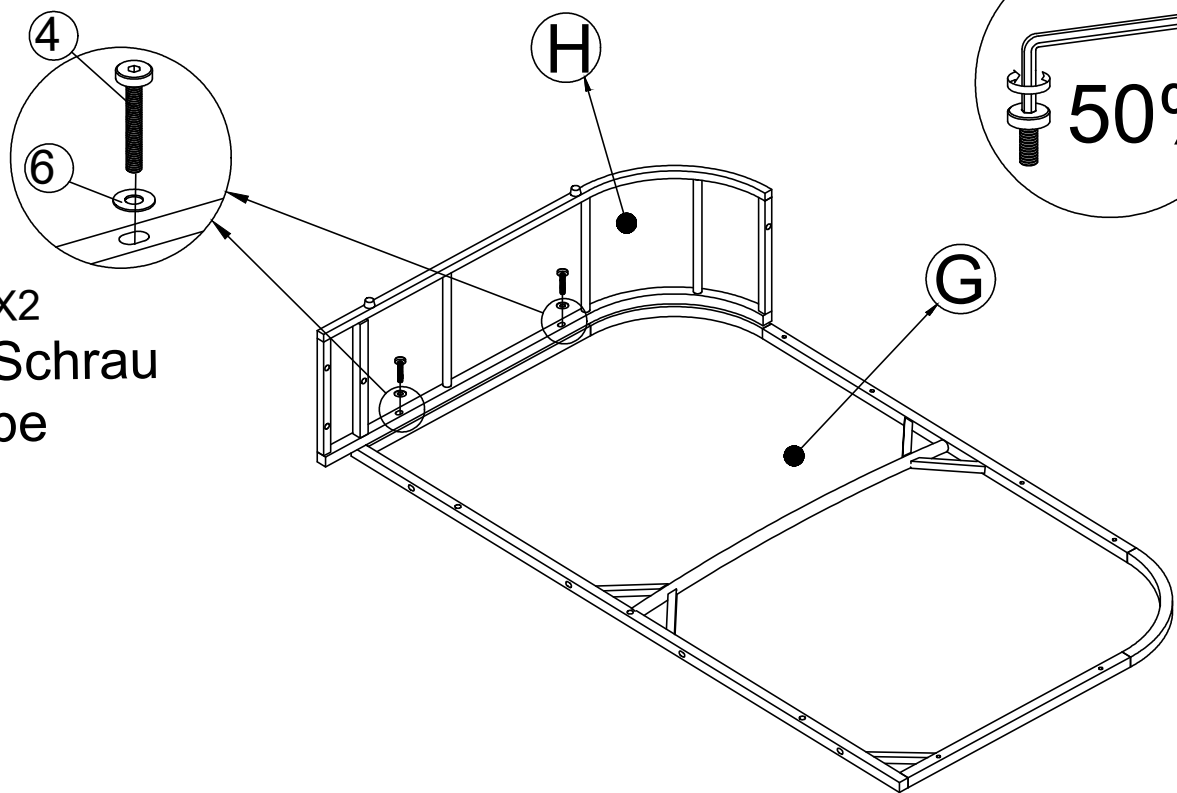

Verbinden Sie die hintere Sitzbank (G) und die rechte Seitenbank ziehen Sie die Schraube (4) und die Unterlegscheibe (6) mit dem Inbusschlüssel (12) fest.

SCHRITT 5

- ① x 1
- ④ x 2
- ⑥ x 2

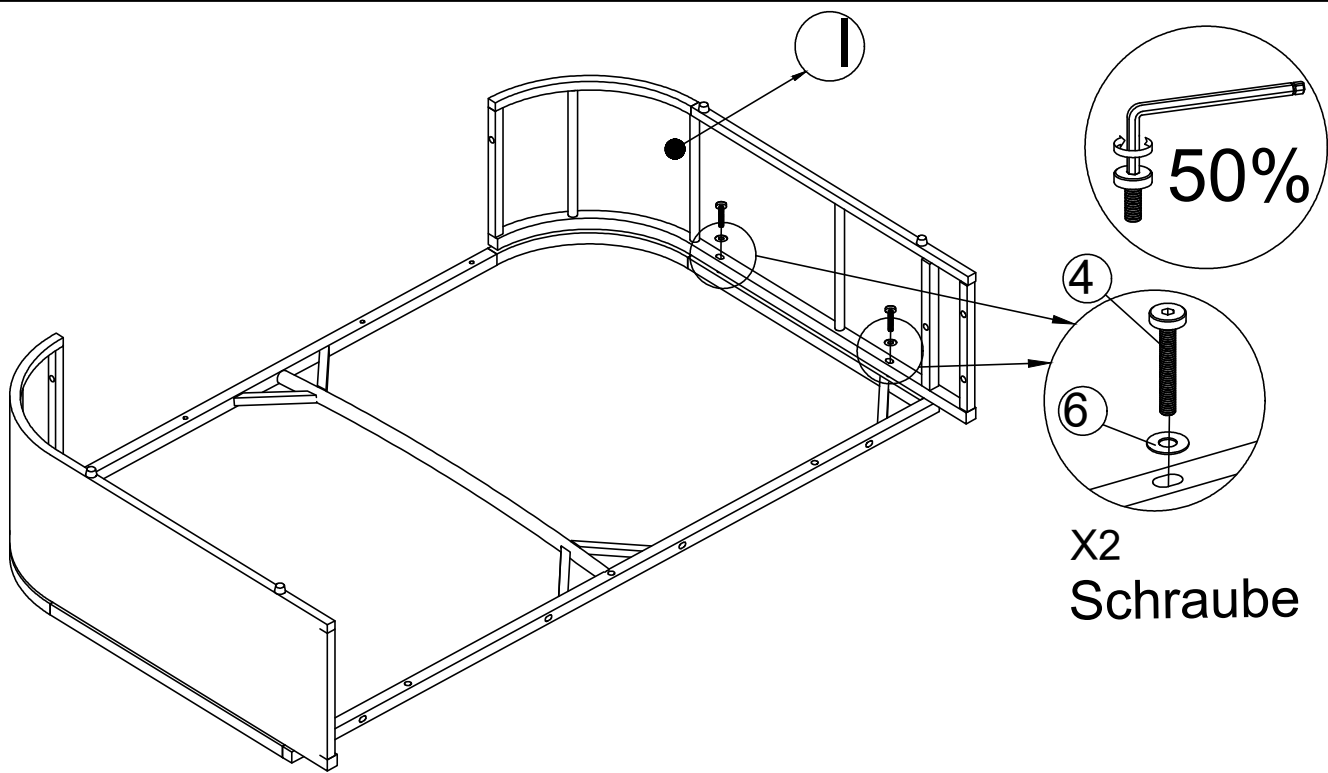

X2
Schraube

Verbinden Sie das Teil aus Schritt 4 mit der linken Seitenstütze (I), ziehen Sie die Schraube (4) und die Unterlegscheibe (6) mit dem Inbusschlüssel (12) fest.

SCHRITT 6

- ③ x 1
- ③ x 2
- ④ x 2
- ⑥ x 4

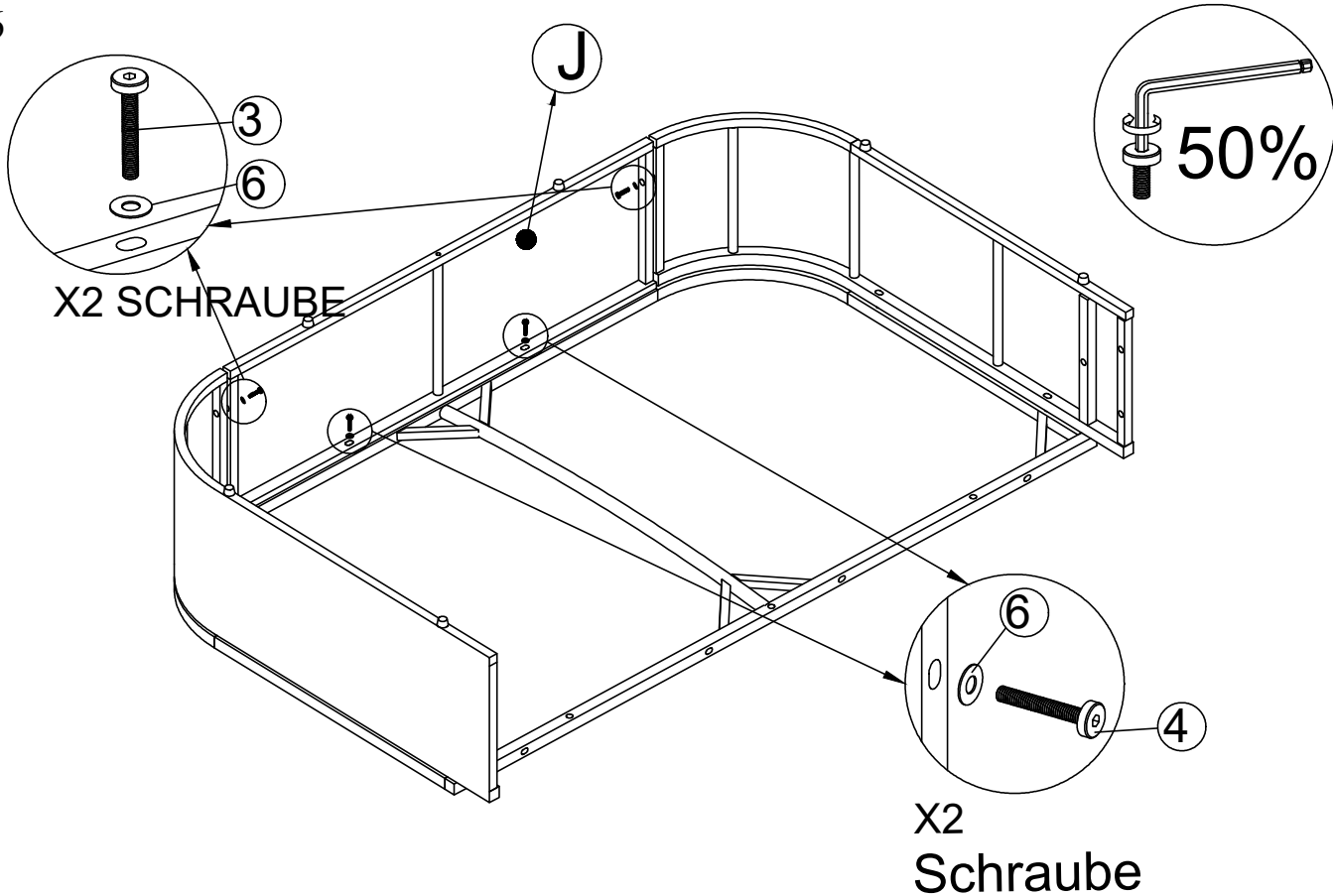

X2 SCHRAUBE

X2
Schraube

Verbinden Sie das Teil aus Schritt 5 mit der vorderen Lounge (J), ziehen Sie Schraube (3), Schraube (4) und Unterlegscheibe (6) mit dem Inbusschlüssel (12) fest.

SCHRITT 7

(L) x 1

(3) x 2

(4) x 3

(6) x 5

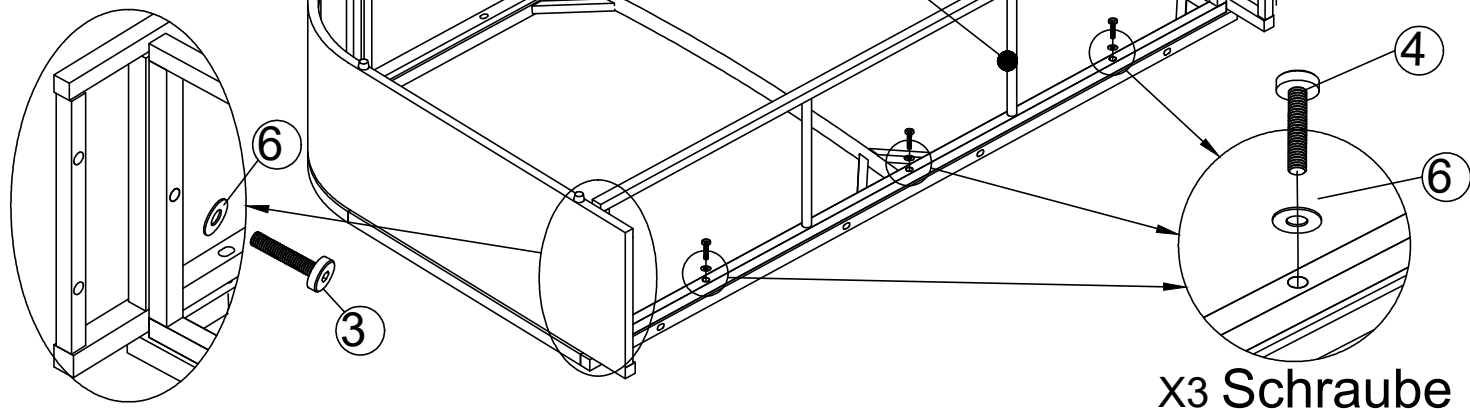

x3 Schraube

Verbinden Sie das Teil aus Schritt 6 und den mittleren Bügel (L), ziehen Sie Schraube (3), Schraube (4) und Unterlegscheibe (6) mit dem Inbusschlüssel (12) fest.

SCHRITT 8

(F) x 1

(5) x 4

(6) x 8

(9) x 4

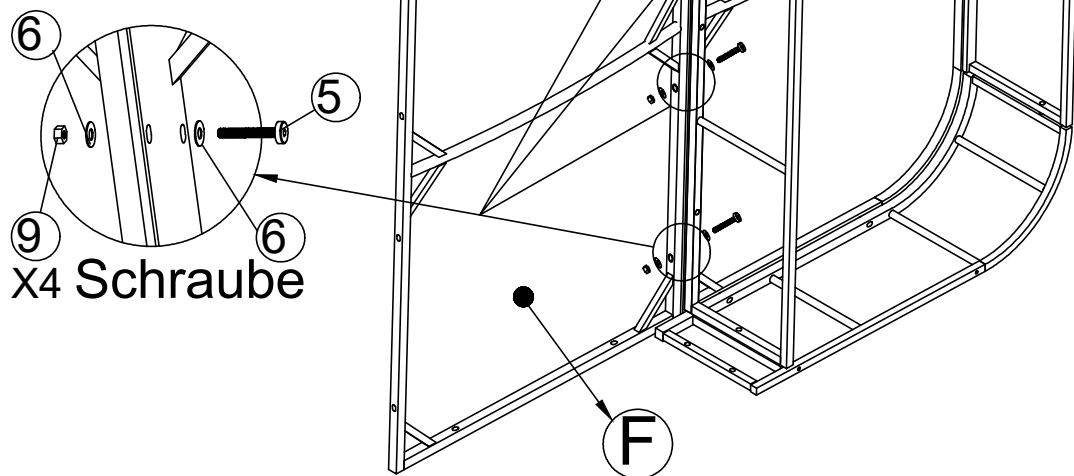

x4 Schraube

Verbinden Sie das Teil aus Schritt 7 mit der mittleren Sitzbank (F), ziehen Sie die Schraube (5), die Unterlegscheibe (6) und die Mutter (9) mit dem Inbusschlüssel (12) und dem Schlüssel (11) fest.

SCHRITT 9

Ⓒ x 1

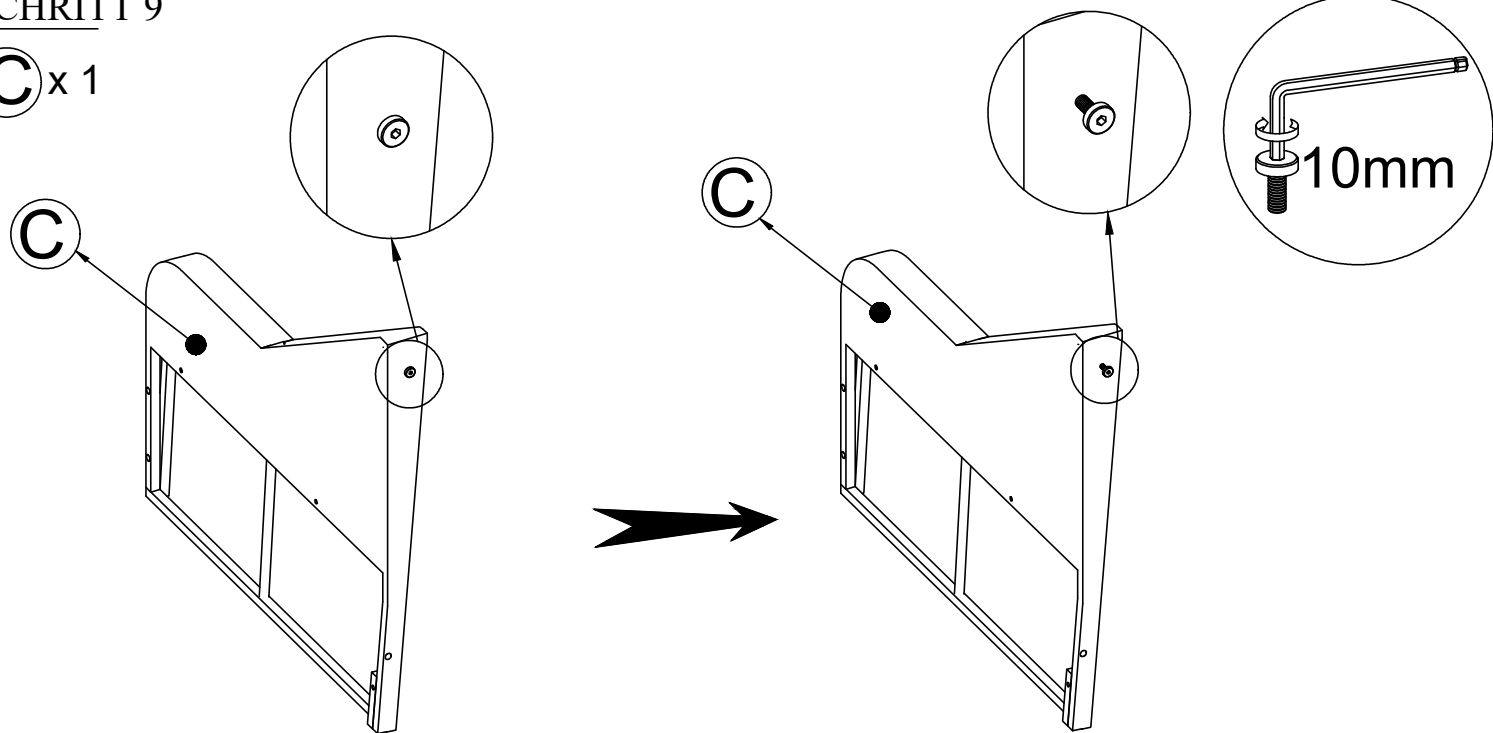

Lösen Sie mit dem Inbusschlüssel die Schraube an der Seite des rechten Arms (C) um 10 mm.

SCHRITT 10

Ⓓ x 1

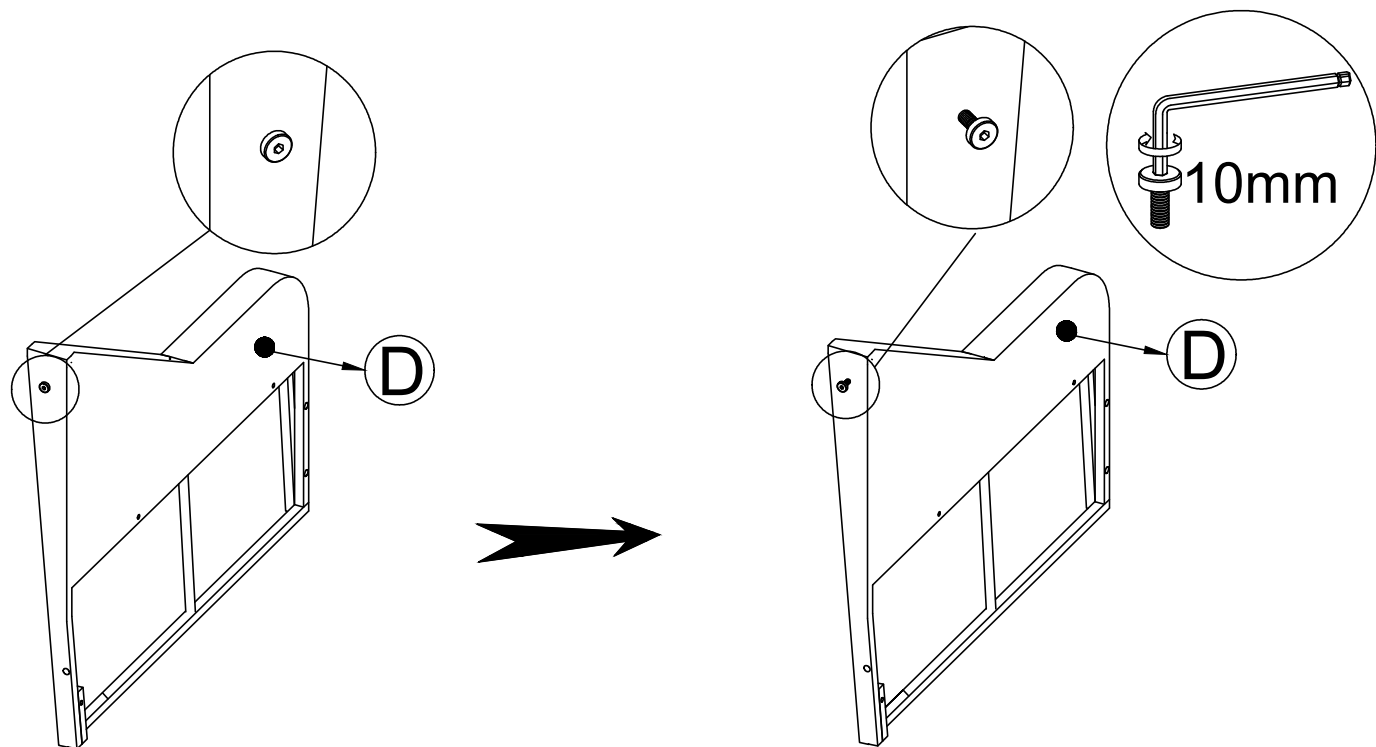

Lösen Sie mit dem Inbusschlüssel die Schraube an der Seite des linken Arms (D) um 10 mm.

SCHRITT 11

Ⓓ x 1

③ x 2

④ x 2

⑥ x 4

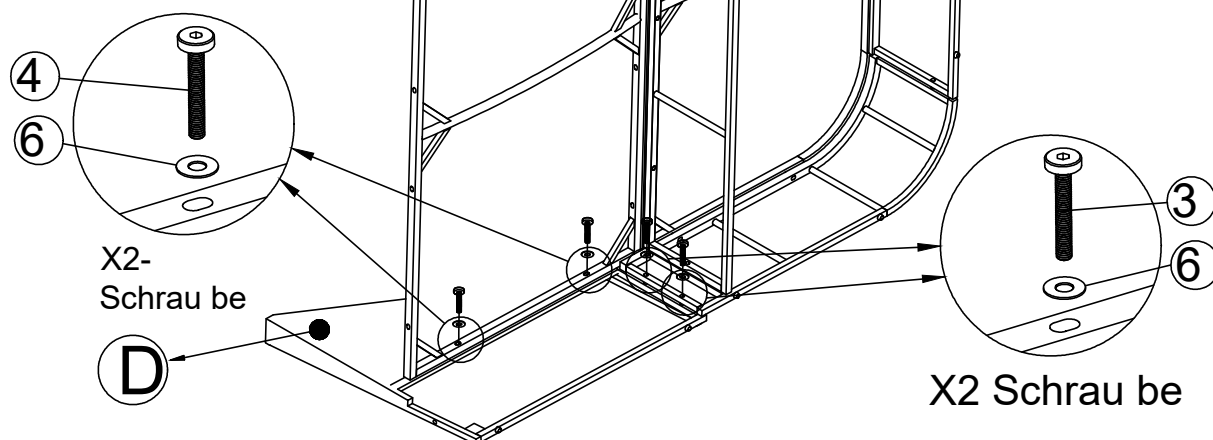

Verbinden Sie das Teil aus Schritt 8 und das Teil aus Schritt 10 und ziehen Sie die Schraube fest.(3),Schraube (4) Unterlegscheibe (6) mit Inbusschlüssel (12).

SCHRITT 12

Ⓒ x 1

③ x 2

④ x 2

⑥ x 4

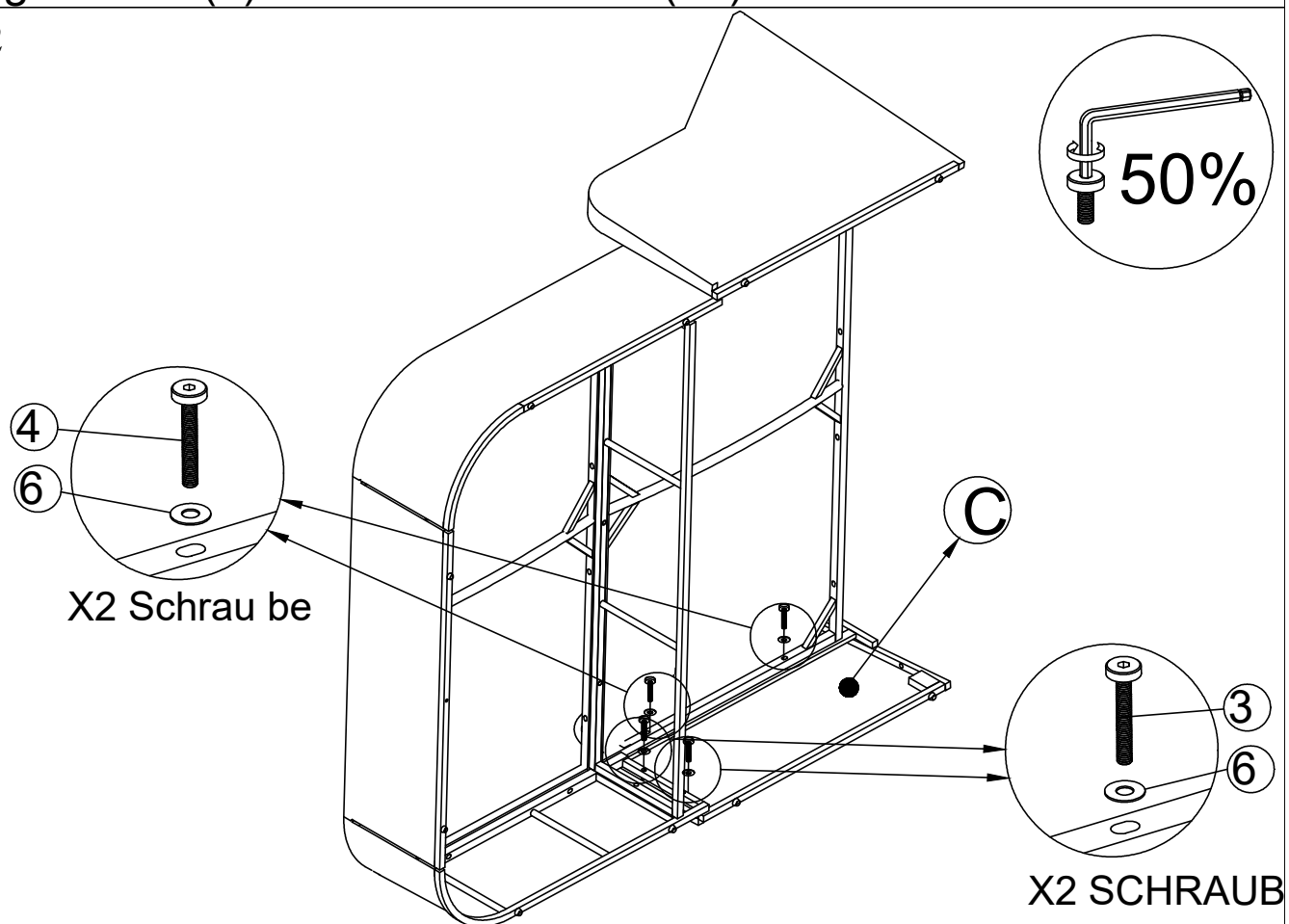

Verbinden Sie das Teil aus Schritt 11 und das Teil aus Schritt 9, ziehen Sie die Schraube (3) an, ziehen Sie die Schraube (4) und die Unterlegscheibe (6) mit dem Inbusschlüssel (12) an.

SCHRITT 13

- E** x 1
- 5** x 4
- 6** x 8
- 9** x 4

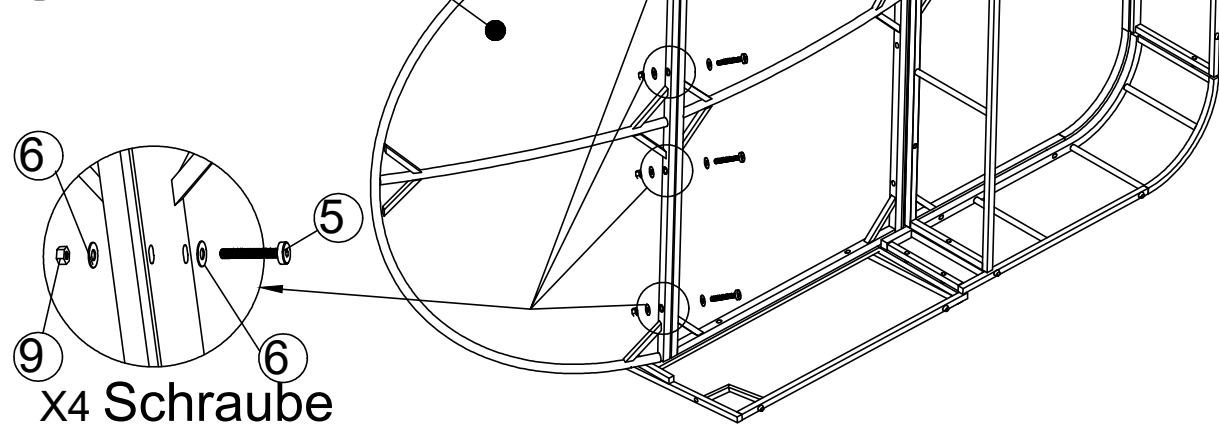

Verbinden Sie das Teil aus Schritt 12 mit der vorderen Sitzbank (E), ziehen Sie die Schraube (5) und die Unterlegscheibe (6) mit dem Inbusschlüssel (12) und dem Schlüssel (11) fest.

SCHRITT 14

- K** x 1
- 4** x 3
- 3** x 2
- 6** x 5

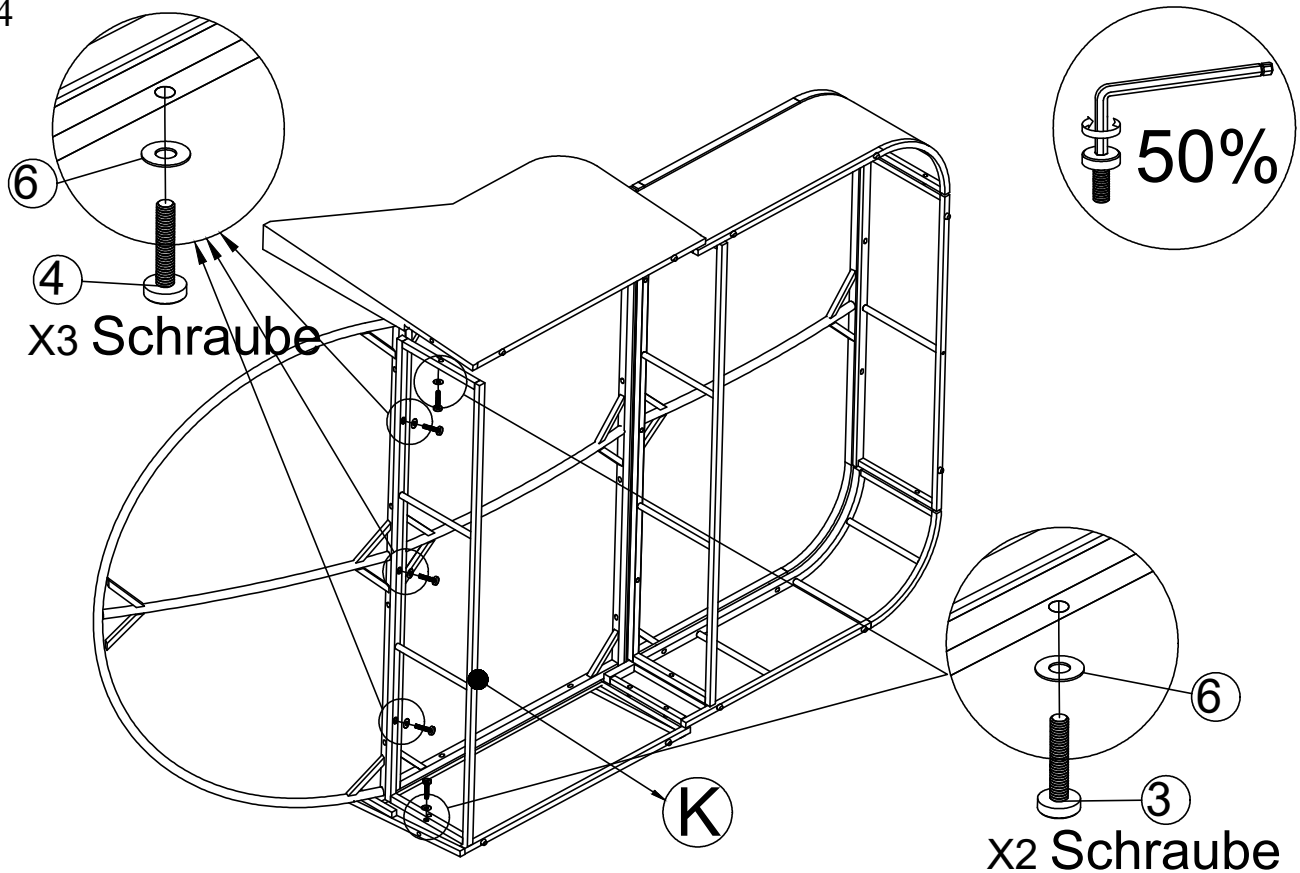

Verbinden Sie das Teil aus Schritt 13 und die vordere Halterung (K) und ziehen Sie Schraube (3), Schraube (4) und Unterlegscheibe (6) mit dem Inbusschlüssel (12) fest.

SCHRITT 15

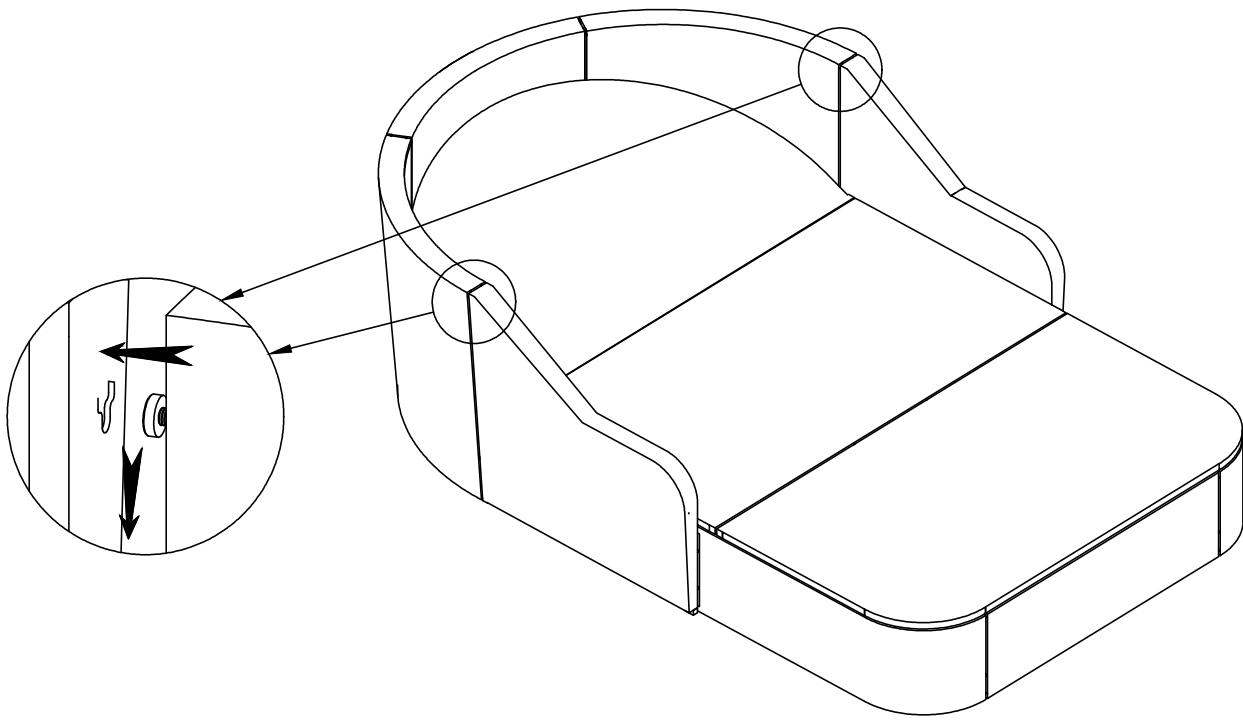

Verbinden Sie das Teil aus Schritt 14 und das Teil aus Schritt 3.

SCHRITT 16

④ x 2

⑥ x 2

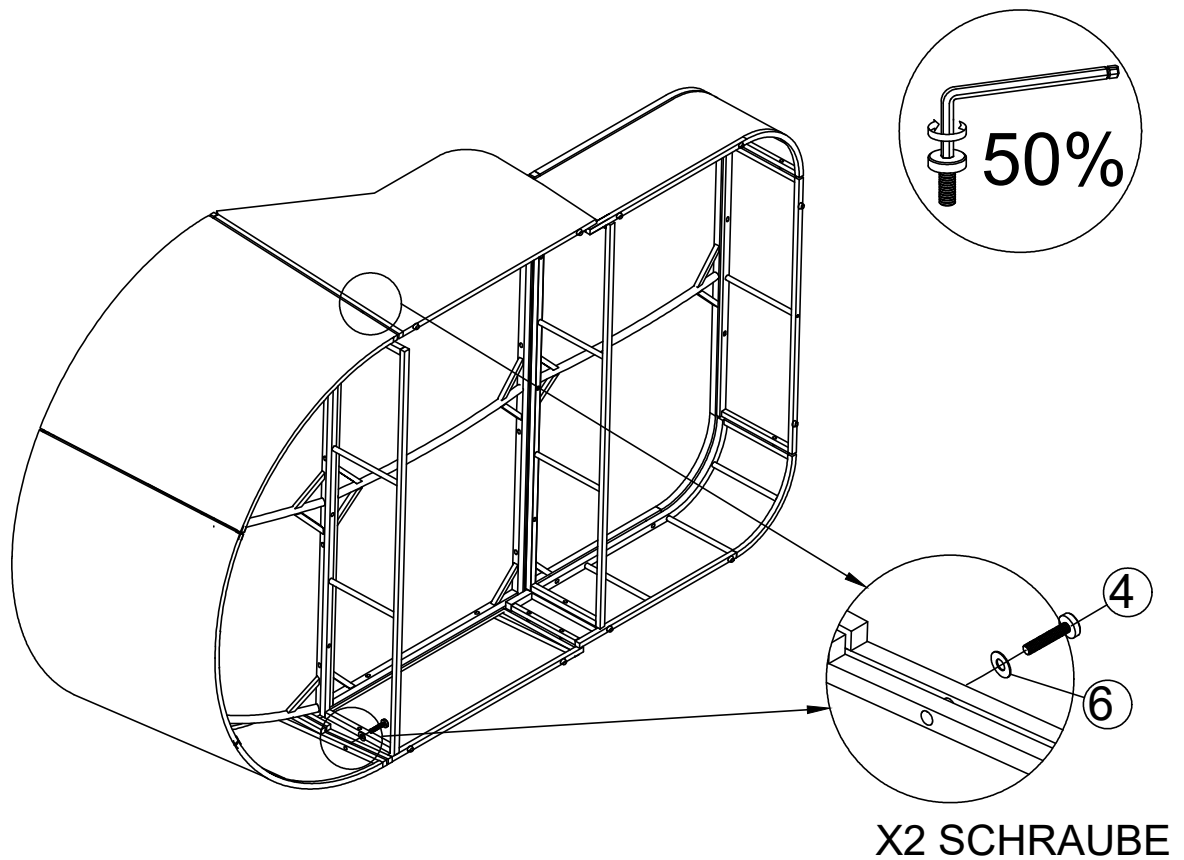

Verbinden Sie das Teil aus Schritt 14 und das Teil aus Schritt 3, ziehen Sie die Schraube (4) und die Unterlegscheibe (6) mit dem Inbusschlüssel (12) fest.

SCHRITT 17

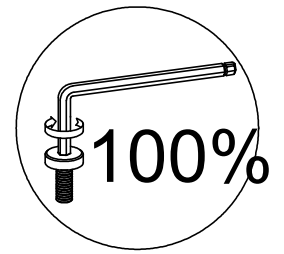
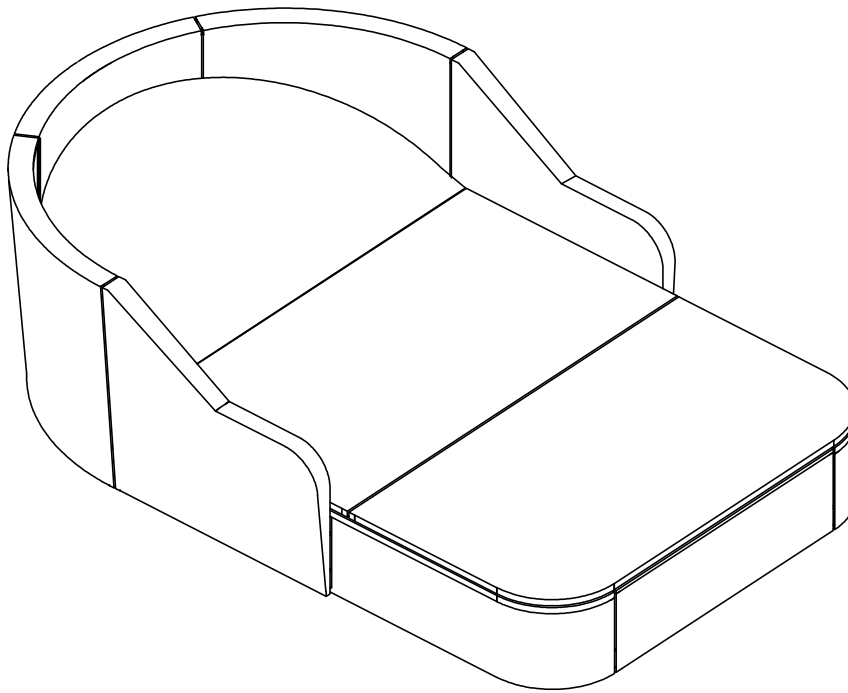

Stellen Sie die Lounge aufrecht hin und vergewissern Sie sich, dass alle Beine waagrecht sind. Ziehen Sie dann die Schrauben mit dem Inbusschlüssel (12) und dem Schlüssel (11) fest an.

SCHRITT 18

- M+ x 1
- M- x 1
- N+ x 1
- N- x 1
- O+ x 1
- O- x 1
- P+ x 1
- P- x 1
- 14 x 4

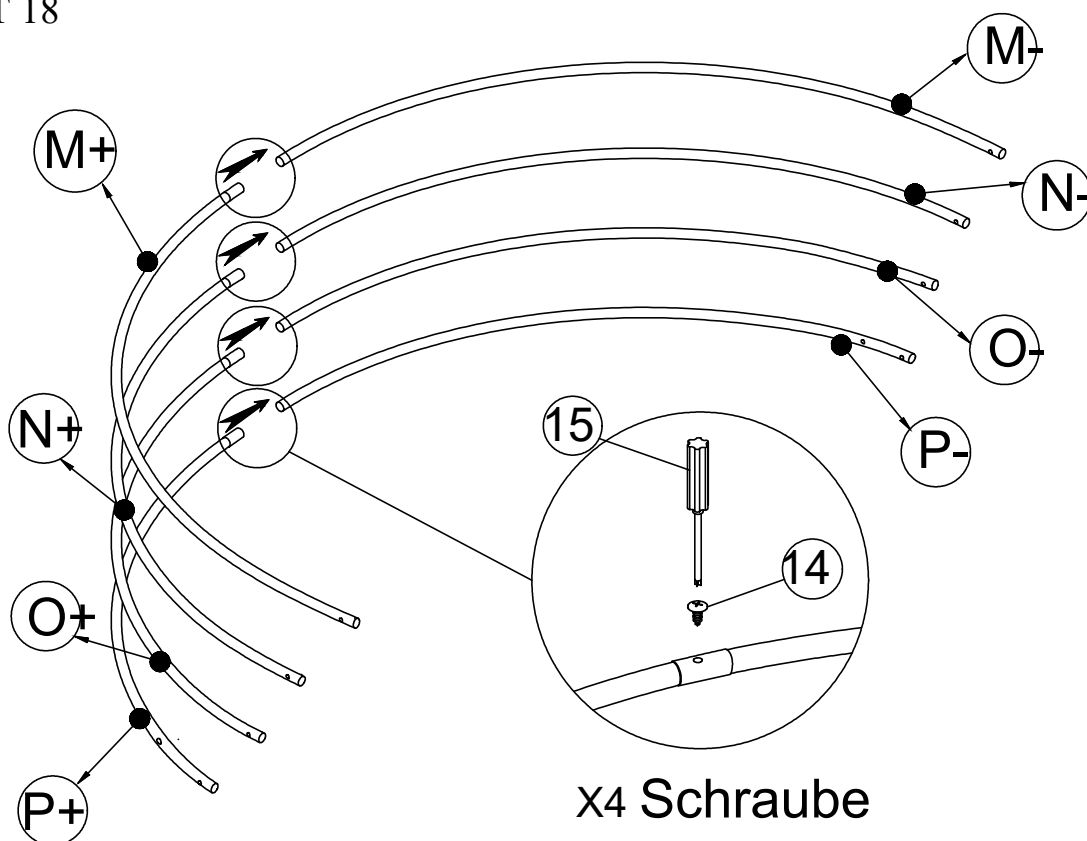

Verbinden Sie den Support M+ & Support M- , Support N+ & Support N- , Stütze O+ & Stütze O- , Stütze P+ & Stütze P-. Schraube (14) mit Schraubendreher (15) festziehen.

SCHRITT 19

M x 1

Q x 1

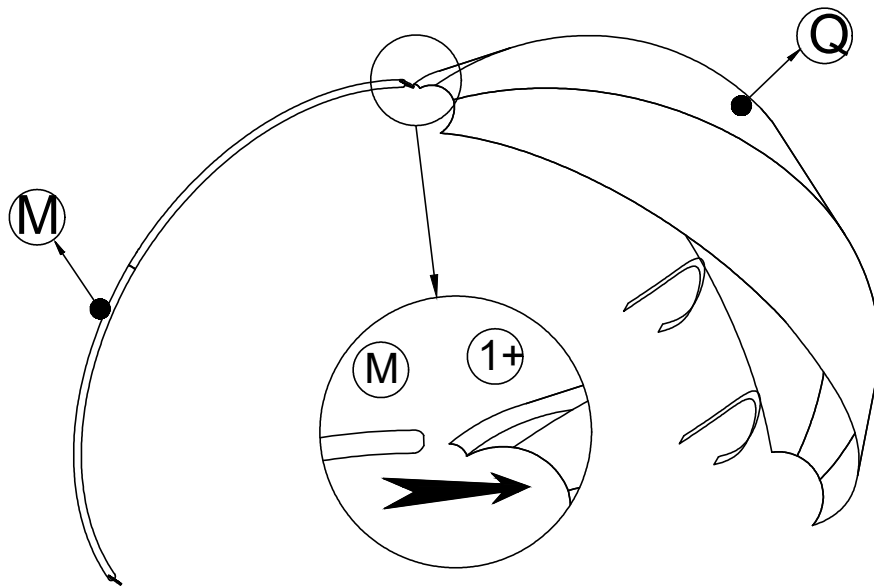

Verbinden Sie die Stütze (M) und die Abdeckung (Q).

SCHRITT 20

N x 1

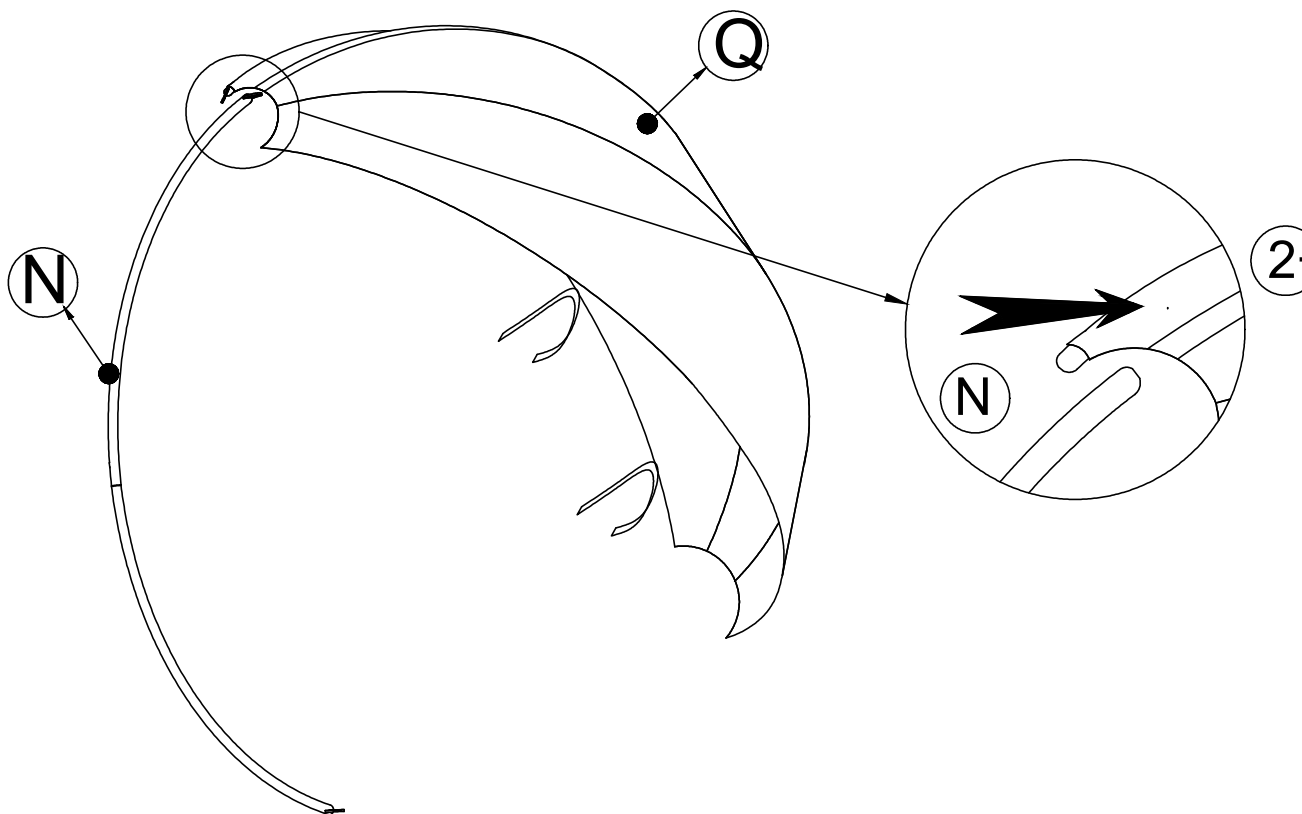

Verbinden Sie das Teil aus Schritt 19 und die Stütze (N)

SCHRITT 21

O x 1

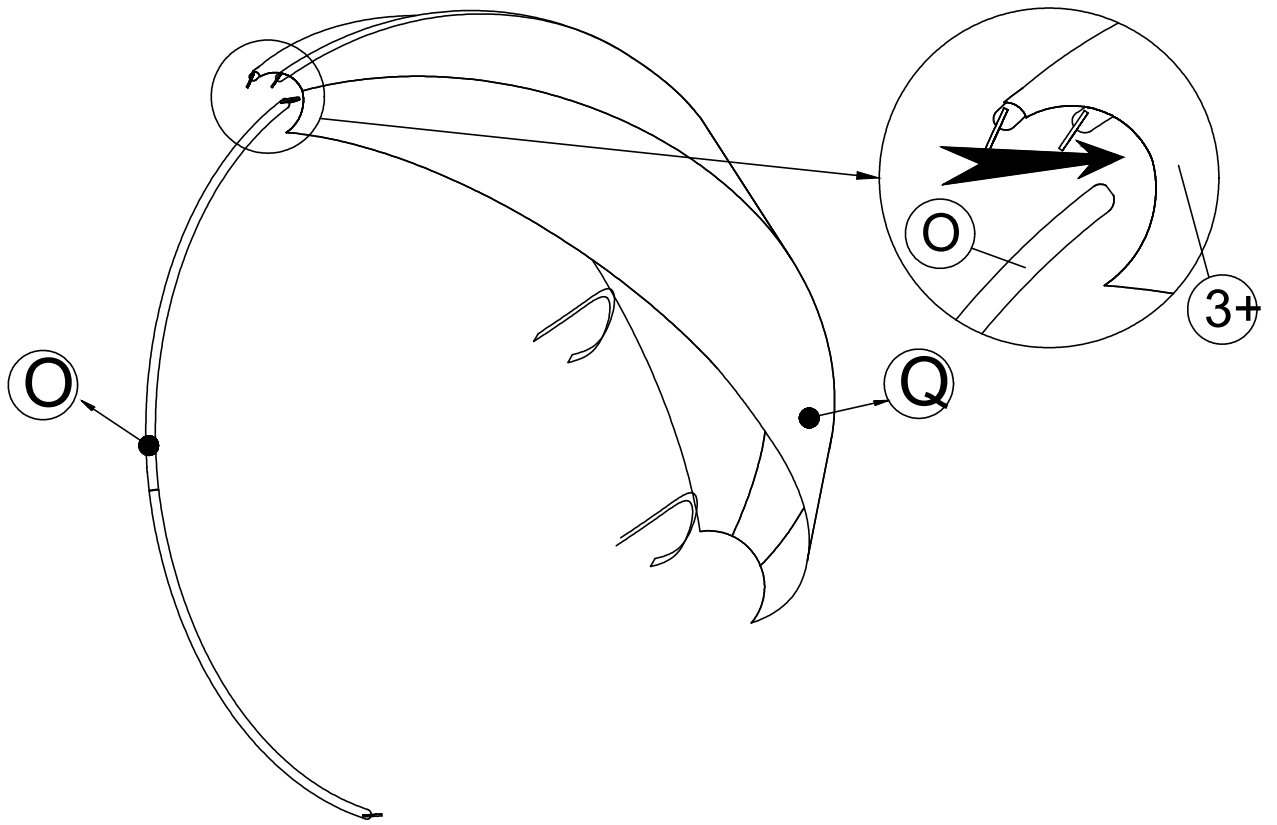

Verbinden Sie das Teil aus Schritt 20 und die Stütze (O)

SCHRITT 22

P x 1

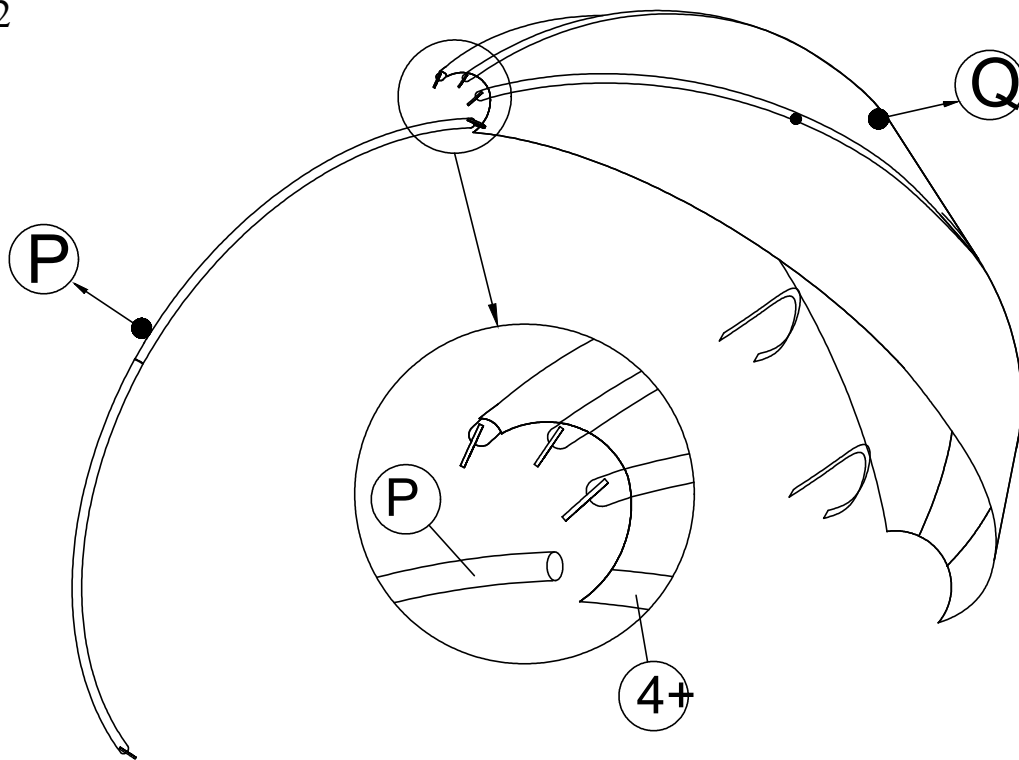

Verbinden Sie das Teil aus Schritt 21 & Stütze (P)

SCHRITT 23

ⓧ x 2

① x 12

⑥ x 12

⑱ x 2

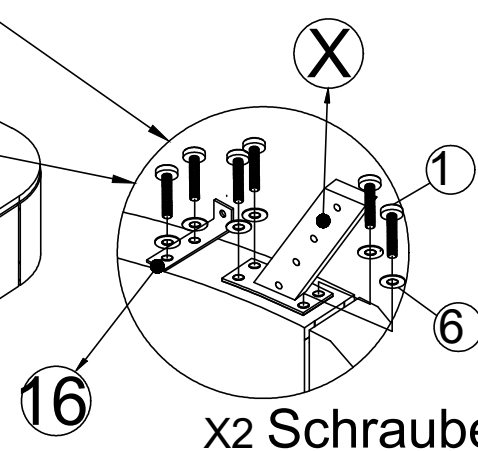
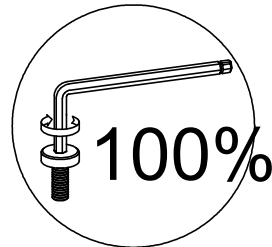
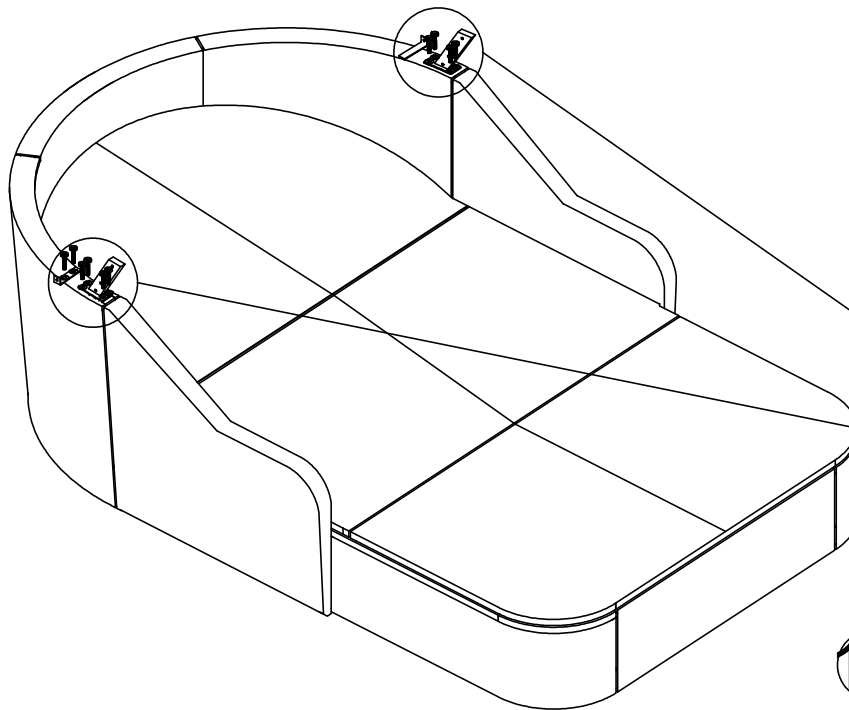

x2 Schraube

Verbinden Sie das Teil aus Schritt 17 mit dem Anschluss A (X) Anschluss (16), ziehen Sie die Schraube (1), die Unterlegscheibe (6) und den Inbusschlüssel (12) fest.

SCHRITT 24

⑥ x 16

⑦ x 8

⑨ x 8

⑱ x 8

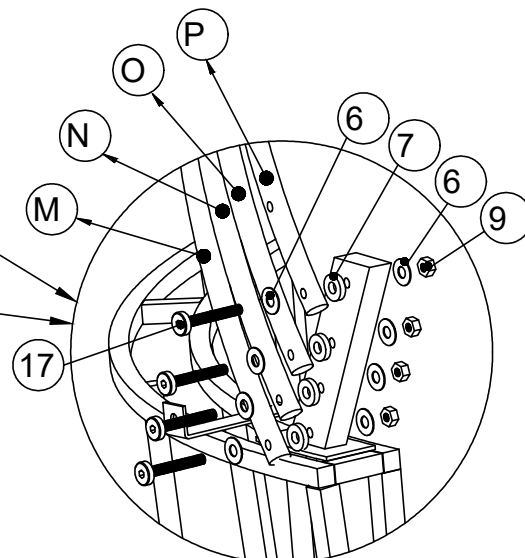
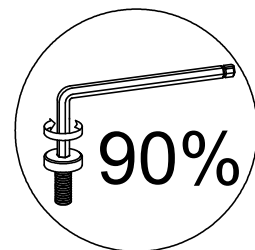
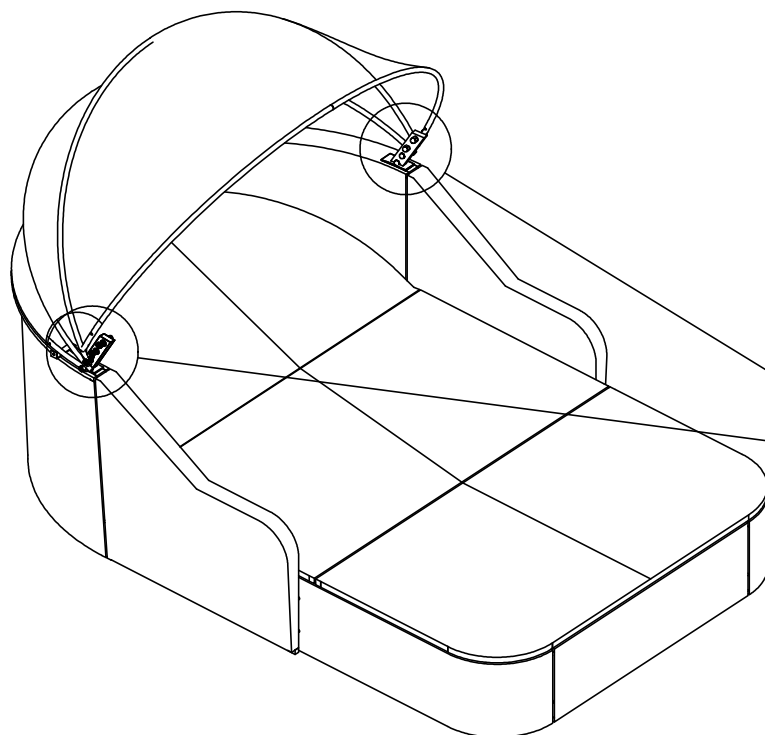

x2 Schraube

Verbinden Sie das Teil aus Schritt 23 und das Teil aus Schritt 22 mit Schraube (17), Unterlegscheibe (6), Unterlegscheibe (7), Inbusschlüssel (9), Inbusschlüssel (12), Schlüssel (11).

SCHRITT 25

- ② x 2
- ③ x 2
- ⑥ x 6
- ⑦ x 2
- ⑧ x 2
- ⑨ x 2
- ⑬ x 2

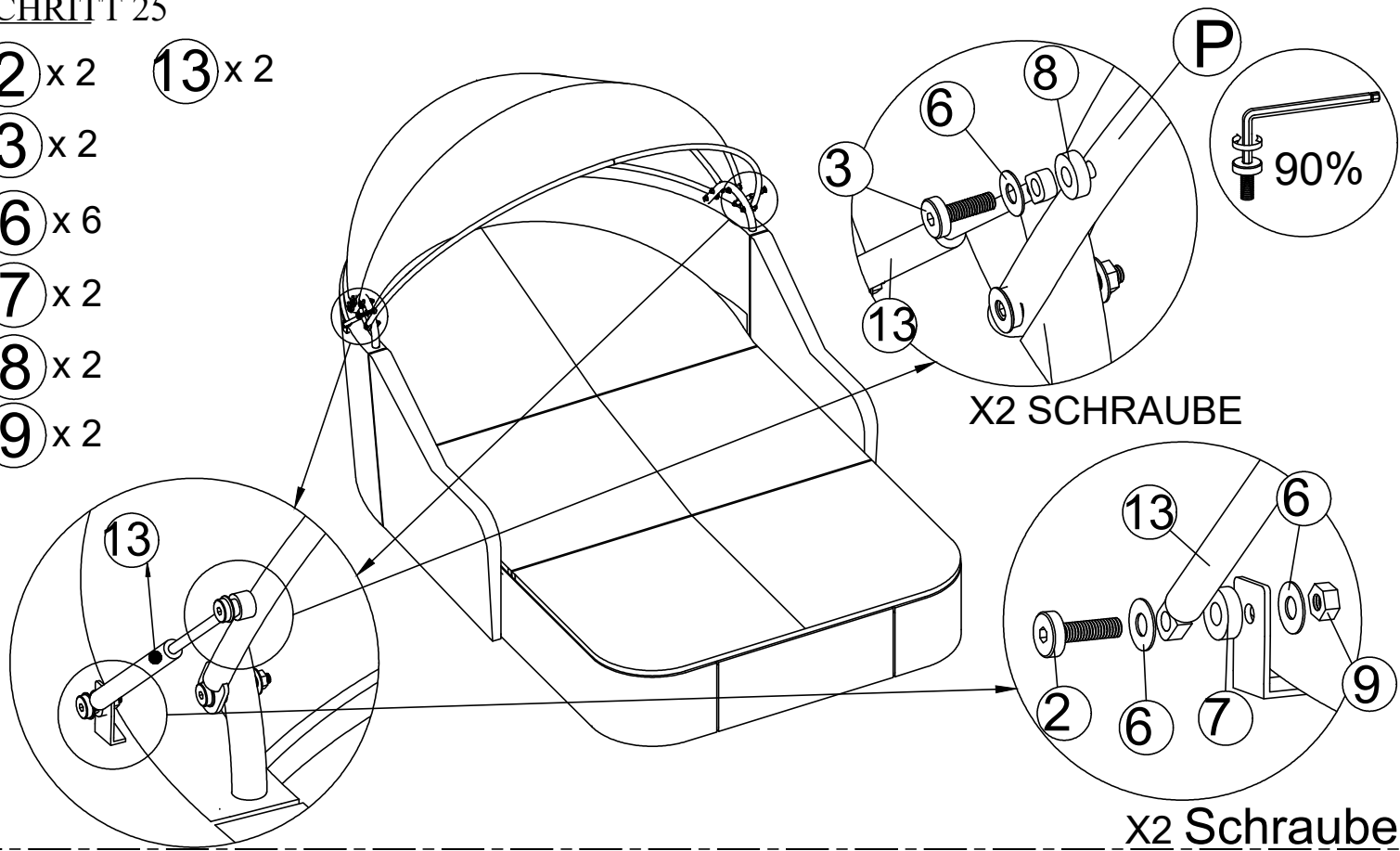

X2 SCHRAUBE

x2 Schraube

Verbinden Sie das Teil aus Schritt 24 und den Gaslift (13), ziehen Sie die Schraube (2) an, die Schraube (3), Unterlegscheibe (6), Unterlegscheibe (7), Unterlegscheibe (8), Mutter (9) mit Inbusschlüssel (12), Schlüssel (11).

SCHRITT 26

- ⑩ x 10
- ⑱ x 12

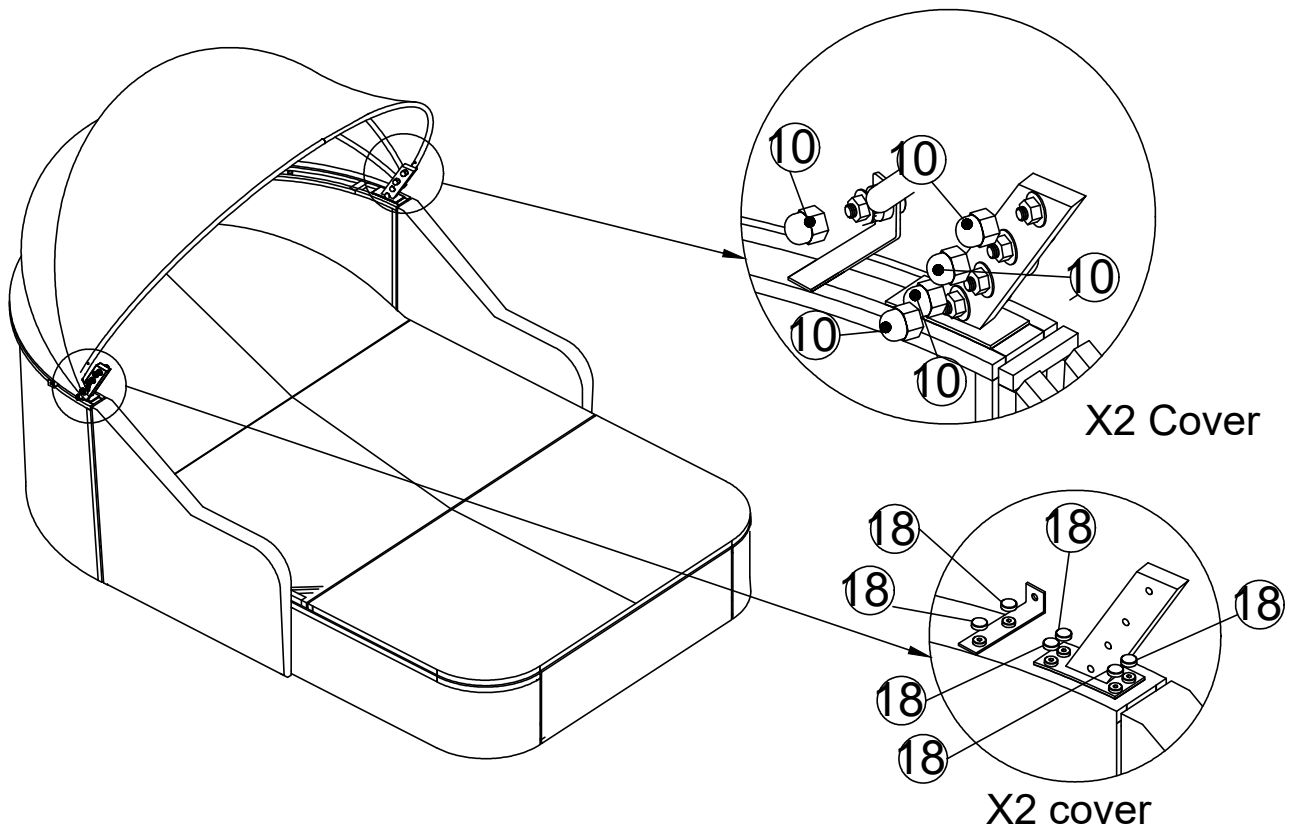

X2 Cover

X2 cover

Verbinden Sie das Teil aus SCHRITT 25 mit der Mutter (10) und dem Deckel (18).

SCHRITT 27

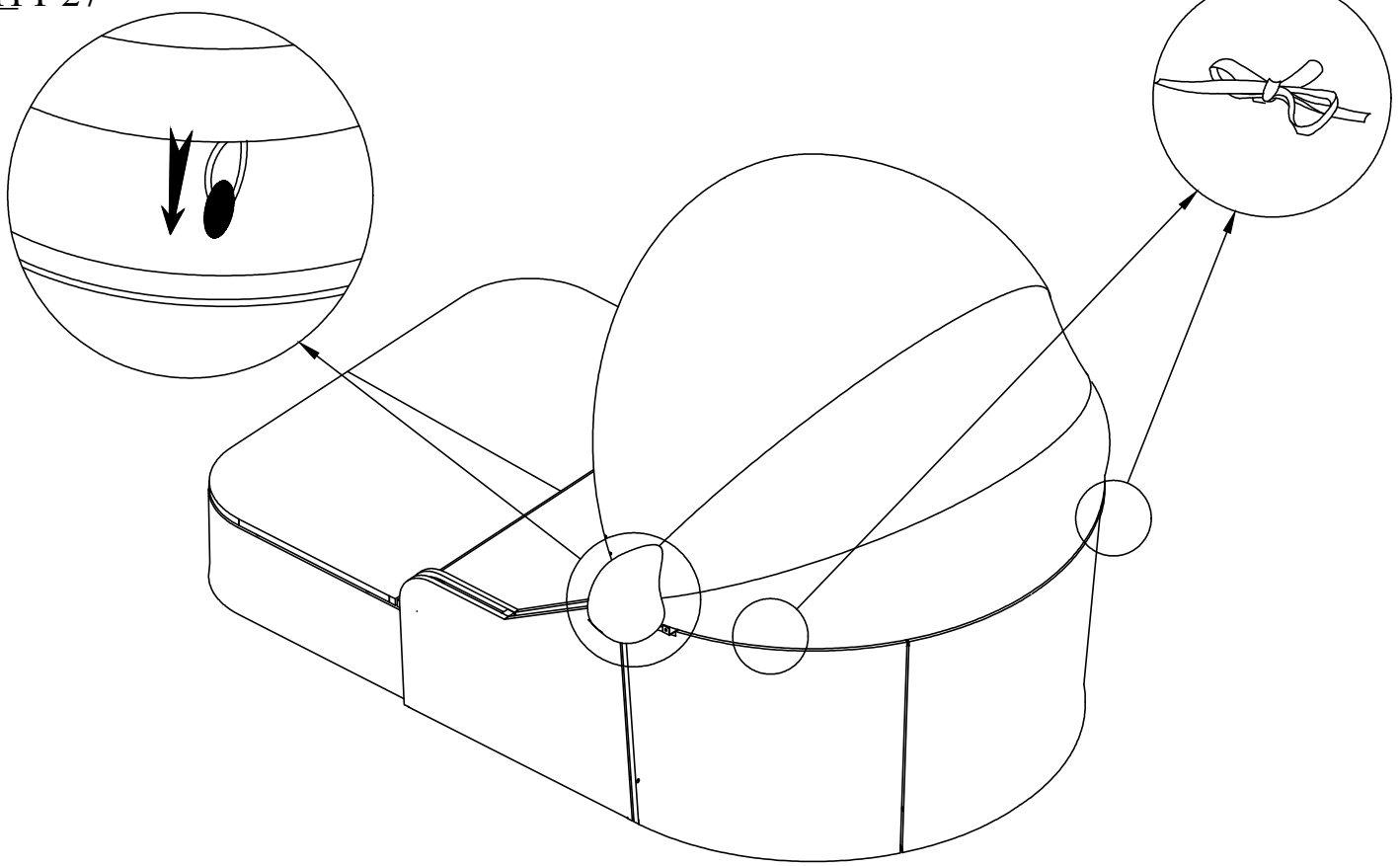

Kleben Sie die Schnur an die abgedeckte Back Lounge.

SCHRITT 28

U x 1
V x 1

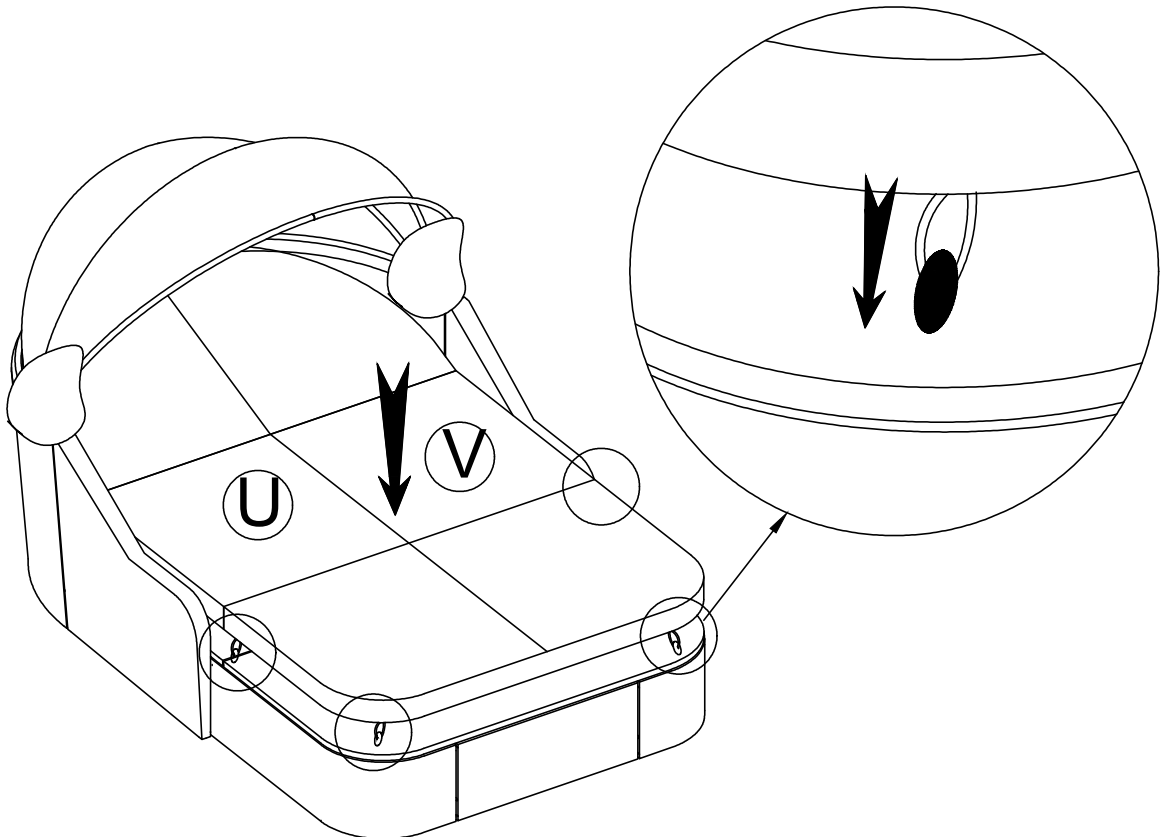

Legen Sie das Sitzkissen rechts (U) und das Sitzkissen links (V) auf das Sofa. Schnur an Lounge befestigen.

SCHRITT 29

(S) x 2

(T) x 2

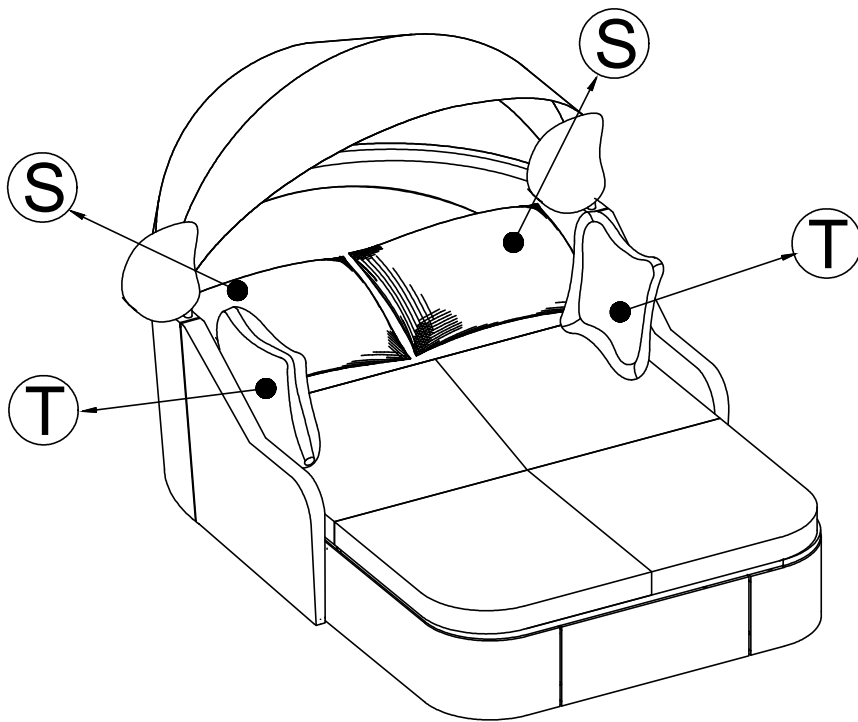

Legen Sie das Rückenkissen (S) und das Pillow-Kissen (T) auf die Liege.

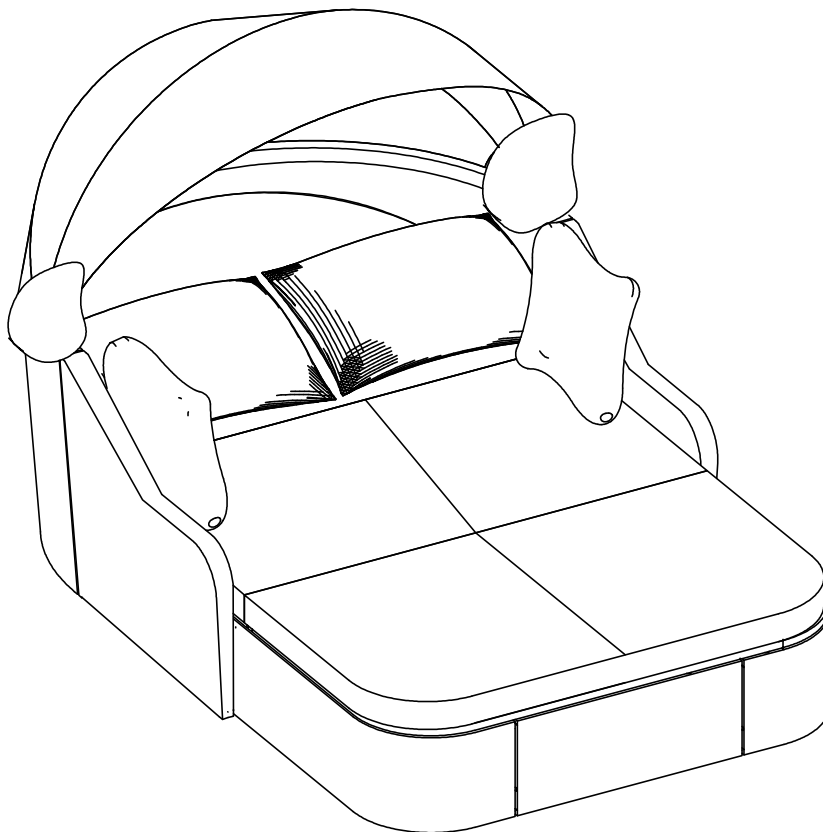

Finish Lounge