









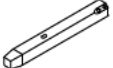
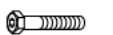

ASSEMBLY INSTRUCTIONS

NO.	Parts List		Q' TY	NO.	Hardware list		Q' TY
A		ChairBack	1	1		5/16"*3-1/8" Allen Bolts	4
B		ChairSeat	1	2		5/16"*2-1/4" Allen Bolts	4
C		Right Front Leg	1	3		5/16"*1-1/2" Allen Bolts	3
D		Left Front Leg	1	4		Spring Washers (8mm)	11
E		Right Stretcher	1	5		Flat Washers(8*19*2mm)	11
F		Left Stretcher	1	6		#8x 1-1/2" Wood Screw	4
				7		Allen Key (4mm)	1



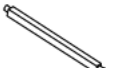

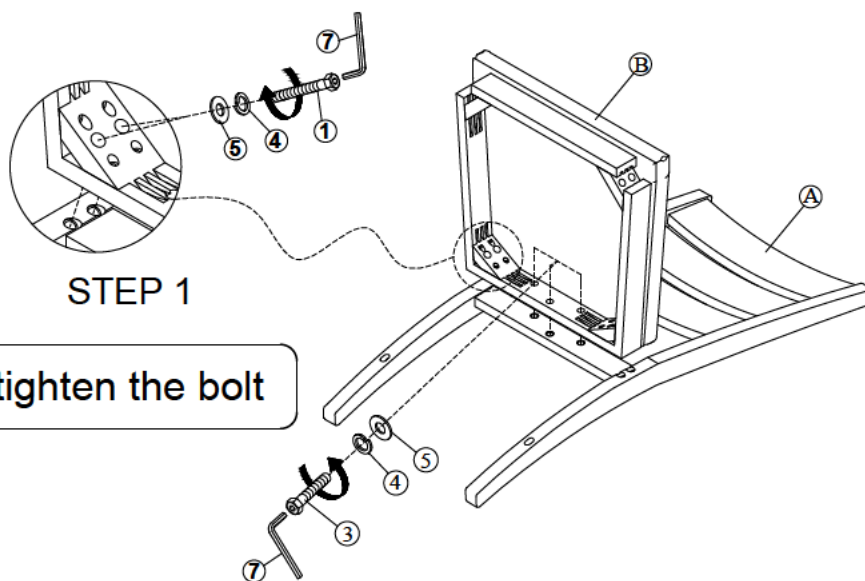
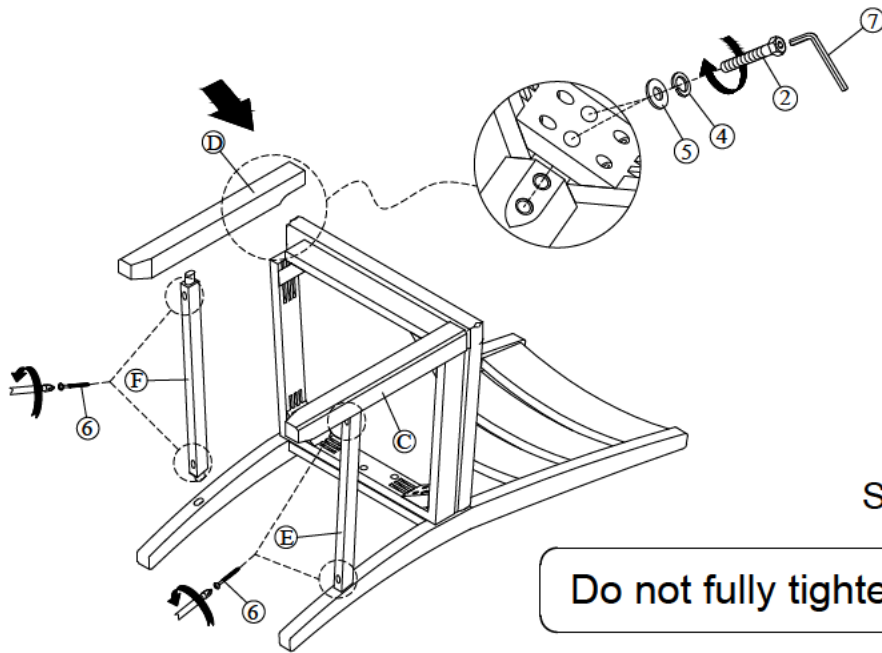
STEP 2

Do not fully tighten the bolt

STEP 3

Levelling solution: Loosen each bolt in the seat box (front legs, back corner blocks and back apron) to the point where it can be turned with our □ fingers. Place the Chair upright on the floor and make sure Chair/Stool back and seat frame are well connected. Sit in the Chair/Stool, but do not lean against the Chair/Stool back. Gently sway back and forth, left and right. Carefully turn the Chair/Stool upside down, and tighten each bolt. The Chair/Stool will now be levelled.

