

Ax2



Bx3



Cx1

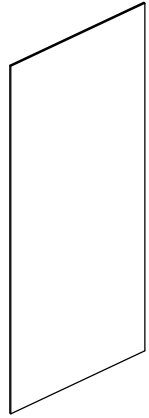

Dx3

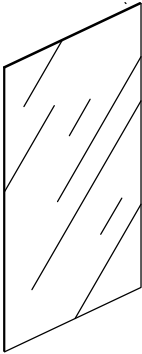

Ex2

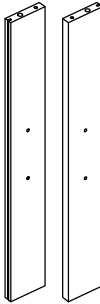

Fx2

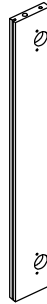

Gx2



Hx4



Ix8
M8x⁵⁰_{1.97}



Jx16
M8x³⁵_{1.38}



Kx20

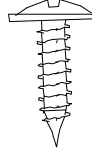

Lx1



Mx20

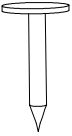

Nx30



Ox24

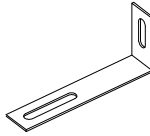

Px1

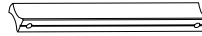

Qx2

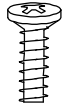

Rx4

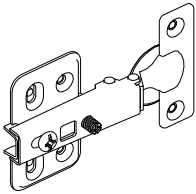

Sx4



Tx1



Ux1

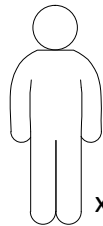
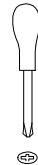
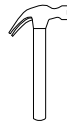

mm
inch



x2

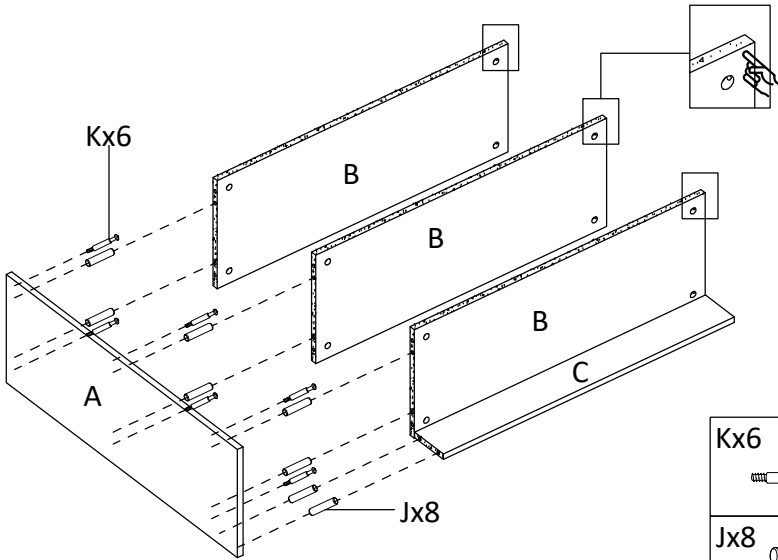

€ £

1



Kx6	
Jx8	
M8x	$\frac{35}{1.38}$

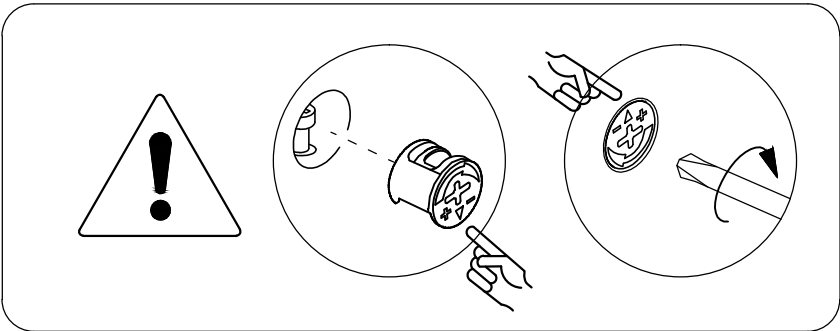

②

Mx6

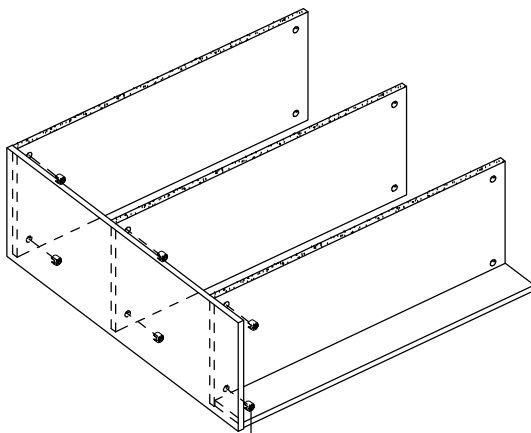

Mx6

③

Kx6



Jx8



M8x $\frac{35}{1.38}$

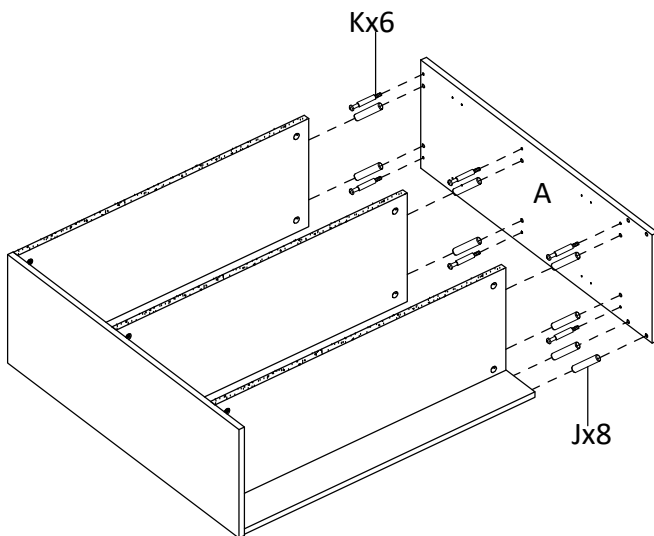

Kx6

A

Jx8

4

Mx6

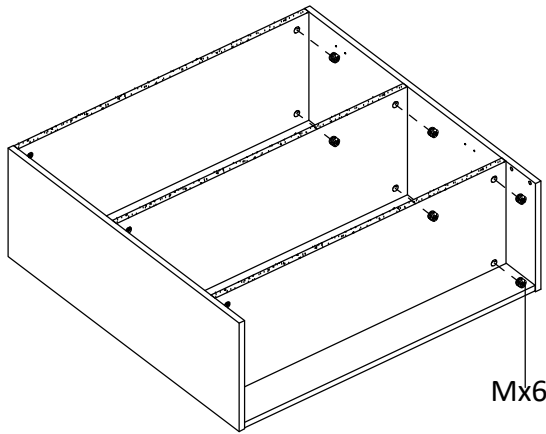

Mx6

5

Nx30

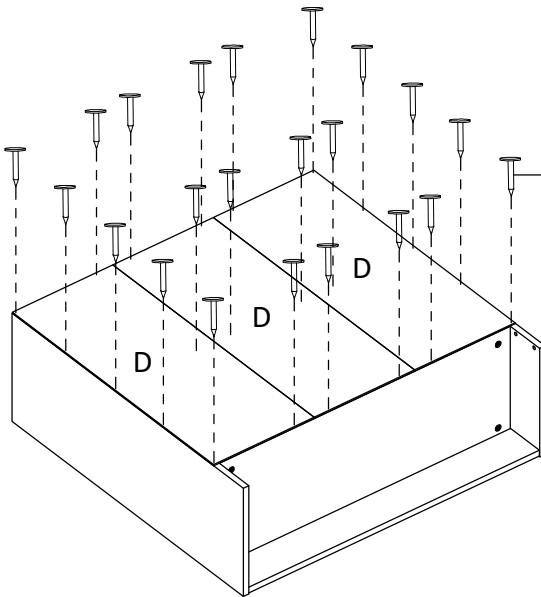

Nx30

6

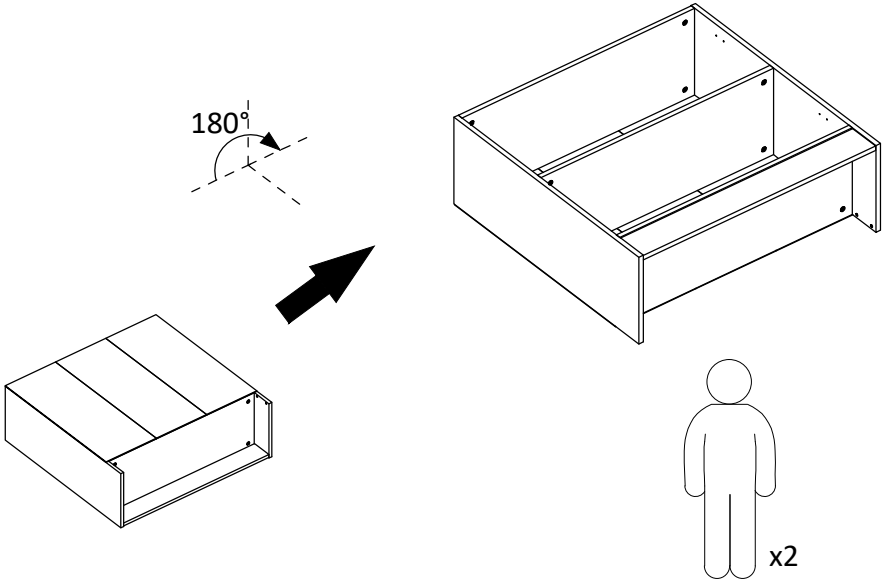

7

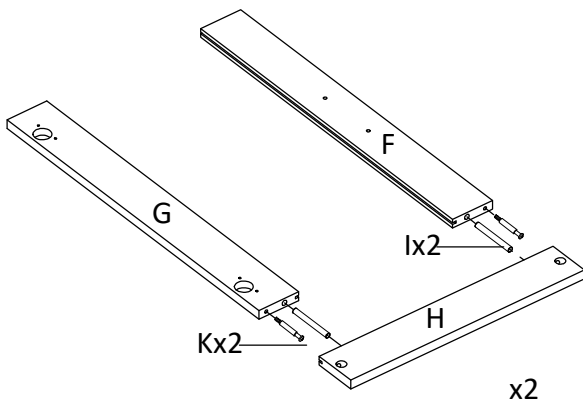

Kx4



Ix4



M8x $\frac{50}{1.97}$

8

Mx4

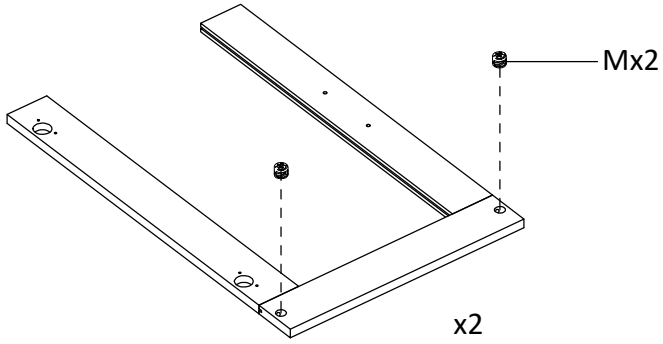

9

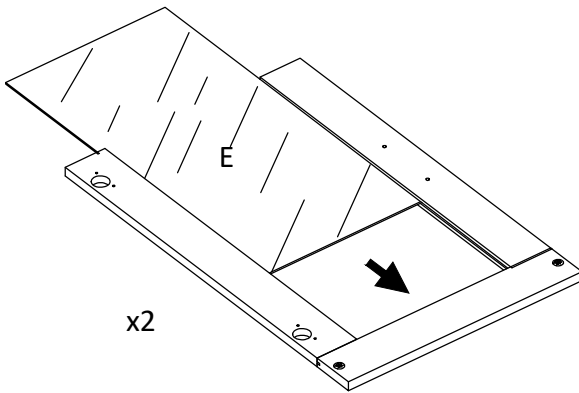

10

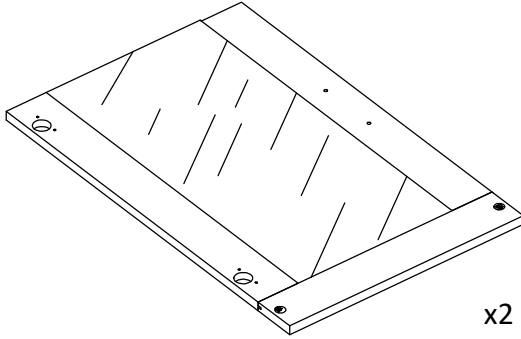

11

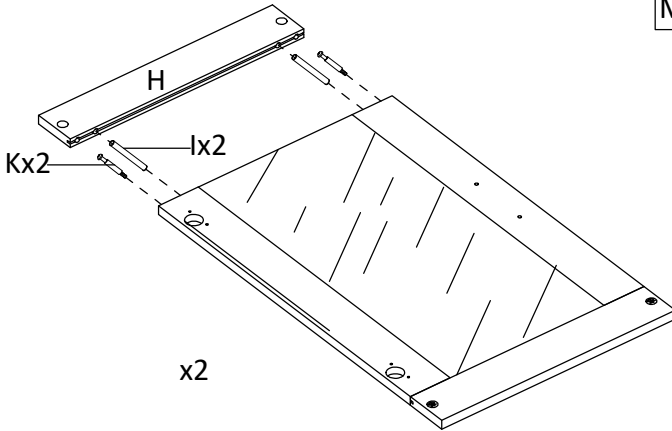

Kx4



Ix4



M8x $\frac{50}{1.97}$

12

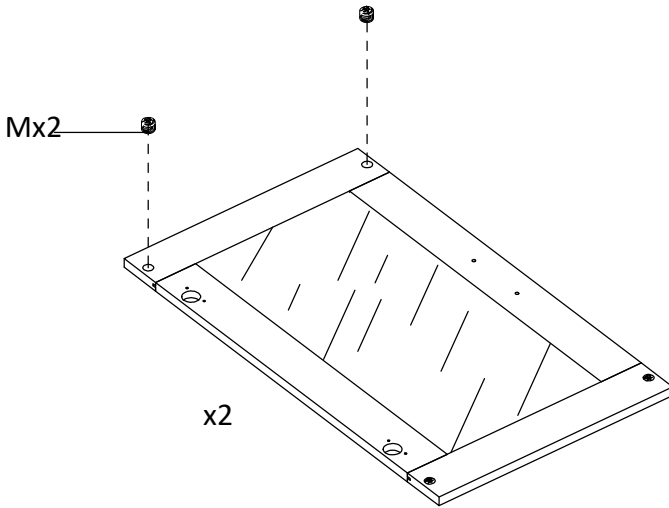

Mx4



13

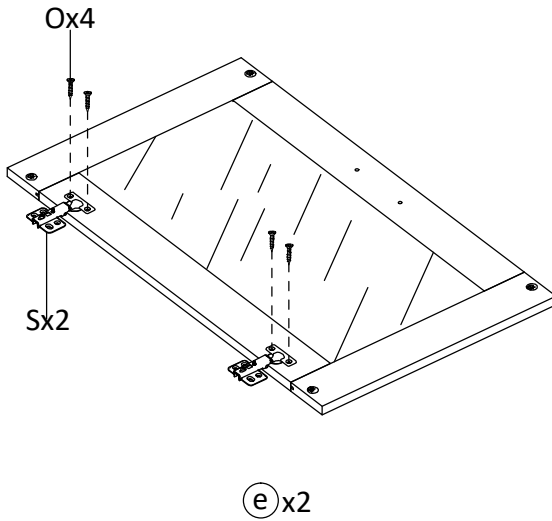

Sx4





Ox8



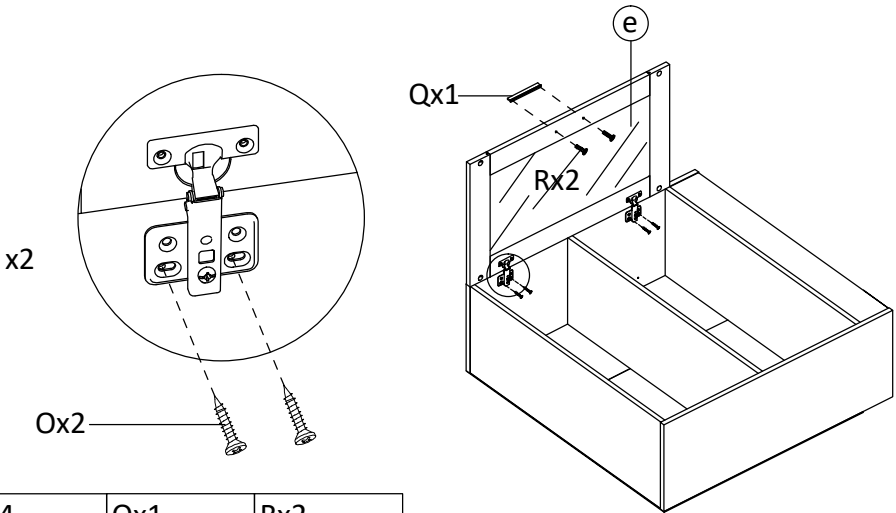



14

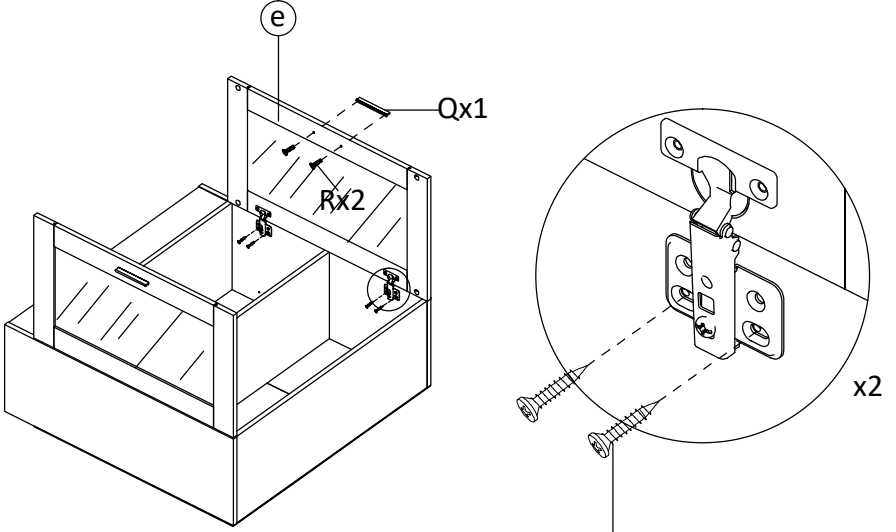

Ox4	Qx1	Rx2
		

15



Ox4	Qx1	Rx2
		

16

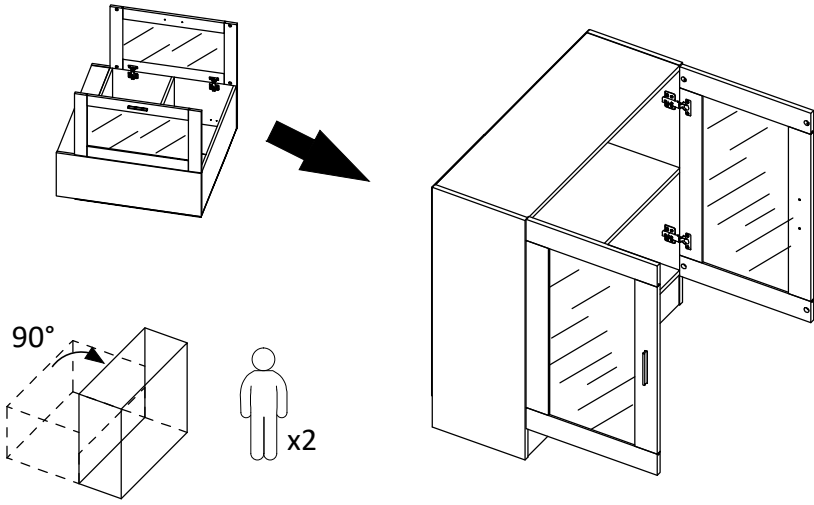

17

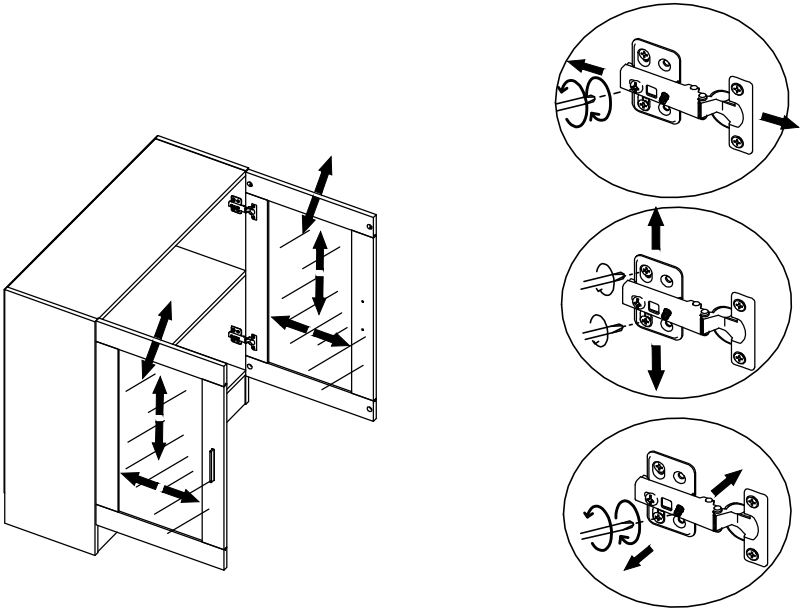

18

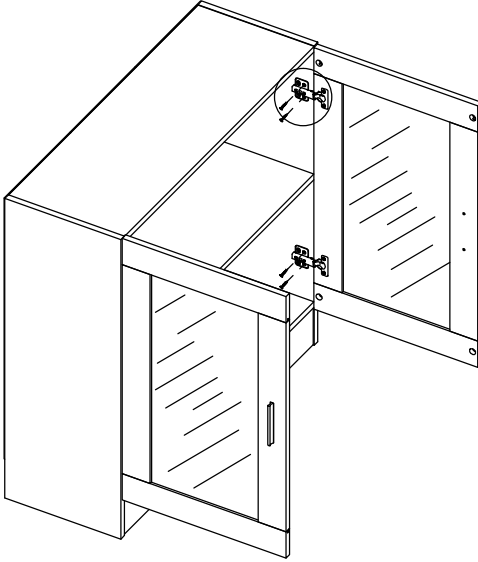

Ox4

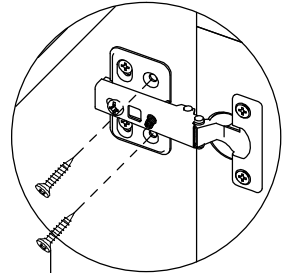

x2

Ox2

19

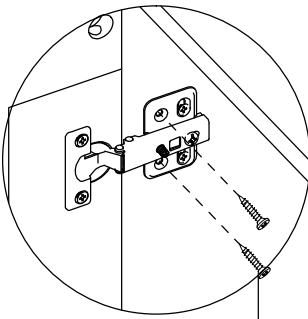

x2

Ox2

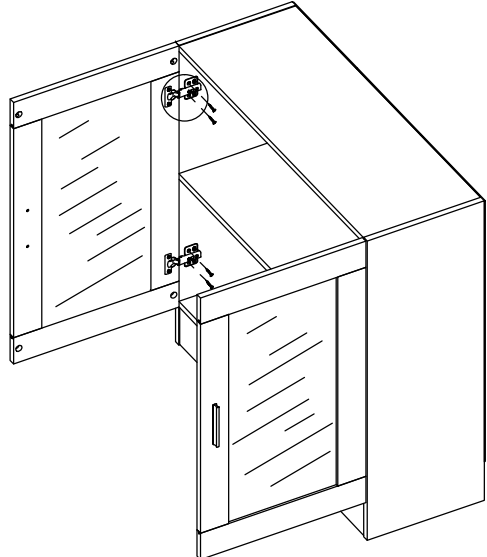



Ox4

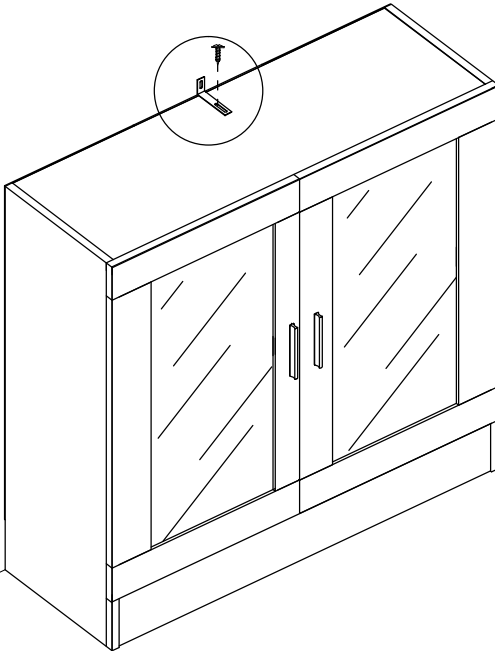
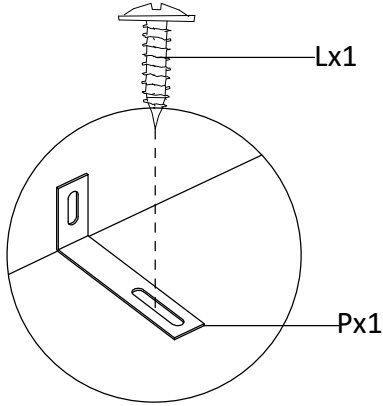

20



Px1	
Lx1	

21

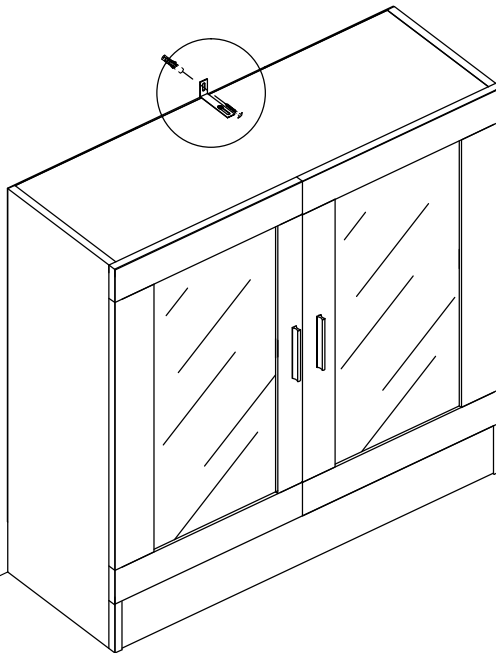
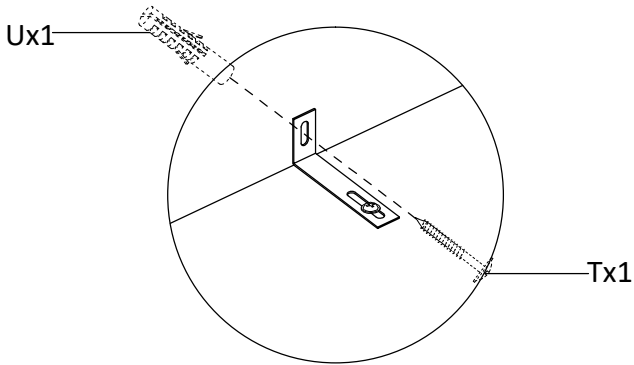

Tx1



Ux1



EN Warning

Serious or fatal crushing injuries can occur from furniture tip over. In order to prevent overturning, this product must be used with the wall attachment device provided. To help prevent tip over:

- Install wall attachment device provided.
- Place heaviest items on the bottom of this product.
- Do not set heavy objects on top of this product.
- Never allow children to climb or hang on doors or shelves.
- Use of wall attachment device will reduce, but not eliminate the risk of tipping.

Important

- Installation should be carried out exactly according these instructions – otherwise a safety risk can occur if incorrectly installed.
- Regularly check that anchors are securely maintained.
- Stability of tall items may be affected by thick pile carpet or uneven floors.
- A wall attachment device is provided with your product; however, you will need to source suitable fixings for your wall type.
- Check for any electrical wires or plumbing inside the wall before drilling any holes (if you are unsure please seek professional advice from a qualified tradesperson).
- Your local hardware store will have the necessary drills and fixings and can offer advice if needed. If in doubt, engage the services of a qualified tradesperson to install and anchor the product.

DE Hinweis

Schwere oder tödliche Verletzungen können durch Umkippen des Möbelstückes verursacht werden. Zur Verhinderung des Umkippens muss dieses Produkt mit dem mitgelieferten Wandbefestigungsgerät benutzt werden. Zur Verhinderung des Umkippens:

- Montieren Sie das mitgelieferte Wandbefestigungsgerät.
- Legen Sie die schwersten Gegenstände auf die Unterseite dieses Produkts.
- Stellen Sie keine schwere Gegenstände auf die Oberseite dieses Produkts.
- Erlauben Sie Kindern niemals, auf die Türen oder Regale zu klettern oder sich an ihnen festzuhalten.
- Der Einsatz des Wandbefestigungsgeräts reduziert die Kippgefahr, beseitigt sie aber nicht.

WICHTIG

- Die Installation sollte genau nach diesen Anweisungen durchgeführt werden - sonst kann bei fehlerhafter Installation ein Sicherheitsrisiko auftreten.
- Überprüfen Sie regelmäßig, ob die Dübel gesichert sind.
- Die Stabilität von hohen Gegenständen kann durch dickflorige Teppiche oder unebene Böden beeinträchtigt werden.
- Ein Wandbefestigungsgerät wird zusammen mit dem Produkt geliefert; Sie müssen jedoch für Ihre Wandart geeignete Befestigungselemente selbst beschaffen.
- Überprüfen Sie, ob es elektrische Leitungen oder Rohre innerhalb der Wand gibt, bevor Sie jegliche Löcher bohren (wenn Sie nicht sicher sind, bitte wenden Sie sich an einen qualifizierten Fachhandwerker für professionelle Beratung).
- Sie werden die notwendigen Bohrer und Befestigungen bei Ihrem örtlichen Haushaltswarenladen finden. Dort können Sie, falls notwendig, auch Beratung erhalten. Im Zweifelsfall wenden Sie sich an einen qualifizierten Fachhandwerker für die Montage und Verankerung des Produkts.

FR Avertissement

Des blessures par écrasement graves ou mortelles peuvent survenir à la suite de renversement du meuble. Afin d'éviter le renversement, ce produit doit être utilisé avec le dispositif de fixation murale fourni. Pour

aider à prévenir les renversements:

- Installer le dispositif de fixation murale fourni.
- Placer les articles les plus lourds en bas de ce produit.
- Ne pas placer d'objets lourds sur le dessus de ce produit.
- Ne jamais permettre aux enfants de grimper ou de s'accrocher aux portes ou aux étagères.
- L'utilisation d'un dispositif de fixation murale réduira mais n'éliminera pas le risque de basculement.

IMPORTANT

- L'installation doit être effectuée exactement selon ces instructions - sinon, un danger pour la sécurité peut survenir en cas d'installation incorrecte.
- Vérifier régulièrement que les ancrages soient maintenus de manière sûre.
- La stabilité des articles de grande taille peut être affectée par une moquette épaisse ou par des planchers inégaux.
- Un dispositif de fixation murale est fourni avec votre produit ; Cependant, vous aurez besoin d'acheter des fixations adaptées à votre type de mur.
- Vérifiez s'il y a des fils électriques ou de la plomberie à l'intérieur du mur avant de percer des trous (si vous n'êtes pas sûr, veuillez consulter un professionnel qualifié).
- Votre quincaillerie locale aura les perceuses et les fixations nécessaires et pourra vous conseiller si nécessaire. En cas de doute, faites appel aux services d'un professionnel qualifié pour installer et ancrer le produit.

NL Waarschuwing

Er kunnen serieuze of fatale verwondingen ontstaan als het meubel omvalt. Om te voorkomen dat het omvalt, moet het product in combinatie met de meegeleverde wandbevestiging worden gebruikt. Om omvallen te helpen voorkomen:

- Installeer de meegeleverde wandbevestiging.
- Plaats de zwaarste voorwerpen onderop.
- Plaats geen zware voorwerpen bovenop dit product.
- Sta nooit toe dat kinderen op de deuren of planken klimmen of hangen.
- Het gebruik van de wandbevestiging zal het risico op omvallen verminderen, maar niet uitsluiten.

BELANGRIJK

- Installatie moet exact volgens deze instructies worden uitgevoerd - er kan een veiligheidsrisico ontstaan wanneer het niet correct is geïnstalleerd.
- Controleer regelmatig of de verankering nog in goede staat verkeert.
- De stabiliteit van producten kan worden beïnvloed door dik tapijt of ongelijke vloeren.
- Er wordt een wandbevestiger bij het product geleverd; u moet echter zelf zorgen voor de geschikte bevestigingsmaterialen voor uw wandtype.
- Controleer voordat u gaten in de muur boort op elektrische bedradingen en leidingen in de muur (als u het niet zeker weet, vraag dan hulp aan een professionele vakman).
- De lokale doe-het-zelfzaak zal de benodigde boren en bevestigingsmaterialen kunnen leveren en eventueel advies kunnen geven, indien dat nodig is. Neem bij twijfel een erkende vakman in de arm om het product te installeren en te verankeren.

IT Avvertimento

Si possono verificare lesione gravi o fatali in caso di ribaltamento del mobile. Per evitare questo problema il prodotto deve essere sempre utilizzato con il dispositivo di fissaggio a muro fornito. Per prevenire il ribaltamento:

- Installare il dispositivo di fissaggio a muro fornito.
- Posizionare gli oggetti più pesanti sul fondo di questo prodotto.