





















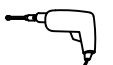

ASSEMBLY INSTRUCTIONS

PAGE: 1/5

Before you begin, please follow assembly instructions carefully, then follow them step by step.

Read instruction carefully . See Furniture Parts list and Hardware List for guidance . Be sure you have all parts before you start assembling . Place and assemble furniture on a clean flat soft surface , such as carpet or rug to prevent being scratched .

PART LIST		QTY	HARDWARE		
1	TOP PANEL	1 PC	A	MINI FIX A1  A2  A3 	14 PCS
2	BOTTOM PANEL	1 PC	B	M8 X 30MM WOOD DOWEL 	20 PCS
3	SIDE PANEL (L)	1 PC	C	M6 X 50MM CSK CAP WOOD SCREW 	6 PCS
4	SIDE PANEL (R)	1 PC	D	M3.5 X 16MM C.B SCREW 	24 PCS
5	CENTER PANEL	1 PC	E	M4 X 32MM C.B SCREW 	4 PCS
6	MIDDLE PANEL	2 PCS	F	ALLEN KEY M4 	1 PC
7	SHELF PANEL	6 PCS	G	5/8 NAIL 	40 PCS
8	BACK PANEL	1 PC	H	SOFT CLOSING 7/8 HINGES 	4 PCS
9	DOOR PANEL (L)	1 PC	I	METAL SHELF SUPPORT 	24 PCS
10	DOOR PANEL (R)	2 PCS	J	WOOD HANDLE (SMALL) 	2 PCS
11	LEG (L)	2 PCS	K	JCBC SCREW M6 X 40MM 	8 PCS
12	LEG (R)	2 PCS	L	SPRING WASHER M6 	8 PCS
SELF-PREPARED TOOLS: Tools below are NOT included in package.			M	FLAT WASHER M6 	8 PCS
 SCREWDRIVER			 HAMMER		
 POWER DRILL			N TIPPING PACK  N1  N3  N5  N2  N4  2 SETS		

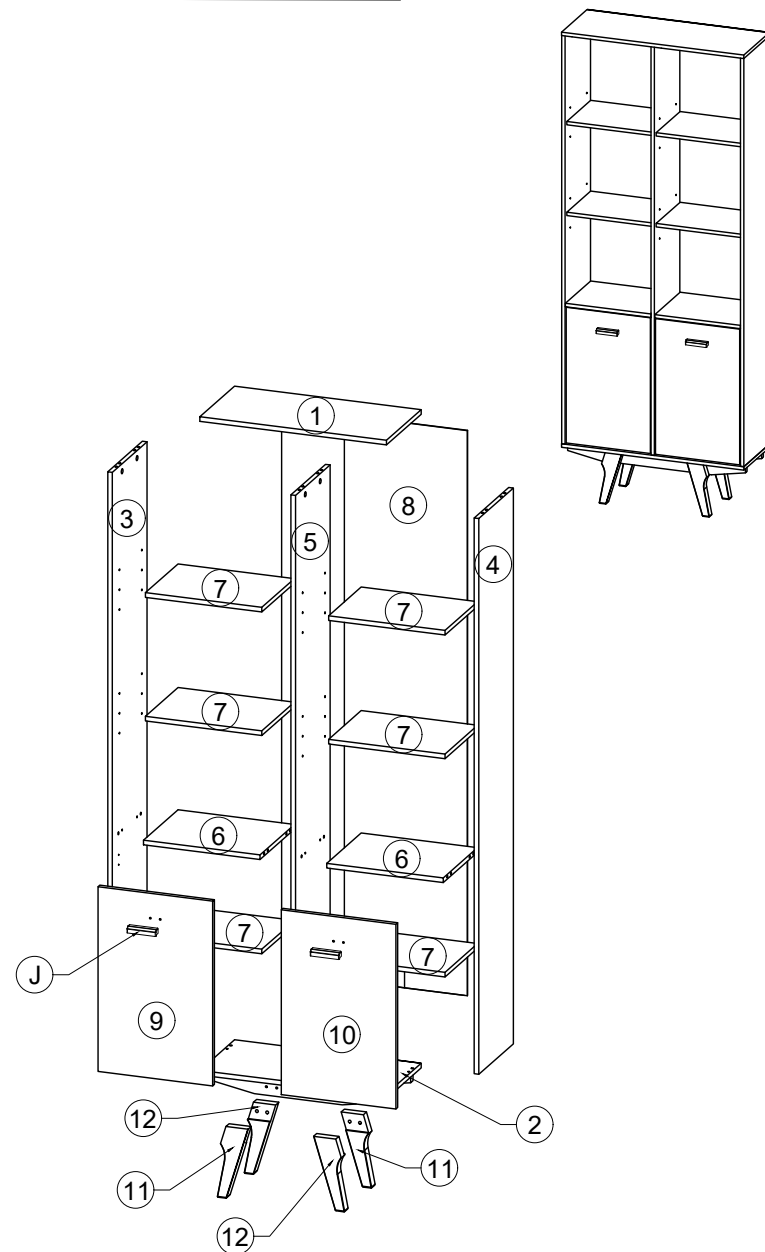

Reminder:

Please ensure that all surfaces and edges with colours/laminations are facing forward/outward.

ASSEMBLY INSTRUCTIONS

STEP 1

- Insert hardware **A2** onto panel **(1)**.
(Repeat 8 times.)
- Insert hardware **A2** onto panel **(5)**.
(Repeat 2 times.)

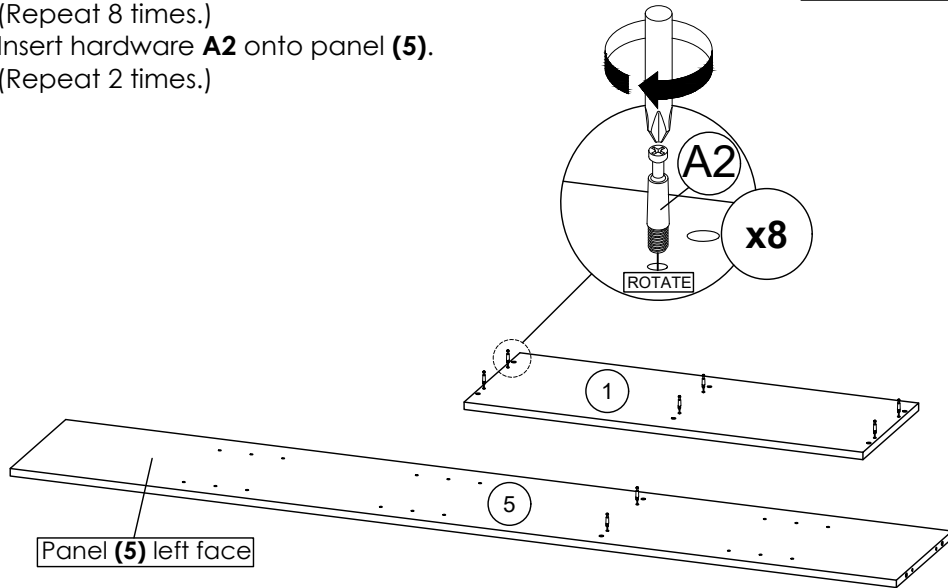

STEP 2

- Insert hardware **A1** onto panel **(3)**, **(4)** and **(5)**.
(Repeat 6 times.)
- Insert hardware **A2** onto panel **(3)**, **(4)** and **(5)**.
(Repeat 6 times.)
- Insert hardware **B** onto panel **(3)**, **(4)** and **(5)**.
(Repeat 12 times.)

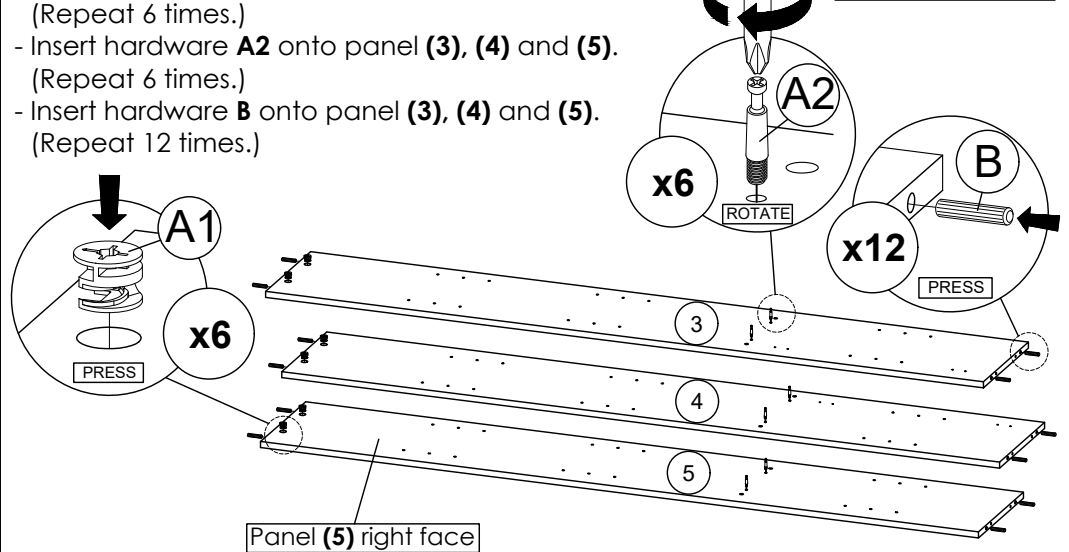

* Ensure the arrows on hardware **A1** point towards mounting positions.

STEP 3

- Insert hardware **A1** onto panel **(6)**.
(Repeat 8 times.)
- Insert hardware **B** onto panel **(6)**.
(Repeat 8 times.)

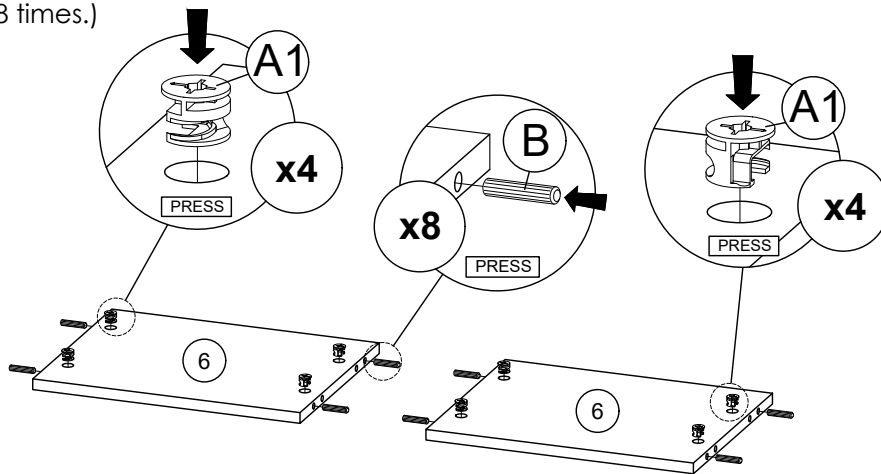

* Ensure the arrows on hardware **A1** point towards mounting positions.

STEP 4

- Attach panel **(6)** to panel **(3)**, **(4)** and **(5)**.
- Insert all hardware **A2** into **A1**.
- Rotate all **A1** until tight.
- Apply **A3** onto all **A1**.
(Repeat 8 times.)



OR

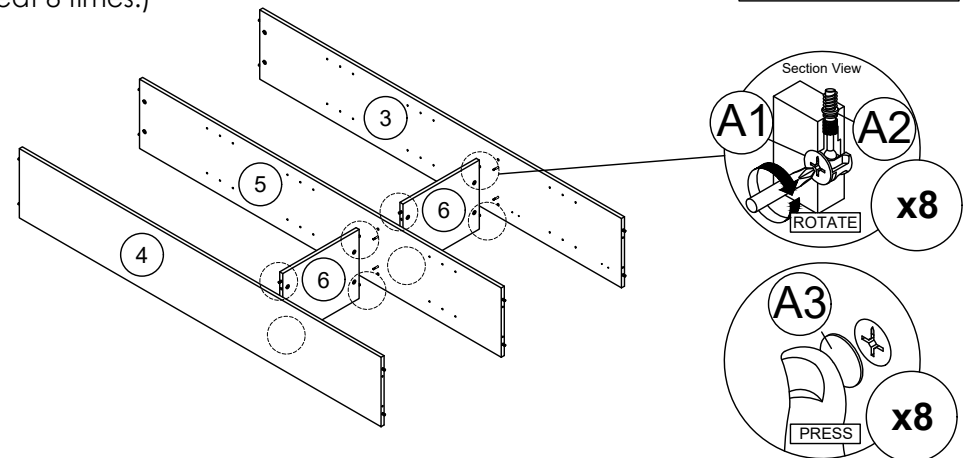

* In this step hardware **A1**, **A2** and **B** are pre-inserted.

ASSEMBLY INSTRUCTIONS

PAGE: 3/5

STEP 5

- Attach panel **(3)**, **(4)** and **(5)** to panel **(1)**.
 - Insert all hardware **A2** into **A1**.
 - Rotate all **A1** until tight.
 - Apply **A3** onto all **A1**.
- (Repeat 6 times.)

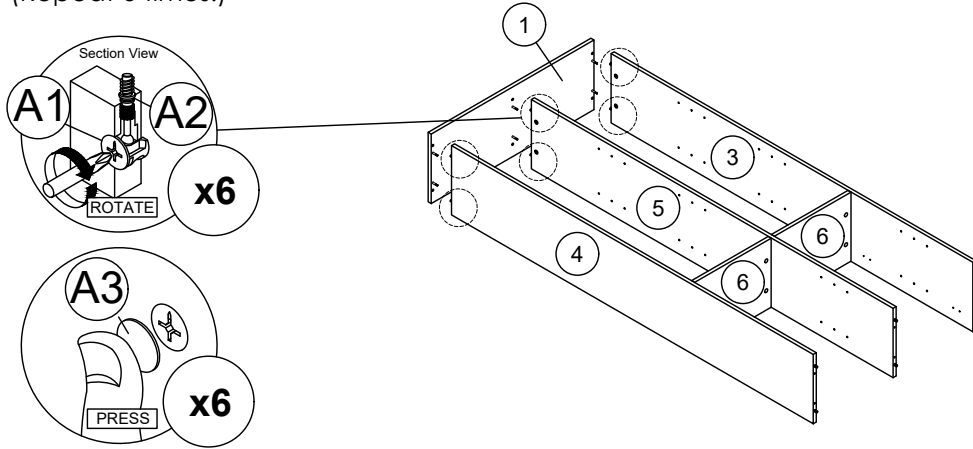
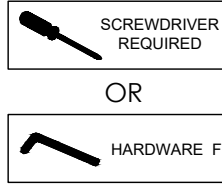

* In this step hardware **A1**, **A2** and **B** are pre-inserted.

STEP 7

- Assemble part **11** and **12** into panel **(2)** by using hardware **F**, **K**, **L** and **M**.
(Repeat 8 times.)

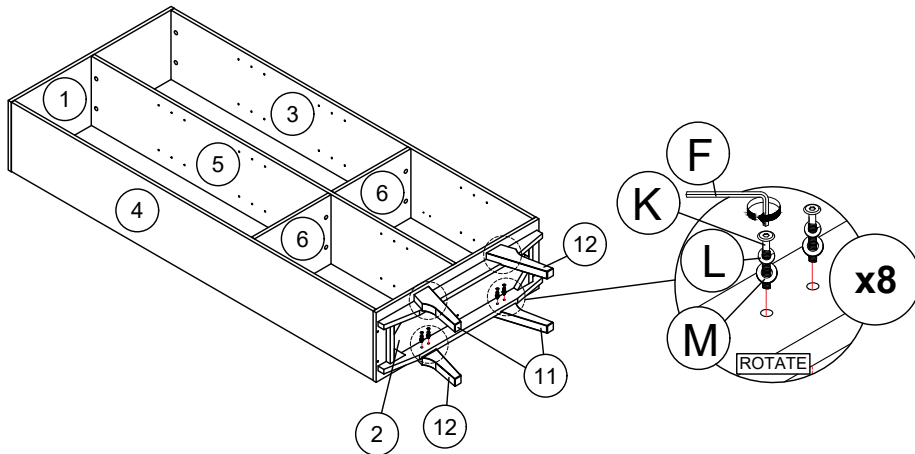

STEP 6

- Connect panel **(2)** to panel **(3)**, **(4)** and **(5)** by using hardware **C** and **F**.
(Repeat 6 times.)

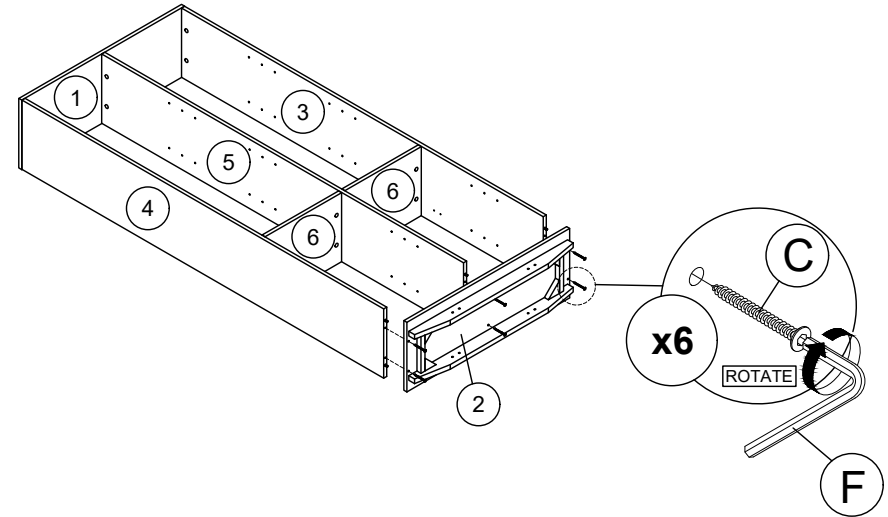

* In this step hardware **B** are pre-inserted.

STEP 8

- Assemble panel **(8)** to entire body with hardware **G**.
(Repeat 40 times.)

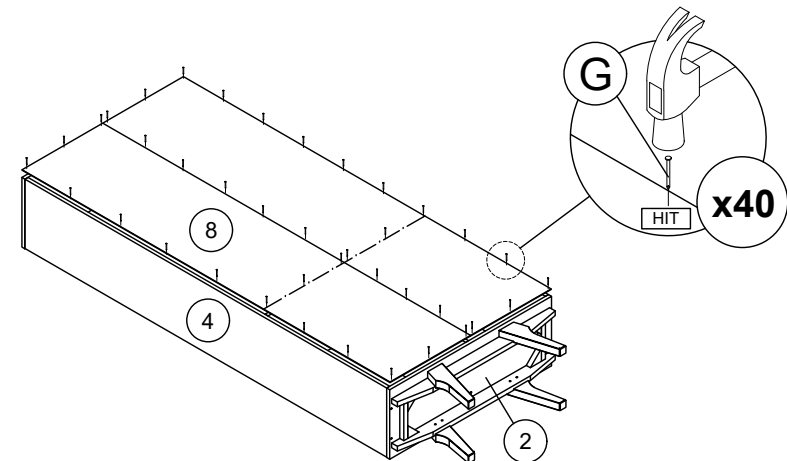

ASSEMBLY INSTRUCTIONS

PAGE: 4/5

STEP 9

Insert hardware **I** into mounting positions on panel **(3)**, **(4)** and **(5)** by hand.
(Repeat 24 times.)

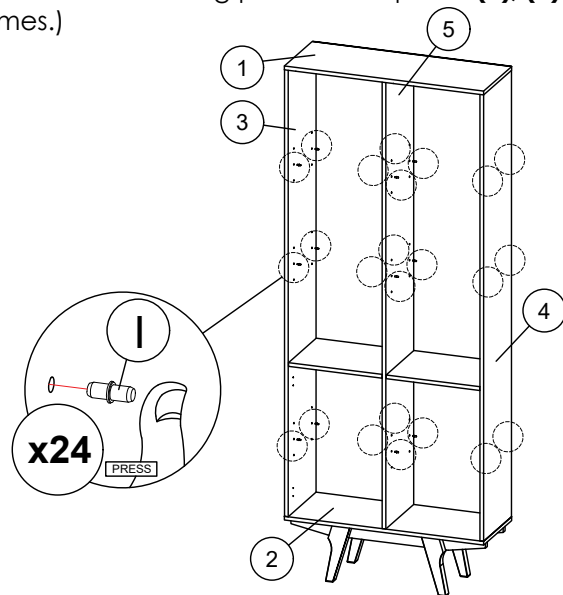

STEP 10

- Assemble the panel **(7)** into between panel **(3)** and **(5)**.
(Repeat 3 times.)
- Assemble the panel **(7)** into between panel **(4)** and **(5)**.
(Repeat 3 times.)

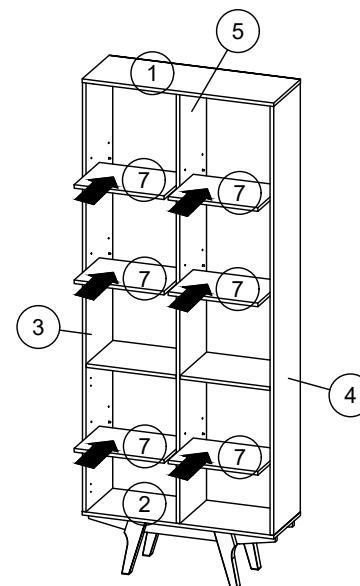

* In this step hardware **I** are pre-inserted.

STEP 11

- Fix hardware **H** onto panel **(9)** and **(10)** by using hardware **D**.
(Repeat 8 times.)
- Fix hardware **J** onto two panel **(9)** and **(10)** by using hardware **E**.
(Repeat 4 times.)

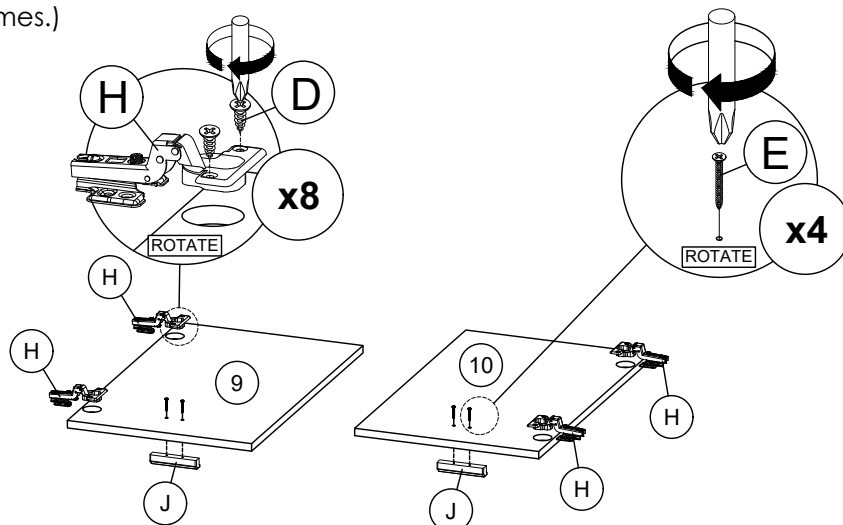

STEP 12

- Fix hardware **H** into panel **(3)** and **(4)** by using hardware **D**.
(Repeat 4 times.)
- Tighten or loosen the screw to adjust position of panel **(9)** and **(10)**.
(Do only when needed.)

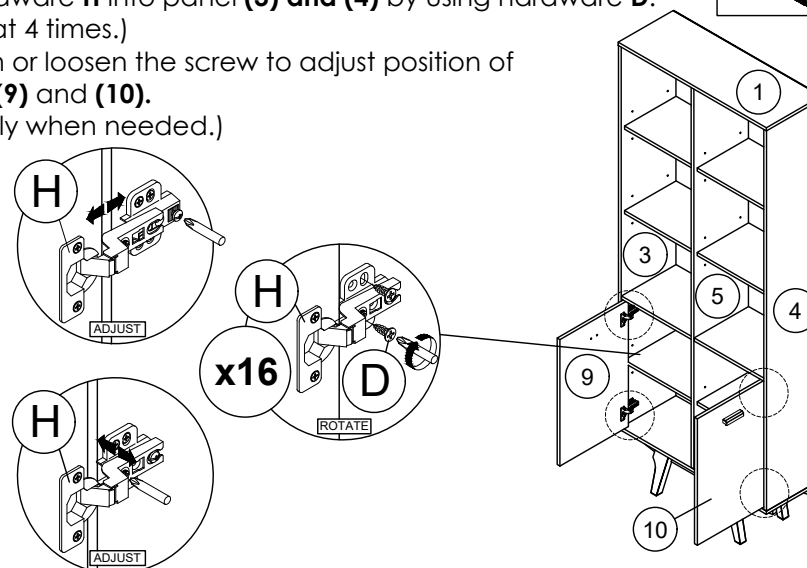
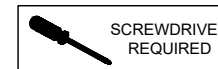

* In this step hardware **H** have been assembled in panel **(9)** and **(10)**.

ASSEMBLY INSTRUCTIONS

PAGE: 5/5

STEP 13

Assemble hardware **N1** into panel **(1)** and **(8)** by using hardware **N2**.
(Repeat 2 times.)

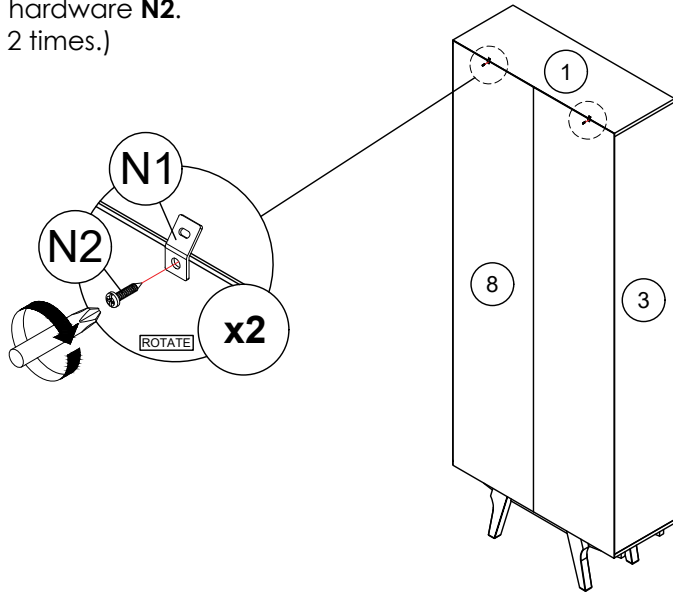

STEP 14

- Mark and use the power drill to drill a hole on the wall.
- Hit hardware **N3** into the wall.
(Repeat 2 times.)

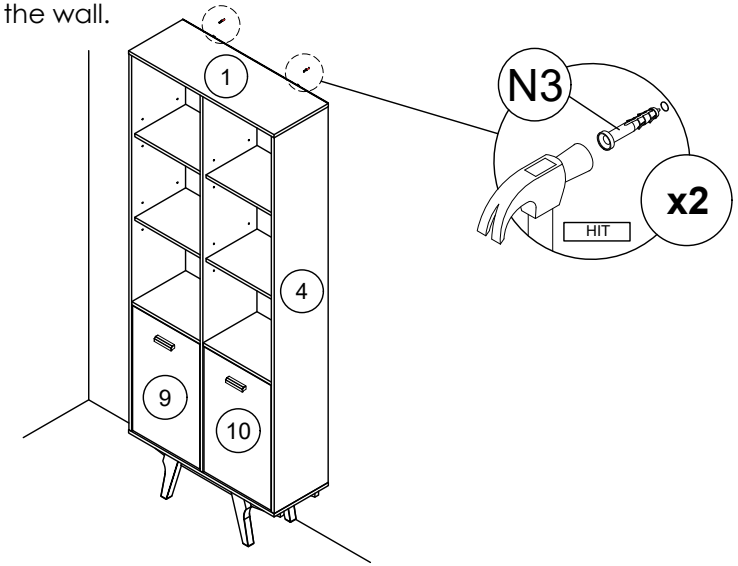

STEP 15

- Assemble hardware **N1** to **N3** by using hardware **N4**.
(Repeat 2 times.)

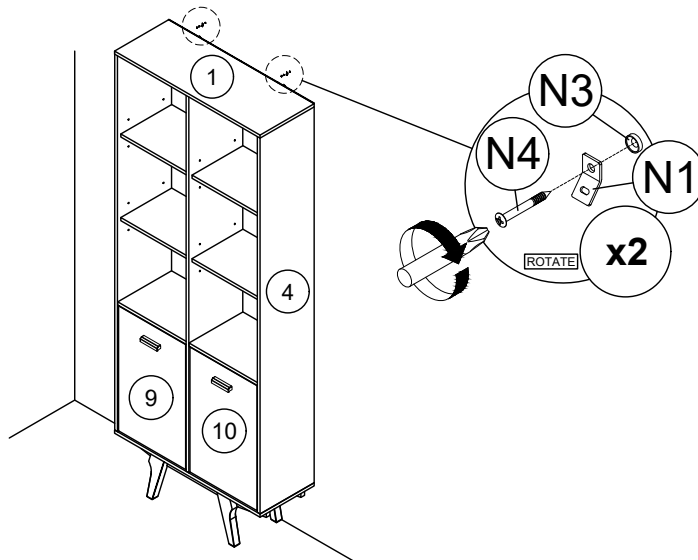

STEP 16

- Connect two of the hardware **N1** by using hardware **N5**.
- Tighten the hardware **N5**.
(Repeat 2 times.)

