

# ASSEMBLY INSTRUCTIONS

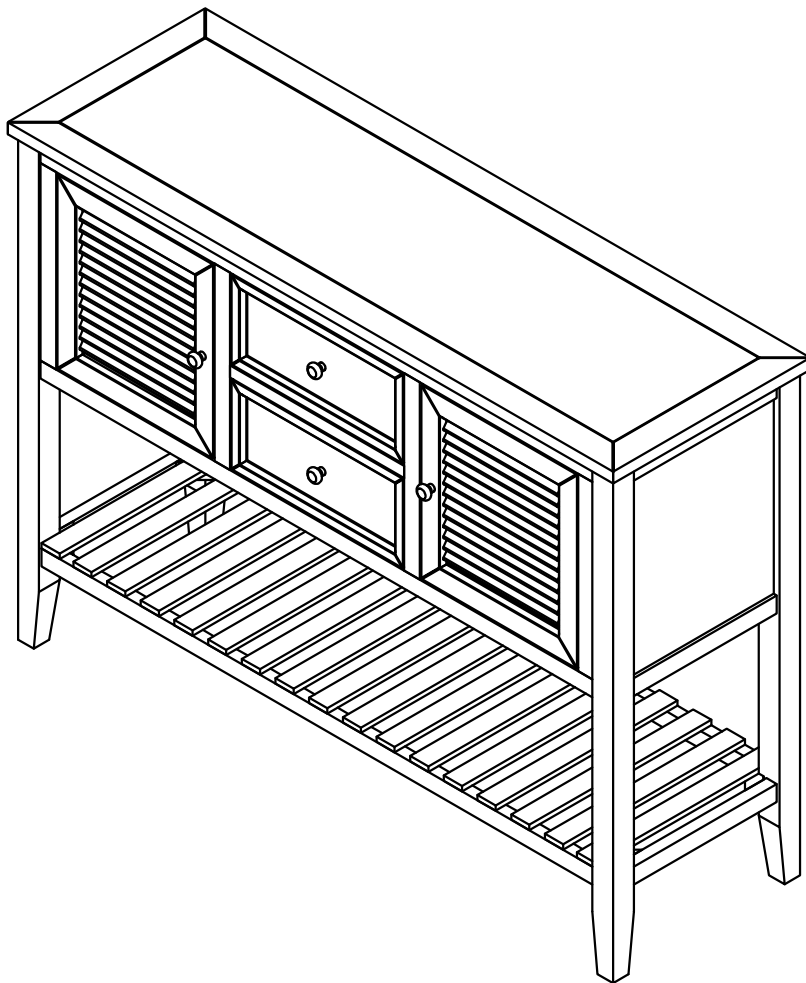





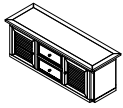

WF196438 - SIDE TABLE

## IMPORTANT NOTE :

- \*\* PLACE ALL PARTS ON A CLEAN AND SMOOTH SURFACE SUCH AS A RUG OR CARPET TO AVOID THE PARTS FROM BEING SCRATCHED.
- \*\* BEFORE YOU BEGIN, KINDLY FOLLOW THE ASSEMBLY INSTRUCTIONS STEP BY STEP.
- \*\*DO NOT TIGHTEN ALL SCREWS AND BOLTS UNTIL THE TABLE IS FULLY SET-UP.

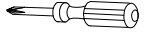

CARTONS ONLY ONE/ CARTONS SEULEMENT UN

PART LISTS				HARDWARE LISTS			
NO.	DESCRIPTION	SKETCH	Q'TY	NO.	DESCRIPTION	SKETCH	Q'TY
1	TABLE TOP		1 PC	A	BOLT Ø1/4" x 50mmL		12 PCS
2	LEGS		4 PCS	B	SPRING WASHER Ø1/4" x 13mmL		12 PCS
3	SHELF		1 PC	C	FLAT WASHER Ø1/4" x 19mmL		12 PCS
				D	ALLEN KEY		1 PC
				E	TIPPING		1 SETS
				 Not Included			

ASSEMBLY INSTRUCTIONS

STEP 1:

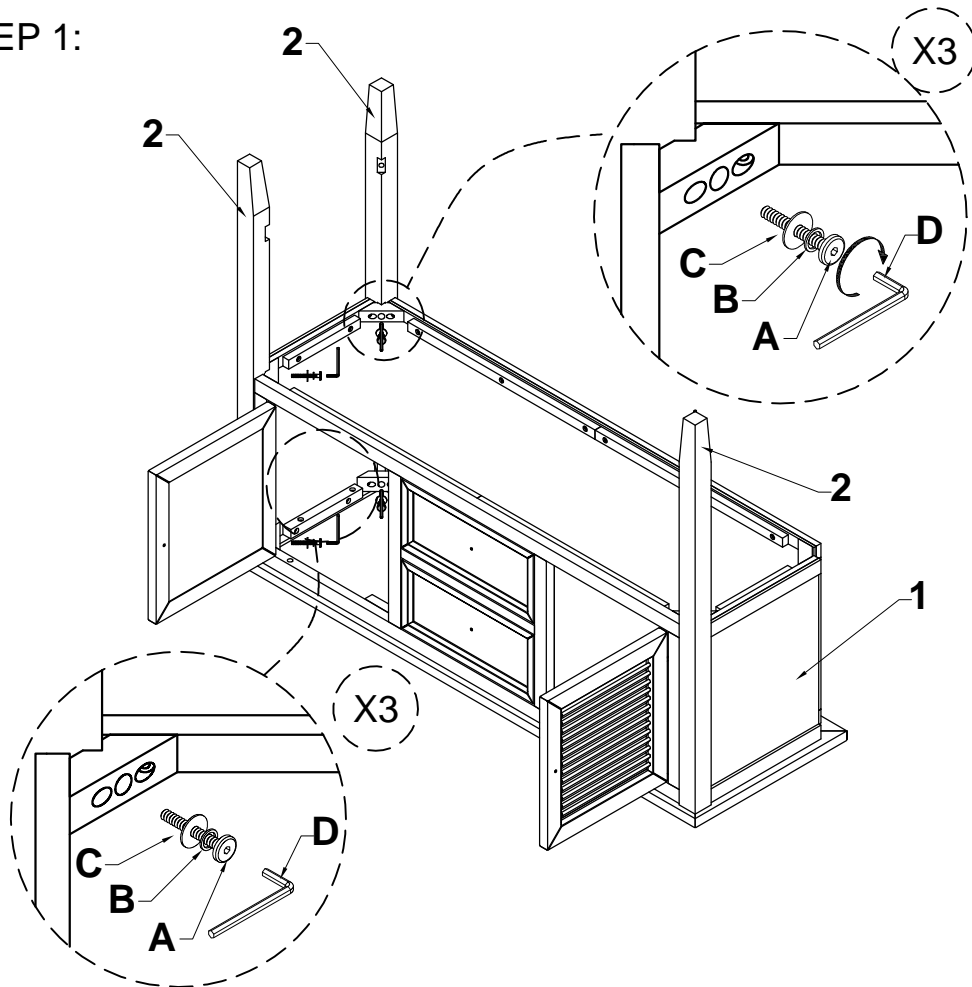

# ASSEMBLY INSTRUCTIONS

STEP 2:

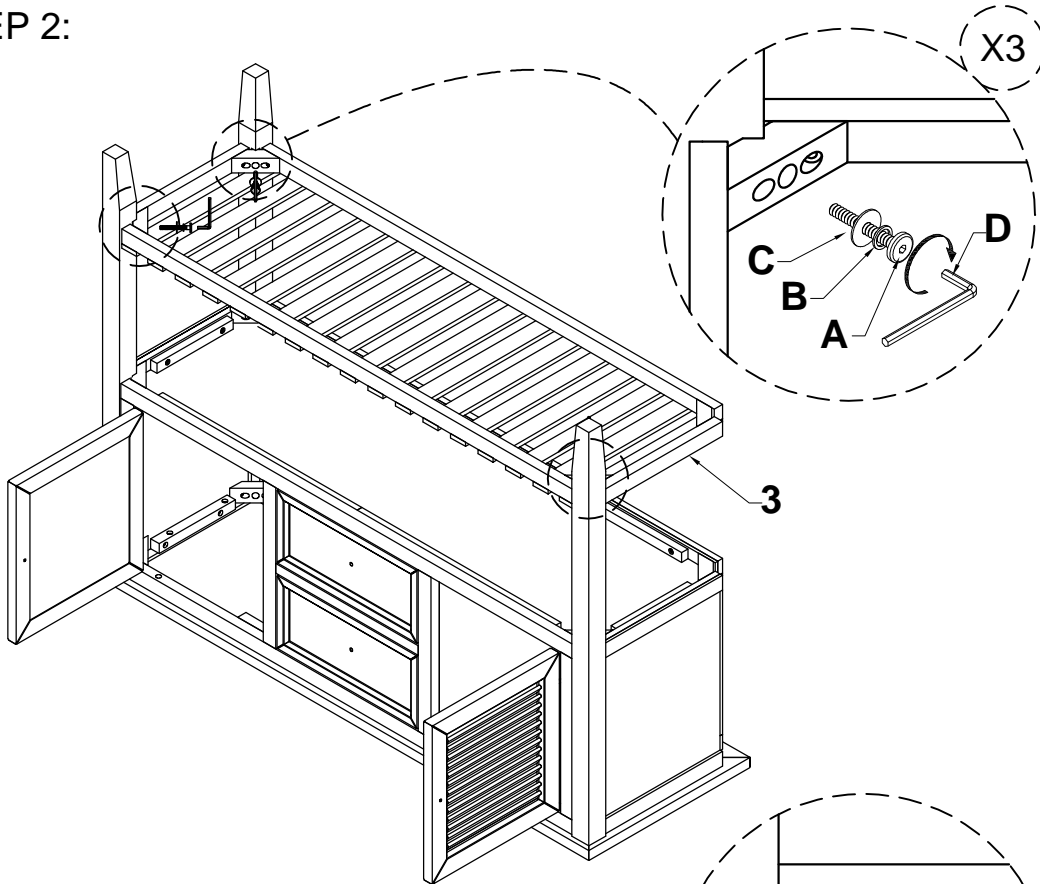

STEP 3:

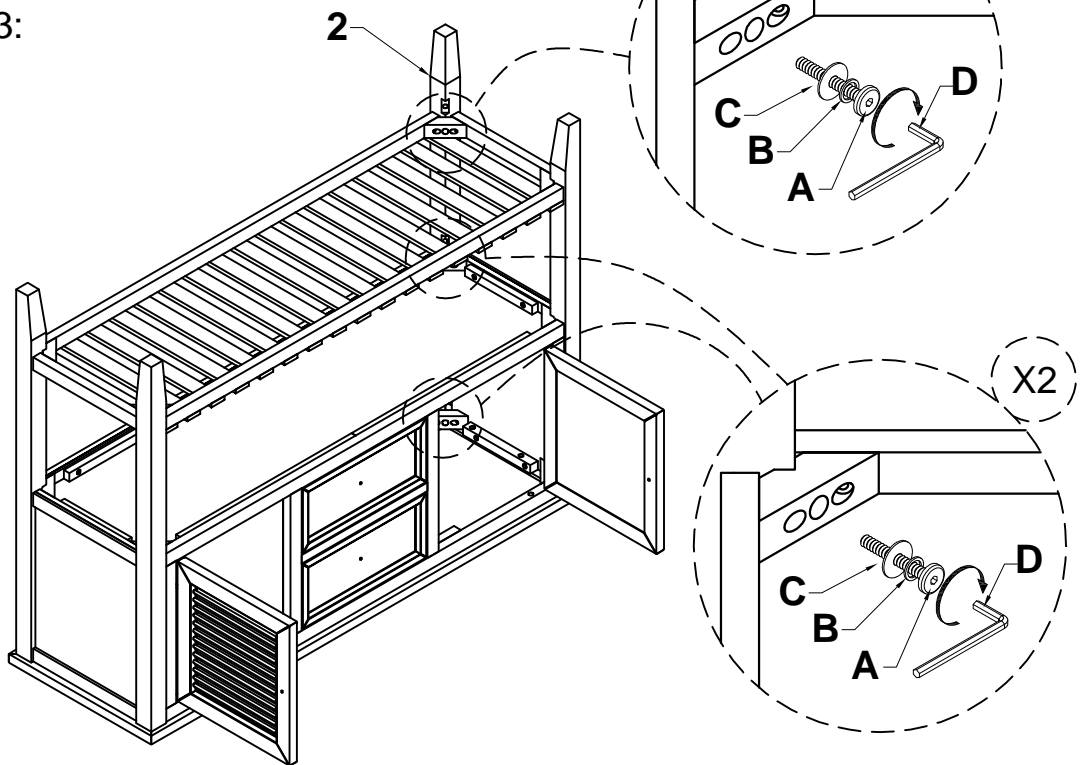

# ASSEMBLY INSTRUCTIONS

STEP 3:

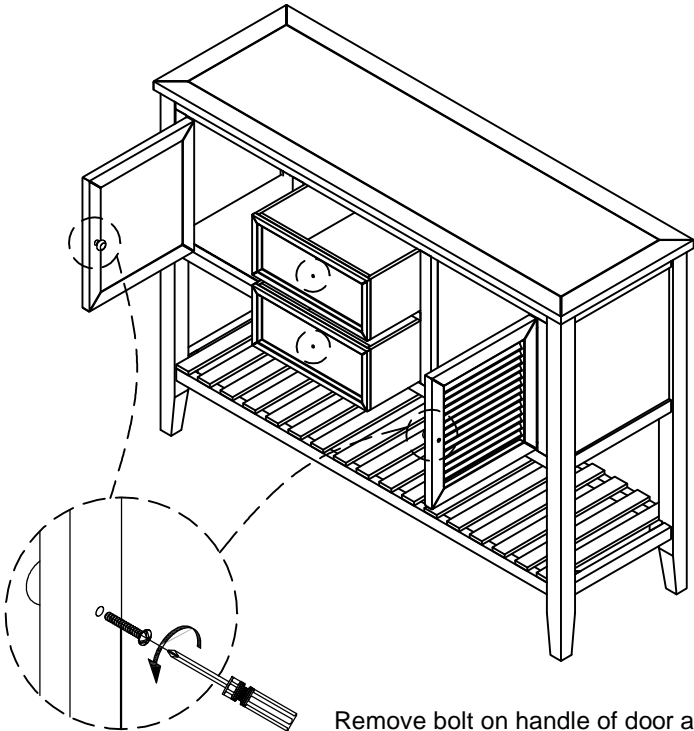

Remove bolt on handle of door and drawer front

STEP 4:

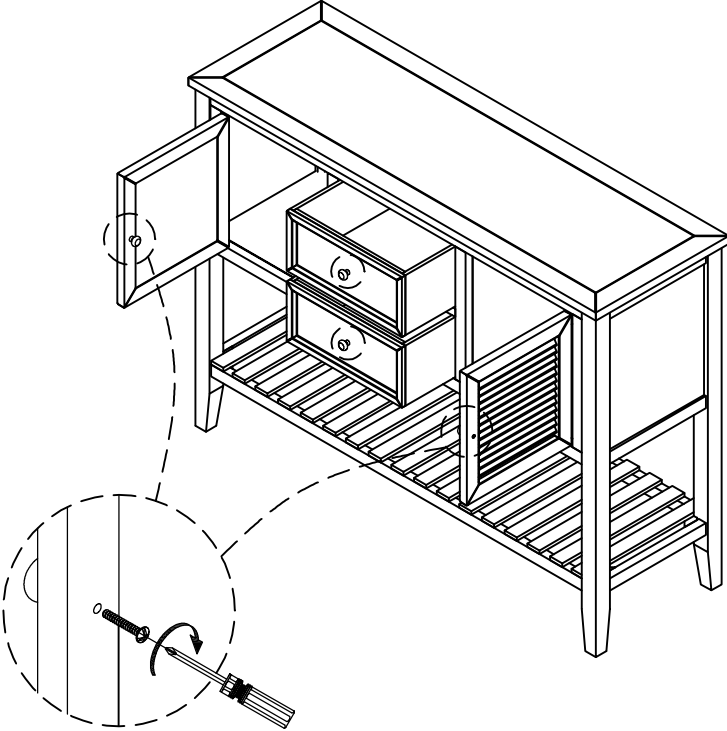

# ASSEMBLY INSTRUCTIONS

STEP 6:

